

Installation Guide and Support Manual

PHOENIX

Phase Converters

GP30PL





GENERAL SPECIFICATIONS	
HP	30
KW	21.4
KVA	26.02
HZ	50/60
ENCL	TEFC/NEMA 4
FRAME	268T
IDLER WEIGHT	396.9
PANEL WEIGHT	45

CONSTRUCTION, DIMENSIONS, WEIGHT	
ELECTRICAL PANEL	
ENCLOSURE TYPE	NEMA 4
ENCLOSURE CERTIFICATIONS	UL 508A (CSA C22.2 No. 14-13.), TUV, CE.
COLOR	Light Gray
HEIGHT	20
WIDTH	12
DEPT	10
MOUNTING	WALL MOUNT

SINGLE PHASE ELECTRICAL SPECS	
VOLTAGE INPUT	208-250V
MOTOR LOAD BREAKER Minimum Size	50
MOTOR LOAD BREAKER Maximum Size	150
SERVICE KVA Minimum Size	50
SERVICE AMPS Minimum Size	200
COPPER WIRE Minimum Size	2

THREE PHASE ELECTRICAL SPECS	
VOLTAGE OUTPUT	208-230 Volts Delta
MAX OUTPUT INDUCTIVE LOAD AMPS	80
MAX OUTPUT RESISTIVE LOAD AMPS	42
VOLTAGE BALANCING	+/- 2%
WIRE SIZE MIN Idler/Generator	3
LARGEST SPINDLE MOTOR START	15
LARGEST COMPRESSOR LOAD START	12
TOTAL COMBINED HORSEPOWER RUN	30

Optional Feature

- 208, 460 Volt Output (includes transformer)
- AutoStart and AutoOff with load detection
- PL Model (includes Start and Stop with Built-in Mag Starter)
- GPX Model (includes WFI Cloud Controls, Timers, Energy Monitor)
- Wireless Remote ON/OFF

PHOENIX PHASE CONVERTERS

800-417-6568

CAUTION

READ INSTRUCTIONS BEFORE OPERATING

READ FIRST - BEFORE INSTALLATION

- **Most important step to know.**
- NEVER Start the phase converter with a load, this includes transformers.
- Make sure you have the incoming service to start the phase converter, call your electric company verify the KVA size of the transformer, that KVA number should be larger then the HP of the idler motor.
- **DO NOT use WIRE NUTS for any connection, use the bolt down lugs. Check all make sure all connections even factory connections to the power block are secure, also recheck connections after a few week of using the converter.**
- **When powering up the unit, if the idler does NOT come up to FULL SPEED, then shut the phase converter down right away. If you don't understand then call us or a qualified electrician. if you do not turn the unit off you have a chance to damage the idler motor that will not be covered under warranty.**
- Must be installed by a license industrial electrician, our guidelines are not to supersede local and state laws.

Power requirements

- You will need to use a **motor load** type breaker. NOT a quick blow or trip breaker.
- Sizing a breaker for a single machine with an inductive load (motors) double the amps size of the machine. Example if the equipment pulls 20 amps use a 40 amp breaker.
- Sizing the equipment for multiple machine double the amp of the largest machine and add the the other machine that will run at the same time. Example; 20 AMP Lathe. 9 amp saw, 6 amp milling machine. $20 \times 2 = 40 + 9 + 6 = 45$ amps, use the next standard size breaker which would be 50 Amps two pole breaker.
- Use the chart to make sure you don't go over or under the Minimum and maximum size allowed. For rural areas increase the minimum size breaker by 20% Click on the next picture to see this chart.

GP30

WIRE AND BREAKER SIZES	
SINGLE PHASE	2 AWG Copper under 50 feet
IDLER MOTOR	3 AWG COPPER
BREAKER/FUSE	50 MIN / 150 MAX

Mounting the Phase Converter Panel

Mount the enclosure first, to a non-vibrating surface, there are two options provided for mounting, next install the back plate with the four nuts provided. Mounting the phase converter panel near the breaker panel is recommended the larger wire is you single phase line, that is best to keep as short as possible. Every 50 feet you will need to increase the size of the single phase wire.



Additional mounting brackets and hardware are inside the enclosure.



Indoor or outdoor enclosure



CONNECTING THE IDLER MOTOR WIRES

THIS IS JUST A ILLUSTRATION OF WHAT WIRES GET CONNECTED TOGETHER, **DO NOT USE WIRE NUTS**, USE BOLT DOWN LUGS

IF YOU HAVE 9 LEADS AT THE MOTOR CLICK HERE

IF YOU HAVE 12 LEADS AT THE MOTOR CLICK HERE

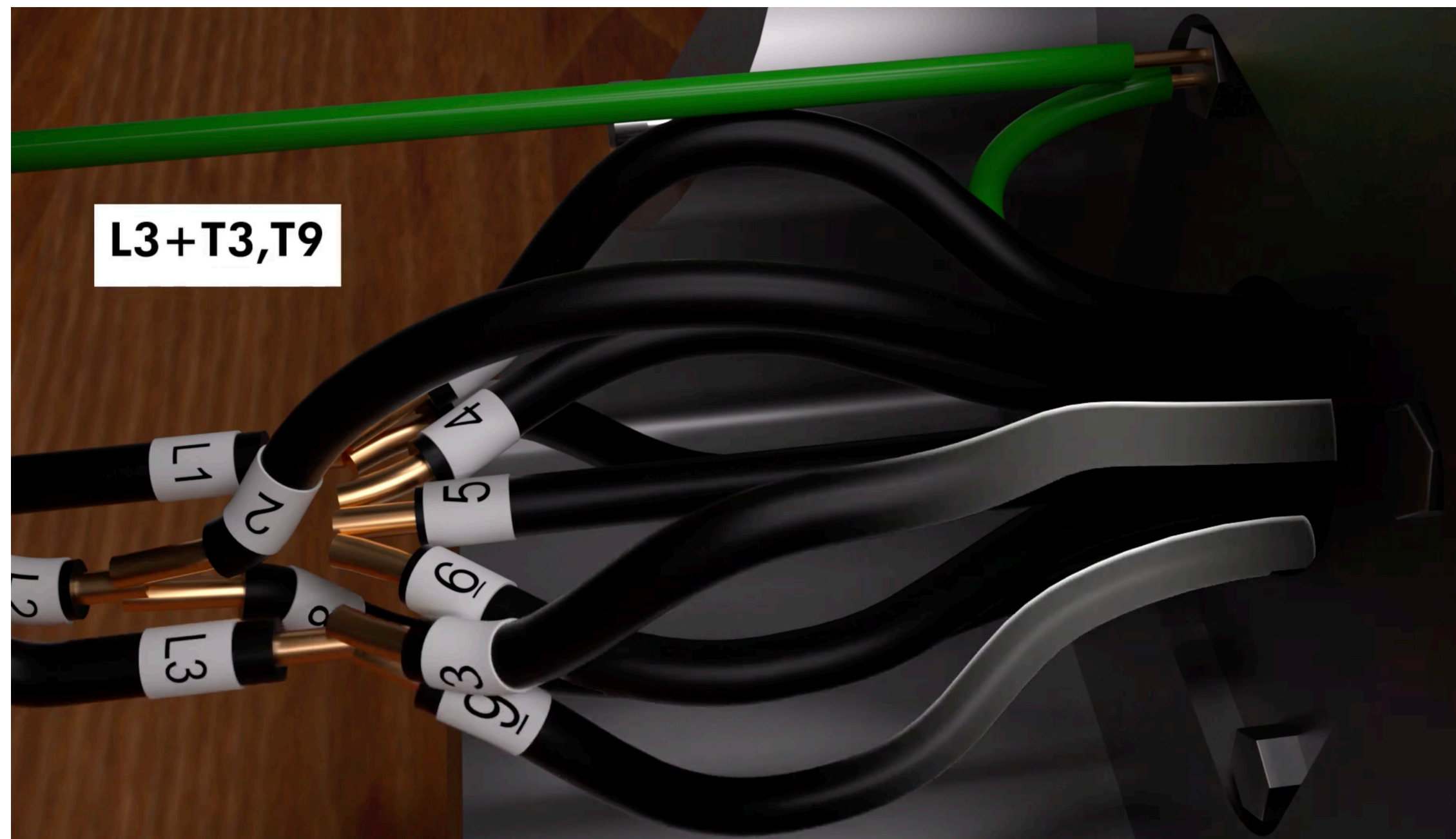

PL AND PH MODELS

MUST BE INSTALLED BY A INDUSTRIAL LICENSED ELECTRICIAN

Motor Load Breaker should be size
Twice the full load amps of your
equipment

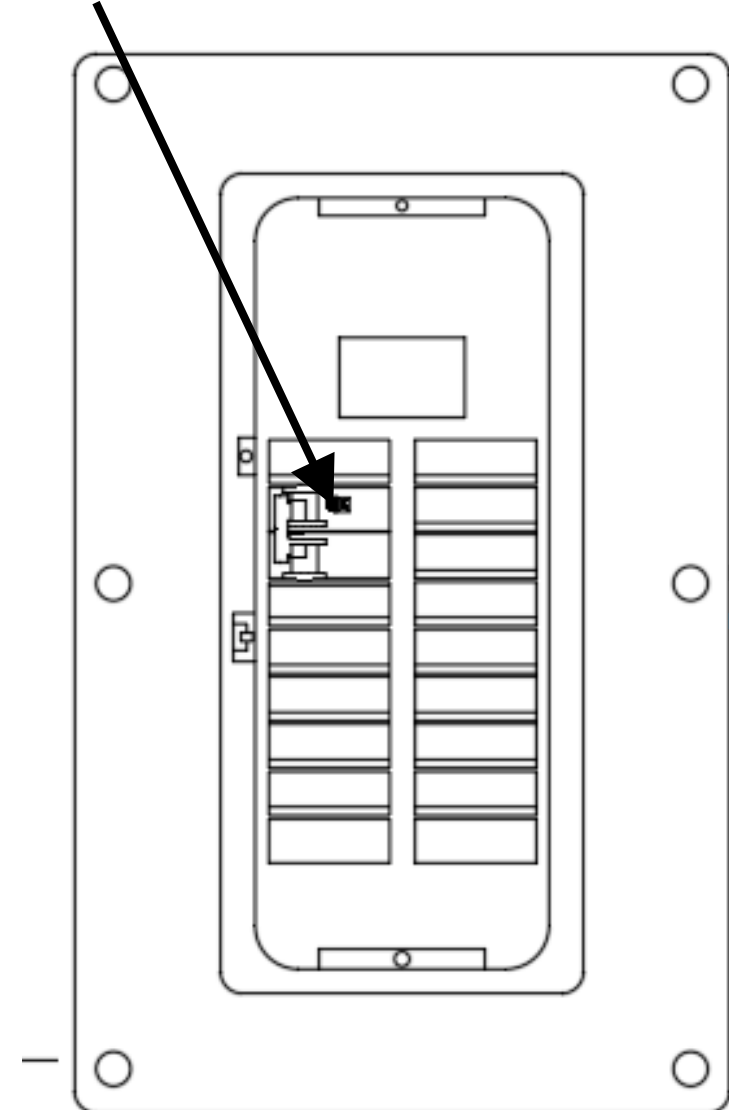

SINGLE PHASE CIRCUIT
BREAKER PANEL

2 AWG Copper
Under 50 Feet

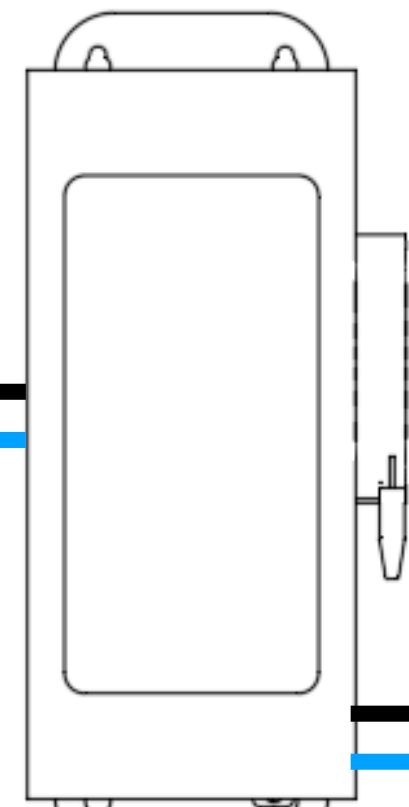

DISCONNECT
SHOULD BE USED
IF YOUR RUN IS
OVER 50 FEET

2 AWG Copper
Under 50 Feet

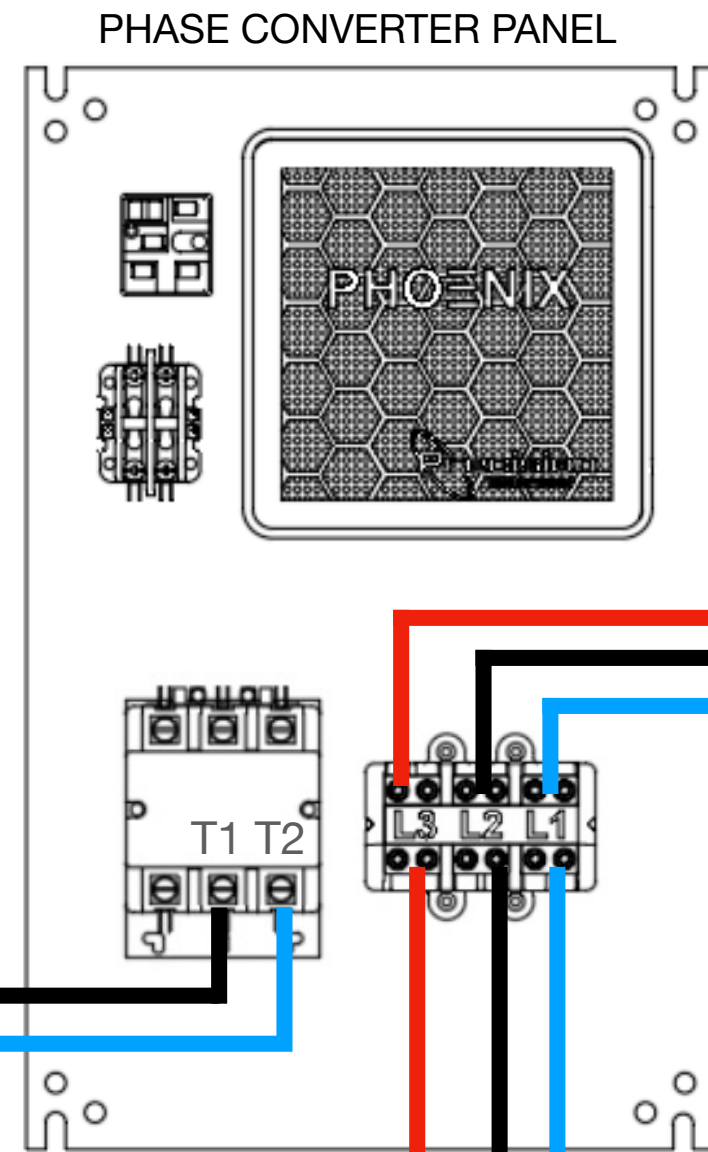

PHASE CONVERTER PANEL

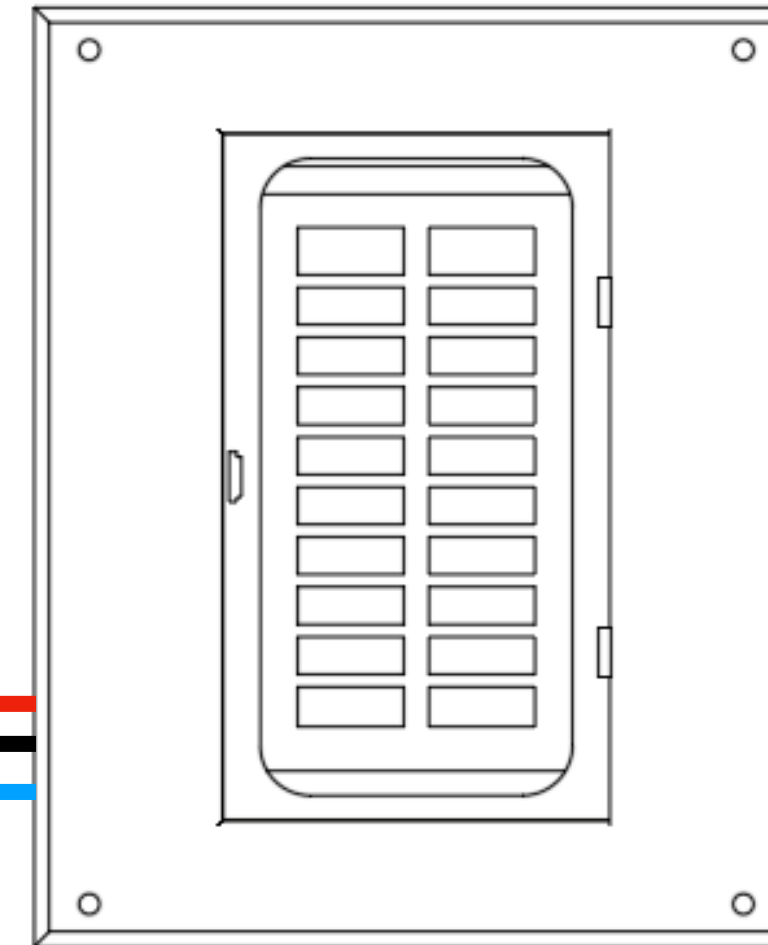

LOAD CENTER,
3PH BREAKER
PANEL, OR
EQUIPMENT

3 AWG Copper
Under 50 Feet

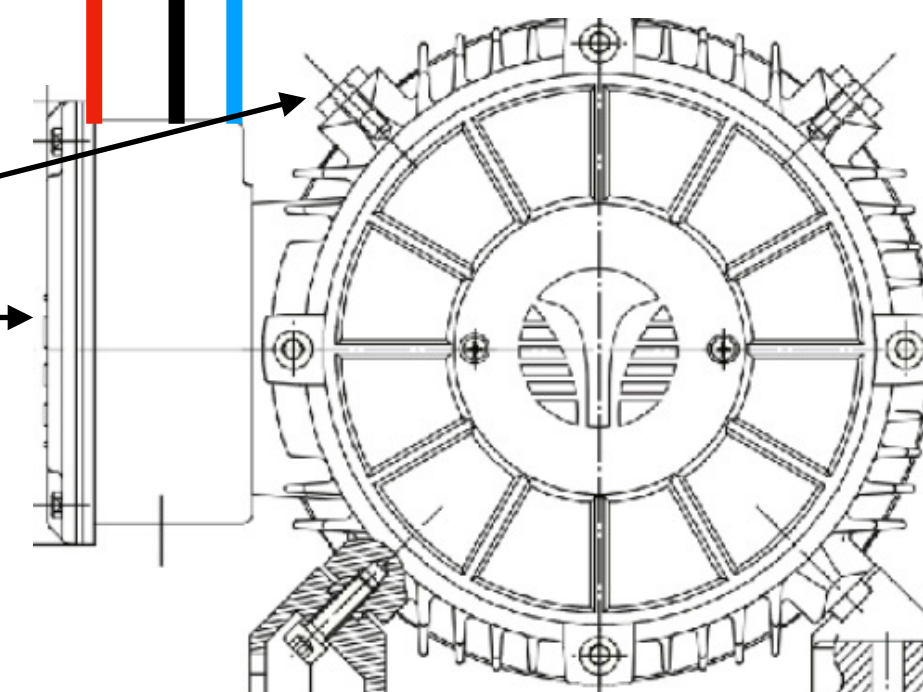

IDLER/GENERATOR
MOTOR

Connection Diagram Located
on the Name Plate or Inside the
Cover of the Connection Box

230V Connection for NL and PL Models (low voltage)

460V Connection for NH and PH Models (high voltage)

[IF YOU HAVE 12 LEADS AT THE MOTOR CLICK HERE](#)

[IF YOU HAVE 9 LEADS AT THE MOTOR CLICK HERE](#)

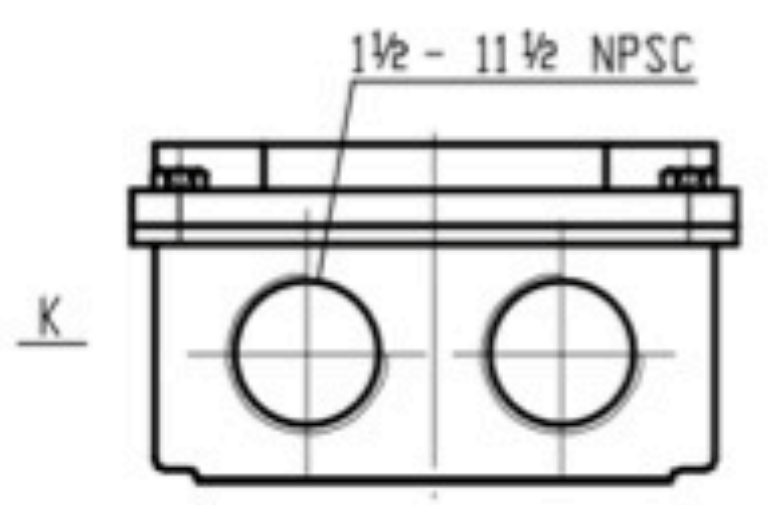
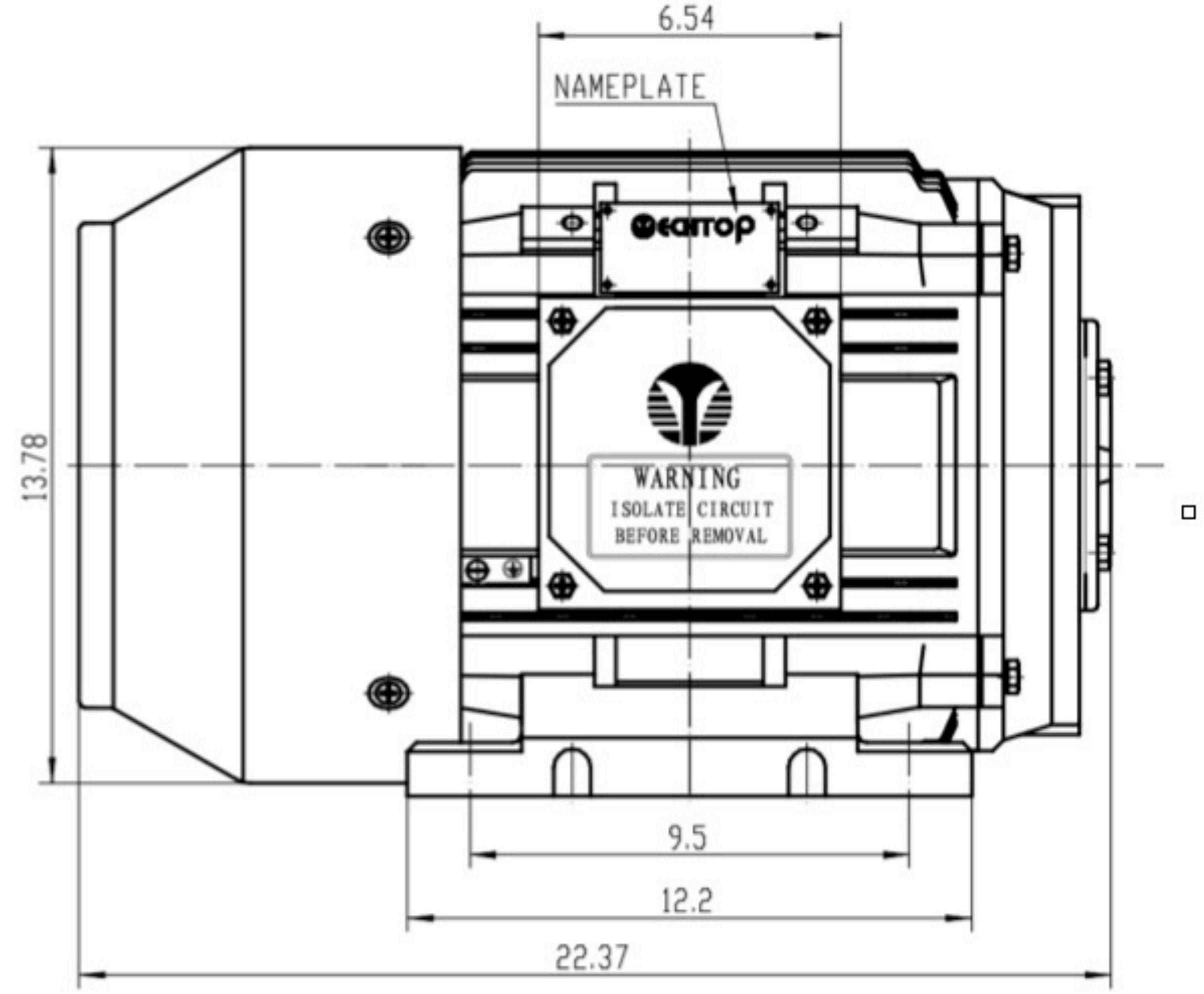
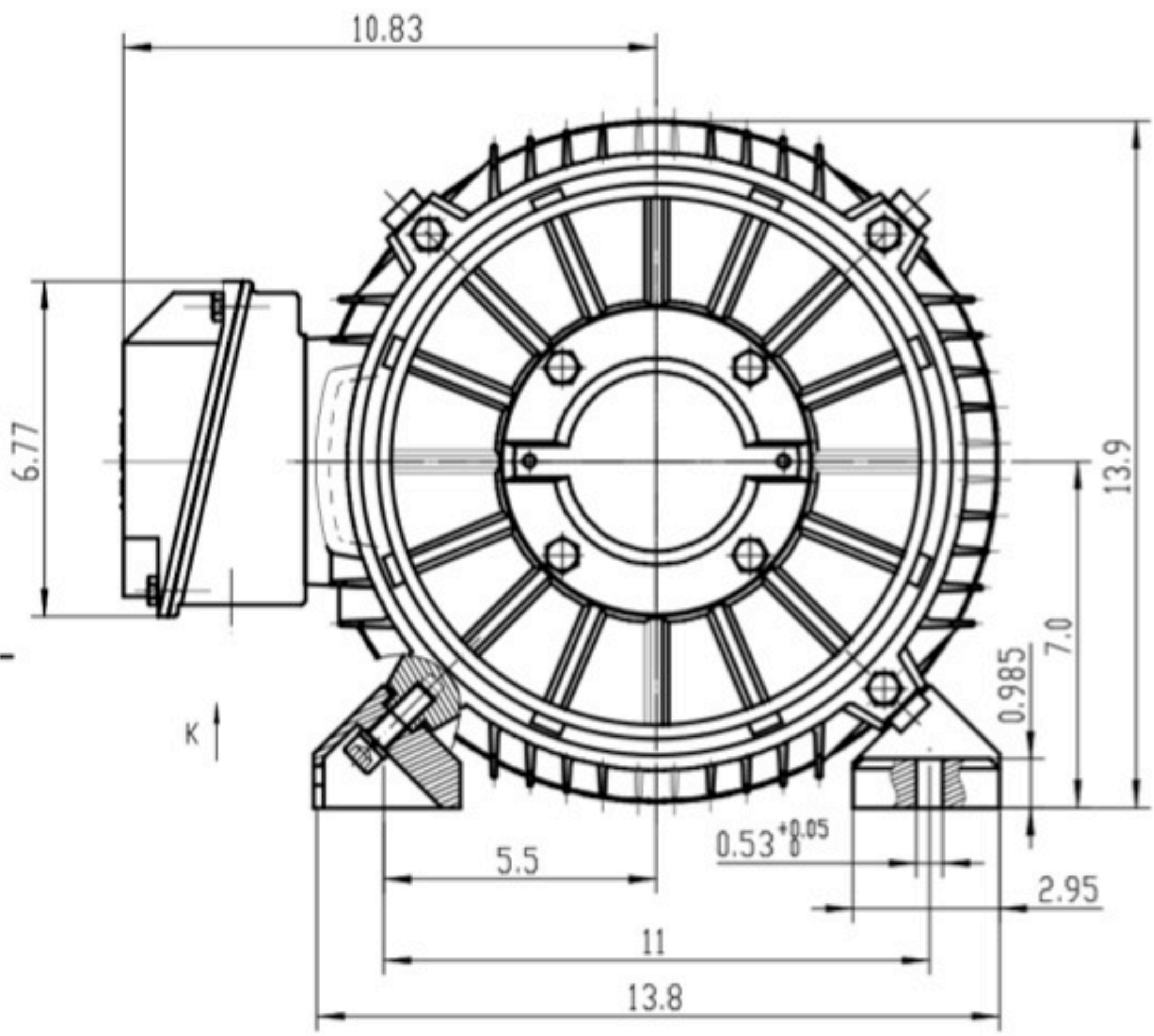

Weight: 30 HP = 396.9 lbs

GP30NL Dimensions

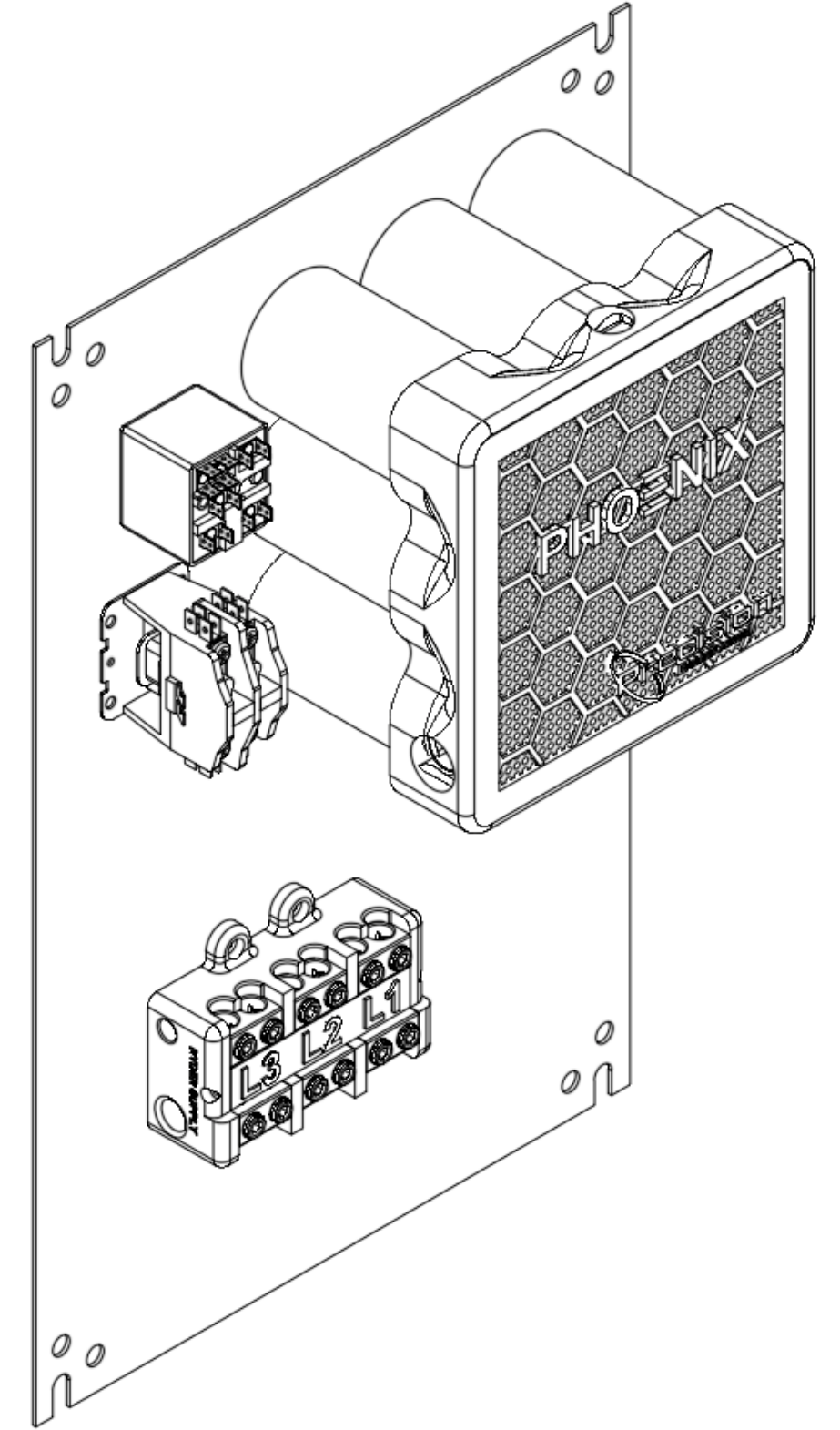
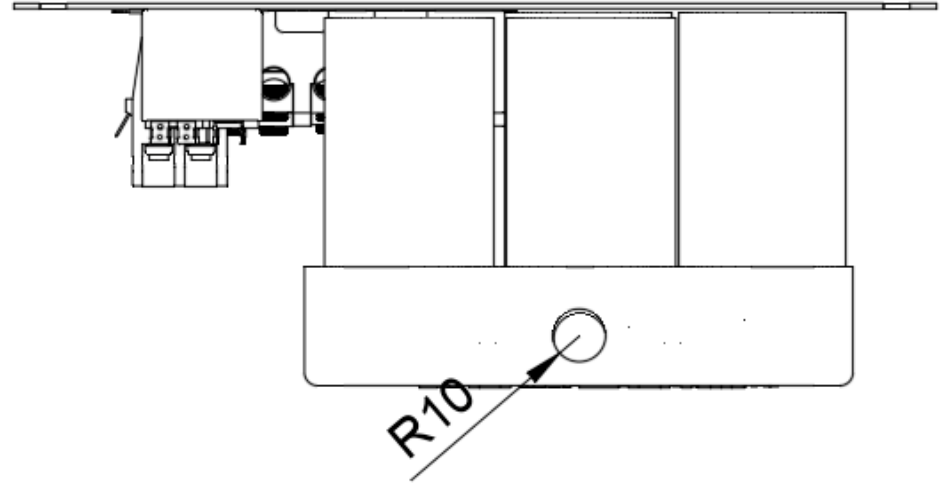
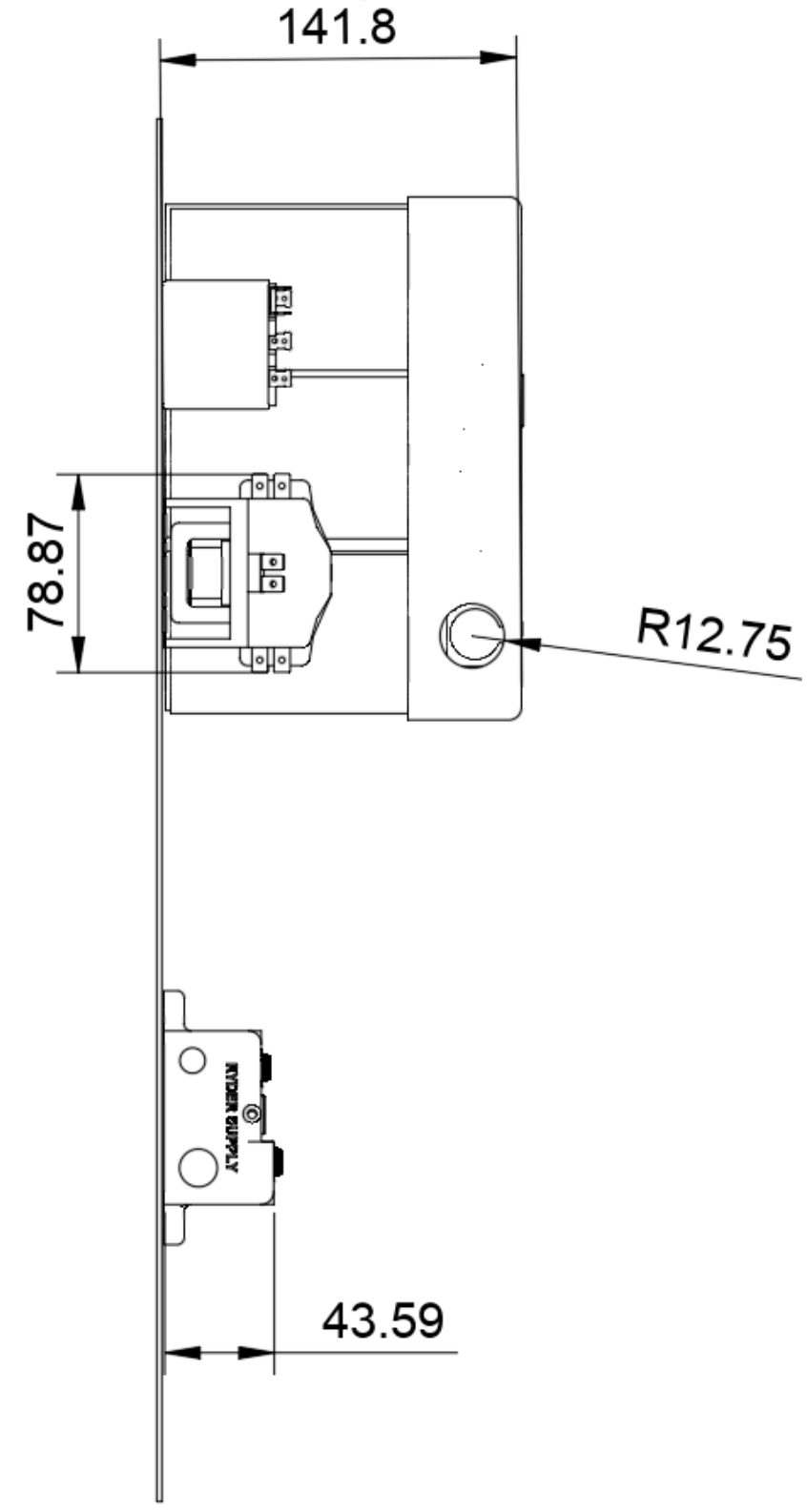
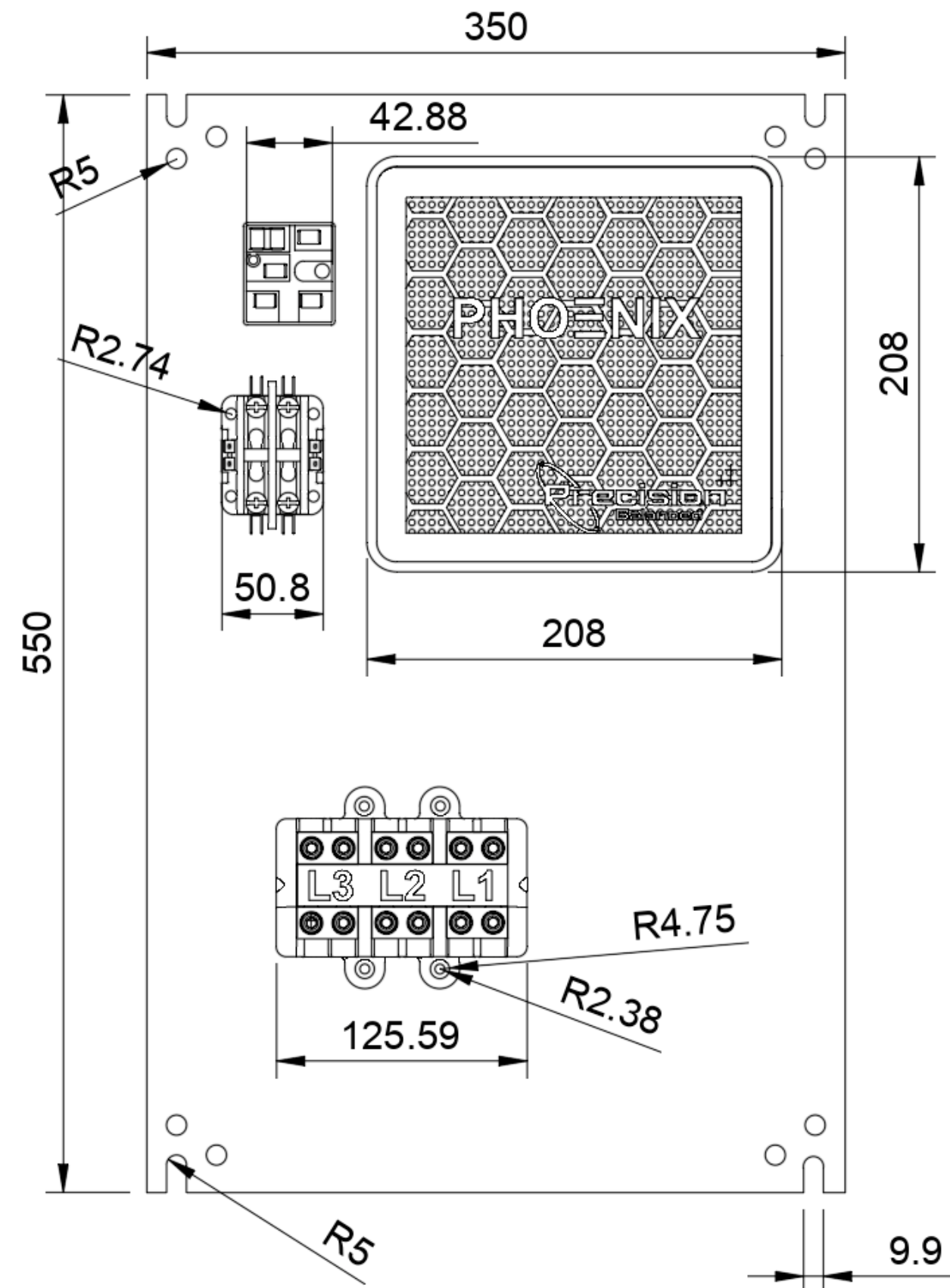
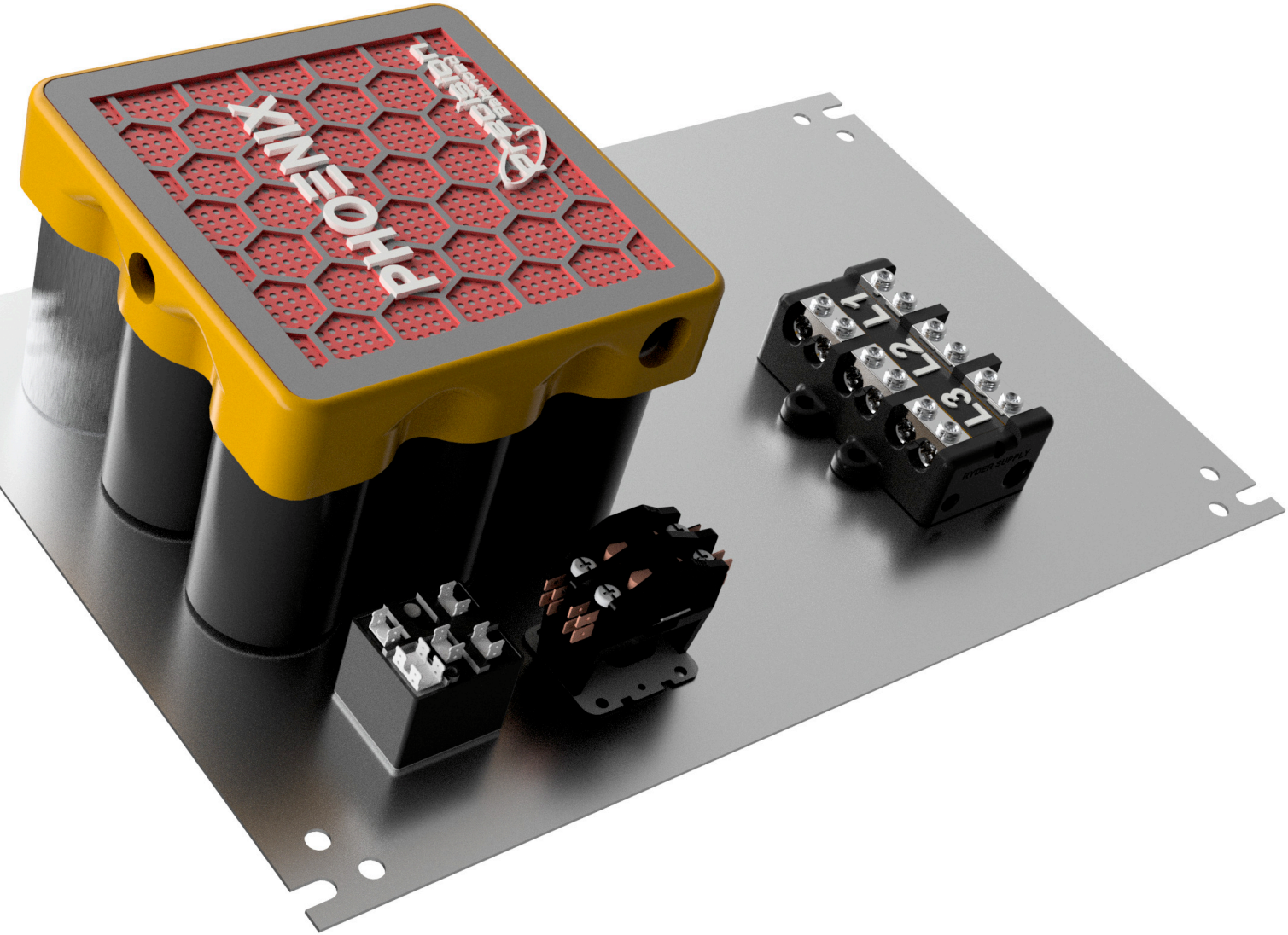

30 HP Rotary Phase Converter Components

Item Number	Description (Click on the description to visit the link to that item)	Quantity in Model	Price	SKU# (Click on 3D viewing)
1	Relay	1	47.00	GP90-66
3	2 Pole Contactor	1	28.00	GP2P30A
4	3 Pole Contactor 60 amp - 230V	1	52.84	C360C
5	9 Bank Start and Run Capacitor Holder Only with Base	1	239.00	CB409HO
6	3 Phase Power Block	1	45.00	RS2540
7	630 MFD 220V Start Capacitor	3	24.14	PTMJ630
*	100 MFD 370V Run Capacitor	1	26.00	TRC100
*	Complete Capacitor Bank Assembly - Prewired	1	390.00	CP309
*	Complete Back Plate Assembly - Prewired PL Model. (with Start and Stop Button)	1	1574.50	CBA30PL
*	Complete Panel with NEMA 4 Enclosure - Prewired PL Model (with Start and Stop Button)	1	1748.50	GP30PLPO
*	Idler Motor	1	1764.00	
*	Complete Unit Phase Converter Panel (PL Model) and Idler/Generator Motor	1	4079.00	GP30PL

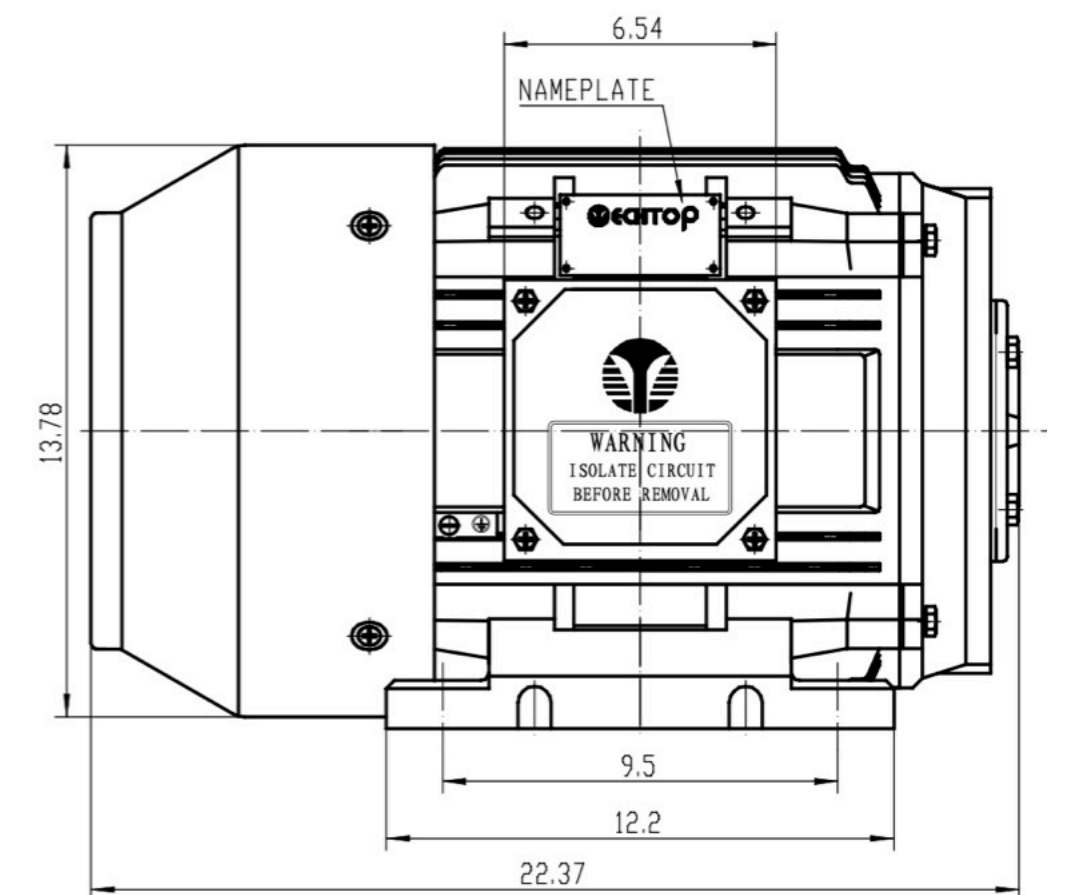
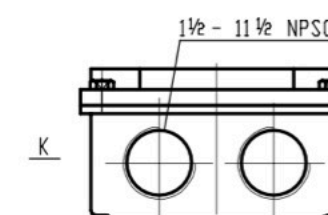
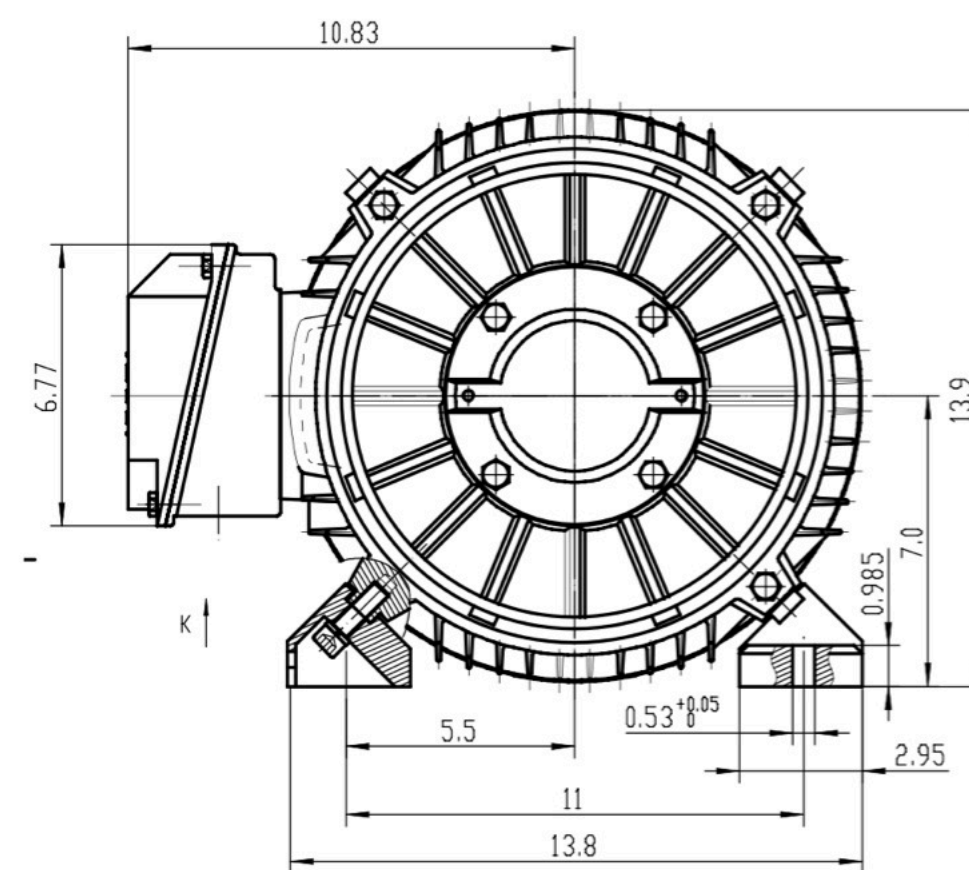
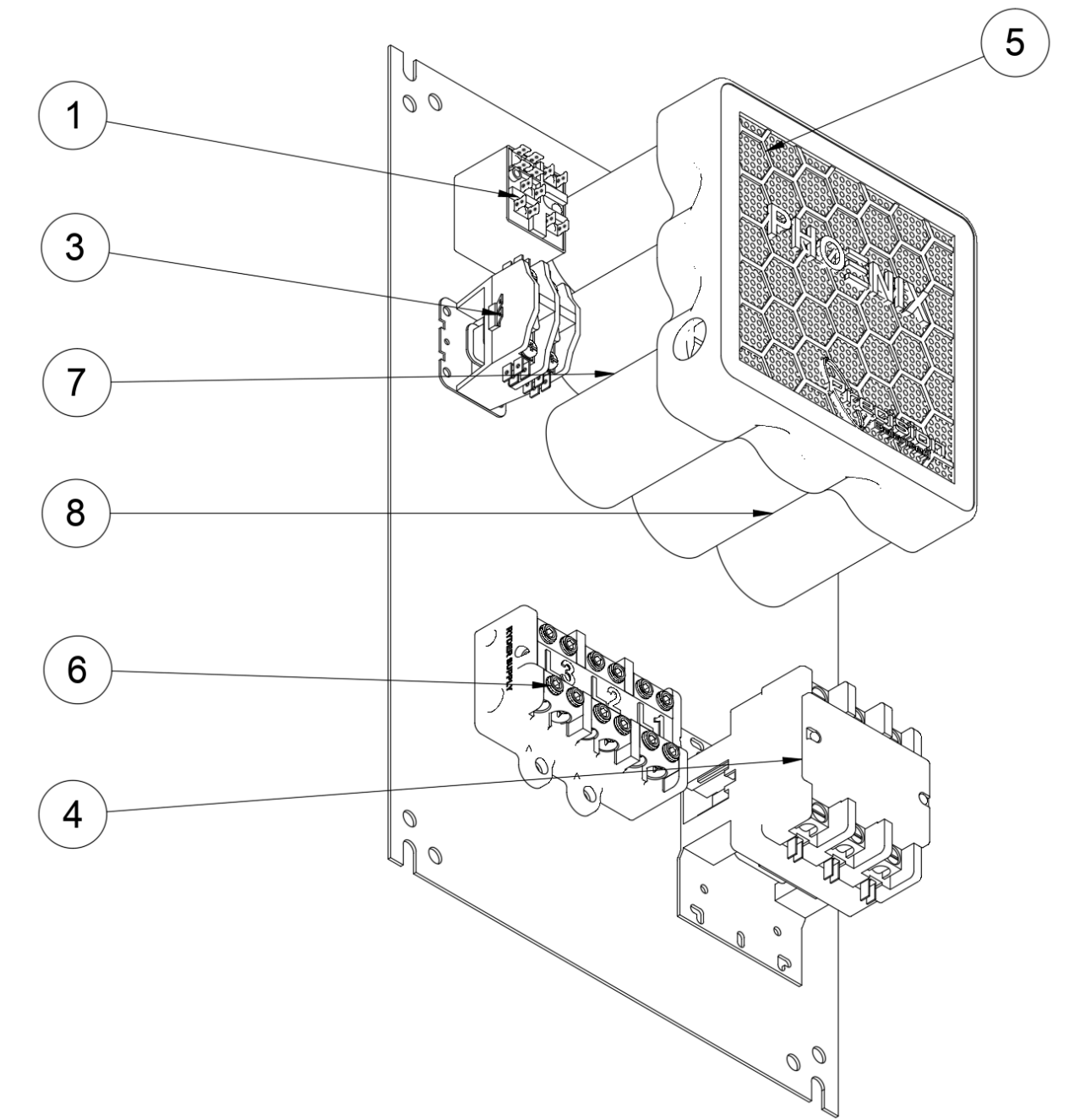

Weight: 25 HP = 330.75

Weight: 30 HP = 396.9 lbs