





Specification:

1. Finish: White
2. Hardware: 242MB ( 4 pcs )
3. Hinge: 700.0537.25+600.1234.05 ( 4 pcs )
4. Slide: USE58-300-18+US-CLIP-4W ( 2 set )
5. Jewel Case: TOSSI4-REPL ( 2 pcs )
6. Lid Stay ( 2 pcs )
7. Bowl: H8910WH
8. The tolerance is +/- 1/8"

	ITEM#: VN-WAV-48-WH-XX		MATERIAL:		
	FINISH:		WEIGHT: 9		
<b>PROPRIETARY AND CONFIDENTIAL</b> THE INFORMATION CONTAINED IN THIS DRAWING IS THE SOLE PROPERTY OF HARDWARE RESOURCES INC. ANY REPRODUCTION IN PART OR AS A WHOLE WITHOUT THE WRITTEN PERMISSION OF HARDWARE RESOURCES INC. IS PROHIBITED.	TOLERANCE UNLESS OTHERWISE SPECIFIED: X ±0.20 X.X ±0.10 X.XX ±0.05 ANGULAR: ±0.5°		UNITS:	DRAWN BY: <b>Alexander.W</b>	DATE: Jan-17-19
	DO NOT SCALE DRAWING		SIZE:	APPROVED BY:	DATE:
			SHEET:	RELEASE LEVEL:	REVISION:
					

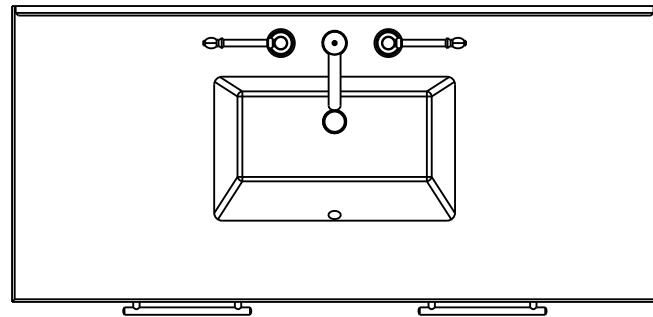
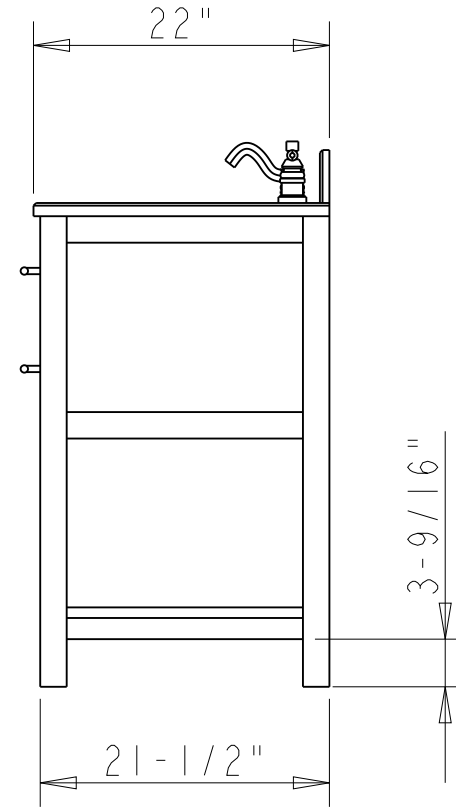
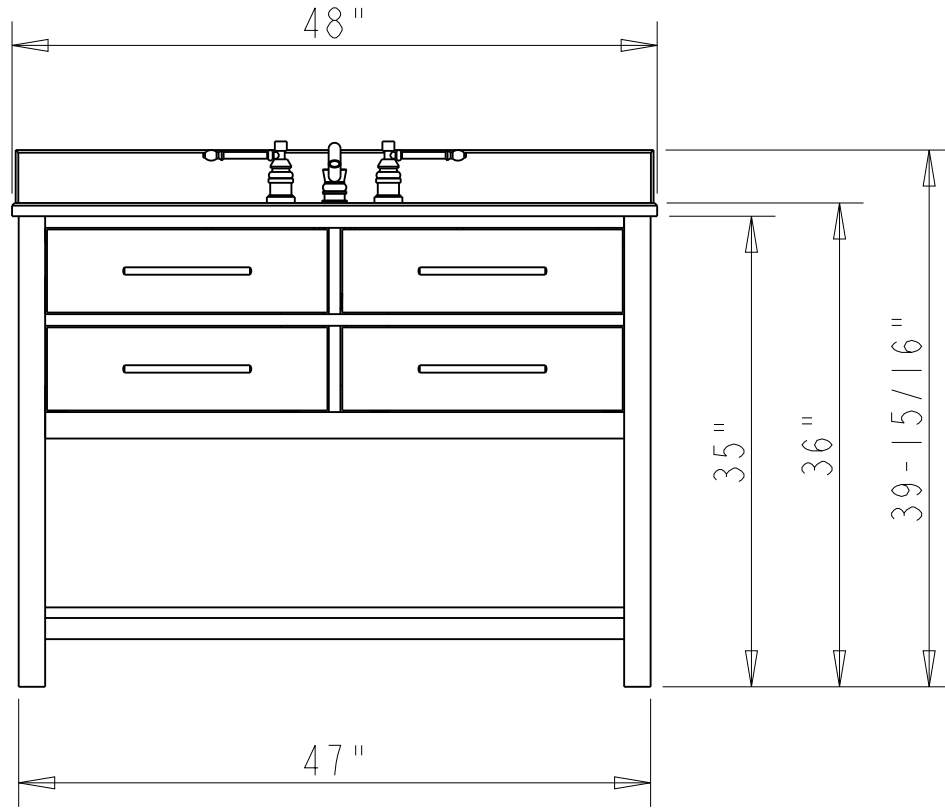

	ITEM#: VN-WAV-48-WH-XX		MATERIAL:		
	FINISH:		WEIGHT:		
<p><b>PROPRIETARY AND CONFIDENTIAL</b></p> <p>THE INFORMATION CONTAINED IN THIS DRAWING IS THE SOLE PROPERTY OF HARDWARE RESOURCES INC. ANY REPRODUCTION IN PART OR AS A WHOLE WITHOUT THE WRITTEN PERMISSION OF HARDWARE RESOURCES INC. IS PROHIBITED.</p> <p>DO NOT SCALE DRAWING</p>	<p>TOLERANCE UNLESS OTHERWISE SPECIFIED:</p> <p>X ±0.20</p> <p>X.X ±0.10</p> <p>X.XX ±0.05</p> <p>ANGULAR: ±0.5°</p>		<p>UNITS:</p>	<p>DRAWN BY:</p> <p><b>Alexander.W</b></p>	<p>DATE:</p> <p>Jan-17-19</p>
	<p>SIZE:</p>		<p>APPROVED BY:</p>		<p>DATE:</p>
	<p>SHEET:</p>		<p>RELEASE LEVEL:</p>		<p>REVISION:</p>
	<p>PROJECTION</p> 				

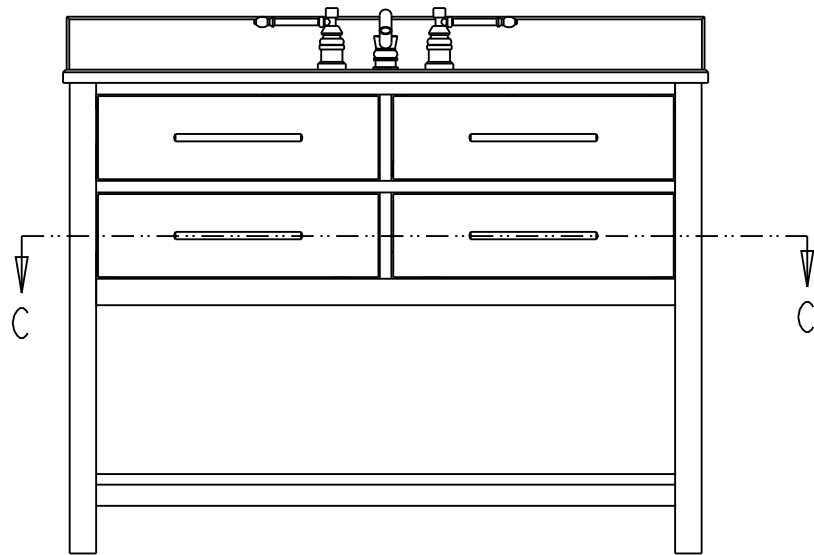

DETAIL A

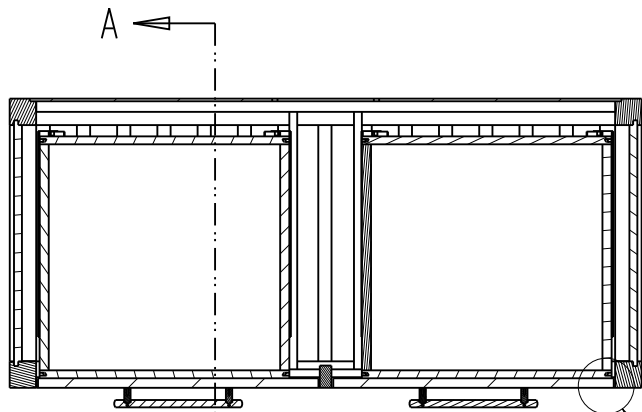
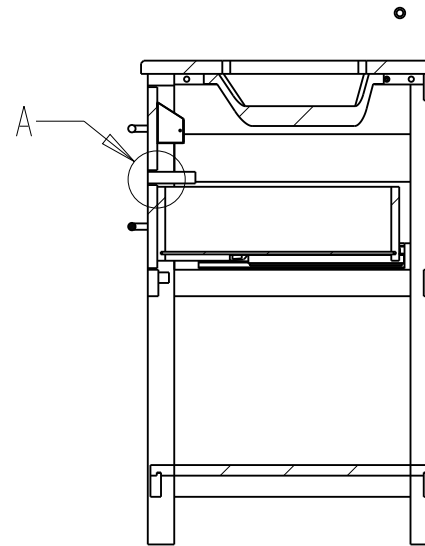

A

A

SECTION C-C

DETAIL B

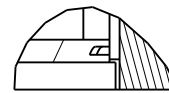

DETAIL B  
SCALE 0.200

SECTION A-A

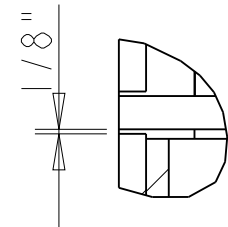

DETAIL A  
SCALE 0.200

	ITEM:	VN-WAV-48-WH-XX	MATERIAL:	
	FINISH:		WEIGHT:	9
<p><b>PROPRIETARY AND CONFIDENTIAL</b></p> <p>THE INFORMATION CONTAINED IN THIS DRAWING IS THE SOLE PROPERTY OF HARDWARE RESOURCES INC. ANY REPRODUCTION IN PART OR AS A WHOLE WITHOUT THE WRITTEN PERMISSION OF HARDWARE RESOURCES INC. IS PROHIBITED.</p> <p>DO NOT SCALE DRAWING</p>	TOLERANCE UNLESS OTHERWISE SPECIFIED:	UNITS:	DRAWN BY:	DATE:
	X ±0.20		<b>Alexander.W</b>	Jan-17-19
	X.X ±0.10	SIZE:	APPROVED BY:	DATE:
	X.XX ±0.05	SHEET:	RELEASE LEVEL:	REVISION:
ANGULAR: ±0.5°				