

# Lindab **SR Cutter**

User manual

# Content

Contents	2
SR Cutter 103427	2
Technical data	3
Accessories	3
Presentation	4
Preparations for cutting	5
Instructions for cutting	7
Making notches	10
Moving the bench	11
Problem solving	12
Bench (SR Cutter)	14
Spare parts	14
Shears (Dräco 3514-7R)	15
Spare parts	15
Click pliers	16
Spare parts	16
Contact	17
Declaration of Conformity	18

## SR Cutter 103427

### Safety instructions

Read through the manual before you start using the SR Cutter. Keep the manual to hand so that everyone who uses the SR Cutter has access to the manual.

- 1 Wear protective goggles**  
Risk of chips from the nibbling machine. Risk when cutting the duct's needle.
- 2 Use protective gloves**  
Risk of cut injury when handling the duct.
- 3 Wear ear defenders**  
The noise level can vary when cutting the ducts, sometimes it exceeds 85 dB(A). Always wear ear defenders to protect yourself.
- 4 Make sure the stand is steady**  
Never use the stand on uneven or unsteady surfaces. Make sure the legs are extended correctly and secured tightly before use.
- 5 Do not overload the stand**  
Do not exceed the maximum workload. Do not climb, sit or stand on the stand.
- 6 Do not use in a humid environment**  
Risk of electrical short circuit, use together with earth fault breaker.
- 7 Protect the electric cable**  
Risk of damage to the cable from sharp plate edges.
- 8 Assembly and disassembly**  
Use the handle to make assembly easier.
- 9 Moving**  
The SR Cutter must be moved on its own wheels. Avoid heavy loads.

## Technical data

### Bench – collapsed

Length	1645	mm
Width	470	mm
Height	350	mm

Part name	Part nr
SRCS2 3000	103 427
SRCS2 3000 US	103 428

### Bench – erected

Length	1880	mm
Length (with extended telescope arm)	3140	mm
Width	630	mm
Height	1180	mm

Maximum permitted load	75,0	kg
Weight	23,0	kg



## Accessories

### Shears

Model	3514-7R
Power	500 W
Voltage	230 V
Stroke frequency	2400 /min
Weight	2,2 kg



CSS EU 230	226 607
CSS UK 110	226 609
CSS CH 230	226 608
CSS US 110	100 886

### Needle plier

Length	200	mm
Weight	0,35	kg



NCP	226 618
-----	---------

### Click plier, small (Ø 80-224)

Length	290	mm
Weight	1,0	kg



CSCP 40	100 754
CSCP 60	100 755

### Click plier, large (Ø 250-315)

Length	290	mm
Weight	1,1	kg

### Arm for click plier

Length	210	mm
Weight	0,6	kg



CSCPS 2	103 430
---------	---------

# Presentation

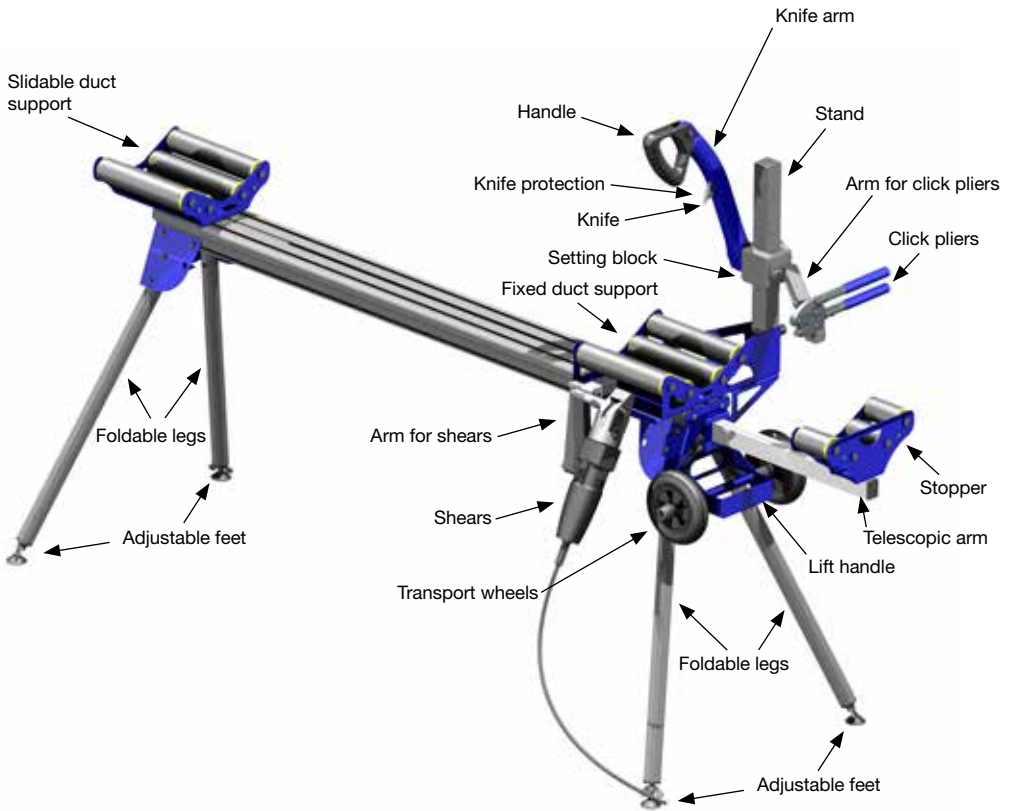

With this workbench you can cut ducts of 80-315 mm diameters and lengths of 200 mm and upwards.

The bench is equipped with:

- Wheels and foldable legs so you can easily move it to wherever you are currently installing ducts.
- Scale for setting the desired duct length.
- Knife to make a hole for the shears.

Accessories:

- Shears to cut the duct.
- Pliers to cut the inner and outer needle.
- Arm for attaching click pliers.
- Pliers to make the notches.

# Preparations for cutting

## Fold out the bench

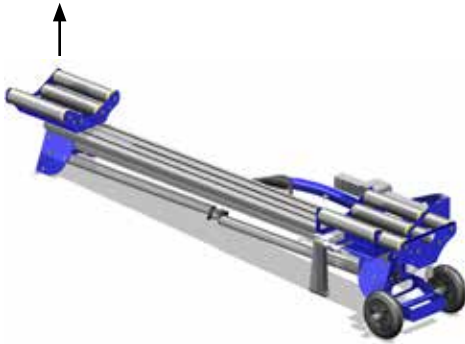

1. Lift the bench opposite the wheel side.
2. Press in the buttons and turn out the legs until the buttons have snapped into the correct position for unfolded legs.



3. Lift the bench by the handle on the wheel side.
4. Press in the buttons and turn out the legs until the buttons have snapped into the correct position for unfolded legs.

---

## Erect the stand

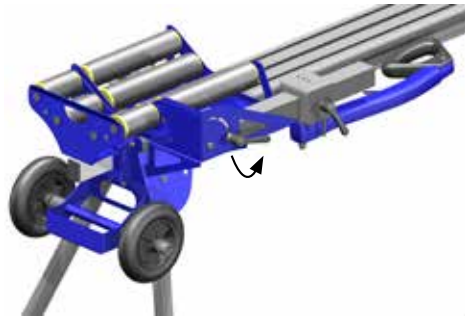

1. Loosen the locking handle on the stand.
2. Move the stand to its vertical position.



3. Tighten the locking handle.

## Mount the shears

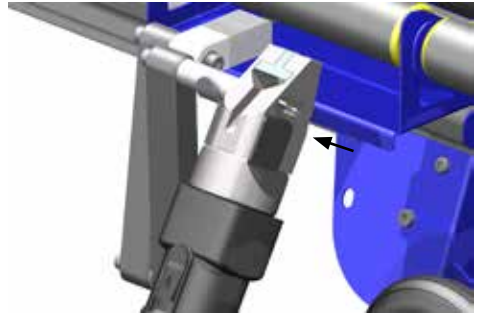
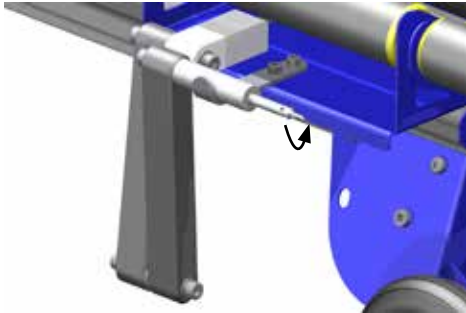

1. Turn the split pin so that it is possible to mount the shears onto the arm.
2. Mount the shears and fold back the split pin so that the pin locks.

## Mount the arm for click pliers

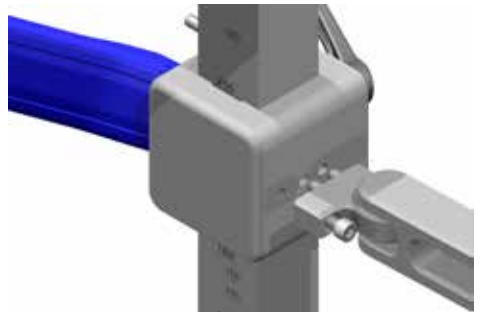
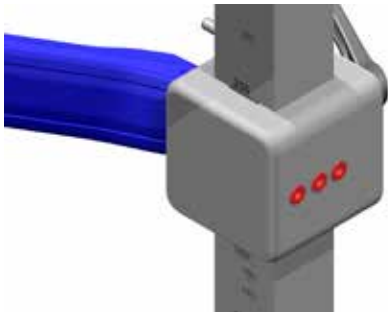

1. Remove the plastic caps from the setting block.
2. Mount the arm so that the pins fits into the holes on the setting block.
3. Tighten the screw.

# Instructions for cutting

## Set the desired duct length

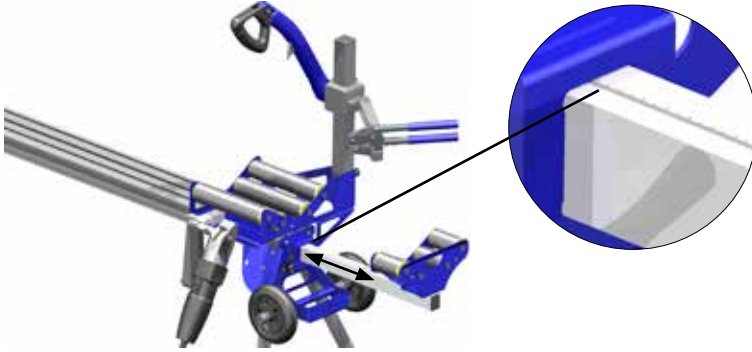

Set the desired duct length, 200–1500 mm:

1. Loosen the telescopic arm's locking handle.
2. Set the desired duct length on the scale on the telescopic arm.
3. Tighten the locking handle.

Set the desired duct length, 1500 mm and longer:

1. Measure how long the duct is that you want to cut.
2. Subtract the length you want your duct to be and the width of the knife (7 mm).
3. Set the result on the scale.

Ex. You measure the duct you have to 2500 mm. You want a duct that is 2000 mm. Set the scale to 493 mm ( $2500 - 2000 - 7 = 493$ ).

## Position the duct

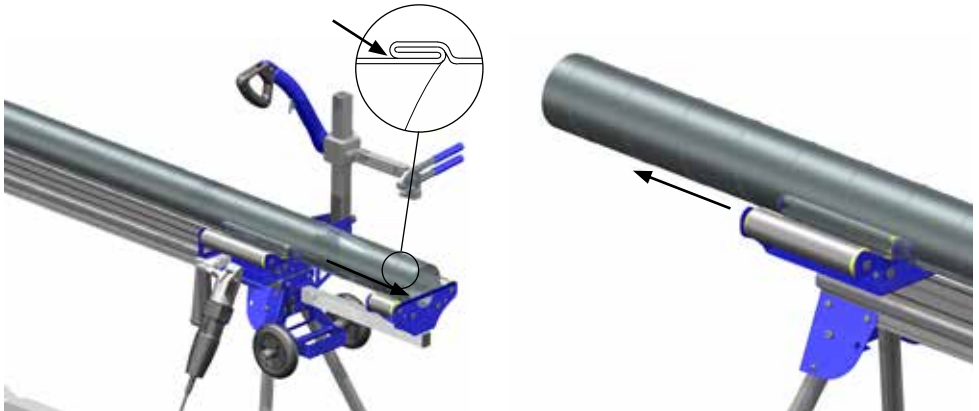

1. Turn the duct so that the opening of the fold is facing you.
2. Place the duct on the bench.
3. Push the end of the duct towards the stopper on the telescopic arm.
4. Adjust the slidable duct support so it is as close as possible to the duct end.

## Adjust the knife arm so that it matches the duct's diameter

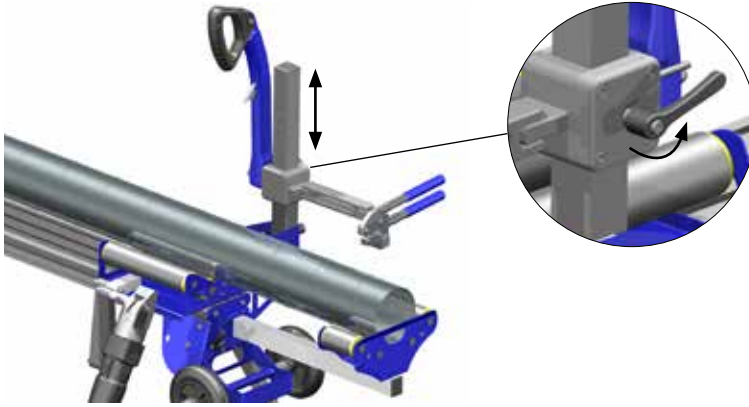

1. Loosen the locking handle on the setting block.
2. Move the block so that top of the block is at the mark of the duct's diameter.
3. Tighten the locking handle.

## Make a hole with the knife

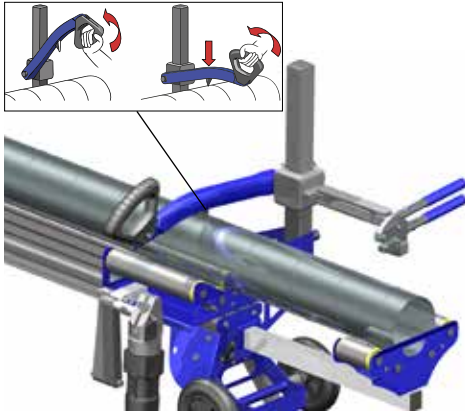

1. While moving the arm downwards turn the handle so that the knife protection is retracted.
2. Rotate the duct so the knife hits the duct a bit "before" the duct's spiral fold.
3. Hold the duct with one hand.
4. Press the knife arm firmly downwards until the knife arm touches the duct.

## Scratch a line with the knife

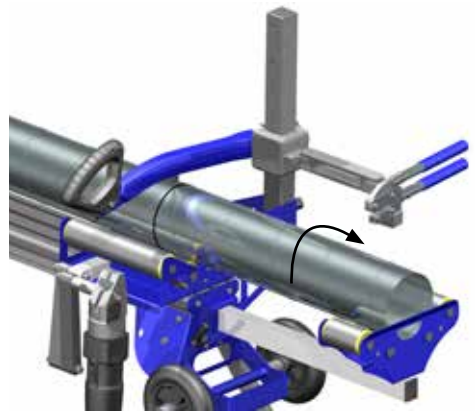

1. Scratch a thin line with the point of the knife around the duct. The easiest way to do this is turning the duct away from you.
2. Use the scratched line as a guide to cut straight.



## Cutting the duct with the shears



1. Start the shears.
2. Insert the shears' cutting tooth into the hole.
3. Turn the duct almost one full turn towards you. Make sure the scratched line is in the centre of the strip that is cut off.
4. Do not turn the last bit but hold the duct still and lead the shears forward instead.

## Cutting the needle

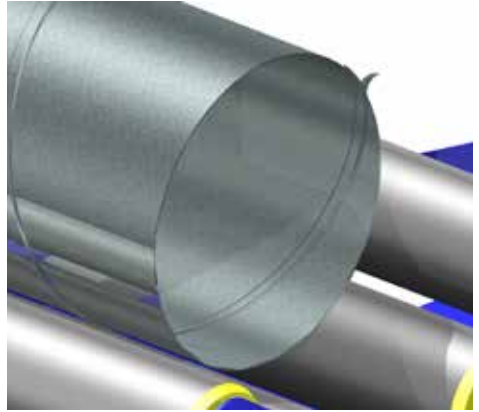

When cutting the needle Lindab recommends that you use the needle plier, NCP

Lindab recommends to cut **the outer needle** from  $\varnothing$  100 and upwards and to cut **the inner needle** from  $\varnothing$  315 and upwards.

# Making notches

## The correct click pliers



Use the correct click plier to get the notches at right distance from the ducts end.

Use the 40-pliers for  $\text{Ø } 80\text{--}224$  ( $\text{Ø } 3\text{''--}9\text{''}$ ).

Use the 60-pliers for  $\text{Ø } 250\text{--}315$  ( $\text{Ø } 10\text{''--}12\text{''}$ ).

---

## Making notches



For the recommended number of notches, see "Assembly Instructions Lindab Safe and Lindab Safe Click".

1. Insert the opening of the pliers over the duct end as far as it can reach.
2. Keep in place by holding the duct with your other hand.

3. Press the handles fully together.
4. To control the notch, see the instructions for "Checking the notch".
5. Place the notches evenly around the circumference.

You can easily loosen the pliers from the arm for separate use.

## Moving the bench



1. Push in the telescopic arm and lock the handle.
2. Move the slidable duct support as close to the fixed as possible.
3. Lower the knife arm.
4. Hold onto the handle and turn in the legs on the wheel side.

5. Move the bench as shown in the picture.

---

## Fold the bench as small as it will go e.g. for stowing in a car



1. Move the setting block so that the top of the block is above the 250 mark.
2. Move the knife arm to its vertical position.
3. Move the the stand to its horizontal position.

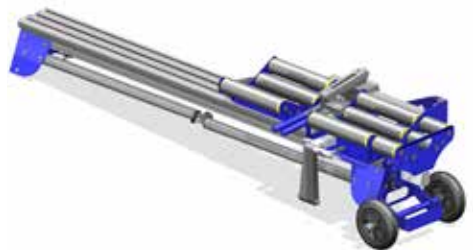

4. Move the click plier so that it is positioned horizontally above the bench between the slidable and the fixed duct support.
5. Remove the shears.
6. Turn the legs in.

# Problem solving

Problem	Cause	Solution
The knife is difficult to press through the duct.	The knife is blunt.	Remove and sharpen the knife or replace it with a new one.
	The knife arm is set at an incorrect height.	Move the setting block so that the mark above the block is the same as the diameter of the duct.
The cutting tooth of the shears cannot enter the knife hole.	The tooth does not hit the hole.	Check that the edge of the knife touches the centre of the shears' tooth.
	The hole is too small. The knife arm was not pressed all the way down to the duct when the hole was made.	Press the arm all the way down to the duct.
	The hole is too small. The knife arm is set at an incorrect height.	Move the setting block so that the mark above the block is the same as the diameter of the duct.
The duct is difficult to cut with the shears.	The shears are blunt.	Remove the cutting tooth of the shears and replace it with a new one. (After very heavy wear the side cutter may also need to be replaced.) See the chapter on spare parts.
	The opening of the fold is turned away from the shears.	Turn the duct so that the opening of the fold is facing the shears.
The fold is difficult to cut with the shears.	The knife hole was made in the wrong place.	Make the knife hole in the place, i.e. just before the fold.
	The shears are blunt.	Remove the cutting tooth of the shears and replace it with a new one. (After very heavy wear the side cutter may also need to be replaced.) See the chapter on spare parts.
	The wrong work method is being used.	Press the shears forward a bit harder but make sure you work them upwards and downwards.
The duct was not cut off properly and has a nick.	The bearing pivots points for the shears or knife are too loose.	Check that the edge of the knife touches the centre of the shears' tooth.
	The shears were forced to the left or right during cutting.	Before cutting, scratch a thin line with the point of the knife around the duct. Make sure the scratched line is in the centre of the strip that is cut off.

<b>Problem</b>	<b>Cause</b>	<b>Solution</b>
The cut duct is the wrong length.	The scale is set to an incorrect length.	Set correct length on the scale.
	During cutting, the duct was not pressed close enough to the stopper at the end of the telescopic arm.	Press the duct close to the stopper.
	The fixed duct support has come loose from the bench.	Fix the support with its two tightening screws. Make sure that the free distance between the closest edge of the shears' cutting tooth corresponds with the marking on the scale.
The click pliers make holes in the duct.	The pliers' stop screw has been screwed in too far.	Unscrew the stop screw slightly. Check how the notch looks, see instructions for "Checking the notch".
The click pliers make a faint notch.	The pliers' stop screw has been unscrewed too far.	Screw the stop screw in slightly. Check how the notch looks, see instructions for "Checking the notch".
The click plier makes dents in the duct next to the notch.	The pliers' stop screw needs adjusting due to the sheet metals thickness or quality.	Adjust the stop screw. Check how the notch looks, see instructions for "Checking the notch".

## Bench (SR Cutter)



Bench

SRCS2 3000 103 427

SRCS2 3000 US 103 428

## Spare parts



Roller (100)

CSPR2 100 103 493



Roller (250)

CSPR2 250 103 494



Arm for click plier

CSCPS2 103 430



Pin for Dräco

CSSAA2 103 498



Knife blade

CSKE2 103 496



Foot for leg

SRCSF2 103 497



Knife protection

CSKP2 112 787



Knife arm + tension block

SRCKA2 115 699



Handle, block knife arm (1)

CSHSK2 160 976



Handle, block telescopic arm (2)

CSHBT2 160 977



Handle, stand knife arm (3)

CSHBK2 160 978

## Shears (Dräco 3514-7R)



Shears 3514-7R

CSS EU 230 226 607

CSS UK 110 226 609

CSS CH 230 226 608

CSS US 110 100 886

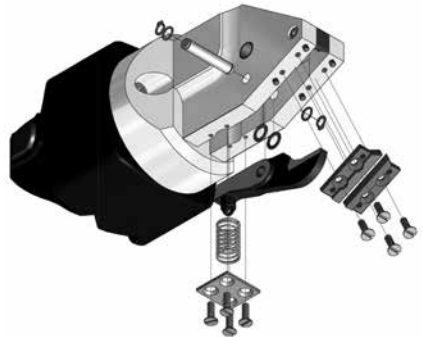

## Spare parts



Shears cutting tooth  
37140

CSSK 226 611



Pin set for shears  
cutting tooth 37140

CSSKPS 100 146



Shim set for shears cutting  
tooth 37140

CSSSSS 100 147



Side cutting edges for  
shears

SJS 226 623



Screw and pin set

SSPS 100 148

## Click pliers



Click pliers

CSCP 40 100 754

CSCP 60 100 755

## Spare parts



Gauge

CSNC 100 096



# Contact

## Belgium

Lindab N.V.  
☎ +32 9 385 5011  
[www.lindab.be](http://www.lindab.be)

## Czech Republic

Lindab s.r.o.  
☎ +420 233 107 100

## Denmark

Lindab A/S  
☎ +45 73 232323  
[www.lindab.dk](http://www.lindab.dk)

## Estonia

Lindab AS  
☎ +372 6348200  
[www.lindab.ee](http://www.lindab.ee)

## Finland

Oy Lindab Ab  
☎ +358 9 2534 4500  
[www.lindab.fi](http://www.lindab.fi)

## France

Lindab S.A  
☎ +33 4 78 06 36 41  
[www.lindab.fr](http://www.lindab.fr)

## Germany

Lindab GmbH  
☎ +49 4532 2859-0  
[www.lindab.de](http://www.lindab.de)

## Hungary

Lindab Kft.  
☎ +36 23 531 100  
[www.lindab.hu](http://www.lindab.hu)

## Ireland

Lindab (Irl) Ltd  
☎ +353 1 456 8200  
[www.lindab.ie](http://www.lindab.ie)

## Italy

Lindab S.r.l  
☎ +39 011 99 520 99  
[www.lindab.it](http://www.lindab.it)

## Latvia

Lindab SIA  
☎ +371 780 43 71  
[www.lindab.com](http://www.lindab.com)

## Lithuania

Lindab UAB  
☎ +370 52 729 729  
[www.lindab.com](http://www.lindab.com)

## Norway

Lindab A/S  
☎ +47 22 80 39 00  
[www.lindab.no](http://www.lindab.no)

## Poland

Lindab SP. z o.o.  
☎ +48 22 489 88 00  
[www.lindab.pl](http://www.lindab.pl)

## Romania

Lindab SRL  
☎ +40 21 2094 100  
[www.lindab.ro](http://www.lindab.ro)

## Russia

OOO Lindab  
☎ +7 812 360 53 60  
[www.lindab.ru](http://www.lindab.ru)

## Switzerland

Lindab AG  
☎ +41 58 800 31 00  
[www.lindab.ch](http://www.lindab.ch)

## Sweden

Lindab Sverige AB  
☎ +46 431 850 00  
[www.lindab.se](http://www.lindab.se)

## UK

Lindab Ltd  
☎ +44 1604 788 350  
[www.lindab.co.uk](http://www.lindab.co.uk)

## USA

Lindab Inc.  
☎ +1 757 488 1144  
[www.lindabusa.com](http://www.lindabusa.com)



## Declaration of Conformity

1. Declaration number	1213
2. Unique identification code of the product	SRCS2
3. Type	Smart Tool
4. Product description	Working bench/platform for cutting circular ducts of diameters Ø 80–315 and lengths 200–3000 mm.
5. Manufacturer	Lindab Ventilation AB Stålhögavägen 115, 26982 Båstad, Sweden Telephone +46 431 85000, www.lindab.com

Developed, designed and manufactured with the essential requirements by safe and security of the European Directive(s) and Regulation(s):

2006/42/EC	Machinery Directive (MD)
------------	--------------------------

The following harmonized standards are applied in applicable parts:

EN ISO 12100:2010	Safety of machinery - General principles for design - Risk assessment and risk reduction
-------------------	--

This declaration of conformity is established under the sole responsibility of the manufacturer identified in point 5.

Signed for and on behalf of the manufacturers by:

Karel Kleinmond  
Group Operations Director  
2019-01-21 Karlovarska, Czech Republic





## Good Thinking

**At Lindab**, good thinking is a philosophy that guides us in everything we do. We have made it our mission to create a healthy indoor climate – and to simplify the construction of sustainable buildings. We do that by designing innovative products and solutions that are easy to use, as well as offering efficient availability and logistics. We are also working on ways to reduce our impact on our environment and climate. We do that by developing methods to produce our solutions using a minimum of energy and natural resources, and by reducing negative effects on the environment. We use steel in our products. It's one of few materials that can be recycled an infinite number of times without losing any of its properties. That means less carbon emissions in nature and less energy wasted.

**We simplify construction**