



Barcode: 5060452082929

Patent number: 2113661.9

ductrack™

Product code: DR2

- » DuctRack stores, transports, and protects pipe or ductwork.
- » Featuring our SafeStop dead-man brake system.
- » Built in material cover reduces dust ingress and covers sharp edges.



Product features



Working load limit

1000kg



No detachable parts



Forklift skids



Heavy-duty 6" castors



Standard 200mm castors



Collapsible



Stackable

Product specifications

Weight	158kg
Colour	Black grey: RAL 7021
Finished coating	Powder coated
Material & thickness	2.5mm & 3mm steel
How are castors fitted?	Castor plates
Assembly required?	No

Dimensions

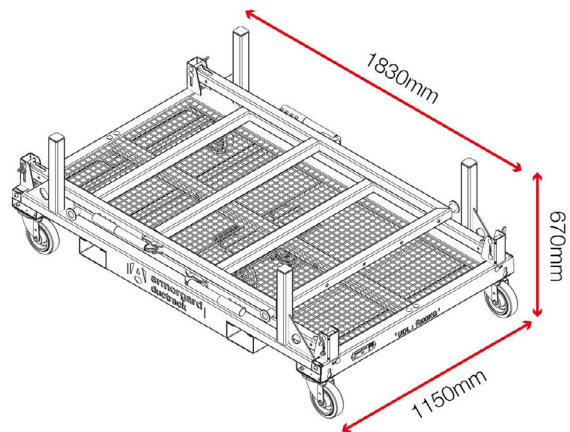

Optional extras - Contact Armorgard to find out more



Side kit DR-SK



Shelf DR1-S



Shelf DR2-S

