

SELF-PROPELLED SCISSOR LIFTS

OPERATOR'S MANUAL

with Maintenance Information

For JCPT0808/JCPT1008/JCPT1012/JCPT1212/JCPT1412/JCPT1612B/JCPT1612S

(Hydraulic Motor / DC Motor Drive)



WARNING

THE MANUFACTURER SHALL NOT BE HELD LIABLE IN CASE OF FAULTS OR ACCIDENTS DUE TO NEGLIGENCE, INCAPACITY, INSTALLATION BY UNQUALIFIED TECHNICIANS AND IMPROPER USE OF THE MACHINE

DO NOT OPERATE THIS MACHINE UNTIL YOU READ AND UNDERSTAND ALL THE DANGERS, WARNINGS AND CAUTIONS IN THIS MANUAL

Part Number: SM0110111_Rev9.7



Zhejiang Dingli Machinery Co., Ltd.

Ninth Edition, February 2020 Printing

Version of the Record**Version of the Record**

Version Number	Create Date
SM0110111_Rev1.0	2010-07
SM0110111_Rev2.0	2011-03
SM0110111_Rev3.0	2012-12
SM0110111_Rev4.0	2013-08
SM0110111_Rev5.0	2014-03
SM0110111_Rev6.0	2014-12
SM0110111_Rev7.0	2016-01
SM0110111_Rev8.0	2018-01
SM0110111_Rev9.0	2018-07
SM0110111_Rev9.1	2018-10
SM0110111_Rev9.2	2019-02
SM0110111_Rev9.3	2019-10
SM0110111_Rev9.4	2020-02
SM0110111_Rev9.5	2020-07
SM0110111_Rev9.6	2020-09
SM0110111_Rev9.7	2020-12

Important

Read, understand and obey these safety rules and operating instructions before operating this machine.

Only trained and authorized personnel shall be permitted to operate this machine. This manual should be considered a permanent part of your machine and should remain with the machine at all times. If you have any questions, please call DINGLI Machinery.

Contents

	Page
Safety Rules	1
Legend	10
Decals	11
Specifications	16
Control panel	31
Pre-operation Inspection	34
Workplace Inspection	36
Function Tests	37
Operating Instructions	42
Transport and Lifting Instructions	54
Storage	58
Maintenance	59
Schematic	88
Inspection and Repair Log	98

Owners, Users and operators:

We appreciate your choice of our machine for your application. Our number one priority is user safety, which is best achieved by our joint efforts. We feel that you make a major contribution to safety if you, as the equipment users and operators:

- 1 Comply with employer, job site and governmental rules.
- 2 Read, understand and follow the instructions in this and other manuals supplied with this machine.
- 3 Use good safe work practices in a commonsense way.
- 4 Only have trained / certified operators, directed by informed and knowledgeable supervision, running the machine.

If there is anything in this manual that is not clear or which you believe should be added, please contact us.

Contact us:

Zhejiang Dingli Machinery Co., Ltd.

1255 Baiyun South Road. Leidian Town.

Deqing Zhejiang

China

Tel: +86-572-8681688

Fax: +86-572-8681690

Web: www.cndingli.com

E-mail: market@cndingli.com

Safety Rules



Danger

Failure to obey the instructions and safety rules in this manual will result in death or serious injury.

Do Not Operate Unless:

- You learn and practice the principles of safe machine operation contained in this operator's manual.
 - 1 Avoid hazardous situations.**
 - Know and understand the safety rules before going on to the next section.**
 - 2 Always perform a pre-operation inspection.
 - 3 Always perform function tests prior to use.
 - 4 Inspect the workplace.
 - 5 Only use the machine as it was intended.
- You read, understand and obey the manufacturer's instructions and safety rules — operator's manual and machine decals.
- You read, understand and obey employer's safety rules and worksite regulations.
- You read, understand and obey all applicable governmental regulations.
- You are properly trained to safely operate the machine.

Decal Legend

DINGLI product decals use symbols, color coding and signal words to identify the following:



Safety alert symbol — used to alert personnel to potential personal injury hazards. Obey all safety messages that follow this symbol to avoid possible injury or death.

▲ DANGER Red — used to indicate the presence of an imminently hazardous situation which, if not avoided, will result in death or serious injury.

▲ WARNING Orange — used to indicate the presence of a potentially hazardous situation which, if not avoided, could result in death or serious injury.

▲ CAUTION Yellow with safety alert symbol — used to indicate the presence of a potentially hazardous situation which, if not avoided, may cause minor or moderate injury.

NOTICE Blue without safety alert symbol — used to indicate the presence of a potentially hazardous situation which, if not avoided, may result in property damage.

Safety Rules

The relevant conditions of using the equipment

The surface of work ground should be flat and hard with no obstacles in air and the safety distance between the equipment and high-tension line is adequate.

The environment temperature should be within -20°C~40°C; Height above sea level ≤1000m.

The environment humidity ≤ 90%.

Electrical power: AC 110~230V±10%, 50~60Hz.

Intended Use

This machine is intended to be used only to lift personnel, along with their tools and materials to an aerial work site.

Safety Sign Maintenance

Replace any missing or damaged safety signs. Keep operator safety in mind at all times.

Use mild soap and water to clean safety signs.

Do not use solvent-based cleaners because they may damage the safety sign material.

⚠ Electrocutation Hazard

This machine is not electrically insulated and will not provide protection from contact with or proximity to electrical current.

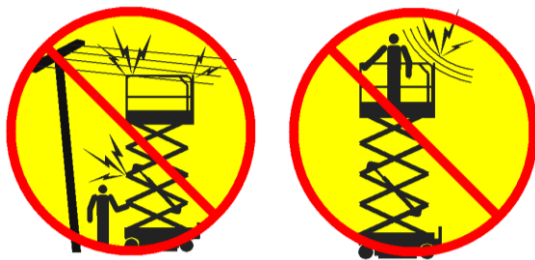

Maintain safe distances from electrical power lines and apparatus in accordance with

applicable governmental regulations and the following chart.

Voltage Phase to Phase	Minimum Safe Approach Distance Meters
0 to 300V	Avoid Contact
300V to 50kV	3.05
50kV to 200kV	4.60
200kV to 350kV	6.10
350kV to 500kV	7.62
500kV to 750kV	10.67
750kV to 1000kV	13.72

Allow for platform movement, electrical line sway or sag and beware of strong or gusty winds.

Keep away from the machine if it contacts energized power lines. Personnel on the ground or in the platform must not touch or operate the machine until energized power lines are shut off.

Do not operate the machine during lightning or storms.

Do not use the machine as a ground for welding.

⚠ Tip-over Hazard

Occupants, equipment and materials must not exceed the maximum platform capacity or the maximum capacity of the platform extension.

Maximum capacity – JCPT0808HD

Maximum occupants (Indoor use)	2
Maximum occupants (Outdoor use)	1
Platform allowable maximum load	380kg
Extension deck allowable maximum load	113kg

Maximum capacity – JCPT1008HD

Maximum occupants (Indoor use ONLY)	2
---	---

Safety Rules

Platform allowable maximum load 230kg

Extension deck allowable maximum load 113kg

Maximum capacity – JCPT1012HD

Maximum occupants (Indoor / Outdoor use) 2

Platform allowable maximum load 450kg

Extension deck allowable maximum load 113kg

Maximum capacity – JCPT1212HD

Maximum occupants (Indoor use) 2

Maximum occupants (Outdoor use) 1

Platform allowable maximum load 320kg

Extension deck allowable maximum load 113kg

Maximum capacity – JCPT1412HD

Maximum occupants (Indoor use **ONLY**) 3

Platform allowable maximum load 320kg

Extension deck allowable maximum load 113kg

Maximum capacity – JCPT1612HDB

Maximum occupants (Indoor use **ONLY**) 2

Platform allowable maximum load 250kg

Extension deck allowable maximum load 113kg

Maximum capacity – JCPT1612HDS

Maximum occupants (Indoor use **ONLY**) 2

Platform allowable maximum load 250kg

Extension deck allowable maximum load 113kg

Maximum capacity – JCPT0808DC

Maximum occupants (Indoor use) 2

Maximum occupants (Outdoor use) 1

Platform allowable maximum load 380kg

Extension deck allowable maximum load 113kg

Maximum capacity – JCPT1008DC

Maximum occupants (Indoor use **ONLY**) 2

Platform allowable maximum load 230kg

Extension deck allowable maximum load 113kg

Maximum capacity – JCPT1012DC

Maximum occupants (Indoor/Outdoor use) 2

Platform allowable maximum load 450kg

Extension deck allowable maximum load 113kg

Maximum capacity – JCPT1212DC

Maximum occupants (Indoor use) 2

Maximum occupants (Outdoor use) 1

Platform allowable maximum load 320kg

Extension deck allowable maximum load 113kg

Maximum capacity – JCPT1412DC

Maximum occupants (Indoor use **ONLY**) 3

Platform allowable maximum load 320kg

Extension deck allowable maximum load 113kg

Maximum capacity – JCPT1612DCB

Maximum occupants (Indoor use **ONLY**) 2

Platform allowable maximum load 250kg

Extension deck allowable maximum load 113kg

Maximum capacity – JCPT1612DCS

Maximum occupants (Indoor use **ONLY**) 2

Platform allowable maximum load 250kg

Extension deck allowable maximum load 113kg

Platform retracted

Platform extended



Extension only Platform only

Work Area Safety

Do not raise the platform unless the machine is on a firm, level surface.

Do not drive over 0.8 km/h with the platform raised.

Safety Rules



Do not depend on the tilt alarm as a level indicator. The tilt alarm sounds on the chassis and in the platform when the machine is on a slope.

If the tilt alarm sounds:

Lower the platform. Move the machine to a firm, level surface. If the tilt alarm sounds when the platform is raised, use extreme caution to lower the platform.

For outdoor use machine, do not raise the platform when wind speeds may exceed 12.5 m/s. If wind speeds exceed 12.5 m/s when the platform is raised, lower the platform and do not continue to operate the machine.

Do not operate the machine in strong or gusty winds. Do not increase the surface area of the platform or the load. Increasing the area exposed to the wind will decrease machine stability.



Do not use the platform controls to free a platform that is caught, snagged or otherwise prevented from normal motion by an adjacent structure. All personnel must be removed from the platform before attempting to free the platform using the ground controls.

Use extreme care and slow speeds while driving the machine in the stowed position across uneven terrain, debris, unstable or slippery surfaces and near holes and

drop-offs.

Do not drive the machine on or near uneven terrain, unstable surfaces or other hazardous conditions with the platform raised.

Do not push off or pull toward any object outside of the platform.



Maximum allowable manual force

Model	Application	manual force	Maximum occupants
JCPT0808HD	Outdoor	200N	1
	Indoor	400N	2
JCPT1008HD	Indoor	400N	2
JCPT1012HD	Outdoor	400N	2
	Indoor	400N	2
JCPT1212HD	Outdoor	200N	1
	Indoor	400N	2
JCPT1412HD	Indoor	400N	3
JCPT1612HDB	Indoor	400N	2
JCPT1612HDS	Indoor	400N	2
JCPT0808DC	Outdoor	200N	1
	Indoor	400N	2
JCPT1008DC	Indoor	400N	2
JCPT1012DC	Outdoor	400N	2
	Indoor	400N	2
JCPT1212DC	Outdoor	200N	1
	Indoor	400N	2
JCPT1412DC	Indoor	400N	3
JCPT1612DCB	Indoor	400N	2
JCPT1612DCS	Indoor	400N	2

Safety Rules

Do not use the machine as a crane.

Do not place or attach fixed or overhanging loads to any part of this machine.

Do not push the machine or other objects with the platform.

Do not operate the machine with the chassis trays open.

Do not contact adjacent structures with the platform.

Do not alter or disable the limit switches.

Do not tie the platform to adjacent structures.

Do not place loads outside the platform perimeter.



Do not alter or disable machine components that in any way affect safety and stability.

Do not replace items critical to machine stability with items of different weight or specification.

Do not use batteries that weigh less than the original equipment. Batteries are used as counterweight and are critical to machine stability. Each battery must weigh 28 kg. The batteries must weigh a minimum of 112 kg. (For JCPT0808HD/DC, JCPT1008HD/DC, JCPT1012HD/DC); Each battery must weigh 30 kg. The batteries must weigh a minimum of 120 kg (For JCPT1212HD/DC); Each battery must weigh 37 kg. The batteries must weigh a minimum of 148 kg (For JCPT1412HD/DC, JCPT1612HDB/DCB, JCPT1612HDS/DCS).

Do not modify or alter an aerial work platform without prior written permission from the manufacturer. Mounting attachments for

holding tools or other materials onto the platform, toe boards or guard rail system can increase the weight in the platform and the surface area of the platform or the load.

Do not place ladders or scaffolds in the platform or against any part of this machine.

Do not transport tools and materials unless they are evenly distributed and can be safely handled by person(s) in the platform.

Do not use the machine on a moving or mobile surface or vehicle.

Be sure all tires are in good condition, air-filled tires are properly inflated and lug nuts are properly tightened.

▲ Crushing Hazard

Keep hands and limbs out of scissors.

Keep hands clear when folding rails.

Maintain a firm grasp on the platform rail when removing the rail pins. Do not allow the platform guard rails to fall.

Use common sense and planning when operating the machine with the controller from the ground. Maintain safe distances between the operator, the machine and fixed objects.

▲ Operation on Slopes Hazard

Do not drive the machine on a slope that exceeds the slope and side slope rating of the machine.

Slope rating applies to machines only in the stowed position.



Maximum slope rating stowed

Safety Rules

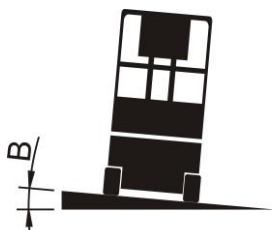

Maximum side slope rating stowed

Model	A	B
JCPT0808HD	25% (14°)	25% (14°)
JCPT1008HD	25% (14°)	25% (14°)
JCPT1012HD	25% (14°)	25% (14°)
JCPT1212HD	25% (14°)	25% (14°)
JCPT1412HD	25% (14°)	25% (14°)
JCPT1612HDB	25% (14°)	25% (14°)
JCPT1612HDS	25% (14°)	25% (14°)
JCPT0808DC	25% (14°)	25% (14°)
JCPT1008DC	25% (14°)	25% (14°)
JCPT1012DC	25% (14°)	25% (14°)
JCPT1212DC	25% (14°)	25% (14°)
JCPT1412DC	25% (14°)	25% (14°)
JCPT1612DCB	25% (14°)	25% (14°)
JCPT1612DCS	25% (14°)	25% (14°)

Note: Slope rating is subject to ground conditions and adequate traction.

▲ Fall Hazard

The guard rail system provides fall protection. During operation, occupants in the platform must wear a full body harness with a lanyard attached to an authorized lanyard anchorage point. Attach only one (1) lanyard per lanyard anchorage point.

Do not sit, stand or climb on the platform guard rails. Maintain a firm footing on the platform floor at all times.



Do not climb down from the platform when raised.

Keep the platform floor clear of debris.

Close the entry gate before operating.

Do not operate the machine unless the guard rails are properly installed and the entry is secured for operation.

Do not enter or exit the platform unless the machine is in the stowed position.

▲ Collision Hazard



Be aware of limited sight distance and blind spots when driving or operating.

Be aware of extended platform position(s) when moving the machine.

Check the work area for overhead obstructions or other possible hazards.



Be aware of crushing hazards when grasping the platform guard rail.

Operators must comply with employer, job site and governmental rules regarding use of personal protective equipment.

Observe and use color-coded direction arrows

Safety Rules

on the platform controls for drive and steer functions.

Do not operate a machine in the path of any crane or moving overhead machinery unless the controls of the crane have been locked out and/or precautions have been taken to prevent any potential collision.

No stunt driving or horseplay while operating a machine.

Do not lower the platform unless the area below is clear of personnel and obstructions.



Limit travel speed according to the condition of the ground surface, congestion, slope, location of personnel, and any other factors which may cause collision.

⚠ Component Damage Hazard

Do not use any battery charger greater than 24V to charge the batteries.

Do not use the machine as a ground for welding.

⚠ Explosion and Fire Hazard

Do not operate the machine or charge the batteries in hazardous locations where potentially flammable or explosive gases or particles may be present.

⚠ Damaged Machine Hazard

Do not use a damaged or malfunctioning machine.

Conduct a thorough pre-operation inspection of the machine and test all functions before each work shift. Immediately tag and remove from service a damaged or malfunctioning machine.

Be sure all maintenance has been performed as specified in this manual.

Be sure all decals are in place and legible.

Be sure the operator's manual is complete, legible and in the storage container located in the platform.

⚠ Bodily Injury Hazard

Do not operate the machine with a hydraulic oil or air leak. An air leak or hydraulic leak can penetrate and/or burn skin.

Improper contact with components under any cover will cause serious injury. Only trained maintenance personnel should access compartments. Access by the operator is only advised when performing a pre-operation inspection. All compartments must remain closed and secured during operation.

⚠ Battery Safety

⚠ Burn Hazard



Batteries contain acid. Always wear protective clothing and eye wear when working with batteries.

Avoid spilling or contacting battery acid. Neutralize battery acid spills with baking soda and water.

Rinse eyes or skin splashed with acid using plenty of clean water and consult a doctor

Safety Rules

immediately. Wash clothing contaminated with acid with plenty of water.

▲ Explosion Hazard



Keep sparks, flames and lighted tobacco away from batteries. Batteries emit explosive gas.

Avoid fire and risk of explosion caused by short circuits.

The battery tray should remain open during the entire charging cycle.

Do not contact the battery terminals or the cable clamps with tools that may cause sparks.

▲ Component Damage Hazard

Do not use any battery charger greater than 24V to charge the batteries.

Pressure relief valves are used as breathable plugs. If open the pressure relief valves, the battery will be destroyed.

The battery must always be kept clean and dry in order to prevent leakage currents. Do not rinse with water or wipe with a wet towel.

Please do not change the location of the battery, and cannot be inverted. Do not block the vent hole of safety valve when placing.

The series/parallel connection must be approved by Dingli. Only accessories approved by Dingli can be used for connection of battery blocks.

▲ Electrocution/ Burn Hazard



Connect the battery charger to a grounded, AC 3-wire electrical outlet only.

Inspect daily for damaged cords, cables and wires. Replace damaged items before operating.

Metallic parts of the battery cells are always electriferous. Therefore, no foreign objects or tools may be placed on the batteries.

Avoid electrical shock from contact with battery terminals. Remove all rings, watches and other jewelry.

▲ Tip-over Hazard

Do not use batteries that weigh less than the original equipment. Batteries are used as counterweight and are critical to machine stability. Each battery must weigh 28 kg. The batteries must weigh a minimum of 112 kg. (For JCPT0808HD/DC, JCPT1008HD/DC, JCPT1012HD/DC); Each battery must weigh 30 kg. The batteries must weigh a minimum of 120 kg (For JCPT1212HD/DC); Each battery must weigh 37 kg. The batteries must weigh a minimum of 148 kg (For JCPT1412HD/DC, JCPT1612HDB/DCB, JCPT1612HDS/DCS).

▲ Lifting Hazard

Use the appropriate number of people and proper lifting techniques when lifting batteries.

Lifting hooks must not cause any damage to cells, connectors or connecting cables.

▲ Environmental Hazard

30°C battery temperature is considered the rated temperature. Higher temperatures reduce the service life, while lower temperatures reduce the available capacity. 45°C is the upper limit temperature and is not permissible as an operating temperature.

Batteries must not be exposed to sunlight without protection.

Safety Rules

▲ Transportation and storage

Hazard

Charge the battery as soon as receive the machine or after long distance transportation

When the battery is stored for a long time, it needs to be charged regularly. Failure to charge in time may permanently damage the battery.

▲ pollute Hazard



Old batteries with this marking are recyclable goods and must be sent for recycling.

Used batteries which are not sent for recycling are to be disposed of as special waste under the relevant regulations

Lockout after Each Use

- 1 Select a safe parking location - firm level surface, clear of obstruction and traffic.
- 2 Lower the platform.
- 3 Turn the key switch to the off position and remove the key to secure from unauthorized use.
- 4 Push in the red Emergency Stop buttons to "off" position.
- 5 Push in the main power switch to "off" position
- 6 Chock the wheels.
- 7 Charge the batteries.

Legend

Legend

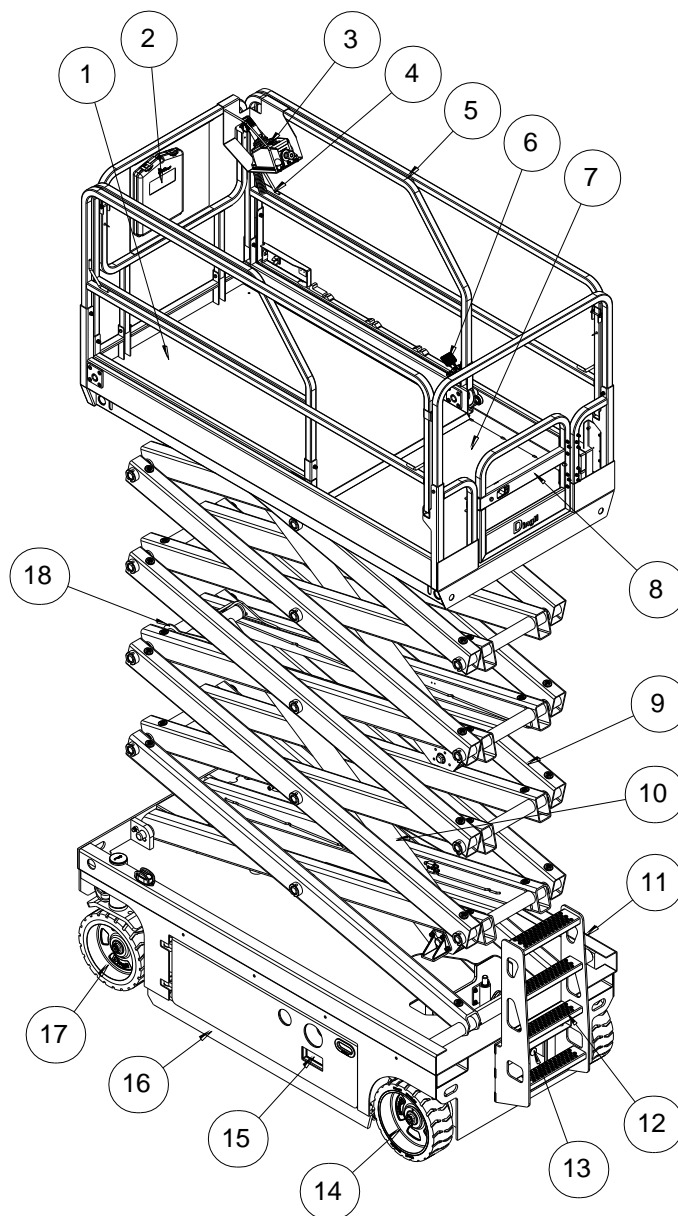

- | | |
|------------------------------------|--|
| 1 Platform extension | 10 Lift cylinder |
| 2 Manual storage container | 11 Ground controls (on opposite side of machine) |
| 3 Platform control | 12 Entry ladder |
| 4 Lanyard anchorage point | 13 Brake release pump |
| 5 Platform guard rails | 14 Non-steer tire |
| 6 Platform extension release pedal | 15 Battery charger |
| 7 Main platform | 16 Pothole guard |
| 8 Platform entry gate | 17 Steer tire |
| 9 Scissor arms | 18 Safety arm |

Decals**Decal Inspection**

Use the pictures on the next page to verify that all decals are legible and in place.

Below is a numerical list with quantities and descriptions.

No.	Part No.	Description	Qty.	Remark
1	09440011	Decal, Label-Lanyard anchorage point	4	
2	09340001	Decal, Notice-Keep the manual with the machine	1	
3	09440001	Decal, Danger-General safety rules	1	
4	09440003	Decal, Danger-Tip-over hazard, tilt-alarm	1	
5	09340003	Decal, Instructions-Refer the operator to the instructions for use	2	
6	09440013	Decal, Label-Capacity 380kg	1	JCPT0808HD/DC
	09440014	Decal, Label-Capacity 230kg	1	JCPT1008HD/DC
	09440015	Decal, Label-Capacity 450kg	1	JCPT1012HD/DC
	09440016	Decal, Label-Capacity 320kg	1	JCPT1212HD/DC
	09440017	Decal, Label-Capacity 320kg	1	JCPT1412HD/DC
	09440038	Decal, Label-Capacity 250kg	1	JCPT1612HDB/DCB JCPT1612HDS/DCS
7	09440005	Decal, Warning-Use indoors only	1	JCPT1008HD/DC JCPT1412HD/DC JCPT1612HDB/DCB JCPT1612HDS/DCS
8	09310001	Decal, Instructions-Forklift pockets	2	
9	09310003	Decal, Instructions-Tie down point	4	
10	09310002	Decal, Instructions-Lift point	4	
11	09310008	Decal, Instructions-Maximum wheel load: 1000kg	4	JCPT0808HD/DC
	09310010	Decal, Instructions-Maximum wheel load: 960kg	4	JCPT1008HD/DC
	09310012	Decal, Instructions-Maximum wheel load: 1240kg	4	JCPT1012HD/DC
	09310014	Decal, Instructions-Maximum wheel load: 1310kg	4	JCPT1212HD/DC
	09310016	Decal, Instructions-Maximum wheel load: 1280kg	4	JCPT1412HD/DC
	09310018	Decal, Instructions-Maximum wheel load: 1350kg	4	JCPT1612HDB/DCB JCPT1612HDS/DCS

Decals

No.	Part No.	Description	Qty.	Remark
12	09310006	Decal, Notice-Main power switch operation	1	
13	09540001	Decal, Label-CE	3	
14	09410129	Decal, Warning-Charge warning	1	
15	09410001	Decal, Danger-Explosion/burn hazard	1	
16	09430003	Decal, Danger-Keep away from moving parts	3	JCPT0808HD/DC JCPT1008HD/DC JCPT1012HD/DC JCPT1212HD/DC
	09430003	Decal, Danger-Keep away from moving parts	5	JCPT1412HD/DC JCPT1612HDB/DCB JCPT1612HDS/DCS
17	09430001	Decal, Danger-Safety arm	2	JCPT0808HD/DC JCPT1008HD/DC JCPT1012HD/DC JCPT1212HD/DC
	09430001	Decal, Danger-Safety arm	4	JCPT1412HD/DC JCPT1612HDB/DCB JCPT1612HDS/DCS
18	09440009	Decal, Caution-Max. manual force 400N (Indoor)200N (Outdoor)	2	JCPT0808HD/DC JCPT1212HD/DC
	09440007	Decal, Caution-Max. manual force 400N	2	JCPT1008HD/DC JCPT1012HD/DC JCPT1412HD/DC JCPT1612HDB/DCB JCPT1612HDS/DCS
19	09640001	Decal, Cosmetic-JCPT0808	2	JCPT0808HD/DC
	09640002	Decal, Cosmetic-JCPT1008	2	JCPT1008HD/DC
	09640003	Decal, Cosmetic-JCPT1012	2	JCPT1012HD/DC
	09640004	Decal, Cosmetic-JCPT1212	2	JCPT1212HD/DC
	09640005	Decal, Cosmetic-JCPT1412	2	JCPT1412HD/DC
	09640072	Decal, Cosmetic-JCPT1612B	2	JCPT1612HDB/DCB
	09640074	Decal, Cosmetic-JCPT1612S	2	JCPT1612HDS/DCS
20	09410005	Decal, Danger-Do not alter or disable limit switch	1	
21	09310004	Decal, Instructions-Emergency lower	1	
22	09410003	Decal, Warning-Inspected and operation properly	1	

Decals

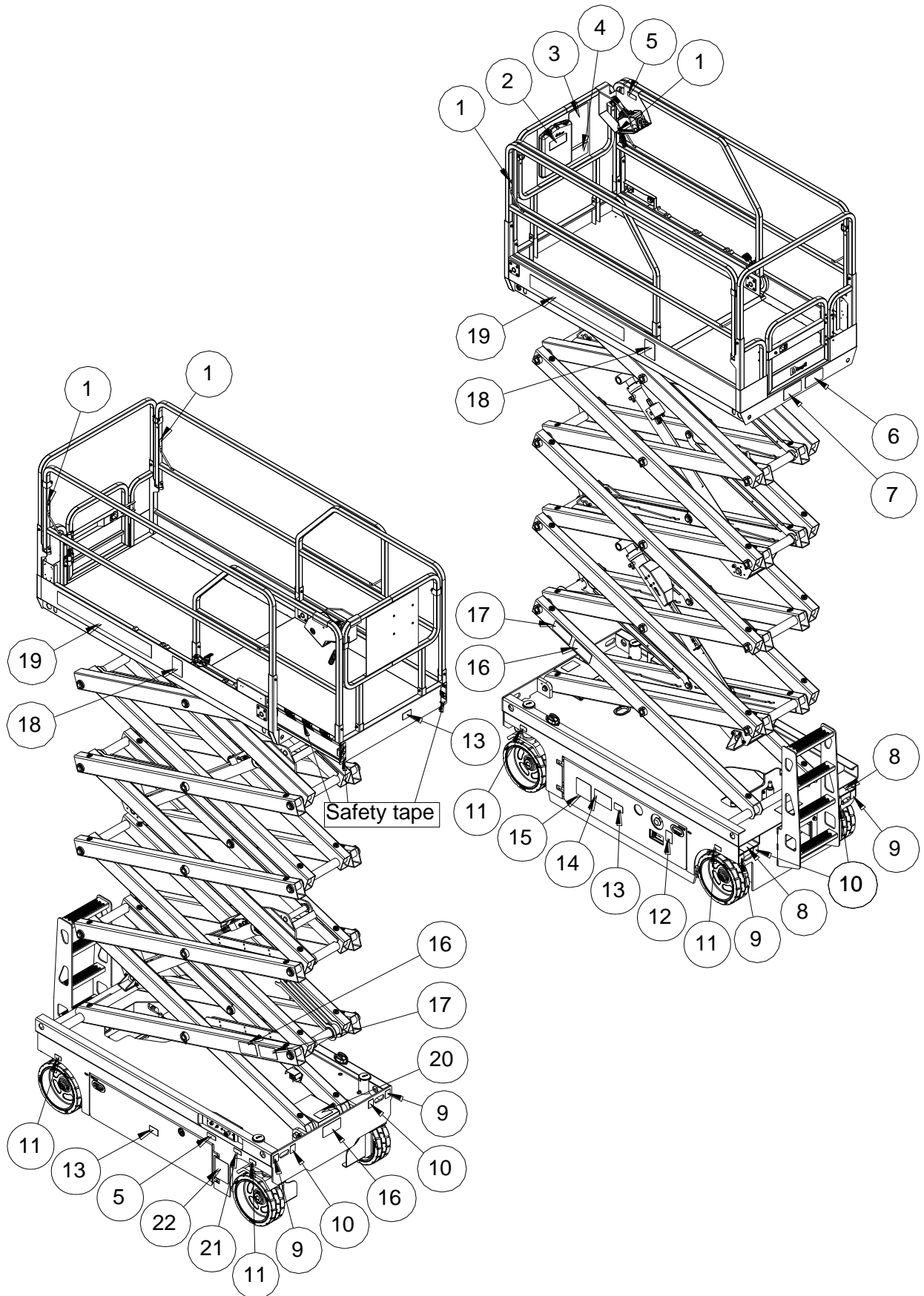

Decals

① 09440011



② 09340001



③ 09440001



④ 09440003



⑤ 09340003

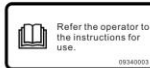

⑥ 09440014

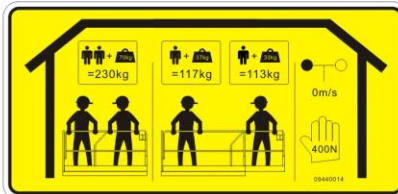

⑥ 09440017

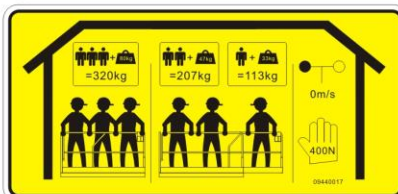

⑥ 09440038

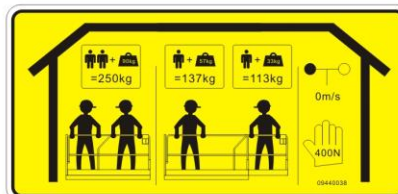

⑥ 09440013

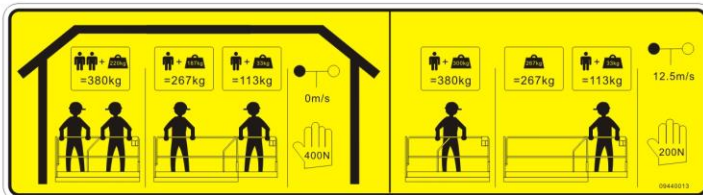

⑦ 09440005



⑥ 09440015

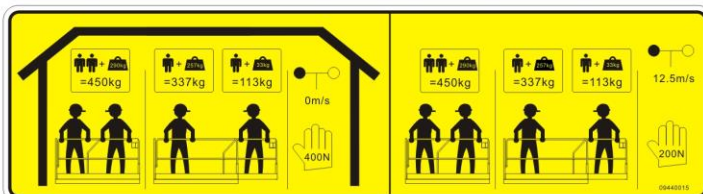

⑧ 09310001

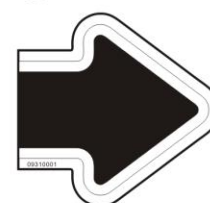

⑥ 09440016

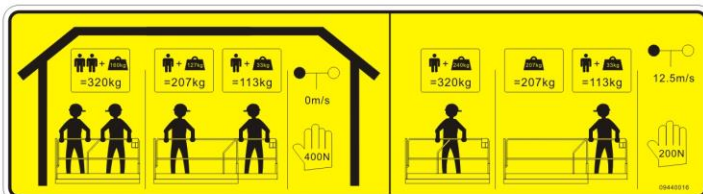

⑨ 09310003 ⑩ 09310002



Decals

11 09310008



11 09310014



12 09310006

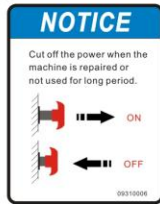

14 09410129



11 09310010



11 09310016



11 09310012



11 09310018



13 09540001



15 09410001



16 09430003



20 09410005



17 09430001



19 09640001

JCPT0808

19 09640002

JCPT1008

18 09440009



18 09440007

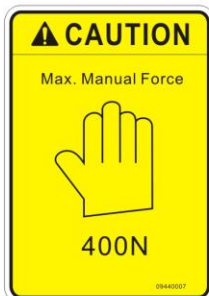

19 09640003

JCPT1012

19 09640004

JCPT1212

22 09410003



21 09310004



19 09640005

JCPT1412

19 09640072

JCPT1612B

19 09640074

JCPT1612S

Specifications

Model: JCPT0808HD

Height, working maximum	8 m	Maximum hydraulic pressure (functions)	240 bar
Height, platform maximum	6 m	System voltage	24 V
Height, stowed maximum Rails up	2.23 m	Tire size	Φ381×127 mm
Height, stowed maximum Rails folded	1.87 m	Airborne noise emissions	<70 dB
Width	0.83 m	Maximum sound level at normal operating workstations (A-weighted)	
Length, platform retracted	2.48 m	Vibration value does not exceed 2.5m/s ²	
Length, platform extended	3.38 m	Maximum slope rating, Stowed position	25%
Platform dimensions Platform length × width	2.27×0.81 m	Maximum side slope rating, Stowed position	25%
Platform extension length	0.9 m	Note: Slope rating is subject to ground conditions and adequate traction.	
Maximum load capacity	380 kg	Maximum working slope	X-1.5°, Y-3°
Maximum wind speed	12.5 m/s	Drive speeds	
Wheelbase	1.87 m	Stowed, maximum	3.5 km/h
Turning radius (outside)	2.10 m	Platform raised, maximum	0.8 km/h
Turning radius (inside)	0 m	Floor loading information	
Ground clearance	10 cm	Tire load, maximum	1000 kg
Ground clearance Pothole guards deployed	1.9 cm	Tire contact pressure	11.1 kg/cm ² 1086.9 kPa
Weight (See Serial Label)		Occupied floor pressure	1339 kg/m ² 13.1 kPa
Machine weights vary with option configurations		Note: Floor loading information is approximate and does not incorporate different option configurations. It should be used only with adequate safety factors.	
Controls	Proportional		
AC outlet in platform	Standard		

Continuous improvement of our products is a DINGLI policy. Product specifications are subject to change without notice or obligation.

Specifications**Model: JCPT1008HD**

Height, working maximum	10 m	Maximum hydraulic pressure (functions)	240 bar
Height, platform maximum	8 m	System voltage	24 V
Height, stowed maximum Rails up	2.36 m	Tire size	Φ381×127 mm
Height, stowed maximum Rails folded	2.00 m	Airborne noise emissions	<70 dB
Width	0.83 m	Maximum sound level at normal operating workstations (A-weighted)	
Length, platform retracted	2.48 m	Vibration value does not exceed 2.5m/s ²	
Length, platform extended	3.38 m	Maximum slope rating, Stowed position	25%
Platform dimensions Platform length × width	2.27×0.81 m	Maximum side slope rating, Stowed position	25%
Platform extension length	0.9 m	Note: Slope rating is subject to ground conditions and adequate traction.	
Maximum load capacity	230 kg	Maximum working slope	X-1.5°, Y-3°
Maximum wind speed	0 m/s	Drive speeds	
Wheelbase	1.87 m	Stowed, maximum	3.5 km/h
Turning radius (outside)	2.1 m	Platform raised, maximum	0.8 km/h
Turning radius (inside)	0 m	Floor loading information	
Ground clearance	10 cm	Tire load, maximum	960 kg
Ground clearance Pothole guards deployed	1.9 cm	Tire contact pressure	10.7 kg/cm ² 1045 kPa
Weight (See Serial Label)		Occupied floor pressure	1287.4 kg/m ² 12.6 kPa
Machine weights vary with option configurations		Note: Floor loading information is approximate and does not incorporate different option configurations. It should be used only with adequate safety factors.	
Controls	Proportional		
AC outlet in platform	Standard		

Continuous improvement of our products is a DINGLI policy. Product specifications are subject to change without notice or obligation.

Specifications

Model: JCPT1012HD

Height, working maximum	10 m	Maximum hydraulic pressure (functions)	240 bar
Height, platform maximum	8 m	System voltage	24 V
Height, stowed maximum Rails up	2.36 m	Tire size	Φ381×127 mm
Height, stowed maximum Rails folded	1.83 m	Airborne noise emissions	<70 dB
Width	1.15 m	Maximum sound level at normal operating workstations (A-weighted)	
Length, platform retracted	2.48 m	Vibration value does not exceed 2.5m/s ²	
Length, platform extended	3.38 m	Maximum slope rating, Stowed position	25%
Platform dimensions Platform length × width	2.27×1.12 m	Maximum side slope rating, Stowed position	25%
Platform extension length	0.9 m	Note: Slope rating is subject to ground conditions and adequate traction.	
Maximum load capacity	450 kg	Maximum working slope	X-1.5°, Y-3°
Maximum wind speed	12.5 m/s	Drive speeds	
Wheelbase	1.87 m	Stowed, maximum	3.5 km/h
Turning radius (outside)	2.2 m	Platform raised, maximum	0.8 km/h
Turning radius (inside)	0 m	Floor loading information	
Ground clearance	10 cm	Tire load, maximum	1240 kg
Ground clearance Pothole guards deployed	1.9 cm	Tire contact pressure	12.1 kg/cm ² 1182.6 kPa
Weight (See Serial Label)		Occupied floor pressure	1174.1 kg/m ² 11.5 kPa
Machine weights vary with option configurations		Note: Floor loading information is approximate and does not incorporate different option configurations. It should be used only with adequate safety factors.	
Controls	Proportional		
AC outlet in platform	Standard		

Continuous improvement of our products is a DINGLI policy. Product specifications are subject to change without notice or obligation.

Specifications**Model: JCPT1212HD**

Height, working maximum	12 m	Maximum hydraulic pressure (functions)	240 bar
Height, platform maximum	10 m	System voltage	24 V
Height, stowed maximum Rails up	2.49 m	Tire size	Φ381×127 mm
Height, stowed maximum Rails folded	1.96 m	Airborne noise emissions	<70 dB
Width	1.15 m	Maximum sound level at normal operating workstations (A-weighted)	
Length, platform retracted	2.48 m	Vibration value does not exceed 2.5m/s ²	
Length, platform extended	3.38 m	Maximum slope rating, Stowed position	25%
Platform dimensions Platform length × width	2.27×1.12 m	Maximum side slope rating, Stowed position	25%
Platform extension length	0.9 m	Note: Slope rating is subject to ground conditions and adequate traction.	
Maximum load capacity	320 kg	Maximum working slope	X-1.5°, Y-3°
Maximum wind speed	12.5 m/s	Drive speeds	
Wheelbase	1.87 m	Stowed, maximum	3.5 km/h
Turning radius (outside)	2.2 m	Platform raised, maximum	0.8 km/h
Turning radius (inside)	0 m	Floor loading information	
Ground clearance	10 cm	Tire load, maximum	1310 kg
Ground clearance Pothole guards deployed	1.9 cm	Tire contact pressure	12.9 kg/cm ² 1259.7 kPa
Weight (See Serial Label)		Occupied floor pressure	1250.7 kg/m ² 12.3 kPa
Machine weights vary with option configurations		Note: Floor loading information is approximate and does not incorporate different option configurations. It should be used only with adequate safety factors.	
Controls	Proportional		
AC outlet in platform	Standard		

Continuous improvement of our products is a DINGLI policy. Product specifications are subject to change without notice or obligation.

Specifications

Model: JCPT1412HD

Height, working maximum	13.8 m	Maximum hydraulic pressure (functions)	240 bar
Height, platform maximum	11.8 m	System voltage	24 V
Height, stowed maximum Rails up	2.62 m	Tire size	Φ381×127 mm
Height, stowed maximum Rails folded	2.09 m	Airborne noise emissions	<70 dB
Width	1.19 m	Maximum sound level at normal operating workstations (A-weighted)	
Length, platform retracted	2.48 m	Vibration value does not exceed 2.5m/s ²	
Length, platform extended	3.38 m	Maximum slope rating, Stowed position	25%
Platform dimensions Platform length × width	2.27×1.12 m	Maximum side slope rating, Stowed position	25%
Platform extension length	0.9 m	Note: Slope rating is subject to ground conditions and adequate traction.	
Maximum load capacity	320 kg	Maximum working slope	X-1.5°, Y-3°
Maximum wind speed	0 m/s	Drive speeds	
Wheelbase	1.87 m	Stowed, maximum	3.5 km/h
Turning radius (outside)	2.2 m	Platform raised, maximum	0.8 km/h
Turning radius (inside)	0 m	Floor loading information	
Ground clearance	10 cm	Tire load, maximum	1280 kg
Ground clearance Pothole guards deployed	1.9 cm	Tire contact pressure	11.1 kg/cm ² 1083.7 kPa
Weight (See Serial Label)		Occupied floor pressure	1169.8 kg/m ² 11.5 kPa
Machine weights vary with option configurations		Note: Floor loading information is approximate and does not incorporate different option configurations. It should be used only with adequate safety factors.	
Controls	Proportional		
AC outlet in platform	Standard		

Continuous improvement of our products is a DINGLI policy. Product specifications are subject to change without notice or obligation.

Specifications**Model: JCPT1612HDB**

Height, working maximum	15.7 m	Maximum hydraulic pressure (functions)	240 bar
Height, platform maximum	13.7 m	System voltage	24 V
Height, stowed maximum Rails up	2.62 m	Tire size	Φ381×127 mm
Height, stowed maximum Rails folded	2.09 m	Airborne noise emissions	<70 dB
Width	1.25 m	Maximum sound level at normal operating workstations (A-weighted)	
Length, platform retracted	2.84 m	Vibration value does not exceed 2.5m/s ²	
Length, platform extended	3.74 m	Maximum slope rating, Stowed position	25%
Platform dimensions Platform length × width	2.64×1.12 m	Maximum side slope rating, Stowed position	25%
Platform extension length	0.9 m	Note: Slope rating is subject to ground conditions and adequate traction.	
Maximum load capacity	250 kg	Maximum working slope	X-1.5°, Y-3°
Maximum wind speed	0 m/s	Drive speeds	
Wheelbase	2.22 m	Stowed, maximum	3.5 km/h
Turning radius (outside)	2.65 m	Platform raised, maximum	0.8 km/h
Turning radius (inside)	0 m	Floor loading information	
Ground clearance	10 cm	Tire load, maximum	1350 kg
Ground clearance Pothole guards deployed	1.9 cm	Tire contact pressure	11.7 kg/cm ² 1142 kPa
Weight (See Serial Label)		Occupied floor pressure	1013.1 kg/m ² 9.9 kPa
Machine weights vary with option configurations		Note: Floor loading information is approximate and does not incorporate different option configurations. It should be used only with adequate safety factors.	
Controls	Proportional		
AC outlet in platform	Standard		

Continuous improvement of our products is a DINGLI policy. Product specifications are subject to change without notice or obligation.

Specifications

Model: JCPT1612HDS

Height, working maximum	15.7 m	Maximum hydraulic pressure (functions)	240 bar
Height, platform maximum	13.7 m	System voltage	24 V
Height, stowed maximum Rails up	2.75 m	Tire size	Φ381×127 mm
Height, stowed maximum Rails folded	2.22 m	Airborne noise emissions	<70 dB
Width	1.19 m	Maximum sound level at normal operating workstations (A-weighted)	
Length, platform retracted	2.48 m	Vibration value does not exceed 2.5m/s ²	
Length, platform extended	3.38 m	Maximum slope rating, Stowed position	25%
Platform dimensions Platform length × width	2.27×1.12 m	Maximum side slope rating, Stowed position	25%
Platform extension length	0.9 m	Note: Slope rating is subject to ground conditions and adequate traction.	
Maximum load capacity	250 kg	Maximum working slope	X-1.5°, Y-3°
Maximum wind speed	0 m/s	Drive speeds	
Wheelbase	1.87 m	Stowed, maximum	3.5 km/h
Turning radius (outside)	2.20 m	Platform raised, maximum	0.8 km/h
Turning radius (inside)	0 m	Floor loading information	
Ground clearance	10 cm	Tire load, maximum	1350 kg
Ground clearance Pothole guards deployed	1.9 cm	Tire contact pressure	11.7 kg/cm ² 1142 kPa
Weight (See Serial Label)		Occupied floor pressure	1013.1 kg/m ² 9.9 kPa
Machine weights vary with option configurations		Note: Floor loading information is approximate and does not incorporate different option configurations. It should be used only with adequate safety factors.	
Controls	Proportional		
AC outlet in platform	Standard		

Continuous improvement of our products is a DINGLI policy. Product specifications are subject to change without notice or obligation.

Specifications**Model: JCPT0808DC**

Height, working maximum	8 m	Maximum hydraulic pressure (functions)	240 bar
Height, platform maximum	6 m	System voltage	24 V
Height, stowed maximum Rails up	2.23 m	Tire size	Φ381×127 mm
Height, stowed maximum Rails folded	1.87 m	Airborne noise emissions	<70 dB
Width	0.83 m	Maximum sound level at normal operating workstations (A-weighted)	
Length, platform retracted	2.48 m	Vibration value does not exceed 2.5m/s ²	
Length, platform extended	3.38 m	Maximum slope rating, Stowed position	25%
Platform dimensions Platform length × width	2.27×0.81 m	Maximum side slope rating, Stowed position	25%
Platform extension length	0.9 m	Note: Slope rating is subject to ground conditions and adequate traction.	
Maximum load capacity	380 kg	Maximum working slope	X-1.5°, Y-3°
Maximum wind speed	12.5 m/s	Drive speeds	
Wheelbase	1.87 m	Stowed, maximum	4.0 km/h
Turning radius (outside)	2.1 m	Platform raised, maximum	0.8 km/h
Turning radius (inside)	0 m	Floor loading information	
Ground clearance	10 cm	Tire load, maximum	1000 kg
Ground clearance Pothole guards deployed	1.9 cm	Tire contact pressure	11.3 kg/cm ² 1104.6 kPa
Weight (See Serial Label)		Occupied floor pressure	1360.7 kg/m ² 13.3 kPa
Machine weights vary with option configurations		Note: Floor loading information is approximate and does not incorporate different option configurations. It should be used only with adequate safety factors.	
Controls	Proportional		
AC outlet in platform	Standard		

Continuous improvement of our products is a DINGLI policy. Product specifications are subject to change without notice or obligation.

Specifications

Model: JCPT1008DC

Height, working maximum	10 m	Maximum hydraulic pressure (functions)	240 bar
Height, platform maximum	8 m	System voltage	24 V
Height, stowed maximum Rails up	2.36 m	Tire size	Φ381×127 mm
Height, stowed maximum Rails folded	2.00 m	Airborne noise emissions	<70 dB
Width	0.83 m	Maximum sound level at normal operating workstations (A-weighted)	
Length, platform retracted	2.48 m	Vibration value does not exceed 2.5m/s ²	
Length, platform extended	3.38 m	Maximum slope rating, Stowed position	25%
Platform dimensions Platform length × width	2.27×0.81 m	Maximum side slope rating, Stowed position	25%
Platform extension length	0.9 m	Note: Slope rating is subject to ground conditions and adequate traction.	
Maximum load capacity	230 kg	Maximum working slope	X-1.5°, Y-3°
Maximum wind speed	0 m/s	Drive speeds	
Wheelbase	1.87 m	Stowed, maximum	4.0 km/h
Turning radius (outside)	2.1 m	Platform raised, maximum	0.8 km/h
Turning radius (inside)	0 m	Floor loading information	
Ground clearance	10 cm	Tire load, maximum	960 kg
Ground clearance Pothole guards deployed	1.9 cm	Tire contact pressure	10.8 kg/cm ² 1062.7 kPa
Weight (See Serial Label)		Occupied floor pressure	1309.1 kg/m ² 12.8 kPa
Machine weights vary with option configurations		Note: Floor loading information is approximate and does not incorporate different option configurations. It should be used only with adequate safety factors.	
Controls	Proportional		
AC outlet in platform	Standard		

Continuous improvement of our products is a DINGLI policy. Product specifications are subject to change without notice or obligation.

Specifications**Model: JCPT1012DC**

Height, working maximum	10 m	Maximum hydraulic pressure (functions)	240 bar
Height, platform maximum	8 m	System voltage	24 V
Height, stowed maximum Rails up	2.36 m	Tire size	Φ381×127 mm
Height, stowed maximum Rails folded	1.83 m	Airborne noise emissions	<70 dB
Width	1.15 m	Maximum sound level at normal operating workstations (A-weighted)	
Length, platform retracted	2.48 m	Vibration value does not exceed 2.5m/s ²	
Length, platform extended	3.38 m	Maximum slope rating, Stowed position	25%
Platform dimensions Platform length × width	2.27×1.12 m	Maximum side slope rating, Stowed position	25%
Platform extension length	0.9 m	Note: Slope rating is subject to ground conditions and adequate traction.	
Maximum load capacity	450 kg	Maximum working slope	X-1.5°, Y-3°
Maximum wind speed	12.5 m/s	Drive speeds	
Wheelbase	1.87 m	Stowed, maximum	4.0 km/h
Turning radius (outside)	2.2 m	Platform raised, maximum	0.8 km/h
Turning radius (inside)	0 m	Floor loading information	
Ground clearance	10 cm	Tire load, maximum	1240 kg
Ground clearance Pothole guards deployed	1.9 cm	Tire contact pressure	12.2 kg/cm ² 1198 kPa
Weight (See Serial Label)		Occupied floor pressure	1189.4 kg/m ² 11.7 kPa
Machine weights vary with option configurations		Note: Floor loading information is approximate and does not incorporate different option configurations. It should be used only with adequate safety factors.	
Controls	Proportional		
AC outlet in platform	Standard		

Continuous improvement of our products is a DINGLI policy. Product specifications are subject to change without notice or obligation.

Specifications

Model: JCPT1212DC

Height, working maximum	12 m	Maximum hydraulic pressure (functions)	240 bar
Height, platform maximum	10 m	System voltage	24 V
Height, stowed maximum Rails up	2.49 m	Tire size	Φ381×127 mm
Height, stowed maximum Rails folded	1.96 m	Airborne noise emissions	<70 dB
Width	1.15 m	Maximum sound level at normal operating workstations (A-weighted)	
Length, platform retracted	2.48 m	Vibration value does not exceed 2.5m/s ²	
Length, platform extended	3.38 m	Maximum slope rating, Stowed position	25%
Platform dimensions Platform length × width	2.27×1.12 m	Maximum side slope rating, Stowed position	25%
Platform extension length	0.9 m	Note: Slope rating is subject to ground conditions and adequate traction.	
Maximum load capacity	320 kg	Maximum working slope	X-1.5°, Y-3°
Maximum wind speed	12.5 m/s	Drive speeds	
Wheelbase	1.87 m	Stowed, maximum	4.0 km/h
Turning radius (outside)	2.2 m	Platform raised, maximum	0.8 km/h
Turning radius (inside)	0 m	Floor loading information	
Ground clearance	10 cm	Tire load, maximum	1310 kg
Ground clearance Pothole guards deployed	1.9 cm	Tire contact pressure	12.9 kg/cm ² 1267.4 kPa
Weight (See Serial Label)		Occupied floor pressure	1258.4 kg/m ² 12.3 kPa
Machine weights vary with option configurations		Note: Floor loading information is approximate and does not incorporate different option configurations. It should be used only with adequate safety factors.	
Controls	Proportional		
AC outlet in platform	Standard		

Continuous improvement of our products is a DINGLI policy. Product specifications are subject to change without notice or obligation.

Specifications**Model: JCPT1412DC**

Height, working maximum	13.8 m	Maximum hydraulic pressure (functions)	240 bar
Height, platform maximum	11.8 m	System voltage	24 V
Height, stowed maximum Rails up	2.62 m	Tire size	Φ381×127 mm
Height, stowed maximum Rails folded	2.09 m	Airborne noise emissions	<70 dB
Width	1.19 m	Maximum sound level at normal operating workstations (A-weighted)	
Length, platform retracted	2.48 m	Vibration value does not exceed 2.5m/s ²	
Length, platform extended	3.38 m	Maximum slope rating, Stowed position	25%
Platform dimensions Platform length × width	2.27×1.12 m	Maximum side slope rating, Stowed position	25%
Platform extension length	0.9 m	Note: Slope rating is subject to ground conditions and adequate traction.	
Maximum load capacity	320 kg	Maximum working slope	X-1.5°, Y-3°
Maximum wind speed	0 m/s	Drive speeds	
Wheelbase	1.87 m	Stowed, maximum	4.0 km/h
Turning radius (outside)	2.2 m	Platform raised, maximum	0.8 km/h
Turning radius (inside)	0 m	Floor loading information	
Ground clearance	10 cm	Tire load, maximum	1280 kg
Ground clearance Pothole guards deployed	1.9 cm	Tire contact pressure	11.2 kg/cm ² 1097.5 kPa
Weight (See Serial Label)		Occupied floor pressure	1184.6 kg/m ² 11.6 kPa
Machine weights vary with option configurations		Note: Floor loading information is approximate and does not incorporate different option configurations. It should be used only with adequate safety factors.	
Controls	Proportional		
AC outlet in platform	Standard		

Continuous improvement of our products is a DINGLI policy. Product specifications are subject to change without notice or obligation.

Specifications

Model: JCPT1612DCB

Height, working maximum	15.7 m	Maximum hydraulic pressure (functions)	240 bar
Height, platform maximum	13.7 m	System voltage	24 V
Height, stowed maximum Rails up	2.62 m	Tire size	Φ381×127 mm
Height, stowed maximum Rails folded	2.09 m	Airborne noise emissions	<70 dB
Width	1.25 m	Maximum sound level at normal operating workstations (A-weighted)	
Length, platform retracted	2.84 m	Vibration value does not exceed 2.5m/s ²	
Length, platform extended	3.74 m	Maximum slope rating, Stowed position	25%
Platform dimensions Platform length × width	2.64×1.12 m	Maximum side slope rating, Stowed position	25%
Platform extension length	0.9 m	Note: Slope rating is subject to ground conditions and adequate traction.	
Maximum load capacity	250 kg	Maximum working slope	X-1.5°, Y-3°
Maximum wind speed	0 m/s	Drive speeds	
Wheelbase	2.22 m	Stowed, maximum	4.0 km/h
Turning radius (outside)	2.65 m	Platform raised, maximum	0.8 km/h
Turning radius (inside)	0 m	Floor loading information	
Ground clearance	10 cm	Tire load, maximum	1350 kg
Ground clearance Pothole guards deployed	1.9 cm	Tire contact pressure	11.8 kg/cm ² 1159.2 kPa
Weight (See Serial Label)		Occupied floor pressure	1028.4 kg/m ² 10.1 kPa
Machine weights vary with option configurations		Note: Floor loading information is approximate and does not incorporate different option configurations. It should be used only with adequate safety factors.	
Controls	Proportional		
AC outlet in platform	Standard		

Continuous improvement of our products is a DINGLI policy. Product specifications are subject to change without notice or obligation.

Specifications**Model: JCPT1612DCS**

Height, working maximum	15.7 m	Maximum hydraulic pressure (functions)	240 bar
Height, platform maximum	13.7 m	System voltage	24 V
Height, stowed maximum Rails up	2.75 m	Tire size	Φ381×127 mm
Height, stowed maximum Rails folded	2.22 m	Airborne noise emissions	<70 dB
Width	1.19 m	Maximum sound level at normal operating workstations (A-weighted)	
Length, platform retracted	2.48 m	Vibration value does not exceed 2.5m/s ²	
Length, platform extended	3.38 m	Maximum slope rating, Stowed position	25%
Platform dimensions Platform length × width	2.27×1.12 m	Maximum side slope rating, Stowed position	25%
Platform extension length	0.9 m	Note: Slope rating is subject to ground conditions and adequate traction.	
Maximum load capacity	250 kg	Maximum working slope	X-1.5°, Y-3°
Maximum wind speed	0 m/s	Drive speeds	
Wheelbase	1.87 m	Stowed, maximum	4.0 km/h
Turning radius (outside)	2.20 m	Platform raised, maximum	0.8 km/h
Turning radius (inside)	0 m	Floor loading information	
Ground clearance	10 cm	Tire load, maximum	1350 kg
Ground clearance Pothole guards deployed	1.9 cm	Tire contact pressure	11.7 kg/cm ² 1142 kPa
Weight (See Serial Label)		Occupied floor pressure	1013.1 kg/m ² 9.9 kPa
Machine weights vary with option configurations		Note: Floor loading information is approximate and does not incorporate different option configurations. It should be used only with adequate safety factors.	
Controls	Proportional		
AC outlet in platform	Standard		

Continuous improvement of our products is a DINGLI policy. Product specifications are subject to change without notice or obligation.

Specifications

Battery Specifications

JCPT0808DC, JCPT0808HD, JCPT1008DC, JCPT1008HD, JCPT1012DC, JCPT1012HD	standard	JCPT1412DC, JCPT1412HD, JCPT1612DCB, JCPT1612HDB, JCPT1612DCS, JCPT1612HDS	standard
Voltage	6VDC	Voltage	6VDC
Type	6TB170	Type	6TB220
Quantity	4	Quantity	4
Battery capacity, maximum	170Ah	Battery capacity, maximum	220Ah
Maintenance-free	Yes	Maintenance-free	Yes
JCPT0808DC, JCPT0808HD, JCPT1008DC, JCPT1008HD, JCPT1012DC, JCPT1012HD	optional	JCPT1412DC, JCPT1412HD, JCPT1612DCB, JCPT1612HDB, JCPT1612DCS, JCPT1612HDS	optional
Voltage	6VDC	Voltage	12VDC
Type	T-105 Plus	Type	TBX ² 12-100
Quantity	4	Quantity	4
Battery capacity, maximum	225Ah	Battery capacity, maximum	100Ah
Maintenance-free	No	Maintenance-free	Yes
JCPT1212DC, JCPT1212HD	standard	JCPT1412DC, JCPT1412HD, JCPT1612DCB, JCPT1612HDB, JCPT1612DCS, JCPT1612HDS	optional
Voltage	12VDC	Voltage	12VDC
Type	TBX ² 12-100	Type	T-1275 Plus
Quantity	4	Quantity	4
Battery capacity, maximum	100Ah	Battery capacity, maximum	150Ah
Maintenance-free	Yes	Maintenance-free	No
JCPT1212DC, JCPT1212HD	optional		
Voltage	6VDC		
Type	T-125 Plus		
Quantity	4		
Battery capacity, maximum	240Ah		
Maintenance-free	No		

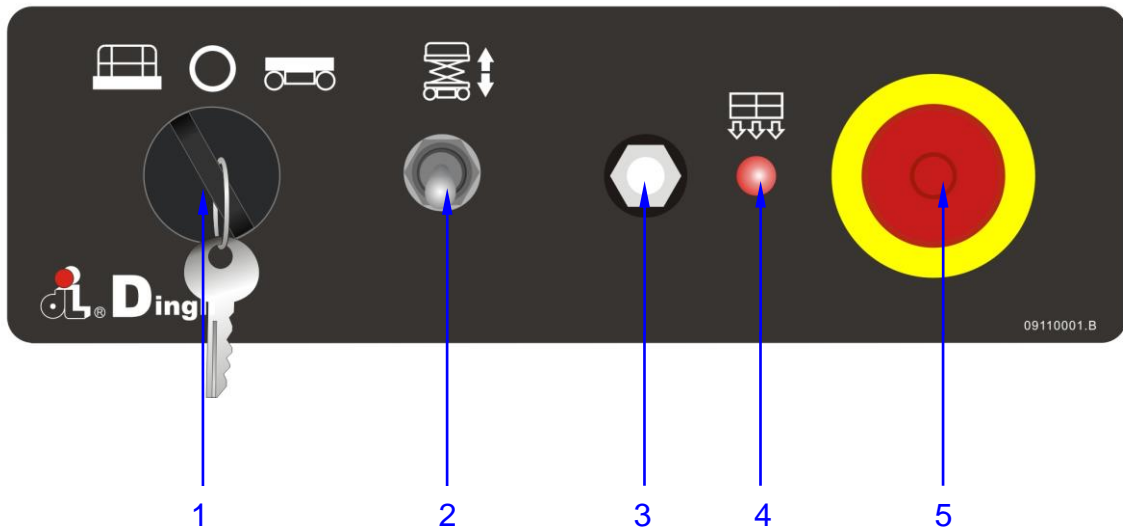
Control Panel**Ground Control Panel****1 Key switch**

Turn the key switch to the platform position and the platform controls will operate. Turn the key switch to the off position and the machine will be off. Turn the key switch to the base position and the ground controls will operate.

2 Platform up / down switch

Move the switch up and the platform will raise. Move the switch down and the platform will lower.

3 Circuit breaker

When the current was overloaded, the circuit breaker will cut off the circuit.

4 Overload indicator light

Light on indicates when overloaded.

5 Red Emergency Stop button

Push in the red Emergency Stop button to the off position to stop all functions.
Pull out the red Emergency Stop button to the on position to operate the machine.

Control Panel

Platform Control Panel

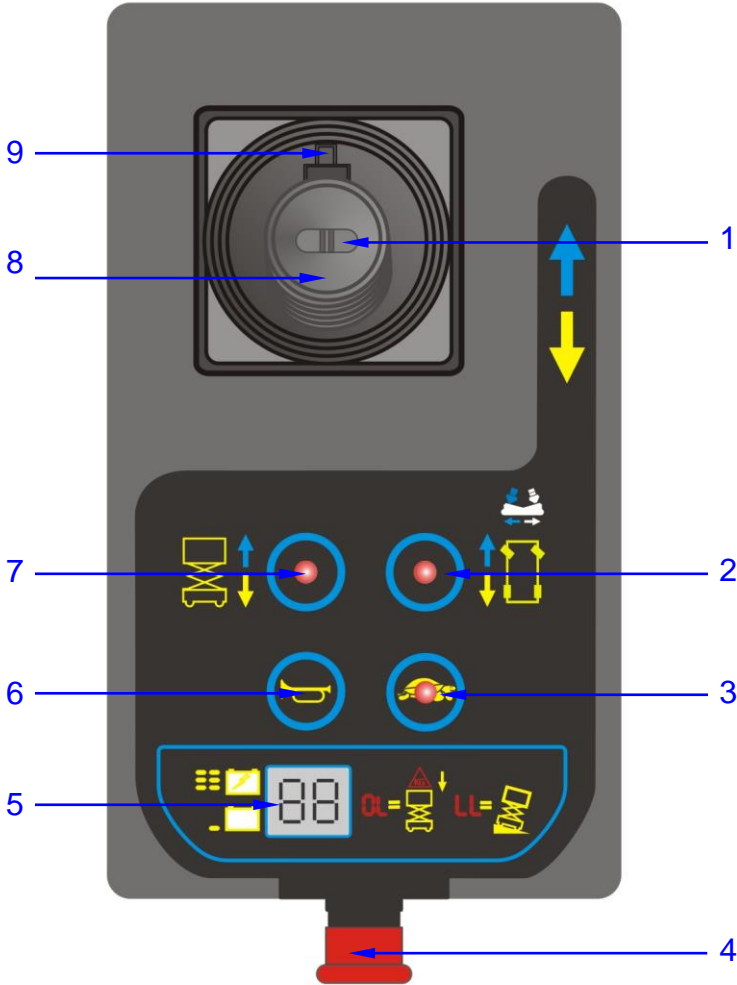

- 1 Thumb rocker switch
- 2 Drive function select button
- 3 Drive speed button
- 4 Red Emergency Stop button
- 5 LED readout screen
- 6 Horn button
- 7 Lift function select button
- 8 Proportional control handle
- 9 Function enable switch

Control Panel

Platform Control Panel

- 1 Thumb rocker switch
Press the thumb rocker switch in either direction to activate steer function.
- 2 Drive function select button
Press this button to activate the drive function.
- 3 Drive speed button
Press this button to activate the slow or fast drive function.
- 4 Red Emergency Stop button
Push in the red Emergency Stop button to the off position to stop all functions. Pull out the red Emergency Stop button to the on position to operate the machine.
- 5 LED readout screen
Diagnostic readout and battery charge indicator.
- 6 Horn Button
Push the horn button and the horn will sound. Release the horn button and the horn will stop.
- 7 Lift function select button
Press this button to activate the lift function.
- 8 Proportional control handle
Lift function: Press and hold the function enable switch to enable the lift function on the platform control handle. Move the control handle in the direction indicated by the blue arrow and the platform will raise. Move the control handle in the direction indicated by the yellow arrow and the platform will lower. The descent alarm should sound while the platform is lowering.
Drive function: Press and hold the function enable switch to enable the drive function on the platform control handle. Move the control handle in the direction indicated by the blue arrow on the control panel and the machine will move in the direction that the blue arrow points. Move the control handle in the direction indicated by the yellow arrow on the control panel and the machine will move in the direction that the yellow arrow points.
- 9 Function enable switch
Press and hold the function enable switch to enable the drive/lift function.

Pre-operation Inspection



Do Not Operate Unless:

You learn and practice the principles of safe machine operation contained in this operator's manual.

- 1 Avoid hazardous situations.
- 2 **Always perform a pre-operation inspection.**

Know and understand the pre-operation inspection before going on to the next section.

- 3 Inspect the workplace.
- 4 Always perform function tests prior to use.
- 5 Only use the machine as it was intended.

Fundamentals

It is the responsibility of the operator to perform a pre-operation inspection and routine maintenance.

The pre-operation inspection is a visual inspection performed by the operator prior to each work shift. The inspection is designed to discover if anything is apparently wrong with a machine before the operator performs the function tests.

The pre-operation inspection also serves to determine if routine maintenance procedures are required. Only routine maintenance items specified in this manual may be performed by the operator.

Refer to the list on the next page and check each of the items.

If damage or any unauthorized variation from factory delivered condition is discovered, the machine must be tagged and removed from service.

Repairs to the machine may only be made by a qualified service technician, according to the manufacturer's specifications. After repairs are completed, the operator must perform a pre-operation inspection again before going on to the function tests.

Scheduled maintenance inspections shall be performed by qualified service technicians, according to the manufacturer's specifications and the requirements listed in this manual.

Pre-operation Inspection

Pre-operation Inspection

- Be sure that the operator's manual are complete, legible and in the storage container located in the platform.
- Be sure that all decals are legible and in place. See Decals section.
- Check for hydraulic oil leaks and proper oil level. Add oil if needed. See Maintenance section.
- Check for battery fluid leaks and proper fluid level. Add distilled water if needed. See Maintenance section.

Check the following components or areas for damage, improperly installed or missing parts and unauthorized modifications:

- Electrical components, wiring and electrical cables
- Hydraulic hoses, fittings, cylinders and manifolds
- Battery pack and connections
- Drive motors
- Wear pads
- Tires and wheels
- Ground strap
- Limit switches, alarms and horn
- Nuts, bolts and other fasteners
- Platform overload components
- Platform entry gate
- Beacon (if equipped)
- Safety arm
- Platform extension(s)
- Scissor pins and retaining fasteners
- Platform control joystick
- Brake release components
- Pothole guard

Check entire machine for:

- Cracks in welds or structural components
- Dents or damage to machine
- Be sure that all structural and other critical components are present and all associated fasteners and pins are in place and properly tightened
- Be sure side rails are installed and rail pins and bolts are fastened.
- Be sure that the chassis trays are closed and latched and the batteries are properly connected.

Note: If the platform must be raised to inspect the machine, make sure the safety arm is in place. See Operating Instructions section.

Workplace Inspection



Do Not Operate Unless:

You learn and practice the principles of safe machine operation contained in this operator's manual.

- 1 Avoid hazardous situations.
- 2 Always perform a pre-operation inspection.
- 3 Inspect the workplace.**

Know and understand the workplace inspection before going on to the next section.

- 4 Always perform function tests prior to use.
- 5 Only use the machine as it was intended.

Fundamentals

The workplace inspection helps the operator determine if the workplace is suitable for safe machine operation. It should be performed by the operator prior to moving the machine to the workplace.

It is the operator's responsibility to read and remember the workplace hazards, then watch for and avoid them while moving, setting up and operating the machine.

Workplace Inspection

Be aware of and avoid the following hazardous situations:

- Drop-offs or holes
- Bumps, floor obstructions or debris
- Sloped surfaces
- Unstable or slippery surfaces
- Overhead obstructions and high voltage conductors
- Hazardous locations
- Inadequate surface support to withstand all load forces imposed by the machine
- Wind and weather conditions
- The presence of unauthorized personnel
- Other possible unsafe conditions

Function Tests



Do Not Operate Unless:

You learn and practice the principles of safe machine operation contained in this operator's manual.

- 1 Avoid hazardous situations.
- 2 Always perform a pre-operation inspection.
- 3 Inspect the workplace.
- 4 **Always perform function tests prior to use.**

Know and understand the function tests before going on to the next section.

- 5 Only use the machine as it was intended.

Fundamentals

The function tests are designed to discover any malfunctions before the machine is put into service.

The operator must follow the step-by-step instructions to test all machine functions.

A malfunctioning machine must never be used. If malfunctions are discovered, the machine must be tagged and removed from service.

Repairs to the machine may only be made by a qualified service technician, according to the manufacturer's specifications.

After repairs are completed, the operator must perform a pre-operation inspection and function tests again before putting the machine into service.

Function Tests

- 1 Select a test area that is firm, level and free of obstruction.
- 2 Be sure the battery pack is connected.
- 3 Pull out the main power switch to "on" position.

At the Ground Controls

- 4 Pull out the platform and ground red Emergency Stop button to the on position.

- 5 Turn the key switch to ground control.
- 6 Observe the LED readout screen on the platform controls.

- ⊙ Result: The LED should look like the picture at right.



- 7 Observe the LED readout screen on the ECU window.

- ⊙ Result: The LED should look like the picture at right.



Test Emergency Stop

- 8 Push in the ground red Emergency Stop button to the off position.

- ⊙ Result: No functions should operate.

- 9 Pull out the red Emergency Stop button to the on position.

Test Up/Down Functions

A buzzer with different sound frequency is controlled in central system. The descent alarm sounds at 60 beeps per minute. The descent delay alarm sounds at 120 beeps per minute. The alarm that goes off when the pothole guards have not deployed sounds at 180 beeps per minute. The alarm that goes off when the machine is not level sounds at 180 beeps per minute. An optional automotive-style horn is also available.

- 10 Turn the key switch to off or platform position.
- 11 Move up and hold the platform up / down switch.

- ⊙ Result: No function should operate.

- 12 Turn the key switch to ground control position.

- 13 Move up and hold the platform up / down switch.

- ⊙ Result: The platform should raise.

- 14 Move down and hold the platform up / down switch.

- ⊙ Result: The platform should lower. The descent alarm should sound while the platform is lowering. The platform stop at the height is approximately 2m from the ground. The descent delay alarm will sound.

Note: Be sure the area below the platform is clear of personnel and obstructions before continuing.

- 15 Move down and hold the platform up / down switch.

- ⊙ Result: The platform should lower to end. The descent delay alarm should sound while the platform is lowering.

Test the Emergency Lowering

- 16 Activate the up function and raise the platform approximately 60 cm.

- 17 Pull the emergency lowering knob located on the ground controls side of the machine.

- ⊙ Result: The platform should lower. The descent alarm will not sound.

- 18 Turn the key switch to platform control.

Function Tests

At the Platform Controls

Test Emergency Stop

- 19 Push in the platform red Emergency Stop button to the off position.
- ⊙ Result: No functions should operate.
- 20 Pull out the red Emergency Stop button to the on position.
- ⊙ Result: The LED indicator light should come on.

Test the Horn

- 21 Push the horn button.
- ⊙ Result: The horn should sound.

Test Function Enable and Up/Down Functions

- 22 Do not hold the function enable switch on the control handle.
- 23 Slowly move the control handle in the direction indicated by the blue up arrow, then in the direction indicated by the yellow down arrow.
- ⊙ Result: No functions should operate.
- 24 Press the lift function select button.
- 25 Press and hold the function enable switch on the control handle.
- 26 Slowly move the control handle in the direction indicated by the blue up arrow.
- ⊙ Result: The platform should raise. The pothole guards should deploy.
- 27 Release the control handle.
- ⊙ Result: The platform should stop raising.
- 28 Press and hold the function enable switch. Slowly move the control handle in the direction indicated by the yellow down arrow.
- ⊙ Result: The platform should lower. The

descent alarm should sound while the platform is lowering.

Test the Steering

Note: When performing the steer and drive function tests, stand in the platform facing the steer end of the machine.

- 29 Press the drive function select button. The indicator light should turn on.
- 30 Press and hold the function enable switch on the control handle.
- 31 Depress the thumb rocker switch on top of the control handle in the direction identified by the blue left arrow on the control panel.
- ⊙ Result: The steer wheels should turn in the direction that the blue left arrow points on the control panel.
- 32 Depress the thumb rocker switch in the direction identified by the white right arrow on the control panel.
- ⊙ Result: The steer wheels should turn in the direction that the white right arrow points on the control panel.

Test Drive and Braking

- 33 Press the drive function select button. The indicator light should turn on.
- 34 Press and hold the function enable switch on the control handle.
- 35 Slowly move the control handle in the direction indicated by the blue up arrow on the control panel until the machine begins to move, then return the handle to the center position.
- ⊙ Result: The machine should move in the direction that the blue up arrow points on the control panel, then come to an abrupt stop.
- 36 Press and hold the function enable switch on the control handle.

Function Tests

- 37 Slowly move the control handle in the direction indicated by the yellow down arrow on the control panel until the machine begins to move, then return the handle to the center position.

- ⊙ Result: The machine should move in the direction that the yellow down arrow points on the control panel, then come to an abrupt stop.

Note: The brakes must be able to hold the machine on any slope it is able to climb.

Test Limited Drive Speed

- 38 Press and hold the function enable switch. Raise the platform approximately 2m from the ground.

- ⊙ Result: The pothole guards should deploy.

- 39 Press and hold the function enable switch on the control handle.

- 40 Slowly move the control handle to the full drive position.

- ⊙ Result: The maximum achievable drive speed with the platform raised should not exceed 22 cm/s.

- ⊘ Result: If the drive speed with the platform raised exceeds 22 cm/s, immediately tag and remove the machine from service.

Test the Tilt Sensor Operation

Note: Perform this test from the ground with the platform controller. Do not stand in the platform.

- 41 Fully lower the platform.
- 42 Place a 3.5×20cm or similar piece of wood under both wheels on one side and drive the machine up onto them.
- 43 Raise the platform approximately 2m from the ground.
- ⊙ Result: The platform should stop and the tilt alarm will sound at 180 beeps per minute.

The platform controls LED readout should display LL.

- 44 Press the drive function select button.

- 45 Press and hold the function enable switch on the control handle.

- 46 Move the control handle in the direction indicated by the blue up arrow, then move the control handle in the direction indicated by the yellow down arrow.

- ⊙ Result: The drive function should not work in either direction.

- 47 Lower the platform and drive the machine off the block.

Test the Pothole Guards

Note: The pothole guards should automatically deploy when the platform is raised. The pothole guards activate another limit switch which allows the machine to continue to function. If the pothole guards do not deploy, an alarm sounds and the machine will not drive and lift.

- 48 Raise the platform.

- ⊙ Result: When the platform is raised approximately 2m from the ground, the pothole guards should deploy.

- 49 Press on the pothole guards on one side, and then the other.

- ⊙ Result: The pothole guards should not move.

- 50 Lower the platform.

- ⊙ Result: The pothole guards should return to the stowed position.

- 51 Place a 3.5×20cm or similar piece of wood under a pothole guard. Raise the platform.

- ⊙ Result: When the platform is raised approximately 2m from the ground, the pothole alarm will sound at 180 beeps per minute, and the platform controls LED

Function Tests

screen readout should display 18.

- 52 Press the drive function select button.
- 53 Press and hold the function enable switch on the control handle.
- 54 Move the control handle in the direction indicated by the blue up arrow, and then move the control handle in the direction indicated by the yellow down arrow.
 - ⊙ Result: The drive function should not work in either direction.
- 55 Press and hold the function enable switch on the control handle.
- 56 Depress the thumb rocker switch on top of the control handle in the direction identified by the blue and white arrow on the control panel.
 - ⊙ Result: The steer function should not work in either direction.
- 57 Lower the platform and remove the 3.5×20cm wood block.

Operating Instructions



Do Not Operate Unless:

- You learn and practice the principles of safe machine operation contained in this operator's manual.
- 1 Avoid hazardous situations.
- 2 Always perform a pre-operation inspection.
- 3 Inspect the workplace.
- 4 Always perform function tests prior to use.
- 5 **Only use the machine as it was intended.**

Fundamentals

This machine is a self-propelled hydraulic lift equipped with a work platform on the scissor mechanism. Vibrations emitted by these machines are not hazardous to an operator in the work platform. The machine can be used to position personnel with their tools and supplies at position above ground level and can be used to reach work areas located above and over machinery or equipment.

A full and detailed implementation of EN ISO 13849-1/2 is correctly applied on our MEWP design. SISTEMA, a software tool for PL Calculation Tool, is also used to perform some relatively straightforward calculations on subsystem to determine the overall PL of the system. Reliability data, diagnostic coverage [DC], the system architecture [Category], common cause failure and, where relevant, requirements for software are used to assess the PL to comply with PLr of SRP/CS in Clause 5.11 of EN 280.

The Operating Instructions section provides instructions for each aspect of machine operation.

It is the operator's responsibility to follow all the safety rules and instructions in the operator's manual.

Using the machine for anything other than lifting personnel, along with their tools and materials, to an aerial work site is unsafe and dangerous.

Only trained and authorized personnel should be permitted to operate a machine. If more than one operator is expected to use a machine at different times in the same work shift, they must all be qualified operators and are all expected to follow all safety rules and instructions in the operator's manual. That means every new operator should perform a pre-operation inspection, function tests, and a workplace inspection before using the machine.

Operating Instructions

Emergency Stop

Push in the red Emergency Stop button to the off position at the ground controls or the platform controls to stop all machine functions.

Repair any function that operates when either red Emergency Stop button is pushed in.

Emergency Lowering

- 1 Pull the emergency lowering knob.

Operation from Ground

- 1 Be sure the battery pack is connected before operating the machine.
- 2 Turn the key switch to ground control.
- 3 Pull out the platform and ground red Emergency Stop button to the on position.

To Position Platform

- 1 Move the platform up/down switch according to the markings on the control panel.

Drive and steer functions are not available from the ground controls.

Operation from Platform

- 1 Be sure the battery pack is connected before operating the machine.
- 2 Turn the key switch to platform control.
- 3 Pull out the platform and ground red Emergency Stop button to the on position.

To Position Platform

- 1 Press the lift function select button.
- 2 Press and hold the function enable switch on the control handle.
- 3 Move the control handle according to the markings on the control panel.

To Steer

- 1 Press the drive function select button.
- 2 Press and hold the function enable switch on the control handle.
- 3 Turn the steer wheels with the thumb rocker switch located on the top of the control handle.

To Drive

- 1 Press the drive function select button.
- 2 Press and hold the function enable switch on the control handle.
- 3 Increase speed: Slowly move the control handle off center.

Decrease speed: Slowly move the control handle toward center.

Stop: Return the control handle to center or release the function enable switch.

Use the color-coded direction arrows on the platform controls to identify the direction the machine will travel.

Machine travel speed is restricted when the platform is raised.

Battery condition will affect machine performance. Machine drive speed and function speed will drop when the battery level indicator is flashing.

To reduce drive speed

The drive controls can operate in two different drive speed modes. When the drive speed button light is on, slow drive speed mode is active. When the button light is off, fast drive speed mode is active.

Press the drive speed button to select the desired drive speed.

▲ Driving on a slope

Determine the slope and side slope ratings for the machine and determine the slope grade.

Operating Instructions

JCPT0808, JCPT1012, JCPT1008, JCPT1212, JCPT1412, JCPT1612B, JCPT1612S maximum slope rating, stowed position 25%, maximum side slope rating, stowed position 25%.

Note: Slope rating is subject to ground conditions and adequate traction.

Press the drive speed button to the fast drive speed mode.

To determine the slope grade

Measure the slope with a digital inclinometer OR use the following procedure.

You will need:

Carpenter's level

Straight piece of wood, at least 1 m long

Tape measure

Lay the piece of wood on the slope.

At the downhill end, lay the level on the top edge of the piece of wood and lift the end until the piece of wood is level.

While holding the piece of wood level, measure the distance from the bottom of the piece of wood to the ground.

Divide the tape measure distance (rise) by the length of the piece of wood (run) and multiply by 100.

Example:

Run = 3.6 m

Rise = 0.3 m

$$0.3 \text{ m} \div 3.6 \text{ m} = 0.083 \times 100 = 8.3\%$$



If the slope exceeds the maximum slope or side slope rating, the machine must be winched or transported up or down the slope. See Transport and Lifting section.

Operation from Ground with Controller

Maintain safe distances between operator, machine and fixed objects.

Be aware of the direction the machine will travel when using the controller.

Battery Level Indicator



Use the LED readout screen to determine the battery level.

How to use the Safety Arm

- 1 Raise the platform until the distance of the two sets of scissor at least 0.5m.
- 2 Lift the safety arm, move it to the center of the scissor arm and rotate up to a vertical position.
- 3 Lift the upper safety arm, move it to the center of the scissor arm and rotate down to a vertical position. (for JCPT1412, JCPT1612B, JCPT1612S).
- 4 Lower the platform until the safety arm rests securely on the link. Keep clear of the safety arm when lowering the platform.

⚠ DANGER Engage all safety arms before performing maintenance or repair.

⚠ DANGER Don't engage the safety arm unless unload the platform.

Operating Instructions

How to Fold Down the Guardrails

The platform railing system consists of three fold down rail section for the extension deck and three sections for the main deck. All sections are held in place by four wire lock pins.

- 1 Fully lower the platform and retract the platform extension.
- 2 Remove the platform controls.
- 3 From inside the platform, remove the two front extension deck wire lock pins.
- 4 Fold down the front rail assembly. Keep hands clear of pinch points.
- 5 Replace the two removed pins back into each side rail bracket.
- 6 Fold down the extension platform left rail assembly. Keep hands clear of pinch points.
- 7 Fold down the extension platform right rail assembly. Keep hands clear of pinch points.
- 8 Carefully open the gate and move to the rear step or the ground.
- 9 From the rear step or from the ground, remove the left rear main deck wire lock pins.
- 10 Fold down the left rail assembly. Keep hands clear of pinch points.
- 11 Replace the removed pin back into rear rail bracket.
- 12 Remove the right rear main deck wire lock pins.
- 13 Fold down the right rail assembly. Keep hands clear of pinch points.
- 14 Replace the removed pin back into rear rail bracket.
- 15 Fold down the rear rail assembly. Keep hands free of pinch points.

How to Raise the Guardrails

Follow the fold down instructions but in reverse order.

To Extend and Retract Platform

- 1 Press the platform lock pin pedal on the extension deck by foot.
- 2 Push the platform extension guardrail to extend the platform to the desired position.

Do not stand on the platform extension while trying to extend it.

Operating Instructions

Error indicator readout



The LED readout screen displays fault codes that provide information about the machine operating status and about malfunctions. The fault codes listed in the following charts describe malfunctions and can aid in troubleshooting the machine by pinpointing the area or component affected.

List of Fault Codes

Display	Description	Lift Reaction
01	System initialization Fault	Disables All Motion
02	System communication Fault	Disables All Motion
03	Invalid option setting Fault	Disables All Motion
09	GPS communication Fault	Disables All Motion
12	Chassis Up/Down Switch ON at Power-up Fault	Disable Chassis Control
18	Pothole Guard Fault	Disable Lifting and Driving
31	Pressure Sensor Fault	Disables All Motion
32	Angle Sensor Fault	Disables All Motion
35	Pressure Sensor 2 Fault	Disables All Motion
36	Low Battery Alert	Warning Only
42	Platform Left Turn Switch ON at power-up Message	Warning Only
43	Platform Right Turn Switch ON at power-up Message	Warning Only
46	Platform Joystick Enable Switch ON at power-up Fault	Disable Platform Control
47	Platform Joystick not in neutral at power-up Message	Warning Only
52	Drive Forward Coil Fault	Disable Lifting and Driving
53	Drive Reverse Coil Fault	Disable Lifting and Driving
54	Lift Up Coil Fault	Disable Lifting and Driving
55	Lift Down Coil Fault	Disable Lifting and Driving
56	Right Turn Coil Fault	Disable Lifting and Driving
57	Left Turn Coil Fault	Disable Lifting and Driving
58	General Brake Coil Fault	Disable Lifting and Driving
59	Parallel Coil Fault	Disable Lifting and Driving
60	Motor Controller Fault	Controller Dependent
61	Motor Controller Current Sensor Fault	Controller Dependent
62	Motor Controller Hardware Failsafe Fault	Controller Dependent
63	Motor Controller Motor Output Fault	Controller Dependent

Operating Instructions

Display	Description	Lift Reaction
64	Motor Controller SRO Fault	Controller Dependent
65	Motor Controller Throttle Fault	Controller Dependent
66	Motor Controller Emergency Reverse Fault	Controller Dependent
67	Motor Controller HPD Fault	Controller Dependent
68	Low Voltage Fault	Disable All Motion
69	High Neutral Current Fault (ZAPI Only)	Disable All Motion
70	Steering Input Out of Range (ZAPI Only)	Disable All Motion
71	Motor Controller Main Contactor Fault	Disable Lifting and Driving
72	Motor Controller Over Voltage Fault	Controller Dependent
73	Motor Controller Thermal Cutback Fault	Controller Dependent
74	Motor Controller Motor Fault	Controller Dependent
75	Motor Controller Pump Motor Fault	Controller Dependent
76	Motor Controller Left Drive Motor Fault	Controller Dependent
77	Motor Controller Right Drive Motor Fault	Controller Dependent
78	Pump Motor Short Fault	Disable Lifting and Driving
79	Left Drive Motor Short Fault	Disable Lifting and Driving
80	Over 80% Load Warning	Warning Only
81	Right Drive Motor Short Fault	Disable Lifting and Driving
82	Left Brake Coil Fault	Disable Lifting and Driving
83	Right Brake Coil Fault	Disable Lifting and Driving
84	Motor Post Shorted	Disable Lifting and Driving
85	Brake Release Switch On	Warning Only
86	Brake Release Not Showed	Warning Only
87	Brake Release	Warning Only
89	Motor Field Open	Disable Lifting and Driving
90	Over 90% Load Warning	Warning Only
91	Left Motor Field Short	Disable Lifting and Driving
92	Right Motor Field Short	Disable Lifting and Driving
99	Over 99% Load Warning	Warning Only
OL	Overloaded Platform Fault	Disable All Motion
LL	Machine Tilted Beyond Safe Limits Fault	Disable Lifting and Driving

Operating Instructions

Troubleshooting Guide

Display	Description
01	System Initialization Fault: ECU may be malfunctioning, replace it.
02	System Communication Fault: Check communications cable connections and other wiring. If that does not resolve the problem, try replacing the PCU or ECU.
03	Invalid Option setting Fault: Set appropriate option for this lift.
09	GPS Communication Fault: Check communications cable connections and other wiring. If that does not resolve the problem, try replacing the GPS.
12	Chassis Toggle Switch ON at power-up Fault: Check the wires to the Toggle Switch or look for a stuck Toggle Switch.
18	Pothole Guard Fault: Check that the pothole guards are extended, check the pothole limit switches. Check wires to the switches, check the down limit switch and connections.
31	Pressure Sensor Fault: Check the wiring to the sensor and then the sensor itself. Also check to make sure that the correct option is properly selected (or not) for load sensing.
32	Angle Sensor Fault: Check the wiring to the sensor and then the sensor itself. Also check to make sure that the correct option is properly selected (or not) for load sensing
35	Pressure Sensor 2 Fault: Check the wiring to the sensor and then the sensor itself. Also check to make sure that the correct option is properly selected (or not) for load sensing.
36	Low Voltage Alert: Check battery voltage and charge batteries if necessary.
42	Platform Left Turn Switch ON at power-up Message: Ensure that nothing is holding the Joystick Toggle Switches down. If OK, consider replacing the Joystick or PCU.
43	Platform Right Turn Switch ON at power-up Message: Ensure that nothing is holding the Joystick Toggle Switches down. If OK, consider replacing the Joystick or PCU.
46	Platform Joystick Enable Switch ON at power-up Fault: Ensure that nothing is holding the Enable switch closed. Also check the neutral zone parameters. If OK, consider replacing the Joystick or PCU.
47	Platform Joystick not in neutral at power-up Message: Make sure that the Joystick is in the neutral (upright) position. Check the neutral zone parameter setting in Dingli Scissor Programmer. If it's OK, consider replacing the Joystick or the PCU.
52	Drive Forward Coil Fault: Check the connections to the Coil's terminals and make sure they are tight. If so, check the coil itself to see if it is open or shorted.
53	Drive Reverse Coil Fault: Check the connections to the Coil's terminals and make sure they are tight. If so, check the coil itself to see if it is open or shorted.
54	Lift Up Coil Fault: Check the connections to the Coil's terminals and make sure they are tight. If so, check the coil itself to see if it is open or shorted.

Operating Instructions

Display	Description
55	Lift Down Coil Fault: Check the connections to the Coil's terminals and make sure they are tight. If so, check the coil itself to see if it is open or shorted.
56	Right Turn Coil Fault: Check the connections to the Coil's terminals and make sure they are tight. If so, check the coil itself to see if it is open or shorted.
57	Left Turn Coil Fault: Check the connections to the Coil's terminals and make sure they are tight. If so, check the coil itself to see if it is open or shorted.
58	General Brake Coil Fault: Check the connections to the Coil's terminals and make sure they are tight. If so, check the coil itself to see if it is open or shorted.
59	Parallel Coil Fault: Check the connections to the Coil's terminals and make sure they are tight. If so, check the coil itself to see if it is open or shorted.
60	Motor Controller Fault: Cycle power. If still needed, try replacing the Motor Controller.
61	Motor Controller Current Sensor Fault: Drive or Lift Motor may be overheating. Let the lift cool down. If that does not help, cycle power to reset the Motor controller. If the problem persists, check the wiring and if OK, try replacing the Motor Controller.
62	Motor Controller Hardware Failsafe Fault: Cycle power. If that does not resolve the issue check for noise sources. If still needed, try replacing the Motor Controller.
63	Motor Controller Motor Output fault: Check wiring first then cycle power. If needed replace controller.
64	Motor Controller SRO Fault: Look at motor enable delay with the Dingli Scissor Programmer, it may be too short. Make sure other Motor Controller parameters are properly selected.
65	Motor Controller Throttle Fault: Check wiring. Make sure the correct throttle type is selected in the Motor Controller.
66	Motor Controller Emergency Reverse Fault: Ensure that the Emergency Reverse Check Parameter is off in the Motor Controller.
67	Motor Controller HPD Fault: Look at motor enable delay with the Dingli Scissor Programmer, it may be too short. Make sure other Motor Controller parameters are properly selected.
68	Low Voltage Fault: Check battery voltage and charge batteries if necessary. Check the battery connections and tighten or clean. Check the voltage to the ECU and PCU.
69	High Neutral Current: The MC is sensing current in the motors when there should not be. This could occur anytime the MC thinks the brakes are on and the motors are still turning. This message sometimes comes just before other faults but should be ignored in those cases.
70	Steering Input Out of Range: There is an inappropriate voltage at the steering input of the ZAPI motor controller. The ZAPI may need to be "trained" for the three steering voltages (on Differential Steered machines). Or the steering voltage from the ECU was at some point outside of the range that was recorded during the "training" session. Retrain the controller and/or check for fluctuating voltages due to loose wires, etc.

Operating Instructions

Display	Description
71	Motor Controller Main Contactor Fault: Check the connections to the main contactor. Replace the contactor if necessary. Replace the Motor Controller if necessary.
72	Motor Controller Over Voltage Fault: Check battery voltage and make sure the battery charger is not on. The cycle power to the lift. If that does not resolve the issue, try replacing the Motor Controller.
73	Motor Controller Thermal Cutback Fault: Drive or Lift Motor may be overheating. Let the lift cool down. If that does not help cycle power to reset the Motor controller. If that doesn't resolve the issue, replace the Motor Controller.
74	Motor Controller Motor Fault: Check connections to the motors. Cycle power to the lift and if that does not resolve the issue, replace the Motor Controller.
75	Motor Controller Pump Motor Fault: Check connections to the Pump Motor. Cycle power to the lift and if that does not resolve the issue, replace the Motor Controller.
76	Motor Controller Left Drive Motor Fault: Check connections to the motors. Cycle power to the lift and if that does not resolve the issue, replace the Motor Controller.
77	Motor Controller Right Drive Motor Fault: Check connections to the motors. Cycle power to the lift and if that does not resolve the issue, replace the Motor Controller.
78	Pump Motor Short Fault: Check connections to the pump motor. Cycle power to the lift and if that does not resolve the issue, replace the Motor Controller.
79	Left Drive Motor Short Fault: Check the Motor connections and make sure they are tight. Check the Motor for a short.
80	Over 80% Load Warning: Platform is getting close to its limit of weight. Consider not adding more load.
81	Right Drive Motor Short Fault: Check the Motor connections and make sure they are tight. Check the Motor for a short.
82	Left Brake Coil Fault: Check the connections to the Coil's terminals and make sure they are tight. If so, check the coil itself to see if it is open or shorted.
83	Right Brake Coil Fault: Check the connections to the Coil's terminals and make sure they are tight. If so, check the coil itself to see if it is open or shorted.
84	Motor Post shorted: Check the connections of the controller and motor. Make sure the wiring is not shorted.
85	Brake Release Switch On: Check the wires to brake release switch or look for a stuck switch.
86	Brake Release Not Stowed: Check if the platform is below down limit height. Check the down limit switch and connections.
87	Brake Release Need Switch On: Check the wires to brake release switch or look for a Stuck switch. Check the wires to the Toggle Switch or look for a stuck Toggle Switch.
89	Motor Field Open: The field voltage is different from 1/2 battery voltage. Check connections of the field wires or leakage to the vehicle frame.

Operating Instructions

Display	Description
90	Over 90% Load Warning: Platform is getting close to its limit of weight. Consider not adding more load.
91	Left Motor Field Short: Check connections of the field wires or leakage to the vehicle frame.
92	Right Motor Field Short: Check connections of the field wires or leakage to the vehicle frame.
99	Over 99% Load Warning: Platform has reached its limit of weight. Do not add more load.
OL	Overloaded Platform Fault: Remove the excess load immediately.
LL	Machine Tilted Beyond Safe Limits Fault: If the machine is tilted, find a way to make it level. If the machine is level, check the wiring to the tilt sensor and then the sensor itself.

For more information, please consult the appropriate Dingli Service Dept.

Operating Instructions



Battery and Charger Instructions

Observe and Obey:

- Do not use an external charger or booster battery.
- Charge the battery in a well-ventilated area.
- Use proper AC input voltage for charging as indicated on the charger.
- Use only a Dingli authorized battery and charger.
- Charge the battery as soon as receive the machine or after long distance transportation
- When the battery is stored for a long time, it needs to be charged regularly. Failure to charge in time may permanently damage the battery.

To Charge Battery

- 1 Be sure the batteries are connected before charging.
- 2 Open the battery compartment. The compartment should remain open for the entire charging cycle.

Maintenance - free battery

- 3 Connect the battery charger to a grounded AC circuit.
- 4 The charger will indicate when the battery is fully charged.

Standard Battery

- 5 Remove the battery vent caps and check the battery acid level. If necessary, add only enough distilled water to cover the plates. Do not overfill prior to the charge cycle.
- 6 Replace the battery vent caps.
- 7 Connect the battery charger to a grounded AC circuit.
- 8 The charger will indicate when the battery is fully charged.
- 9 Check the battery acid level when the charging cycle is complete. Replenish with distilled water to the bottom of the fill tube. Do not overfill.

Dry Battery Filling and Charging Instructions

- 1 Remove the battery vent caps and permanently remove the plastic seal from the battery vent openings.

Operating Instructions

- 2 Fill each cell with battery acid (electrolyte) until the level is sufficient to cover the plates.

Do not fill to maximum level until the battery charge cycle is complete. Overfilling can cause the battery acid to overflow during charging. Neutralize battery acid spills with baking soda and water.

- 3 Install the battery vent caps.
- 4 Charge the battery.
- 5 Check the battery acid level when the charging cycle is complete. Replenish with distilled water to the bottom of the fill tube. Do not overfill.

Note: In order to achieve an optimal service life, discharge of over 60% of the rated capacity should be avoided. Discharge of over 80% of the rated capacity is a deep discharge and is not permissible. These significantly reduce the service life of the battery. Only those discharge state indicators that have been approved by the battery manufacturer may be used.

Discharged batteries must be charged immediately and must not remain in discharged state. This also applies to batteries in a state of deep discharge. Otherwise, the service life of the battery will be significantly reduced. The battery may freeze when in discharged state

Charge the battery immediately when the machine displays "36" or "68" alarm code during work.

During the charging process, if temperatures are consistently higher than 40°C or lower than 15°C, stop charging to check whether the battery and charger are normal.

Transport and Lifting Instructions



Observe and Obey:

- ✓ Common sense and planning must be applied to control the movement of the machine when lifting it with a crane or forklift.
- ✓ Only qualified aerial lift operators should move the machine on or off the truck.
- ✓ The transport vehicle must be parked on a level surface.
- ✓ The transport vehicle must be secured to prevent rolling while the machine is being loaded.
- ✓ Be sure the vehicle capacity, loading surfaces and chains or straps are sufficient to withstand the machine weight. See the serial label for the machine weight.
- ✓ The machine must be on a level surface or secured before releasing the brakes.
- ✓ Do not allow the rails to fall when the snap pins are removed. Maintain a firm grasp on the rails when the rails are lowered.
- ✓ Do not drive the machine on a slope that exceeds the slope or side slope rating. See Driving on a Slope in the Operating Instructions section.
- ✓ If the slope of the transport vehicle bed exceeds the maximum slope rating, the machine must be loaded and unloaded using a winch as described.

Brake Release Operation

For the Hydraulic Motor Drive Model

- 1 Chock the wheels to prevent the machine from rolling.
- 2 Be sure the winch line is properly secured to the drive chassis tie points and the path is clear of all obstructions.
- 3 Push in the black brake release knob to open the brake valve.
- 4 Pump the red brake release pump knob.
- 5 If you want to close the brake release, just pull out the black brake release knob.

For the DC Motor Drive Model

- 1 Chock the wheels to prevent the machine from rolling.
- 2 **Pull out the platform and ground red Emergency Stop button to the on position.**
- 3 Move down and hold the platform up / down switch in ground control, meanwhile turn on the key switch to the "Ground" position. The brake will be released after Alarm alerts.
- 4 If you want to close the brake release, just turn off the key switch in "ground" position.

Towing the Hydraulic Drive Model is not recommended. If the machine must be towed, do not exceed 3.5 km/h.

Towing the DC Motor Drive Model is not recommended. If the machine must be towed, do not exceed 4.0 km/h.

Transport and Lifting Instructions

Securing to Truck or Trailer for Transit

Always chock the machine wheels in preparation for transport.

Retract and secure the extension deck(s).

Turn the key switch to the off position and remove the key before transporting.

Inspect the entire machine for loose or unsecured items.

Use the tie-down points on the chassis for anchoring down to the transport surface.

Use a minimum of four chains or straps.

Use chains or straps of ample load capacity.

If the railings have been folded down, secure them with straps before transporting.

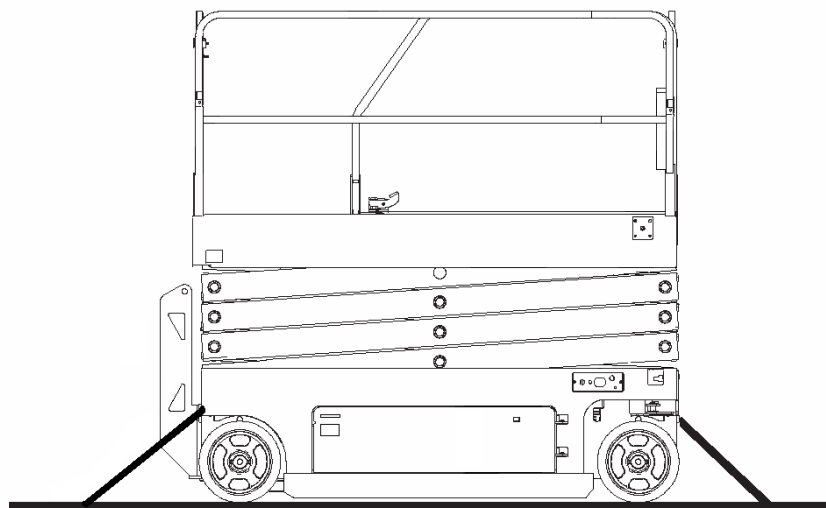
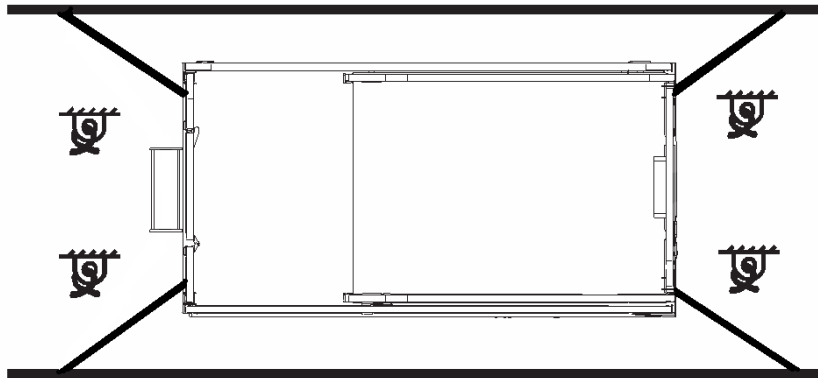

Transport and Lifting Instructions



Observe and Obey:

- Only qualified riggers should rig and lift the machine.
- Only qualified forklift operators should lift the machine with a forklift.
- Be sure the crane capacity, loading surfaces and straps or lines are sufficient to withstand the machine weight. See the serial plate for the machine weight.

Lifting the Machine with a Forklift

Be sure the extension deck, controls and component trays are secure. Remove all loose items on the machine.

Fully lower the platform. The platform must remain lowered during all loading and transport procedures.

Use the forklift pockets located on both sides of the ladder.

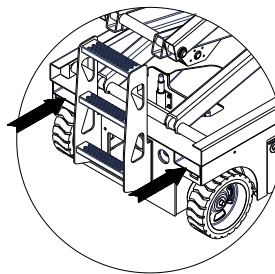

Position the forklift forks in position with the forklift pockets.

Drive forward to the full extent of the forks.

Raise the machine 15 cm and then tilt the forks back slightly to keep the machine secure.

Be sure the machine is level when lowering the forks.

NOTICE

Lifting the machine from the side can result in component damage.

Transport and Lifting Instructions

Lifting Instructions

Fully lower the platform. Be sure the extension decks, controls and covers are secure.

Remove all loose items on the machine.

Determine the center of gravity of your machine using the table and the picture on this page.

Attach the rigging only to the designated lifting points on the machine. There are two lifting points on each end of the machine.

Adjust the rigging to prevent damage to the machine and to keep the machine level.

Center of gravity

Model	X Axis	Y Axis
JCPT0808HD JCPT0808DC	90.5 cm	56.5cm
JCPT1008HD JCPT1008DC	80.6cm	57.6cm
JCPT1012HD JCPT1012DC	89cm	64.4cm
JCPT1212HD JCPT1212DC	83cm	68.2cm
JCPT1412HD JCPT1412DC	83cm	72.1cm
JCPT1612HDB JCPT1612DCB	98cm	70.5cm
JCPT1612HDS JCPT1612DCS	93.7cm	80.2cm

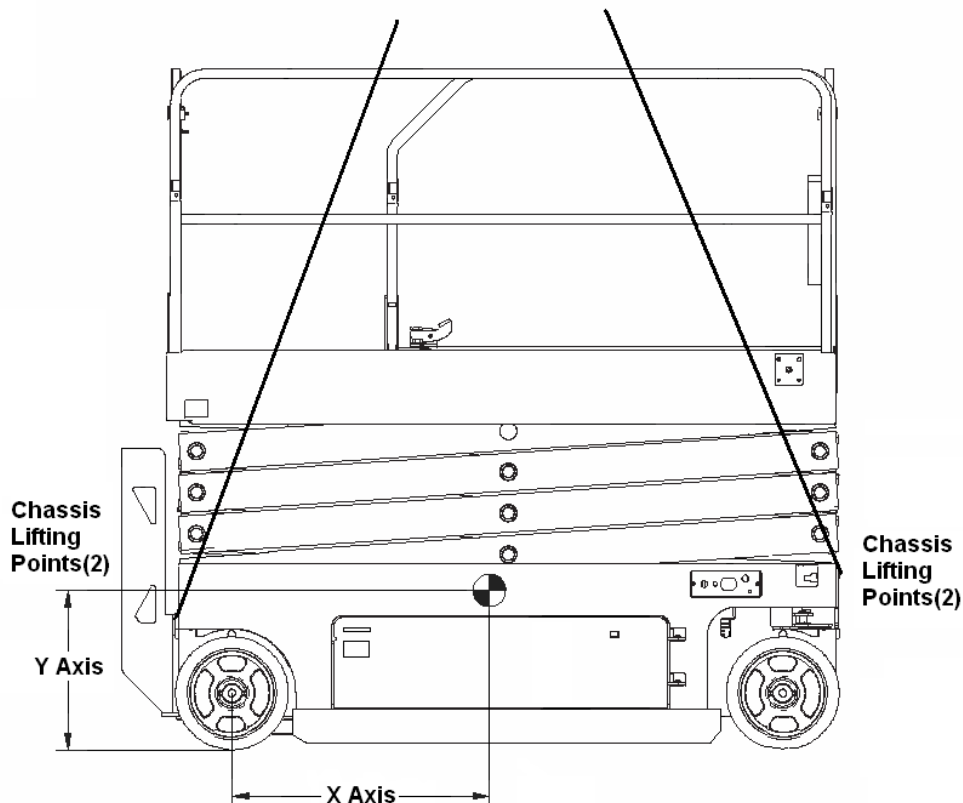

Storage



Observe and Obey:

The storage of the machine shall be as follows, Incorrect storage may affect the performance and service life of the machine

- 1 The machine should be stored indoor coeditor and the ground should be firm and level. If be stored in outdoor condition the machine should be covered to prevent the water and dust.
- 2 Ensure the machine have been cleaned and the functional before stop to the storage. Repair an maintain it if necessary.
- 3 Stop the machine in suitable position so as the drive or move the machines conveniently.

Rust protection

- 1 Before the machine is stored into the storage. Inspecting the paint before the machine is stored into the storage repaint the machine partly all completely against the damage.
- 2 For moving parts grease can be applied to prevent rust, such as bearings, joints and sliding rails

⚠ CAUTION The machine be stored long time cannot be used to service until it has been inspected and maintained according to the daily check procedure.

How to store the batteries

- 1 When storing the machine for a long time (one month to six months) be sure to turn off the main power switch, key switch and emergency stop switch, fully charge. In order to ensure that these batteries stay ready for operation, the following charging procedures must be applied:

The machine or check the voltage of each battery on the machine once a month to ensure that the voltage of battery is not lower than 25.2V, otherwise please charge the machine immediately.
- 2 When storing the machine for a long time (half a year or more), should be fully charged state. The batteries should be removed from the machine. keep the batteries being clean and ensure nothing being placed on the top of batteries. The batteries connection should be disconnection as bellow. Disconnect the wire from the negative pole first the disconnect the wires from the positive pole. The batteries should be connected as bellow: First connect the positive power wires with the positive pole then connect the negative cable line to the negative pole finally. In order to ensure that these batteries stay ready for operation, the batteries should be charged one time in every quarter.
- 3 The following conditions can result in battery serious injuries:
 - The battery was not charged in time when the machine displays "36" or "68" alarm code during work.
 - Leave the Key Switch, Emergency Switch or Power Switch on.
 - Forget to charge the battery regularly when storing the machine for a long time.

Maintenance



Observe and Obey:

- Only routine maintenance items specified in this manual shall be performed by the operator.
- Scheduled maintenance inspections shall be completed by qualified service technicians, according to the manufacturer's specifications and the requirements specified in this manual.

Maintenance Symbols Legend

NOTICE The following symbols have been used in this manual to help communicate the intent of the instructions. When one or more of the symbols appear at the beginning of a maintenance procedure, it conveys the meaning below.



Indicates that tools will be required to perform this procedure.



Indicates that new parts will be required to perform this procedure.



Indicates that dealer service will be required to perform this procedure.

Pre-delivery Preparation Report

The pre-delivery preparation report contains checklists for each type of scheduled inspection.

Make copies of the Pre-delivery Preparation report to use for each inspection. Store completed forms as required.

Maintenance Schedule

There are five types of maintenance inspections that must be performed according to a schedule— daily, quarterly, semi-annually, annually, and two year. The Scheduled Maintenance Procedures Section and the Maintenance Inspection Report have been divided into five subsections—A, B, C, D, and E. Use the following chart to determine which group(s) of procedures are required to perform a scheduled inspection.

Inspection	Checklist
Daily or every 8 hours	A
Quarterly or every 250 hours	A+B
Semi-annually or every 500 hours	A+B+C
Annually or every 1000 hours	A+B+C+D
Two year or every 2000 hours	A+B+C+D+E

Maintenance Inspection Report

The maintenance inspection report contains checklists for each type of scheduled inspection.

Make copies of the Maintenance Inspection Report to use for each inspection. Maintain completed forms for a minimum of 4 years or in compliance with your employer, jobsite and governmental regulations and requirements.

Maintenance

Pre-delivery Preparation Report

Fundamentals

It is the responsibility of the dealer to perform the Pre-delivery Preparation.

The Pre-delivery Preparation is performed prior to each delivery. The inspection is designed to discover if anything is apparently wrong with a machine before it is put into service.

A damaged or modified machine must never be used. If damage or any variation from factory delivered condition is discovered, the machine must be tagged and removed from service.

Repairs to the machine may only be made by a qualified service technician, according to the manufacturer's specifications.

Scheduled maintenance inspections shall be performed by qualified service technicians, according to the manufacturer's specifications and the requirements listed in this manual.

Instructions

Use the operator's manual on your machine.

The Pre-delivery Preparation consists of completing the Pre-operation Inspection, the Maintenance items and the Function Tests.

Use this form to record the results. Place a check in the appropriate box after each part is completed. Follow the instructions in the operator's manual.

If any inspection receives an N, remove the machine from service, repair and re-inspect it. After repair, place a check in the R box.

Legend

Y = yes, completed

N = no, unable to complete

R = repaired

Comments

Pre-Delivery Preparation	Y	N	R
Pre-operation inspection completed			
Maintenance items completed			
Function tests completed			

Model

Serial number

Date

Machine owner

Inspected by (print)

Inspector signature

Inspector title

Inspector company

Maintenance

Maintenance Inspection Report

Model
Serial number
Date
Hour meter
Machine owner
Inspected by (print)
Inspector signature
Inspector title
Inspector company
Instructions
<ul style="list-style-type: none"> • Make copies of this report to use for each inspection. • Select the appropriate checklist(s) for the type of inspection to be performed.
<input type="checkbox"/> Daily or 8 hours Inspection: A
<input type="checkbox"/> Quarterly or 250 hours Inspection: A+B
<input type="checkbox"/> Semi-annually or 500 hours Inspection: A+B+C
<input type="checkbox"/> Annually or 1000 hours Inspection: A+B+C+D
<input type="checkbox"/> Two year or 2000 hours Inspection: A+B+C+D+E
<ul style="list-style-type: none"> • Place a check in the appropriate box after each inspection procedure is completed. • Use the step-by-step procedures in this section to learn how to perform these inspections. • If any inspection receives an "N", tag and remove the machine from service, repair and re-inspect it. After repair, place a check in the "R" box.
Legend
Y = yes, acceptable
N = no, remove from service
R = repaired

Checklist A	Y	N	R
A-1 Inspect the manuals and decals			
A-2 Pre-operation inspection			
A-3 Check the Batteries			
A-4 Check the Hydraulic Oil Level			
A-5 Function tests			
Perform after 40 hours:			
A-6 30 day service			
Checklist B	Y	N	R
B-1 Batteries			
B-2 Electrical wiring			
B-3 Tires and wheels			
B-4 Emergency stop			
B-5 Key switch			
B-6 Horn (if equipped)			
B-7 Drive brakes			
B-8 Drive speed - stowed			
B-9 Drive speed - raised			
B-10 Drive speed - slow			
B-11 Hydraulic oil analysis			
B-12 Tank venting system			
B-13 Latch components			
B-14 Test the down limit switch, the pothole limit switches and the level Sensor			
B-15 Test the up limit switches			
Checklist C	Y	N	R
C-1 Platform overload (if equipped)			
C-2 Breather cap - models with optional oil			
Checklist D	Y	N	R
D-1 Scissor arm wear pads			
D-2 Hydraulic filter			
Checklist E	Y	N	R
E-1 Hydraulic oil			

Maintenance

Checklist A Procedures

A-1

Inspect the Manuals and Decals

Maintaining the operator's manual in good condition is essential to safe machine operation. Manuals are included with each machine and should be stored in the container provided in the platform. An illegible or missing manual will not provide safety and operational information necessary for a safe operating condition.

In addition, maintaining all of the safety and instructional decals in good condition is mandatory for safe machine operation. Decals alert operators and personnel to the many possible hazards associated with using this machine. They also provide users with operation and maintenance information. An illegible decal will fail to alert personnel of a procedure or hazard and could result in unsafe operating conditions.

- 1 Check to make sure that the operator's manual is present and complete in the storage container on the platform.
- 2 Examine the pages of manual to be sure that they are legible and in good condition.

☉ Result: The operator's manual is appropriate for the machine and the manual are legible and in good condition.

☒ Result: The operator's manual is not appropriate for the machine or the manual is not in good condition or is illegible. Remove the machine from service until the manual is replaced.

- 3 Open the operator's manual to the decals inspection section. Carefully and thoroughly inspect all decals on the machine for legibility and damage.

☉ Result: The machine is equipped with all required decals, and all decals are legible and in good condition.

☒ Result: The machine is not equipped with all required decals, or one or more decals are illegible or in poor condition. Remove the machine from service until the decals are replaced.

- 4 Always return the manual to the storage container after use.

Note: Contact your authorized DINGLI distributor or DINGLI machinery if replacement manuals or decals are needed.

A-2**Perform Pre-operation Inspection**

Completing a Pre-operation Inspection is essential to safe machine operation. The Pre-operation Inspection is a visual inspection performed by the operator prior to each work shift. The inspection is designed to discover if anything is apparently wrong with a machine before the operator performs the function tests. The Pre-operation Inspection also serves to determine if routine maintenance procedures are required.

Complete information to perform this procedure is available in the appropriate operator's manual. Refer to the operator's manual on your machine.

A-3**Check the Batteries**

Proper battery condition is essential to good machine performance and operational safety. Improper fluid levels or damaged cables and connections can result in component damage and hazardous conditions.

⚠ WARNING Electrocutation hazard.

Contact with hot or live circuits may result in death or serious injury. Remove all rings, watches and other jewelry.

⚠ WARNING Bodily injury hazard.

Batteries contain acid. Avoid spilling or contacting battery acid. Neutralize battery acid spills with baking soda and water.

- 1 Put on protective clothing and eye wear.
- 2 Be sure that the battery cable connections are tight and free of corrosion.
- 3 Be sure that the battery hold-down bars are secure.
- 4 Remove the battery vent caps.
- 5 Check the battery acid level. If needed, replenish with distilled water to the bottom of the battery fill tube. Do not overfill.
- 6 Install the vent caps.

Maintenance

A-4

Check the Hydraulic Oil Level



Maintaining the hydraulic oil at the proper level is essential to machine operation. Improper hydraulic oil levels can damage hydraulic components. Daily checks allow the inspector to identify changes in oil level that might indicate the presence of hydraulic system problems.

NOTICE

Perform this procedure with the platform in the stowed position.

- 1 Visually inspect the sight of hydraulic oil level from the side of the hydraulic oil tank.

⊙ Result: The hydraulic oil level should be at the mark of the fuel tank. (Refer to the following table).

Model	Scale line (L)
JCPT0808HD/DC	15
JCPT1008HD/DC	
JCPT1012HD/DC	
JCPT1212HD/DC	17.5
JCPT1412HD/DC	
JCPT1612HDB/DCB	19
JCPT1612HDS/DCS	

- 2 Add oil if necessary. Do not overfill.

NOTICE

Original Hydraulic oil specifications: L-HV46

Customers shall choose the appropriate hydraulic oil according to the ambient temperature used.

Example: L-HV32 or L-HV68

A-5

Perform Function Tests

Completing the function tests is essential to safe machine operation. Function tests are designed to discover any malfunctions before the machine is put into service. A malfunctioning machine must never be used. If malfunctions are discovered, the machine must be tagged and removed from service.

Complete information to perform this procedure is available in the appropriate operator's manual. Refer to the operator's manual on your machine.

A-6**Perform 30 Day Service**

The 30 day maintenance procedure is a one time procedure to be performed after the first 30 days or 40 hours of usage. After this interval, refer to the maintenance tables for continued scheduled maintenance.

Perform the following maintenance procedures:

- B-3 Inspect the Tires, Wheels and Castle Nut Torque
- D-2 Replace the Hydraulic Tank Return Filter Element

Maintenance

Checklist B Procedures

B-1

Inspect the Batteries



DINGLI requires that this procedure be performed every 250 hours or quarterly, whichever comes first.

Proper battery condition is essential to good machine performance and operational safety. Improper fluid levels or damaged cables and connections can result in component damage and hazardous conditions.

⚠ WARNING Electrocutation / burn hazard. Contact with electrically charged circuits could result in death or serious injury. Remove all rings, watches and other jewelry.

⚠ WARNING Bodily injury hazard. Batteries contain acid. Avoid spilling or contacting battery acid. Neutralize battery acid spills with baking soda and water.

- 1 Put on protective clothing and eye wear.
- 2 Release the battery pack latch and rotate the battery pack out and away from the chassis.
- 3 Be sure that the battery cable connections are free of corrosion.

Note: Adding terminal protectors and a corrosion preventative sealant will help eliminate corrosion on the battery terminals and cables.

- 4 Be sure that the battery retainers and cable connections are tight.
- 5 Fully charge the batteries. Allow the batteries to rest 24 hours before performing this procedure to allow the battery cells to equalize.

Models without maintenance-free or sealed batteries:

- 6 Remove the battery vent caps and check the specific gravity of each battery cell with a hydrometer. Note the results.
- 7 Check the ambient air temperature and adjust the specific gravity reading for each cell as follows:
 - Add 0.004 to the reading of each cell for every 5.5° C above 26.7° C.
 - Subtract 0.004 from the reading of each cell for every 5.5° C below 26.7° C.
- ⊙ Result: All battery cells display an adjusted specific gravity of 1.277 or higher. The battery is fully charged. Proceed to step 11.
- ⊗ Result: One or more battery cells display a specific gravity of 1.217 or below. Proceed to step 8.
- 8 Perform an equalizing charge OR fully charge the batteries and allow the batteries to rest at least 6 hours.
- 9 Remove the battery vent caps and check the specific gravity of each battery cell with a hydrometer. Note the results.
- 10 Check the ambient air temperature and adjust the specific gravity reading for each cell as follows:
 - Add 0.004 to the reading of each cell for every 5.5° C above 26.7° C.
 - Subtract 0.004 from the reading of each cell for every 5.5° C below 26.7° C.
- ⊙ Result: All battery cells display a specific gravity of 1.277 or greater. The battery is

Maintenance

fully charged. Proceed to step 11.

- ⊗ Result: The difference in specific gravity readings between cells is greater than 0.1
OR the specific gravity of one or more cells is less than 1.177. Replace the battery.
- 11 Check the battery acid level. If needed, replenish with distilled water to 3 mm below the bottom of the battery fill tube. Do not overfill.
- 12 Install the vent caps and neutralize any electrolyte that may have spilled.

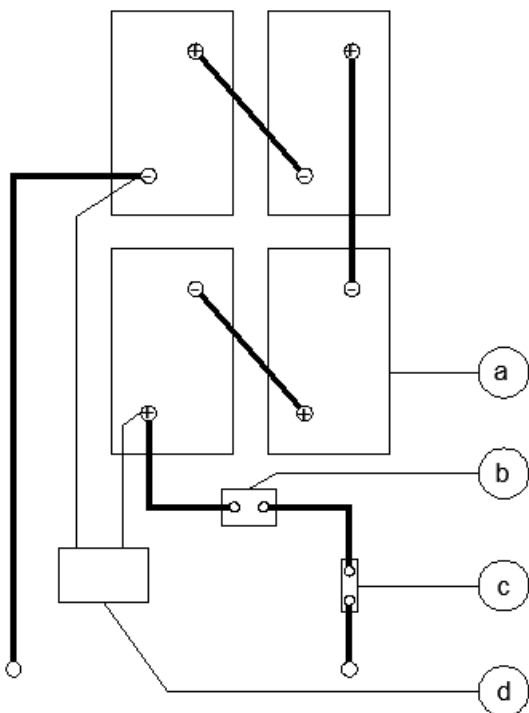

- a 6V batteries
- b power switch
- c fuse
- d battery charger

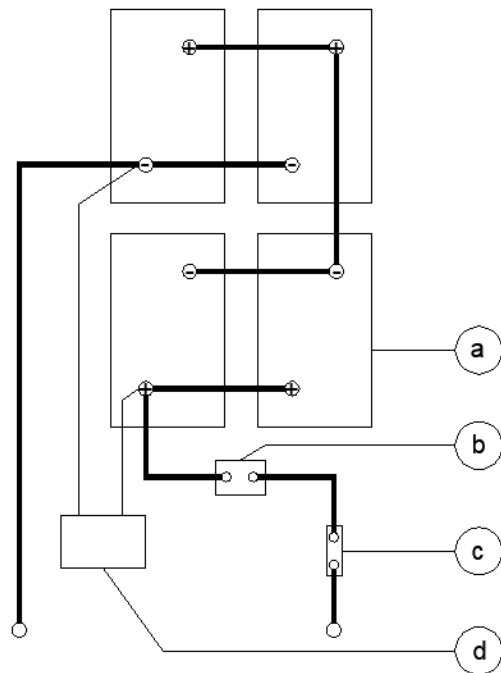

- a 12V batteries
- b power switch
- c fuse
- d battery charger

All models:

- 13 Check each battery pack and verify that the batteries are wired correctly.
- 14 Inspect the battery charger plug and pigtail for damage or excessive insulation wear. Replace as required.
- 15 Connect the battery charger to a properly grounded 110 - 230V / 50 – 60 Hz single phase AC power supply.

- ⊙ Result: The charger should operate and begin charging the batteries.
- ⊗ Result: If, simultaneously, the charger alarm sounds and the LEDs blink, correct the charger connections at the fuse and battery. The charger will then operate correctly and begin charging the batteries.

Note: For best results, use an extension of adequate size with a length no longer than 15m.

Maintenance

Note: The following must be measured and recorded once the battery has been fully charged, after a waiting time of at least 12 hours:

- Total voltage
- Individual voltage of the block battery

If significant changes to previous measurements or differences between the block batteries are identified, then customer service must be contacted for further testing or repairs.

Note: If you have any further questions regarding the battery charger operation, please contact the DINGLI Service Department.

B-2

Inspect the Electrical Wiring



DINGLI requires that this procedure be performed every 250 hours or quarterly, whichever comes first.

Maintaining electrical wiring in good condition is essential to safe operation and good machine performance. Failure to find and replace burnt, chafed, corroded or pinched wires could result in unsafe operating conditions and may cause component damage.

⚠ WARNING Electrocutation / burn hazard.

Contact with electrically charged circuits could result in death or serious injury. Remove all rings, watches and other jewelry.

- 1 Inspect the underside of the chassis for damaged or missing ground strap(s).
- 2 Inspect the following areas for burnt, chafed, corroded and loose wires:
 - Ground control panel
 - Hydraulic power unit module tray
 - Battery pack module tray
 - Platform controls
- 3 Turn the key switch to ground control. Pull out the platform and ground red Emergency Stop button to the on position.
- 4 Raise the platform until the distance of the two sets of scissor at least 0.5m.
- 5 Lift the safety arm, move it to the center of the scissor arm and rotate up to a vertical position.
- 6 Lift the upper safety arm, move it to the center of the scissor arm and rotate down to a vertical position. (for JCPT1412, JCPT1612B, JCPT1612S).

Maintenance

- 7 Lower the platform until the safety arm rests securely on the link. Keep clear of the safety arm when lowering the platform.

⚠ WARNING Crushing hazard. Keep hands clear of the safety arm when lowering the platform.

- 8 Inspect the center chassis area and scissor arms for burnt, chafed and pinched cables.
- 9 Inspect the following areas for burnt, chafed, corroded, pinched and loose wires:
 - Scissor arms
 - ECU to platform controls
 - Power to platform wiring
- 10 Inspect for a liberal coating of dielectric grease in the following locations:
 - Between the ECU and platform controls
 - All wire harness connectors Level sensor
- 11 Raise the platform and return the safety arm to the stowed position.
- 12 Lower the platform to the stowed position and turn the machine off.

B-3

Inspect the Tires and Wheels (including castle nut torque)



DINGLI requires that this procedure be performed every 250 hours or quarterly, whichever comes first.

Maintaining the tires and wheels in good condition is essential to safe operation and good performance. Tire and/or wheel failure could result in a machine tip-over. Component damage may also result if problems are not discovered and repaired in a timely fashion.

- 1 Check the tire surface and sidewalls for cuts, cracks, punctures and unusual wear.
- 2 Check each wheel for damage, bends and cracks.

For HD model machine

- 3 Remove the cotter pin and check each castle nut for proper torque.

Note: Always replace the cotter pin with a new one when removing the castle nut or when checking the torque of the castle nut.

- 4 Install a new cotter pin. Bend the cotter pin to lock it in place.

Castle nut torque, dry	406.7Nm
------------------------	---------

Castle nut torque, lubricated	305Nm
-------------------------------	-------

For DC model machine

- 3 Check each bolt for proper torque.

Bolt torque, dry	88Nm
------------------	------

Bolt torque, lubricated	66Nm
-------------------------	------

Maintenance

B-4

Test the Emergency Stop

DINGLI requires that this procedure be performed every 250 hours or quarterly, whichever comes first.

A properly functioning Emergency Stop is essential for safe machine operation. An improperly operating red Emergency Stop button will fail to shut off power and stop all machine functions, resulting in a hazardous situation.

As a safety feature, selecting and operating the ground controls will override the platform controls, except the platform red Emergency Stop button.

- 1 Turn the key switch to ground control. Pull out the platform and ground red Emergency Stop button to the on position.
 - 2 Push in the red Emergency Stop button at the ground controls to the off position.
- ⊙ Result: No machine functions should operate.
- 3 Turn the key switch to platform control. Pull out the platform and ground red Emergency Stop button to the on position.
 - 4 Push in the red Emergency Stop button at the platform controls to the off position.
- ⊙ Result: No machine functions should operate.

Note: The red Emergency Stop button at the ground controls will stop all machine operation, even if the key switch is switched to platform control.

B-5

Test the Key Switch

DINGLI requires that this procedure be performed every 250 hours or quarterly, whichever comes first.

Proper key switch action and response is essential to safe machine operation. The machine can be operated from the ground or platform controls and the activation of one or the other is accomplished with the key switch. Failure of the key switch to activate the appropriate control panel could cause a hazardous operating situation.

Perform this procedure from the ground using the platform controls. Do not stand in the platform.

- 1 Pull out the platform and ground red Emergency Stop button to the on position.
 - 2 Turn the key switch to platform control.
 - 3 Check the platform up/down function from the ground controls.
- ⊙ Result: The machine functions should not operate.
- 4 Turn the key switch to ground control.
 - 5 Check the machine functions from the platform controls.
- ⊙ Result: The machine functions should not operate.
- 6 Turn the key switch to the off position.
- ⊙ Result: No function should operate.

B-6**Test the Automotive-style Horn (if equipped)**

DINGLI requires that this procedure be performed every 250 hours or quarterly, whichever comes first.

The horn is activated at the platform controls and sounds at the ground as a warning to ground personnel. An improperly functioning horn will prevent the operator from alerting ground personnel of hazards or unsafe conditions.

- 1 Turn the key switch to platform control. Pull out the platform and ground red Emergency Stop button to the on position.
 - 2 Push down the horn button at the platform controls.
- ⊙ Result: The horn should sound.

B-7**Test the Drive Brakes**

DINGLI requires that this procedure be performed every 250 hours or quarterly, whichever comes first.

Proper brake action is essential to safe machine operation. The drive brake function should operate smoothly, free of hesitation, jerking and unusual noise.

Hydraulically-released individual wheel brakes can appear to operate normally when not fully operational.

Perform this procedure with the machine on a firm level surface that is free of obstructions, with the platform extension deck fully retracted and the platform in the stowed position.

- 1 Mark a test line on the ground for reference.
- 2 Turn the key switch to platform control. Pull out the platform and ground red Emergency Stop button to the on position.
- 3 Lower the platform to the stowed position.
- 4 Press the drive function select button.

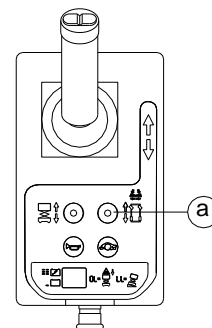

a drive function select button

- 5 Choose a point on the machine; i.e., contact patch of a tire, as a visual reference for use when crossing the test line.

Maintenance

- 6 Bring the machine to top drive speed before reaching the test line. Release the function enable switch or the joystick when your reference point on the machine crosses the test line.
- 7 Measure the distance between the test line and your machine reference point.
 - ⊙ Result: The machine stops within the specified braking distance. No action required.
 - ⊘ Result: The machine does not stop within the specified braking distance.

Note: The brakes must be able to hold the machine on any slope it is able to climb.

- 8 Replace the brakes and repeat this procedure beginning with step 1.

Braking distance, maximum

High range on paved surface 61cm ± 30cm

B-8

Test the Drive Speed - Stowed Position



DINGLI requires that this procedure be performed every 250 hours or quarterly, whichever comes first.

Proper drive functions are essential to safe machine operation. The drive function should respond quickly and smoothly to operator control. Drive performance should also be free of hesitation, jerking and unusual noise over the entire proportionally controlled speed range.

Perform this procedure with the machine on a firm, level surface that is free of obstructions.

- 1 Create start and finish lines by marking two lines on the ground 12.2 m apart.
- 2 Turn the key switch to platform control. Pull out the platform and ground red Emergency Stop button to the on position.
- 3 Lower the platform to the stowed position.
- 4 Press the drive function select button.

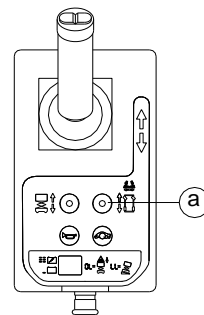

a drive function select button

- 5 Choose a point on the machine; i.e., contact patch of a tire, as a visual reference for use when crossing the start and finish lines.
- 6 Bring the machine to top drive speed before reaching the start line. Begin timing

when your reference point on the machine crosses the start line.

- 7 Continue at full speed and note the time when your reference point on the machine passes over the finish line. Refer to specifications.

B-9**Test the Drive Speed - Raised Position**

DINGLI requires that this procedure be performed every 250 hours or quarterly, whichever comes first.

Proper drive functions are essential to safe machine operation. The drive function should respond quickly and smoothly to operator control. Drive performance should also be free of hesitation, jerking and unusual noise over the entire proportionally controlled speed range.

Perform this procedure with the machine on a firm, level surface that is free of obstructions.

- 1 Create start and finish lines by marking two lines on the ground 12.2 m apart.
- 2 Turn the key switch to platform control. Pull out the platform and ground red Emergency Stop button to the on position.
- 3 Press the lift function select button.

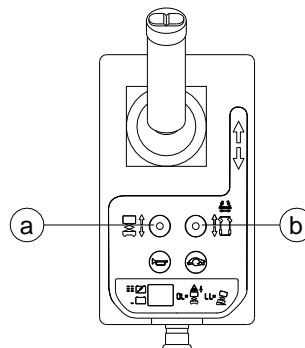

- a lift function select button
b drive function select button

- 4 Press and hold the function enable switch on the joystick.
- 5 Raise the platform approximately 2 m from the ground.
- 6 Press the drive function select button.

Maintenance

- 7 Choose a point on the machine; i.e., contact patch of a tire, as a visual reference for use when crossing the start and finish lines.
- 8 Bring the machine to top drive speed before reaching the start line. Begin timing when your reference point on the machine crosses the start line.
- 9 Continue at full speed and note the time when your reference point on the machine passes over the finish line. Refer to specifications.

B-10

Test the Slow Drive Speed



DINGLI requires that this procedure be performed every 250 hours or quarterly, whichever comes first.

Proper drive functions are essential to safe machine operation. The drive function should respond quickly and smoothly to operator control. Drive performance should also be free of hesitation, jerking and unusual noise over the entire proportionally controlled speed range.

Perform this procedure with the machine on a firm, level surface that is free of obstructions.

- 1 Create start and finish lines by marking two lines on the ground 12.2 m apart.
- 2 Turn the key switch to platform control. Pull out the platform and ground red Emergency Stop button to the on position.
- 3 Lower the platform to the stowed position.
- 4 Press the slow speed select button.

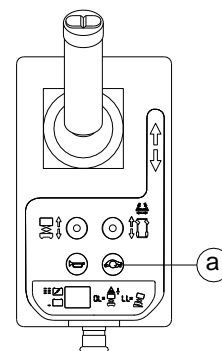

a slow speed select button

- 5 Choose a point on the machine; i.e., contact patch of a tire, as a visual reference for use when crossing the start and finish lines.
- 6 Bring the machine to top drive speed before reaching the start line. Begin timing

Maintenance

when your reference point on the machine crosses the start line.

- 7 Continue at full speed and note the time when your reference point on the machine passes over the finish line. The time is less than 25 sec.

B-11

Perform Hydraulic Oil Analysis



DINGLI requires that this procedure be performed every 250 hours or quarterly, whichever comes first.

Replacement or testing of the hydraulic oil is essential for good machine performance and service life. Dirty oil may cause the machine to perform poorly and continued use may cause component damage. Extremely dirty conditions may require oil changes to be performed more often.

Before replacing the hydraulic oil, the oil may be tested by an oil distributor for specific levels of contamination to verify that changing the oil is necessary.

If the hydraulic oil is not replaced at the two year inspection, test the oil quarterly. Replace the oil when it fails the test. See E-1, Test or Replace the Hydraulic Oil.

Maintenance

B-12

Inspect the Hydraulic Tank Cap Venting System



DINGLI requires that this procedure be performed quarterly or every 250 hours, whichever comes first. Perform this procedure more often if dusty conditions exist.

A free-breathing hydraulic tank cap is essential for good machine performance and service life. A dirty or clogged cap may cause the machine to perform poorly. Extremely dirty conditions may require that the cap be inspected more often.

- 1 Remove the breather cap from the hydraulic tank.
 - 2 Check for proper venting.
- ☉ Result: Air passes through the breather cap.
- ☒ Result: If air does not pass through the cap, clean or replace the cap. Proceed to step 3.

Note: When checking for positive tank cap venting, air should pass freely through the cap.

- 3 Using a mild solvent, carefully wash the cap venting system. Dry using low pressure compressed air. Repeat step 2.
- 4 Install the breather cap onto the hydraulic tank.

B-13

Check the Module Tray Latch Components



DINGLI requires that this procedure be performed every 250 hours or quarterly, whichever comes first.

Maintaining the module tray latch components in good condition is essential to good performance and service life. Failure to detect worn out latch components may result in module trays opening unexpectedly, creating an unsafe operating condition.

- 1 Inspect each module tray rotary latch and related components for wear. Tighten any loose fasteners.
- 2 Lubricate each module tray rotary latch. Using light oil, apply a few drops to each of the springs and to the sides of the rotary latch mechanism.

B-14**Test the Down Limit Switch, the Pothole Limit Switches and the Level Sensor**

DINGLI requires that this procedure be performed every 250 hours or quarterly, whichever comes first.

Maintaining the limit switches is essential to safe operation and good machine performance. Operating the machine with a faulty limit switch could result in reduced machine performance and a potentially unsafe operating condition.

Perform these procedures with the machine on a firm, level surface that is free of obstructions.

Down Limit Switch

- 1 Remove the platform controls from the platform.
 - 2 Raise the platform until the distance of the two sets of scissor at least 0.5m.
 - 3 Lift the safety arm, move it to the center of the scissor arm and rotate up to a vertical position.
 - 4 Lift the upper safety arm, move it to the center of the scissor arm and rotate down to a vertical position. (for JCPT1412, JCPT1612B, JCPT1612S).
 - 5 Lower the platform until the safety arm rests securely on the link. Keep clear of the safety arm when lowering the platform.
- ⚠ WARNING** Crushing hazard. Keep hands clear of the safety arm when lowering the platform.
- 6 Turn the key switch to the off position.
 - 7 Tag and disconnect the platform control box at the platform.
 - 8 Follow the platform control cable down the scissor stack to the underside of the chassis deck. Tag and disconnect the platform cable from the ECU cable at the 6-pin Deutsch connector under the chassis deck.
 - 9 Securely install the platform control box harness plug into the 6-pin Deutsch connector of the ECU cable.
 - 10 Open the down limit switch cover, tag and disconnect the wires of the down limit switch wire harness.
 - 11 Turn the key switch to platform control.
 - 12 Raise the platform and return the safety arm to the stowed position.
 - 13 Working at the platform controls, press the lift function select button. Lower the platform to the stowed position.
 - ⊙ Result: The LED readout screen will show code 18, an alarm sounds and the lift function should operate. The machine is functioning properly.
 - ⊗ Result: The LED readout screen does not show code 18, the alarm does not sound and the lift function should not operate. Replace the down limit switch.
 - 14 Press the drive function select button. Attempt to drive the machine.
 - ⊙ Result: The LED readout screen will show code 18, an alarm sounds, and the steer and drive functions should not operate. The machine is functioning properly.
 - ⊗ Result: The LED readout screen does not

Maintenance

- show code 18, the alarm does not sound, and the steer and drive functions operate. Replace the down limit switch.
- 15 Press the lift function select button. Raise the platform approximately 0.3 m.
 - ⊙ Result: The LED readout screen will show code 18 and an alarm sounds. The machine is functioning properly.
 - ⊗ Result: The LED readout screen does not show code 18 and the alarm does not sound. Replace the down limit switch.
 - 16 Raise the platform until the pothole guards are deployed.
 - ⊙ Result: The LED readout screen does not show code 18 and the alarm does not sound. The machine is functioning properly.
 - ⊗ Result: The LED readout screen shows code 18 and an alarm sounds. Replace the down limit switch.
 - 17 Raise the platform until the distance of the two sets of scissor at least 0.5m.
 - 18 Lift the safety arm, move it to the center of the scissor arm and rotate up to a vertical position.
 - 19 Lift the upper safety arm, move it to the center of the scissor arm and rotate down to a vertical position. (for JCPT1412, JCPT1612B, JCPT1612S).
 - 20 Lower the platform until the safety arm rests securely on the link. Keep clear of the safety arm when lowering the platform.

⚠ WARNING

 Crushing hazard. Keep hands clear of the safety arm when lowering the platform.
 - 21 Turn the key switch to the off position.
 - 22 Disconnect the platform controls from the ECU cable.
 - 23 Securely install the connector of the ECU cable into the platform control cable.
 - 24 Working at the platform, securely install the connector of the platform controls into the platform control cable.
 - 25 Securely connect the two wires of the down limit switch to wire harness.
 - 26 Close and install the switch cover.
 - 27 Turn the key switch to platform control.
 - 28 Raise the platform and return the safety arm to the stowed position.
 - 29 Lower the platform to the stowed position.
- ### Level sensor
- 30 Move the machine onto a grade which exceeds the rating of the level sensor. Refer to the serial label on the machine.
 - 31 Press the lift function select button. Standing on the up-hill side of the machine, attempt to raise the platform to approximately 2.4 m.
 - ⊙ Result: The LED readout screen shows code LL, an alarm sounds, and the machine stops lifting after the pothole guards are deployed. The machine is functioning properly.
 - ⊗ Result: The LED readout screen does not show code LL, the alarm does not sound and the machine will continue to lift the platform after the pothole guards are deployed. Adjust or replace the level sensor.
 - 32 Press the drive function select button. Standing on the up-hill side of the machine, attempt to steer and drive the machine.
 - ⊙ Result: The LED readout screen shows code LL, an alarm sounds, and the machine will not steer or drive. The machine is functioning properly.
 - ⊗ Result: The LED readout screen does not

Maintenance

show code LL, the alarm does not sound and the steer and drive functions operate. Adjust or replace the level sensor.

Pothole Limit Switches

33 Lower the platform to the stowed position. Move the machine onto a firm, level surface.

34 Place a wooden block approximately 5 cm tall under the right pothole guard.

35 Press the lift function select button. Attempt to raise the platform approximately 2.4m.

⊙ Result: The pothole guard contacts the block and does not fully deploy, the LED readout screen shows code 18, an alarm sounds and the platform will lift to 2.4m or beyond. The machine is functioning properly.

⊘ Result: The pothole guard contacts the block and does not fully deploy, the LED readout screen does not show code 18, the alarm does not sound and the machine will continue to lift the platform after the pothole guards are deployed. Adjust or replace the pothole limit switch.

36 Press the drive function select button. Attempt to steer or drive the machine.

⊙ Result: The LED readout screen shows code 18, an alarm sounds, and the machine will not steer or drive. The machine is functioning properly.

⊘ Result: The LED readout screen does not show code 18, the alarm does not sound and the steer and drive functions operate. Adjust or replace the down limit switch.

37 Lower the platform to the stowed position and remove the block under the right pothole guard.

38 Repeat this procedure beginning with step 34 for the left pothole guard.

39 Lower the platform to the stowed position, remove the block under the left pothole guard.

40 Turn off the machine.

Maintenance

B-15

Test the Up Limit Switch



DINGLI requires that this procedure be performed every 250 hours or quarterly, whichever comes first.

Maintaining the limit switches is essential to safe operation and good machine performance.

Operating the machine with a faulty limit switch could result in reduced machine performance and a potentially unsafe operating condition.

Perform these procedures with the machine on a firm, level surface that is free of obstructions.

- 1 Raise the platform until the distance of the two sets of scissor at least 0.5m.
- 2 Lift the safety arm, move it to the center of the scissor arm and rotate up to a vertical position.
- 3 Lift the upper safety arm, move it to the center of the scissor arm and rotate down to a vertical position. (for JCPT1412, JCPT1612B, JCPT1612S).
- 4 Lower the platform until the safety arm rests securely on the link. Keep clear of the safety arm when lowering the platform.

⚠ WARNING Crushing hazard. Keep hands clear of the safety arm when lowering the platform.

- 5 Open the limited switch house cover from the chassis.
- 6 While raising the platform from the ground controls, push in the roller of the up limit switch to activate the limit switch.

⊙ Result: The platform stops raising. The machine is functioning properly.

- ⊗ Result: The platform continues to raise. Adjust or replace the up limit switch.
- 7 Install the limited switch house cover to chassis.
- 8 Put the safe arm to home position.
- 9 Lower the platform to the stowed position.

Checklist C Procedures

C-1

Test the Platform Overload System (if equipped)



DINGLI requires that this procedure be performed every 500 hours or six months, whichever comes first or when the machine fails to lift the maximum rated load.

Testing the platform overload system regularly is essential to safe machine operation. Continued use of an improperly operating platform overload system could result in the system not sensing an overloaded platform condition. Machine stability could be compromised resulting in the machine tipping over.

The platform overload system is designed to prevent machine operation in the event the platform is overloaded. Models equipped with the platform overload option are provided with two additional machine control components: the overload pressure sensor and angle sensor.

The overload pressure sensor, which is adjustable and located at the barrel-end of the lift cylinder, is used to determine when the hydraulic lift cylinder requires too much pressure to support the load inside the platform. When this occurs, the overload pressure sensor will send a signal to the ECU, which will not allow the machine to function until the extra weight is removed from the platform.

The angle sensor, located in the inner scissor arm 1, is used to determine the tilt of scissor, than to measure the height of platform.

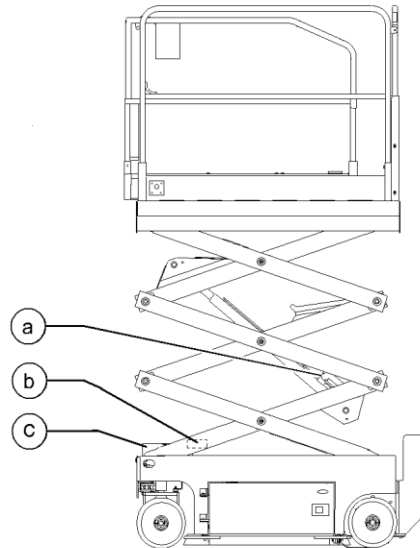

- a overload pressure sensor
- b angle sensor
- c limited switch cover

- 1 Raise the platform until the distance of the two sets of scissor at least 0.5m.
- 2 Lift the safety arm, move it to the center of the scissor arm and rotate up to a vertical position.
- 3 Lift the upper safety arm, move it to the center of the scissor arm and rotate down to a vertical position. (for JCPT1412, JCPT1612B, JCPT1612S).
- 4 Lower the platform until the safety arm rests securely on the link. Keep clear of the safety arm when lowering the platform.

WARNING Crushing hazard. Keep hands clear of the safety arm when lowering the platform.

Maintenance

- 5 Open the limited switch house cover from the chassis.
- 6 Open the up limited switch cover.

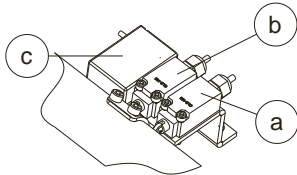

- a up limited switch
- b down limited switch
- c slope sensor

- 7 Tag and disconnect the wires of the up limit switch wire harness.
- 8 Securely connect together the terminals of the two wires of the up limit switch.
- 9 Turn the key switch to ground control. Pull out the platform and ground red Emergency Stop button to the on position.
- 10 Raise the platform to release the safe arm. Put the safe arm to home position.
- 11 Fully raise the platform. Release the toggle switch.
- 12 Using the emergency lowering knob, lower the platform to the stowed position.
- 13 Securely connect the wires of the up limit switch.
- 14 Fully raise the platform. Release the toggle switch.
- 15 Lower the platform until the distance of the two sets of scissor at least 0.5m.
- 16 Lift the safety arm, move it to the center of the scissor arm and rotate up to a vertical position.
- 17 Lift the upper safety arm, move it to the center of the scissor arm and rotate down to a vertical position. (for JCPT1412, JCPT1612B, JCPT1612S).
- 18 Lower the platform until the safety arm rests securely on the link. Keep clear of the safety arm when lowering the platform

⚠ WARNING Crushing hazard. Keep hands clear of the safety arm when lowering the platform.

- 19 Install the up limited switch cover.
 - 20 Install the limited switch house cover.
 - 21 Raise the platform to release the safe arm.
 - 22 Put the safe arm to home position.
 - 23 Lower the platform to the stowed position.
- ⊙ Result: The alarm should sound.
 - ⊖ Result: The alarm does not sound. Calibrate the platform overload system.
 - ⊙ Result: The alarm should not sound. The system is functioning correctly.
 - ⊖ Result: The alarm sounds. The system is not functioning correctly. Troubleshoot the limit switch, limit switch wire harness or limit switch mount bracket or the platform overload system needs to be calibrated.

C-2**Replace the Hydraulic Tank Breather Cap**

DINGLI requires that this procedure be performed every 500 hours or semi-annually, whichever comes first.

The hydraulic tank is a vented-type tank. The breather cap has an internal air filter that can become clogged or, over time, can deteriorate. If the breather cap is faulty or improperly installed, impurities can enter the hydraulic system which may cause component damage. Extremely dirty conditions may require that the cap be inspected more often.

- 1 Remove and discard the hydraulic tank breather cap.
- 2 Install a new cap onto the tank.

Maintenance

Checklist D Procedures

D-1

Check the Scissor Arm Wear Pads



DINGLI requires that this procedure be performed every 1000 hours or annually, whichever comes first.

Maintaining the condition of the scissor arm wear pads is essential to safe machine operation. Continued use of worn out wear pads may result in component damage and unsafe operating conditions.

Perform this procedure with the platform in the stowed position.

- 1 Measure the distance between the number one arm cross tube and the chassis deck at the ground controls side of the non-steer end of the machine.

☉ Result: The measurement is 34mm or more.
Proceed to step 2.

☒ Result: The measurement is less than 34mm. Replace both wear pads.

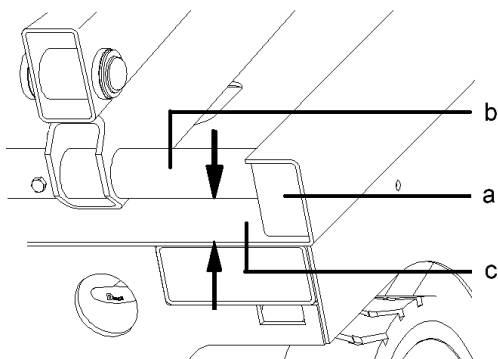

- a wear pad
- b arm cross tube
- c chassis deck

- 2 Measure the distance between the number one arm cross tube and the chassis deck at the battery pack side of the non-steer end of the machine.

☉ Result: The measurement is 34mm or more.
Proceed to step 3.

☒ Result: The measurement is less than 34 mm. Replace both wear pads.

- 3 Apply a thin layer of dry film lubricant to the area of the chassis where the scissor arm wear pads make contact.

D-2**Replace the Hydraulic Tank Return Filter Element**

DINGLI requires that this procedure be performed every 1000 hours or annually, whichever comes first.

Replacement of the hydraulic tank return filter is essential for good machine performance and service life. A dirty or clogged filter may cause the machine to perform poorly and continued use may cause component damage. Extremely dirty conditions may require that the filter be replaced more often.

CAUTION Beware of hot oil. Contact with hot oil may cause severe burns.

NOTICE The hydraulic tank return filter is mounted on the bracket between the function manifold and the hydraulic power unit.

- 1 Clean the area around the oil filter.
Remove the filter with an oil filter wrench.
- 2 Apply a thin layer of oil to the new oil filter gasket.
- 3 Install the new filter and tighten it securely by hand.
- 4 Use a permanent ink marker to write the date and number of hours from the hour meter onto the filter.
- 5 Turn the key switch to ground control. Pull out the platform and ground red Emergency Stop button to the on position.
- 6 Activate and hold the platform up toggle switch.
- 7 Inspect the filter and related components to be sure that there are no leaks.
- 8 Clean up any oil that may have spilled.

Maintenance

Checklist E Procedure

E-1

Test or Replace the Hydraulic Oil



DINGLI requires that this procedure be performed every 2000 hours or every two years, whichever comes first.

Replacement or testing of the hydraulic oil is essential for good machine performance and service life. Dirty oil may cause the machine to perform poorly and continued use may cause component damage. Extremely dirty conditions may require oil changes to be performed more often.

Before replacing the hydraulic oil, the oil may be tested by an oil distributor for specific levels of contamination to verify that changing the oil is necessary.

If the hydraulic oil is not replaced at the two year inspection, test the oil quarterly. Replace the oil when it fails the test.

Note: Perform this procedure with the platform in the stowed position.

- 1 Disconnect the battery pack from the machine.

⚠ WARNING Electrocutation / burn hazard: Contact with electrically charged circuits could result in death or serious injury. Remove all rings, watches and other jewelry.

- 2 Open the power unit module tray.
- 3 Remove the oil drain plug at bottom.
- 4 Drain all of the oil into a suitable container.
- 5 Tag and disconnect the hydraulic tank return line from the hydraulic filter head and remove the line from the tank. Cap the fitting on the filter head.

- 6 Tag and disconnect the hydraulic pump inlet line and remove the line from the tank. Cap the fitting on the pump.

- 7 Remove the hydraulic tank retaining fasteners and remove the hydraulic tank from the machine.

⚠ WARNING Bodily injury hazard.

Spraying hydraulic oil can penetrate and burn skin. Loosen hydraulic connections very slowly to allow the oil pressure to dissipate gradually. Do not allow oil to squirt or spray.

- 8 Clean up any oil that may have spilled. Properly discard the used oil.
- 9 Clean the inside of the hydraulic tank using a mild solvent. Allow the tank to dry completely.
- 10 Install a new filter onto the tank.
- 11 Tighten the drain plug. Torque to specification.

Torque specifications

Hydraulic tank drain plug, dry	4.5Nm
Hydraulic tank drain plug, lubricated	3.4Nm

- 12 Install the hydraulic tank and install and tighten the hydraulic tank retaining fasteners. Torque to specification.

Torque specifications

Hydraulic tank retaining fasteners, dry	4Nm
Hydraulic tank drain plug, lubricated	2.9Nm

Maintenance

- 13 Install the hydraulic pump inlet line into the tank. Install the fitting onto the pump and torque.
- 14 Install the hydraulic pump return line into the tank. Install the fitting onto the hydraulic filter head and torque.
- 15 Fill the tank with hydraulic oil until the fluid is full in the hydraulic tank. Do not overfill.
- 16 Activate the pump to fill the hydraulic system with oil and bleed the system of air.

⚠ WARNING Component damage hazard.
The pump can be damaged if operated without oil. Be careful not to empty the hydraulic tank while in the process of filling the hydraulic system. Do not allow the pump to cavitate.

Schematic

Hydraulic Schematic

JCPT0808HD JCPT1008HD JCPT1012HD

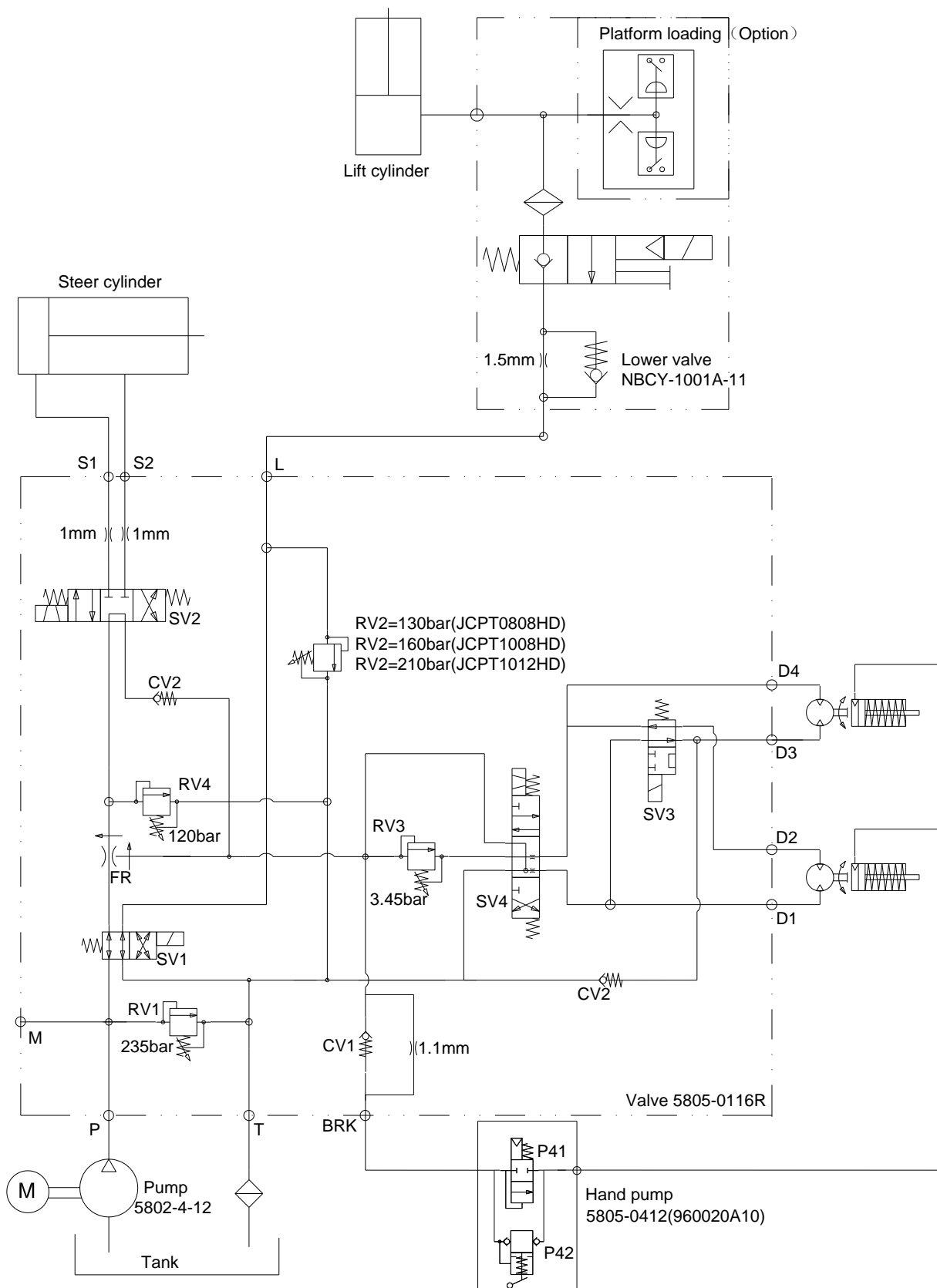

Schematic

JCPT1212HD JCPT1412HD

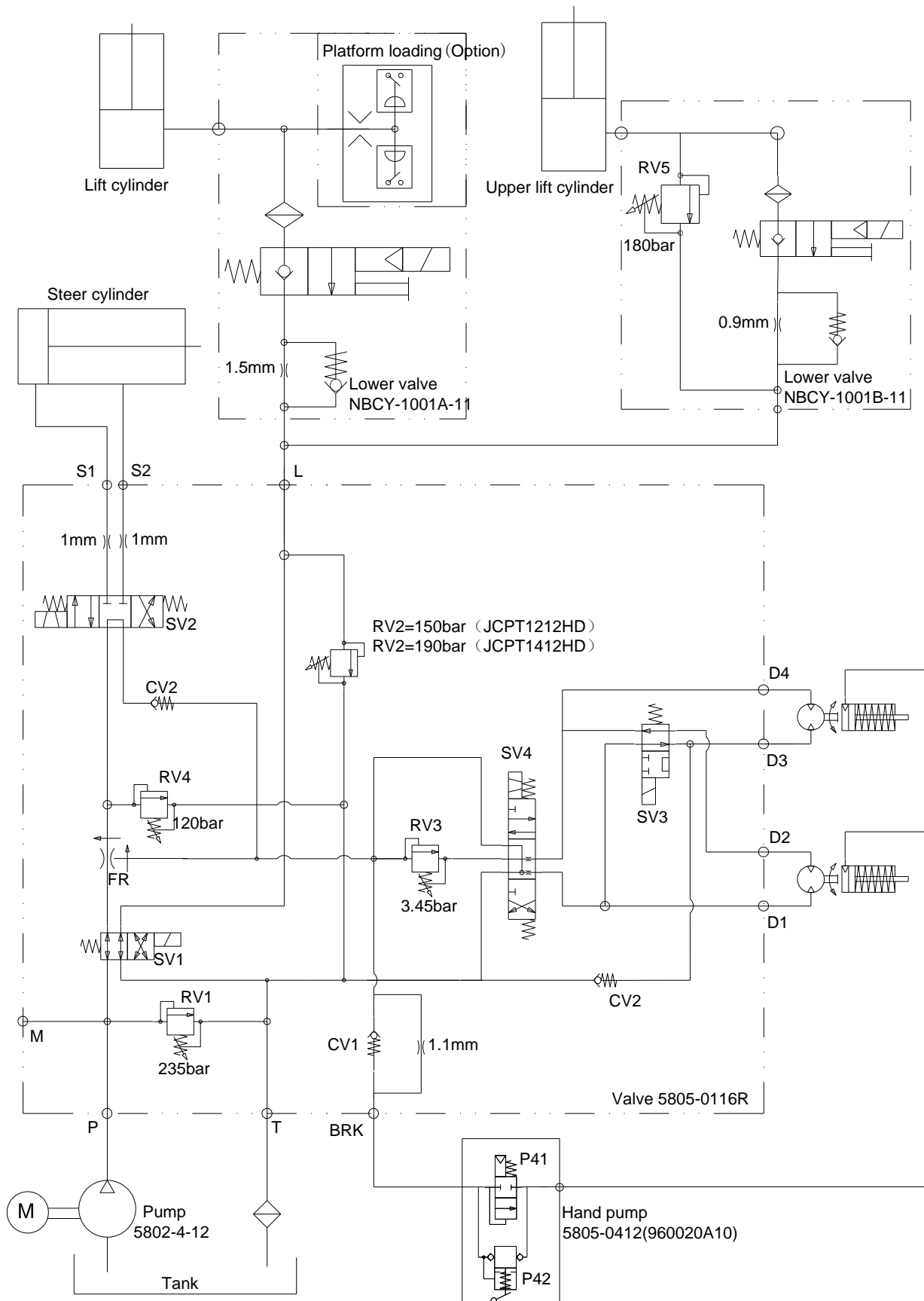

Schematic

JCPT1612HDB JCPT1612HDS

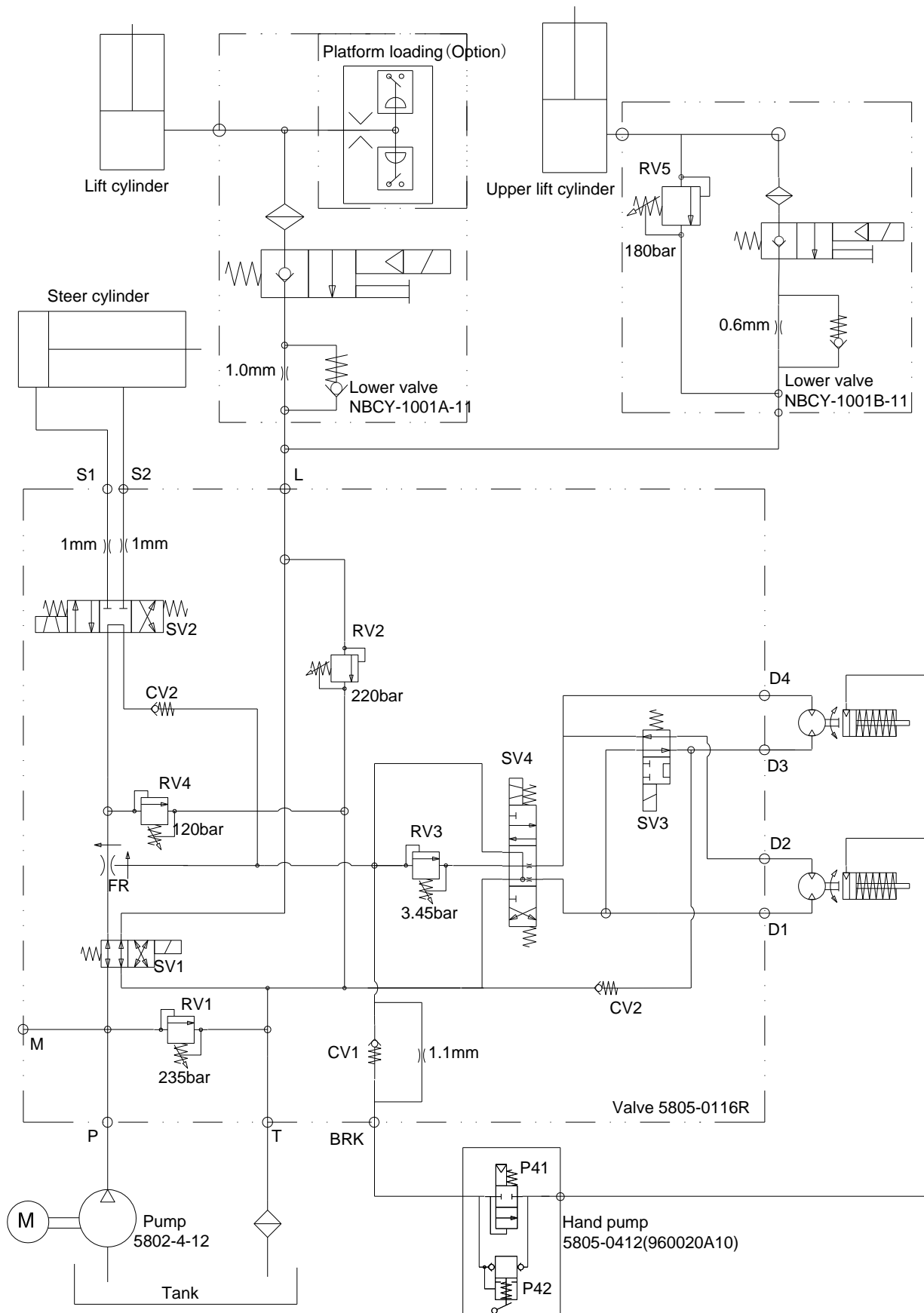

Schematic

JCPT0808DC JCPT1008DC JCPT1012DC

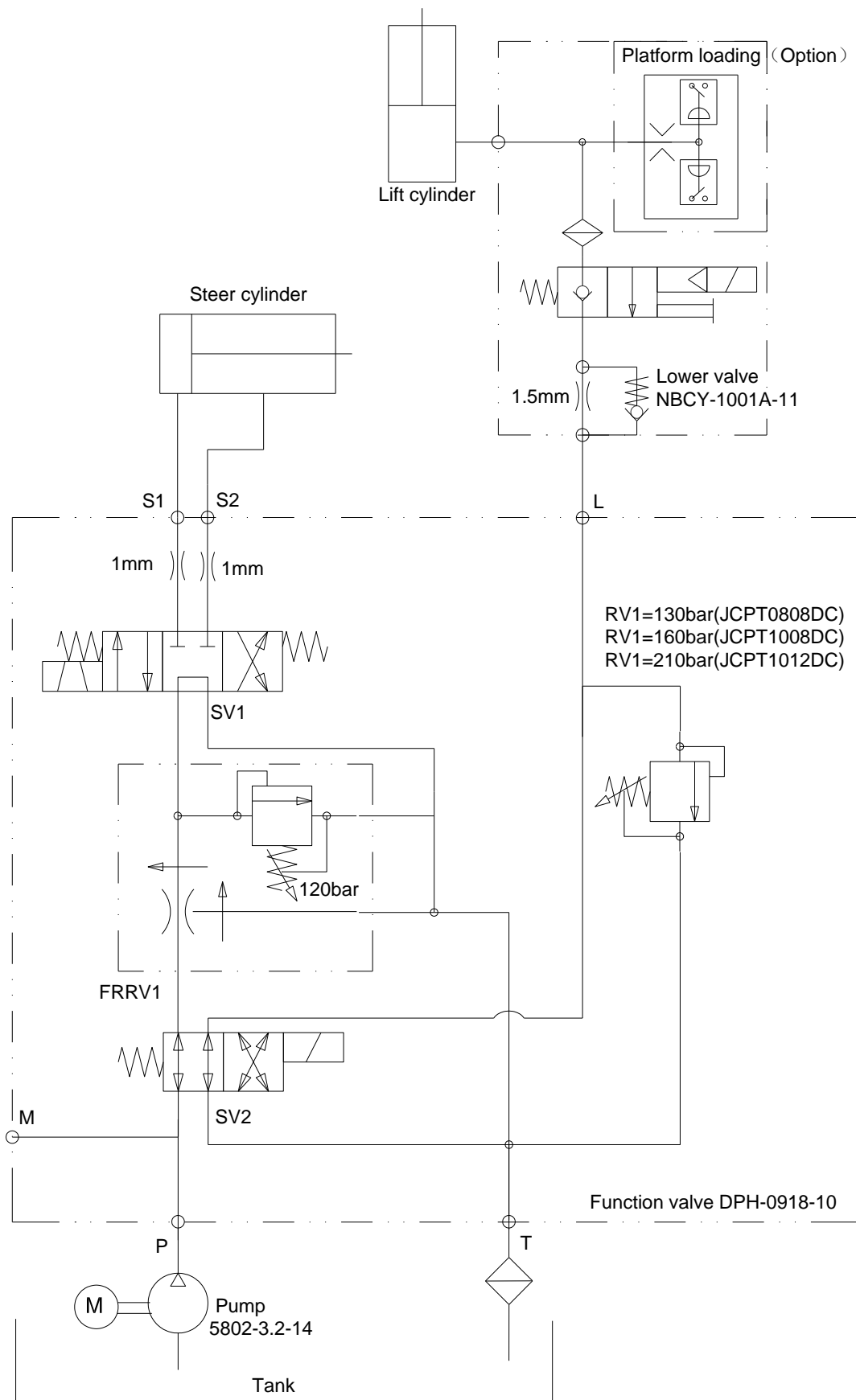

Schematic

JCPT1212DC JCPT1412DC

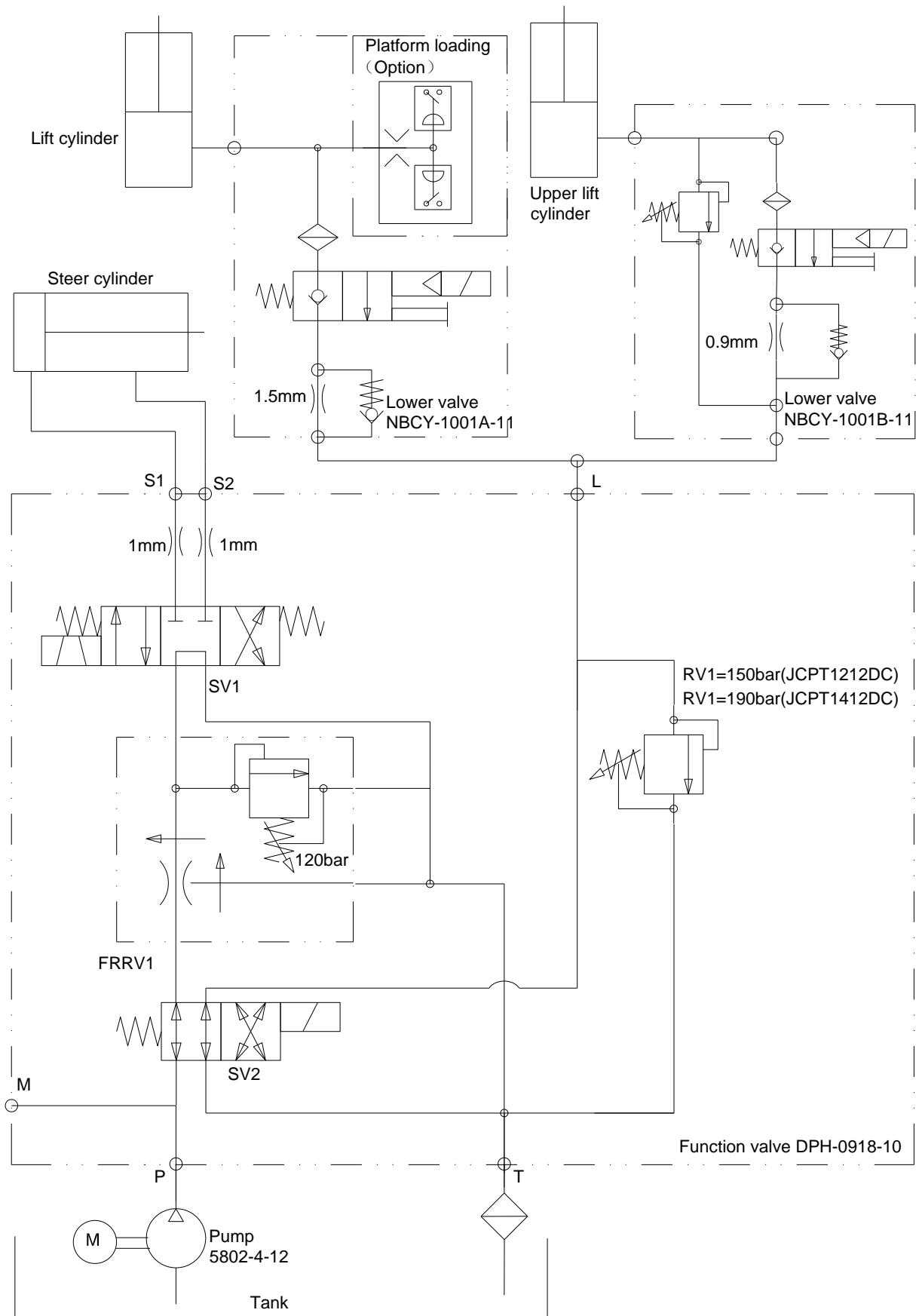

Schematic

JCPT1612DCB JCPT1612DCS

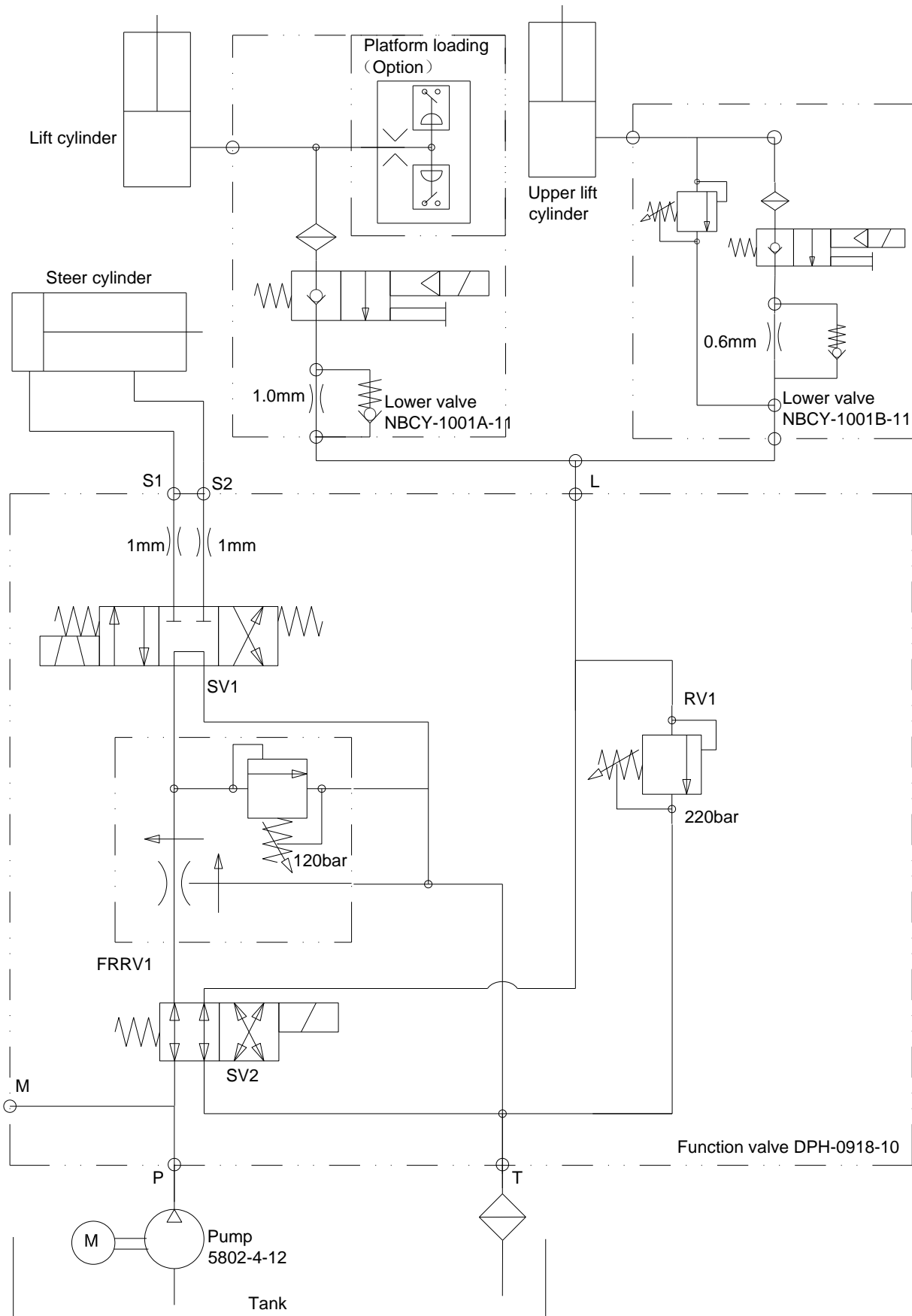

Schematic

Electrical Schematic

JCPT0808HD JCPT1008HD JCPT1012HD JCPT1212HD

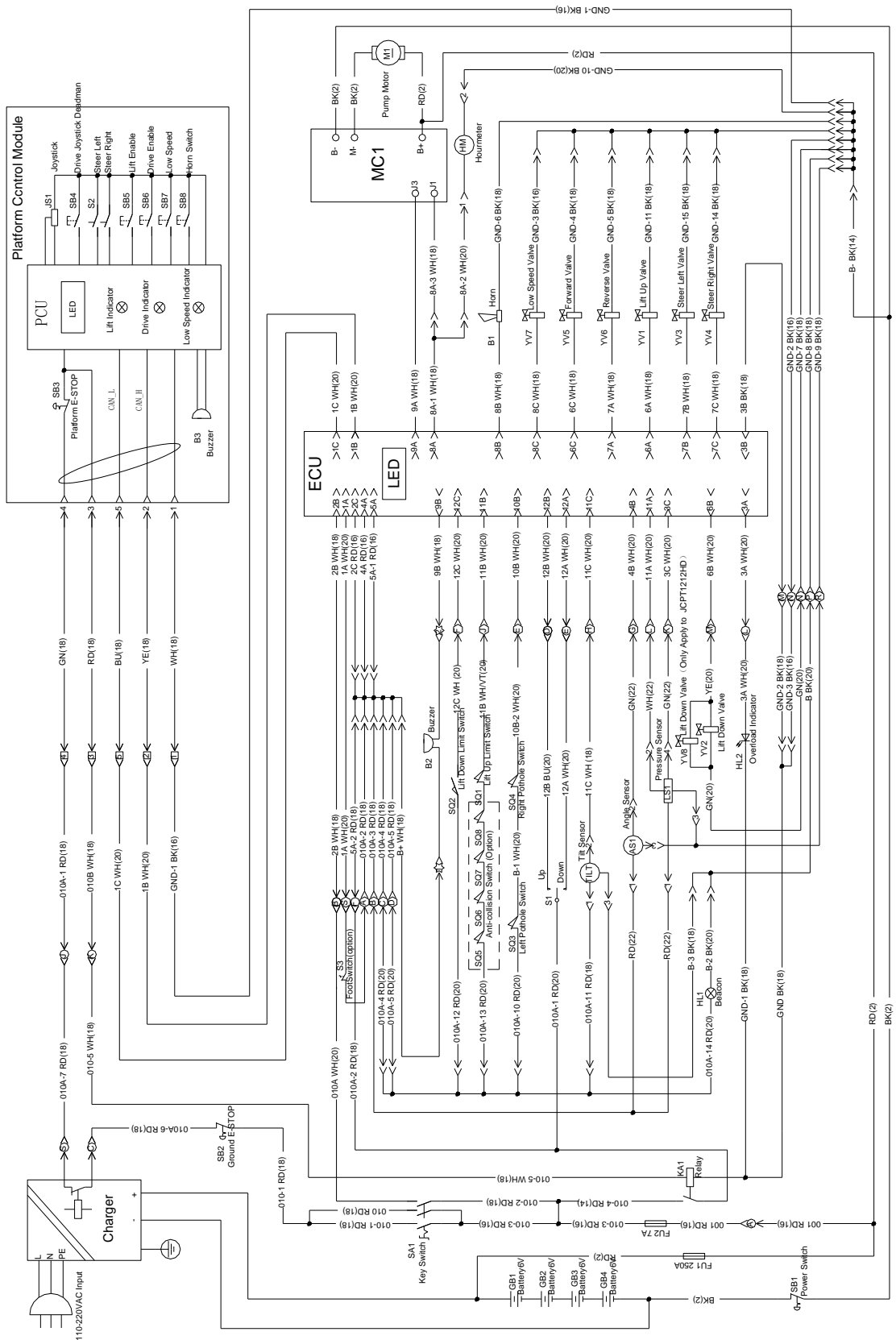

◀=16 Position DELPHI Connector LOC2
 ◀=2 Position AMP Connector LOC4
 ◀=16 Position DELPHI Connector LOC3
 ◀=5 Position SIBAS Connector LOC7

JCPT1412HD JCPT1612HDB JCPT1612HDS

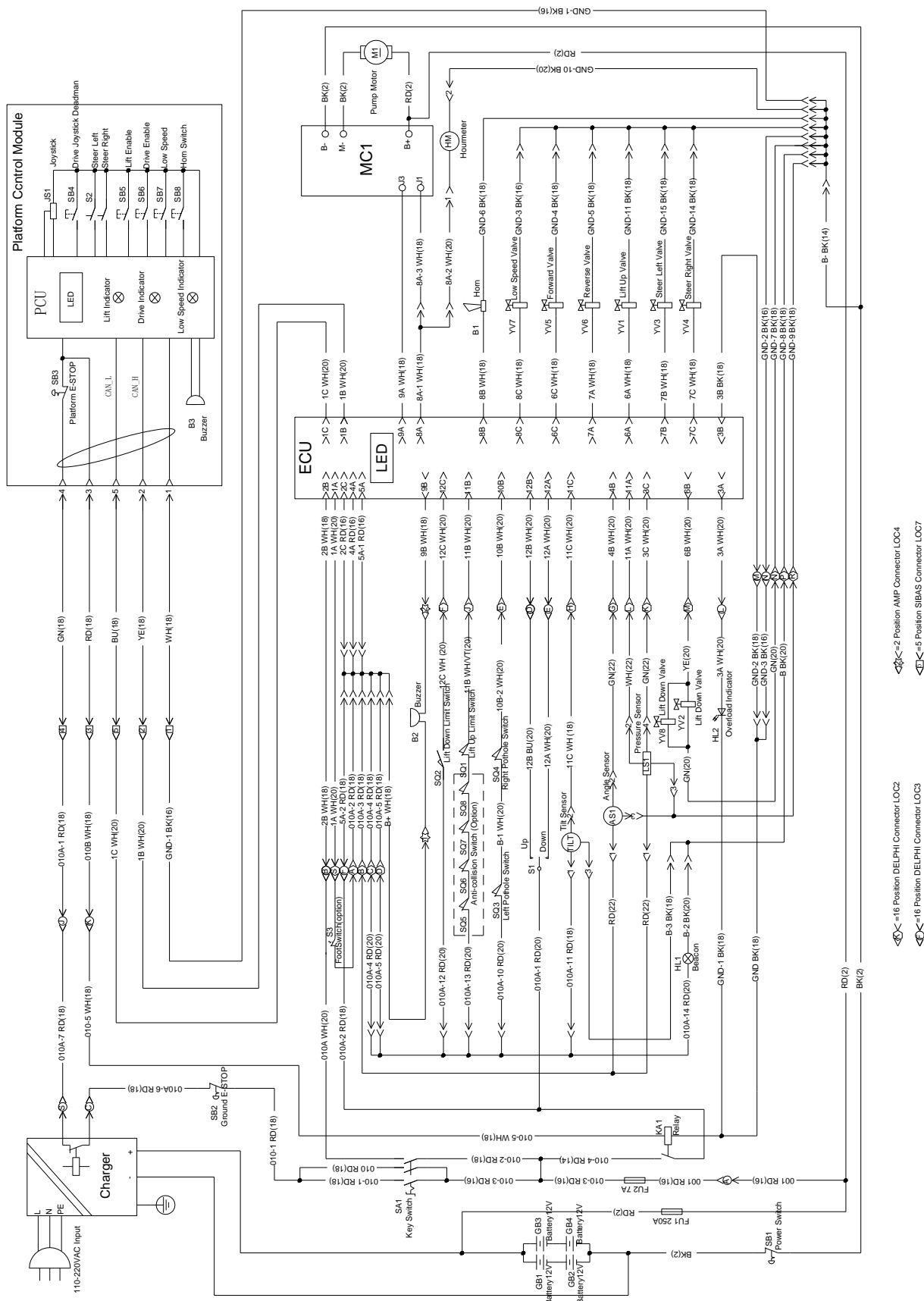

◁ =16 Position DELPHI Connector LOC2
 ◁ =2 Position AMP Connector LOC4
 ◁ =5 Position SIBAS Connector LOC7

Schematic

JCPT0808DC JCPT1008DC JCPT1012DC JCPT1212DC

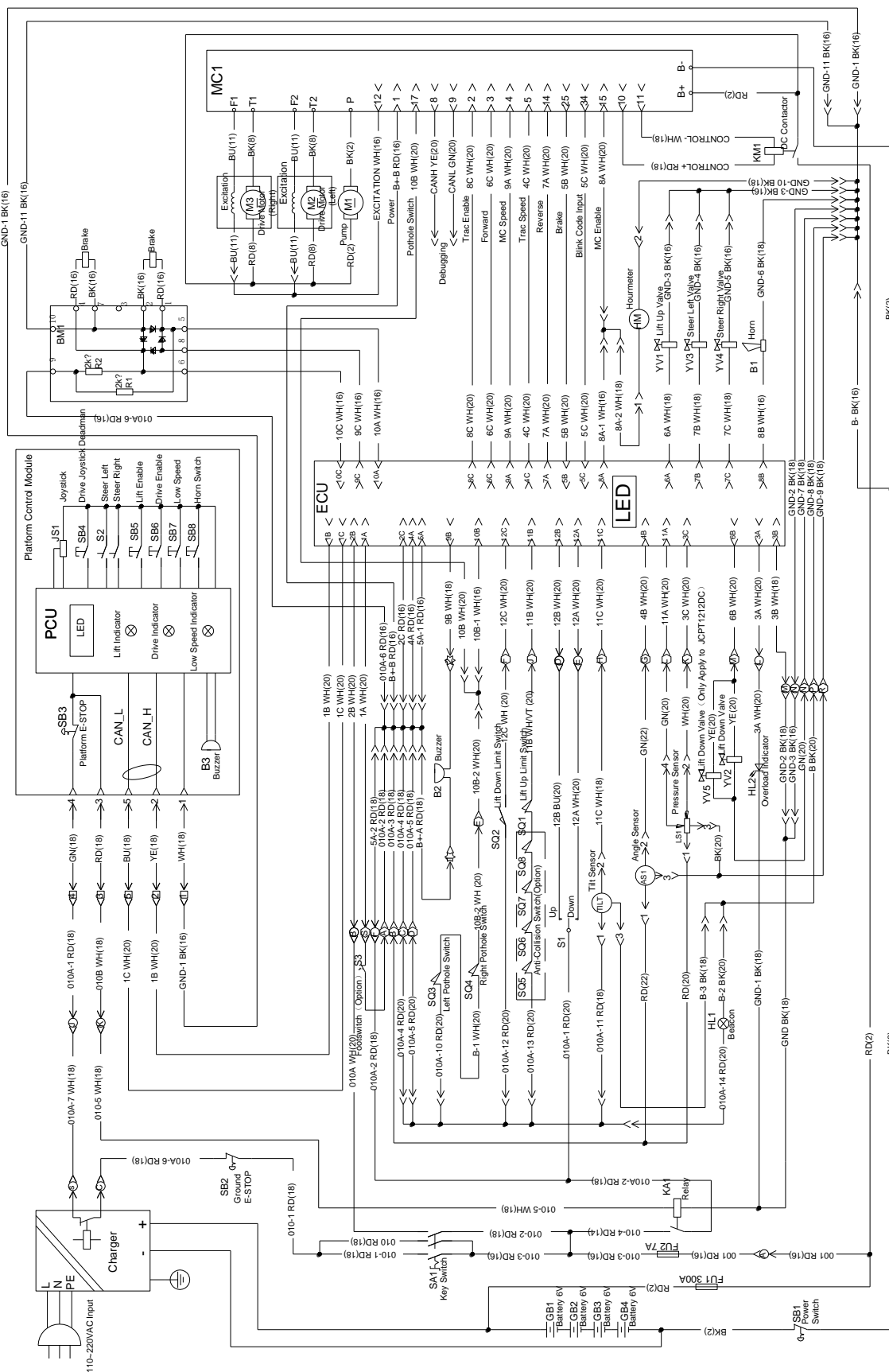

<16 Position DELPHI Connector LOC2
 <2 Position AMP Connector LOC4
 <16 Position DELPHI Connector LOC3
 <5 Position SIBAS Connector LOC7

JCPT1412DC JCPT1612DCB JCPT1612DCS

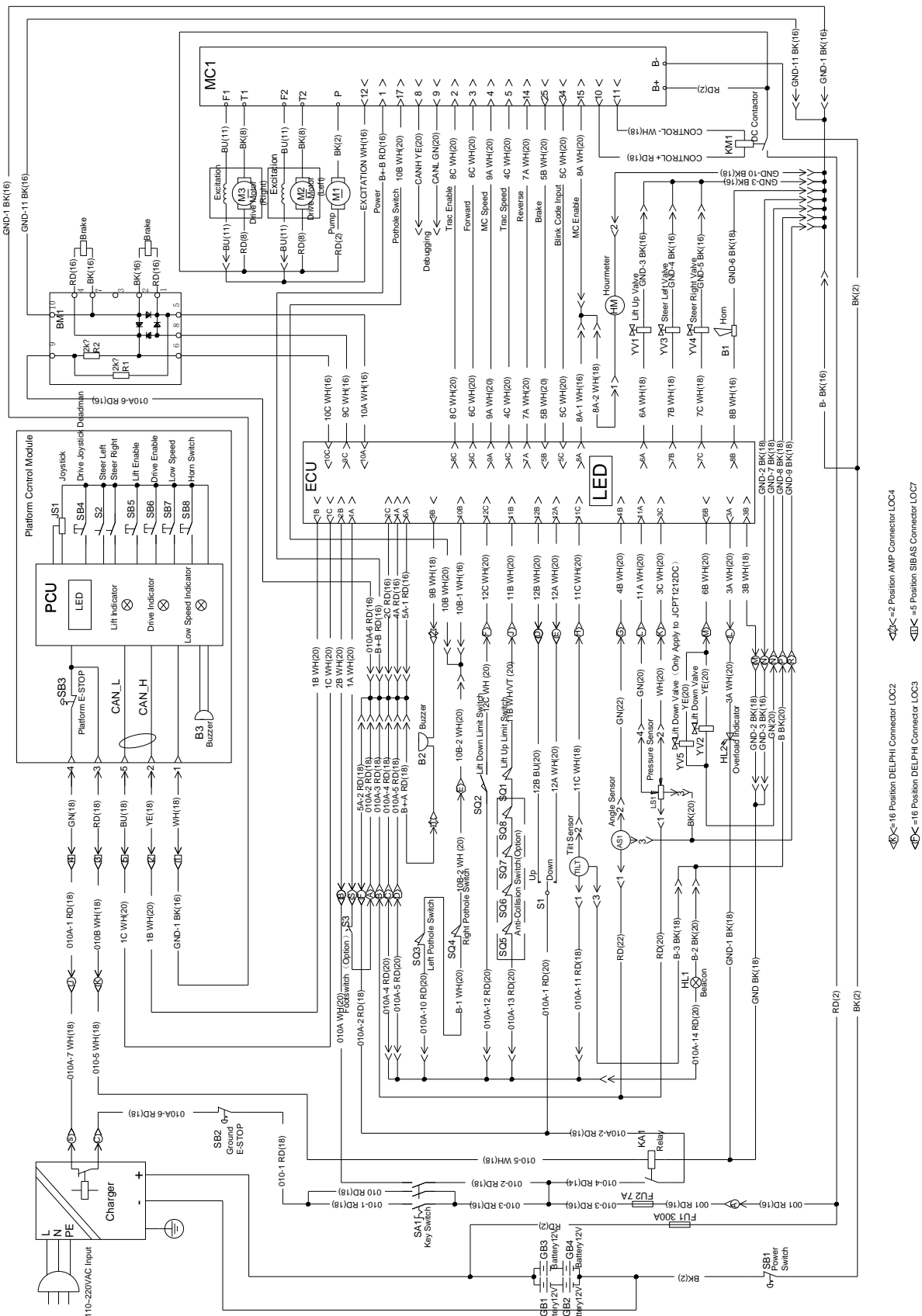

◀-16 Position DELPHI Connector, LOC2
 ◀-2 Position AMP Connector, LOC4
 ◀-16 Position DELPHI Connector, LOC3
 ◀-6 Position SIBAS Connector, LOC7

