

# SELF-PROPELLED SCISSOR LIFTS

# OPERATOR'S MANUAL

*with Maintenance Information*

JCPT0807HA/AC JCPT0808HA/AC JCPT0812HA/AC JCPT1008HA/AC

JCPT1012HA/AC JCPT1212HA/AC JCPT1412HA/AC JCPT1612HA/AC

JCPT1612HAS/ACS

(Hydraulic Motor Drive / Electric Motor Drive)



## WARNING

THE MANUFACTURER SHALL NOT BE HELD LIABLE IN CASE OF FAULTS OR ACCIDENTS DUE TO NEGLIGENCE, INCAPACITY, INSTALLATION BY UNQUALIFIED TECHNICIANS AND IMPROPER USE OF THE MACHINE

DO NOT OPERATE THIS MACHINE UNTIL YOU READ AND UNDERSTAND ALL THE DANGERS, WARNINGS AND CAUTIONS IN THIS MANUAL

Part Number: SM0120117\_Rev3.1



Zhejiang Dingli Machinery Co., Ltd.

Third Edition, May 2021 Printing

## Version of the Record

### Version of the Record

<b>Version Number</b>	<b>Create Date</b>
SM0120117_Rev1.0 .....	2020-07
SM0120117_Rev2.0 .....	2020-12
SM0120117_Rev2.1 .....	2021-01
SM0120117_Rev3.0 .....	2021-06
SM0120117_Rev3.1 .....	2021-10



## Important

Read, understand and obey these safety rules and operating instructions before operating this machine.

Only trained and authorized personnel shall be permitted to operate this machine. This manual should be considered a permanent part of your machine and should remain with the machine at all times. If you have any questions, please call DINGLI Machinery.

## Contents

---

	Page
Safety Rules	1
Legend	11
Decals	12
Specifications	21
Control panel	41
Pre-operation Inspection	44
Workplace Inspection	46
Function Tests	47
Operating Instructions	53
Transport and Lifting Instructions	68
Storage	72
Maintenance	74
Schematic	98
Inspection and Repair Log	112

---

## Owners, Users and operators:

We appreciate your choice of our machine for your application. Our number one priority is user safety, which is best achieved by our joint efforts. We feel that you make a major contribution to safety if you, as the equipment users and operators:

- 1 Comply with employer, job site and governmental rules.
- 2 Read, understand and follow the instructions in this and other manuals supplied with this machine.
- 3 Use good safe work practices in a commonsense way.
- 4 Only have trained / certified operators, directed by informed and knowledgeable supervision, running the machine.

If there is anything in this manual that is not clear or which you believe should be added, please contact us.

---

## Contact us:

---

### Zhejiang Dingli Machinery Co., Ltd.

1255 Baiyun South Road. Leidian Town.  
Deqing Zhejiang

China

Tel: +86-572-8681688

Fax: +86-572-8681690

Web: [www.cndingli.com](http://www.cndingli.com)

E-mail: [market@cndingli.com](mailto:market@cndingli.com)



## Safety Rules



### Danger

Failure to obey the instructions and safety rules in this manual will result in death or serious injury.

### Do Not Operate Unless:

- You learn and practice the principles of safe machine operation contained in this operator's manual.
  - 1 Avoid hazardous situations.**
  - Know and understand the safety rules before going on to the next section.**
  - 2 Always perform a pre-operation inspection.
  - 3 Always perform function tests prior to use.
  - 4 Inspect the workplace.
  - 5 Only use the machine as it was intended.
- You read, understand and obey the manufacturer's instructions and safety rules — operator's manual and machine decals.
- You read, understand and obey employer's safety rules and worksite regulations.
- You read, understand and obey all applicable governmental regulations.
- You are properly trained to safely operate the machine.

### Decal Legend

DINGLI product decals use symbols, color coding and signal words to identify the following:



**Safety alert symbol** — used to alert personnel to potential personal injury hazards. Obey all safety messages that follow this symbol to avoid possible injury or death.



**DANGER** Red — used to indicate the presence of an imminently hazardous situation which, if not avoided, will result in death or serious injury.



**WARNING** Orange — used to indicate the presence of a potentially hazardous situation which, if not avoided, could result in death or serious injury.



**CAUTION** Yellow with safety alert symbol — used to indicate the presence of a potentially hazardous situation which, if not avoided, may cause minor or moderate injury.



**NOTICE** Blue without safety alert symbol — used to indicate the presence of a potentially hazardous situation which, if not avoided, may result in property damage.

## Safety Rules

### The relevant conditions of using the equipment

The surface of work ground should be flat and hard with no obstacles in air and the safety distance between the equipment and high-tension line is adequate.

The environment temperature should be within  $-20^{\circ}\text{C}\sim 40^{\circ}\text{C}$ ; Height above sea level  $\leq 1000\text{m}$ .

The environment humidity  $\leq 90\%$ .

Electrical power: AC  $110\sim 230\text{V}\pm 10\%$ ,  $50\sim 60\text{Hz}$ .

applicable governmental regulations and the following chart.

Voltage Phase to Phase	Minimum Safe Approach Distance Meters
0 to 300V	Avoid Contact
300V to 50kV	3.05
50kV to 200kV	4.60
200kV to 350kV	6.10
350kV to 500kV	7.62
500kV to 750kV	10.67
750kV to 1000kV	13.72

### Intended Use

This machine is intended to be used only to lift personnel, along with their tools and materials to an aerial work site.

### Safety Sign Maintenance

Replace any missing or damaged safety signs. Keep operator safety in mind at all times.

Use mild soap and water to clean safety signs.

Do not use solvent-based cleaners because they may damage the safety sign material.

Allow for platform movement, electrical line sway or sag and beware of strong or gusty winds.

Keep away from the machine if it contacts energized power lines. Personnel on the ground or in the platform must not touch or operate the machine until energized power lines are shut off.

Do not operate the machine during lightning or storms.

Do not use the machine as a ground for welding.

### ⚠️ Electrocutation Hazard

This machine is not electrically insulated and will not provide protection from contact with or proximity to electrical current.

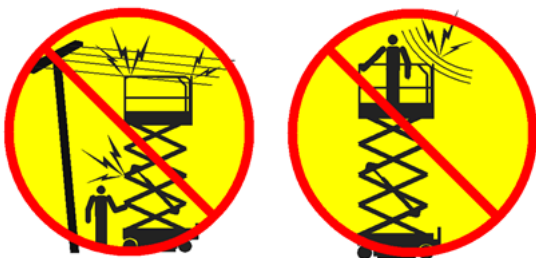

Maintain safe distances from electrical power lines and apparatus in accordance with

### ⚠️ Tip-over Hazard

Occupants, equipment and materials must not exceed the maximum platform capacity or the maximum capacity of the platform extension.

#### Maximum capacity – JCPT0807HA

Maximum occupants (Indoor use)	2
Maximum occupants (Outdoor use)	1
Platform allowable maximum load	230kg
Extension deck allowable maximum load	113kg

#### Maximum capacity – JCPT0808HA

Maximum occupants (Indoor use)	2
--------------------------------	---

## Safety Rules

Maximum occupants (Outdoor use) 1

Platform allowable maximum load 380kg

Extension deck allowable maximum load 113kg

### Maximum capacity – JCPT0812HA

Maximum occupants (Indoor / Outdoor use) 2

Platform allowable maximum load 540kg

Extension deck allowable maximum load 113kg

### Maximum capacity – JCPT1008HA

Maximum occupants (Indoor use **ONLY**) 2

Platform allowable maximum load 230kg

Extension deck allowable maximum load 113kg

### Maximum capacity – JCPT1012HA

Maximum occupants (Indoor / Outdoor use) 2

Platform allowable maximum load 450kg

Extension deck allowable maximum load 113kg

### Maximum capacity – JCPT1212HA

Maximum occupants (Indoor use) 2

Maximum occupants (Outdoor use) 1

Platform allowable maximum load 320kg

Extension deck allowable maximum load 113kg

### Maximum capacity – JCPT1412HA

Maximum occupants (Indoor use **ONLY**) 3

Platform allowable maximum load 320kg

Extension deck allowable maximum load 113kg

### Maximum capacity – JCPT1612HA

Maximum occupants (Indoor use **ONLY**) 2

Platform allowable maximum load 250kg

Extension deck allowable maximum load 113kg

### Maximum capacity – JCPT1612HAS

Maximum occupants (Indoor use **ONLY**) 2

Platform allowable maximum load 250kg

Extension deck allowable maximum load 113kg

### Maximum capacity – JCPT0807AC

Maximum occupants (Indoor use) 2

Maximum occupants (Outdoor use) 1

Platform allowable maximum load 230kg

Extension deck allowable maximum load 113kg

### Maximum capacity – JCPT0808AC

Maximum occupants (Indoor use) 2

Maximum occupants (Outdoor use) 1

Platform allowable maximum load 380kg

Extension deck allowable maximum load 113kg

### Maximum capacity – JCPT0812AC

Maximum occupants (Indoor/Outdoor use) 2

Platform allowable maximum load 540kg

Extension deck allowable maximum load 113kg

### Maximum capacity – JCPT1008AC

Maximum occupants (Indoor use **ONLY**) 2

Platform allowable maximum load 230kg

Extension deck allowable maximum load 113kg

### Maximum capacity – JCPT1012AC

Maximum occupants (Indoor/Outdoor use) 2

Platform allowable maximum load 450kg

Extension deck allowable maximum load 113kg

### Maximum capacity – JCPT1212AC

Maximum occupants (Indoor use) 2

Maximum occupants (Outdoor use) 1

Platform allowable maximum load 320kg

Extension deck allowable maximum load 113kg

### Maximum capacity – JCPT1412AC

Maximum occupants (Indoor use **ONLY**) 3

Platform allowable maximum load 320kg

Extension deck allowable maximum load 113kg

### Maximum capacity – JCPT1612AC



## Safety Rules

Maximum occupants (Indoor use **ONLY**) 2  
 Platform allowable maximum load 250kg  
 Extension deck allowable maximum load 113kg

### Maximum capacity – JCPT1612ACS

Maximum occupants (Indoor use **ONLY**) 2  
 Platform allowable maximum load 250kg  
 Extension deck allowable maximum load 113kg

Platform retracted



Platform extended



Extension only      Platform only

## Work Area Safety

Do not raise the platform unless the machine is on a firm, level surface.

Do not drive over 0.8 km/h with the platform raised.



Do not depend on the tilt alarm as a level indicator. The tilt alarm sounds on the chassis and in the platform when the machine is on a slope.

If the tilt alarm sounds:

Lower the platform. Move the machine to a firm, level surface. If the tilt alarm sounds when the platform is raised, use extreme caution to lower the platform.

For outdoor use machine, do not raise the platform when wind speeds may exceed 12.5 m/s. If wind speeds exceed 12.5 m/s when the

platform is raised, lower the platform and do not continue to operate the machine.

Do not operate the machine in strong or gusty winds. Do not increase the surface area of the platform or the load. Increasing the area exposed to the wind will decrease machine stability.



Do not use the platform controls to free a platform that is caught, snagged or otherwise prevented from normal motion by an adjacent structure. All personnel must be removed from the platform before attempting to free the platform using the ground controls.

Use extreme care and slow speeds while driving the machine in the stowed position across uneven terrain, debris, unstable or slippery surfaces and near holes and drop-offs.

Do not drive the machine on or near uneven terrain, unstable surfaces or other hazardous conditions with the platform raised.

Do not push off or pull toward any object outside of the platform.



## Safety Rules

### Maximum allowable manual force

Model	Application	manual force	Maximum occupants
JCPT0807HA	Outdoor	200N	1
	Indoor	400N	2
JCPT0808HA	Outdoor	200N	1
	Indoor	400N	2
JCPT0812HA	Outdoor	400N	2
	Indoor	400N	2
JCPT1008HA	Indoor	400N	2
JCPT1012HA	Outdoor	400N	2
	Indoor	400N	2
JCPT1212HA	Outdoor	200N	1
	Indoor	400N	2
JCPT1412HA	Indoor	400N	3
JCPT1612HA	Indoor	400N	2
JCPT1612HAS	Indoor	400N	2
JCPT0807AC	Outdoor	200N	1
	Indoor	400N	2
JCPT0808AC	Outdoor	200N	1
	Indoor	400N	2
JCPT0812AC	Outdoor	400N	2
	Indoor	400N	2
JCPT1008AC	Indoor	400N	2
JCPT1012AC	Outdoor	400N	2
	Indoor	400N	2
JCPT1212AC	Outdoor	200N	1
	Indoor	400N	2
JCPT1412AC	Indoor	400N	3
JCPT1612AC	Indoor	400N	2
JCPT1612ACS	Indoor	400N	2

Do not use the machine as a crane.

Do not place or attach fixed or overhanging loads to any part of this machine.

Do not push the machine or other objects with the platform.

Do not operate the machine with the chassis trays open.

Do not contact adjacent structures with the platform.

Do not alter or disable the limit switches.

Do not tie the platform to adjacent structures.

Do not place loads outside the platform perimeter.



Do not alter or disable machine components that in any way affect safety and stability.

Do not replace items critical to machine stability with items of different weight or specification.

Do not use batteries that weigh less than the original equipment. Batteries are used as counterweight and are critical to machine stability.

The lithium battery: The battery must weigh a minimum of 50 kg. (For JCPT0807HA/AC, JCPT0808HA/AC, JCPT0812HA/AC, JCPT1008HA/AC, and JCPT1012HA/AC); the battery must weigh a minimum of 62 kg. (For JCPT1212HA/AC, JCPT1412HA/AC, and JCPT1612HA/AC, JCPT1612HAS/ACS).

The lead-acid battery: Each battery must weigh 28 kg. The batteries must weigh a minimum of 112 kg. (For JCPT0807HA/AC, JCPT0808HA/AC, JCPT0812HA/AC, JCPT1008HA/AC, JCPT1012HA/AC); Each battery must weigh 30 kg. The batteries must weigh a minimum of 120 kg (For JCPT1212HA/AC); Each battery must weigh

## Safety Rules

37 kg. The batteries must weigh a minimum of 148 kg (For JCPT1412HA/AC, JCPT1612HA/AC, JCPT1612HAS/ACS).

Do not modify or alter an aerial work platform without prior written permission from the manufacturer. Mounting attachments for holding tools or other materials onto the platform, toe boards or guard rail system can increase the weight in the platform and the surface area of the platform or the load.

Do not place ladders or scaffolds in the platform or against any part of this machine.

Do not transport tools and materials unless they are evenly distributed and can be safely handled by person(s) in the platform.

Do not use the machine on a moving or mobile surface or vehicle.

Be sure all tires are in good condition, air-filled tires are properly inflated and lug nuts are properly tightened.

### **▲ Crushing Hazard**

Keep hands and limbs out of scissors.

Keep hands clear when folding rails.

Maintain a firm grasp on the platform rail when removing the rail pins. Do not allow the platform guard rails to fall.

Use common sense and planning when operating the machine with the controller from the ground. Maintain safe distances between the operator, the machine and fixed objects.

### **▲ Operation on Slopes Hazard**

Do not drive the machine on a slope that exceeds the slope and side slope rating of the machine.

Slope rating applies to machines only in the stowed position.



Maximum slope rating stowed

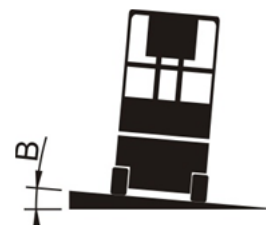

Maximum side slope rating stowed

Model	A	B
JCPT0807HA	25% (14°)	25% (14°)
JCPT0808HA	25% (14°)	25% (14°)
JCPT0812HA	25% (14°)	25% (14°)
JCPT1008HA	25% (14°)	25% (14°)
JCPT1012HA	25% (14°)	25% (14°)
JCPT1212HA	25% (14°)	25% (14°)
JCPT1412HA	25% (14°)	25% (14°)
JCPT1612HA	25% (14°)	25% (14°)
JCPT1612HAS	25% (14°)	25% (14°)
JCPT0807AC	25% (14°)	25% (14°)
JCPT0808AC	25% (14°)	25% (14°)
JCPT0812AC	25% (14°)	25% (14°)
JCPT1008AC	25% (14°)	25% (14°)
JCPT1012AC	25% (14°)	25% (14°)
JCPT1212AC	25% (14°)	25% (14°)
JCPT1412AC	25% (14°)	25% (14°)
JCPT1612AC	25% (14°)	25% (14°)
JCPT1612ACS	25% (14°)	25% (14°)

## Safety Rules

Note: Slope rating is subject to ground conditions and adequate traction.

### ▲ Fall Hazard

The guard rail system provides fall protection. If occupant(s) of the platform are required to wear personal fall protection equipment (PFPE) due to job site or employer rules, PFPE equipment and its use shall be in accordance with the PFPE manufacturer's instructions and applicable governmental requirements.

Do not sit, stand or climb on the platform guard rails. Maintain a firm footing on the platform floor at all times.



Do not climb down from the platform when raised.

Keep the platform floor clear of debris.

Close the entry gate before operating.

Do not operate the machine unless the guard rails are properly installed and the entry is secured for operation.

Do not enter or exit the platform unless the machine is in the stowed position.

### ▲ Collision Hazard



Be aware of limited sight distance and blind spots when driving or operating.

Be aware of extended platform position(s) when moving the machine.

Check the work area for overhead obstructions or other possible hazards.



Be aware of crushing hazards when grasping the platform guard rail.

Operators must comply with employer, job site and governmental rules regarding use of personal protective equipment.

Observe and use color-coded direction arrows on the platform controls for drive and steer functions.

Do not operate a machine in the path of any crane or moving overhead machinery unless the controls of the crane have been locked out and/or precautions have been taken to prevent any potential collision.

No stunt driving or horseplay while operating a machine.

Do not lower the platform unless the area below is clear of personnel and obstructions.



Limit travel speed according to the condition of the ground surface, congestion, slope, location of personnel, and any other factors which may cause collision.

### ▲ Component Damage Hazard

Do not use any battery charger greater than 24V to charge the batteries.

## Safety Rules

The charger must match the battery. The lithium battery cannot be charged by the lead-acid battery charger. The lead-acid battery cannot be charged by the lithium battery charger.

Do not use the machine as a ground for welding.

### ⚠ Explosion and Fire Hazard

Do not operate the machine or charge the batteries in hazardous locations where potentially flammable or explosive gases or particles may be present.

### ⚠ Damaged Machine Hazard

Do not use a damaged or malfunctioning machine.

Conduct a thorough pre-operation inspection of the machine and test all functions before each work shift. Immediately tag and remove from service a damaged or malfunctioning machine.

Be sure all maintenance has been performed as specified in this manual.

Be sure all decals are in place and legible.

Be sure the operator's manual is complete, legible and in the storage container located in the platform.

### ⚠ Bodily Injury Hazard

Do not operate the machine with a hydraulic oil or air leak. An air leak or hydraulic leak can penetrate and/or burn skin.

Improper contact with components under any cover will cause serious injury. Only trained maintenance personnel should access compartments. Access by the operator is only advised when performing a pre-operation inspection. All compartments must remain

closed and secured during operation.

### ⚠ Battery Safety

#### ⚠ Burn Hazard



Batteries contain acid. Always wear protective clothing and eye wear when working with batteries.

Avoid spilling or contacting battery acid. Neutralize battery acid spills with baking soda and water.

Rinse eyes or skin splashed with acid using plenty of clean water and consult a doctor immediately. Wash clothing contaminated with acid with plenty of water.

If the lithium battery local fire, can be buried in sand, such as hot gas, it needs a lot of water foam to cool treatment.

#### ⚠ Explosion Hazard



Keep sparks, flames and lighted tobacco away from batteries. Batteries emit explosive gas.

Avoid fire and risk of explosion caused by short circuits.

The battery tray should remain open during the entire charging cycle.

Do not contact the battery terminals or the cable clamps with tools that may cause sparks.

#### ⚠ Component Damage Hazard

Do not use any battery charger greater than

## Safety Rules

24V to charge the batteries.

The charger must match the battery. The lithium battery cannot be charged by the lead-acid battery charger. The lead-acid battery cannot be charged by the lithium battery charger.

Pressure relief valves are used as breathable plugs. If open the pressure relief valves, the battery will be destroyed.

The battery must always be kept clean and dry in order to prevent leakage currents. Do not rinse with water or wipe with a wet towel.

Please do not change the location of the battery, and cannot be inverted. Do not block the vent hole of safety valve when placing.

Do not attempt to open or modify the battery in any way.

The series/parallel connection must be approved by Dingli. Only accessories approved by Dingli can be used for connection of battery blocks.

### ▲ Electrocuting/ Burn Hazard



Connect the battery charger to a grounded, AC 3-wire electrical outlet only.

Inspect daily for damaged cords, cables and wires.

Replace damaged items before operating.

Metallic parts of the battery cells are always electriferous. Therefore, no foreign objects or tools may be placed on the batteries.

Avoid electrical shock from contact with battery terminals. Remove all rings, watches and other jewelry.

If the battery terminal is to be touched, it should be operated with insulating gloves to prevent the risk of high voltage electric shock.

### ▲ Tip-over Hazard

Do not use batteries that weigh less than the original equipment. Batteries are used as

counterweight and are critical to machine stability.

The lithium battery: The battery must weigh a minimum of 50 kg. (For JCPT0807HA/AC, JCPT0808HA/AC, JCPT0812HA/AC, JCPT1008HA/AC, and JCPT1012HA/AC); the battery must weigh a minimum of 62 kg. (For JCPT1212HA/AC, JCPT1412HA/AC, and JCPT1612HA/AC, JCPT1612HAS/ACS).

The lead-acid battery: Each battery must weigh 28 kg. The batteries must weigh a minimum of 112 kg. (For JCPT0807HA/AC, JCPT0808HA/AC, JCPT0812HA/AC, JCPT1008HA/AC, JCPT1012HA/AC); Each battery must weigh 30 kg. The batteries must weigh a minimum of 120 kg (For JCPT1212HA/AC); Each battery must weigh 37 kg. The batteries must weigh a minimum of 148 kg (For JCPT1412HA/AC, JCPT1612HA/AC, JCPT1612HAS/ACS).

### ▲ Lifting Hazard

Use the appropriate number of people and proper lifting techniques when lifting hooks must not cause any damage to cells, connectors and connecting cables.

The lithium battery shall be operated smoothly in the process of handling and assembly, and collision and other impact phenomena are strictly prohibited.

### ▲ Environmental Hazard

30°C battery temperature is considered the rated temperature. Higher temperatures reduce the service life, while lower temperatures reduce the available capacity. 45°C is the upper limit temperature and is not permissible as an operating temperature.

The rated temperature range of lithium battery is -30°C ~ 55°C. If it is found that the temperature of the battery exceeds 60°C during use, the battery should be stopped

## Safety Rules

immediately and put aside separately.

Batteries must not be exposed to sunlight without protection.

### **▲ Transportation and storage**

#### **Hazard**

Charge the battery as soon as receive the machine or after long distance transportation

When the battery is stored for a long time, it needs to be charged regularly. Failure to charge in time may permanently damage the battery.

### **▲ pollute Hazard**



Old batteries with this marking are recyclable goods and must be sent for recycling.

Used batteries which are not sent for recycling are to be disposed of as special waste under the relevant regulations.

## Lockout after Each Use

- 1 Select a safe parking location - firm level surface, clear of obstruction and traffic.
- 2 Lower the platform.
- 3 Turn the key switch to the off position and remove the key to secure from unauthorized use.
- 4 Push in the red Emergency Stop buttons to "off" position.
- 5 Push in the main power switch to "off" position
- 6 Chock the wheels.
- 7 Charge the batteries.

**Legend**

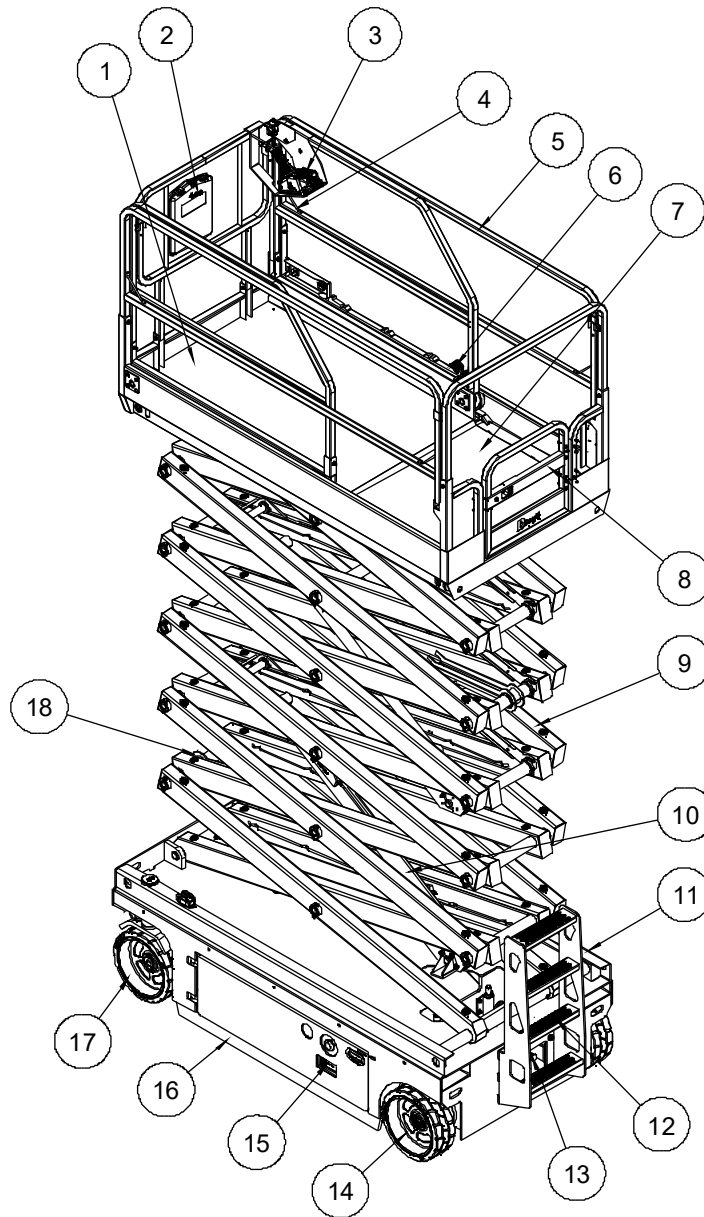

- |                                    |  |
|------------------------------------|--|
| 1 Platform extension               | 10 Lift cylinder                                 |
| 2 Manual storage container         | 11 Ground controls (on opposite side of machine) |
| 3 Platform control                 | 12 Entry ladder                                  |
| 4 Lanyard anchorage point          | 13 Brake release pump                            |
| 5 Platform guard rails             | 14 Non-steer tire                                |
| 6 Platform extension release pedal | 15 Battery charger                               |
| 7 Main platform                    | 16 Pothole guard                                 |
| 8 Platform entry gate              | 17 Steer tire                                    |
| 9 Scissor arms                     | 18 Safety arm                                    |



## Decals

### Decal Inspection

Use the pictures on the next page to verify that all decals are legible and in place.

Below is a numerical list with quantities and descriptions.

#### JCPT0807HA/AC

No.	Part No.	Description	Qty.	Remark
1	09440011	Decal, Label-Lanyard anchorage point	4	
2	09340001	Decal, Notice-Keep the manual with the machine	1	
3	09440003	Decal, Danger-Tip-over hazard, tilt-alarm	1	
4	09440001	Decal, Danger-General safety rules	1	
5	09340003	Decal, Instructions-Refer the operator to the instructions for use	2	
6	09440070	Decal, Label-Capacity 230kg	1	
7	09310001	Decal, Instructions-Forklift pockets	2	
8	09310003	Decal, Instructions-Tie down point	4	
9	09310002	Decal, Instructions-Lift point	4	
10	09310233	Decal, Instructions-Maximum wheel load 710kg	4	
11	09310064	Decal, Notice-Main power switch operation	1	
12	09540001	Decal, Label-CE	3	
13	09410129	Decal, Warning-Charge warning	1	
14	09410001	Decal, Danger-Explosion/burn hazard	1	
15	09330001	Decal, Danger-Safety arm	2	
16	09440009	Decal, Caution-Max. manual force 400N (Indoor) 200N (Outdoor)	2	
17	09640123	Decal, Label-JCPT0807HA	2	
	09640122	Decal, Label-JCPT0807AC	2	
18	09410005	Decal, Danger-Do not alter or disable limit switch	1	
19	09430003	Decal, Danger-Keep away from moving parts	1	
20	09310004	Decal, Instructions-Emergency lower	1	
21	09410003	Decal, Warning-Inspected and operation properly	1	

JCPT0807HA/AC

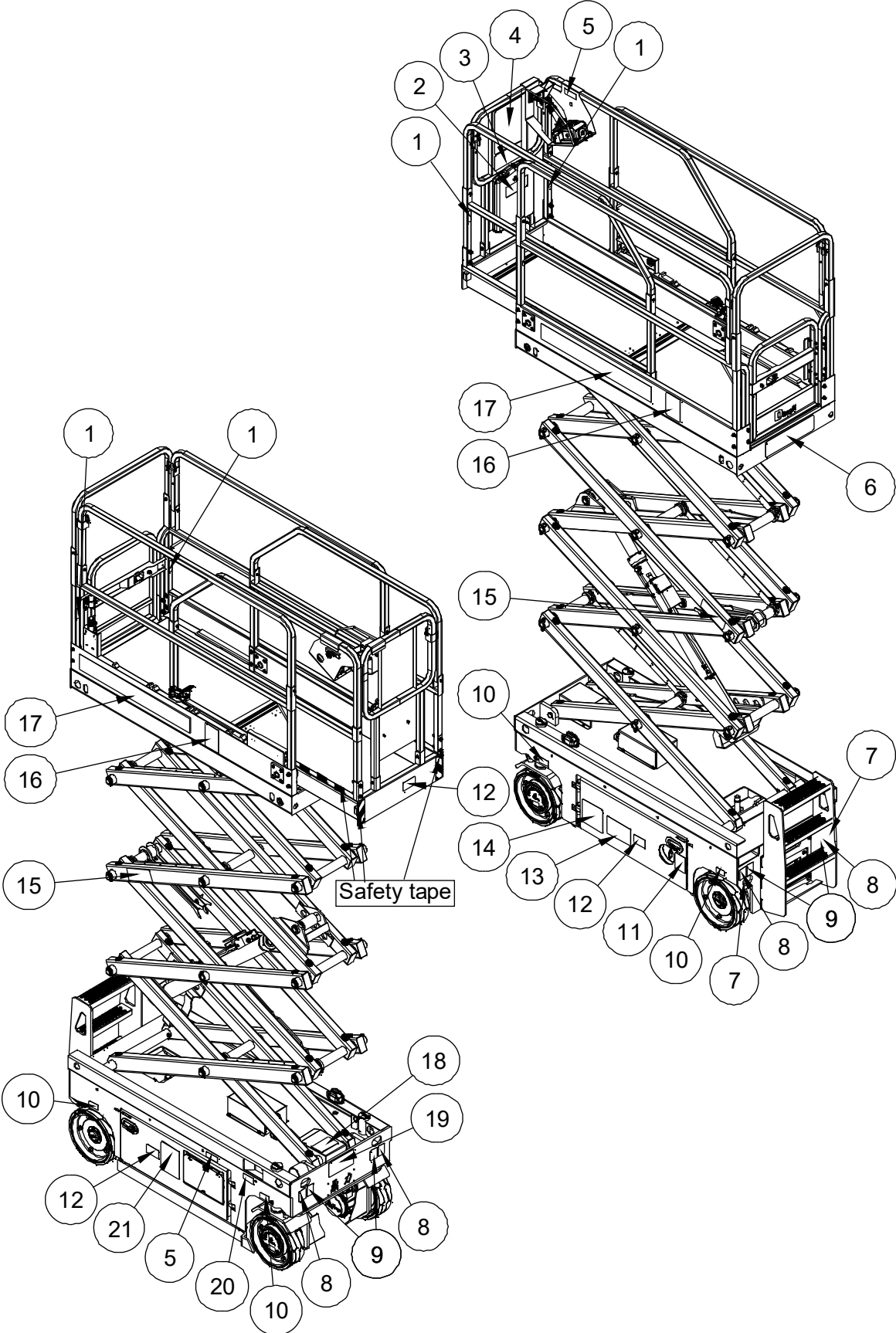



# Decals

## JCPT0807HA/AC

① 09440011 

② 09340001 

③ 09440003 

④ 09440001 

⑤ 09340003 

⑥ 09440070 

⑦ 09310001 

⑧ 09310003 

⑨ 09310002 

⑩ 09310233 

⑪ 09310064 

⑫ 09540001 

⑬ 09410129 

⑭ 09410001 

⑮ 09330001 

⑯ 09430003 

⑰ 09640123 

⑰ 09640122 

⑱ 09410005 

⑳ 09310004 

㉑ 09410003 

㉒ 09440009 

**Decals****JCPT0808HA/AC~ JCPT1612HAS/ACS**

No.	Part No.	Description	Qty.	Remark
1	09440011	Decal, Label-Lanyard anchorage point	4	
2	09340001	Decal, Notice-Keep the manual with the machine	1	
3	09440001	Decal, Danger-General safety rules	1	
4	09440003	Decal, Danger-Tip-over hazard, tilt-alarm	1	
5	09340003	Decal, Instructions-Refer the operator to the instructions for use	2	
6	09440013	Decal, Label-Capacity 380kg	1	JCPT0808HA/AC
	09440300	Decal, Label-Capacity 450kg	1	JCPT0812HA/AC
	09440014	Decal, Label-Capacity 230kg	1	JCPT1008HA/AC
	09440015	Decal, Label-Capacity 450kg	1	JCPT1012HA/AC
	09440016	Decal, Label-Capacity 320kg	1	JCPT1212HA/AC
	09440017	Decal, Label-Capacity 320kg	1	JCPT1412HA/AC
	09440038	Decal, Label-Capacity 250kg	1	JCPT1612HA/AC, JCPT1612HAS/ACS
7	09440005	Decal, Warning-Use indoors only	1	JCPT1008HA/AC, JCPT1412HA/AC, JCPT1612HA/AC, JCPT1612HAS/ACS
8	09430003	Decal, Danger-Keep away from moving parts	3	JCPT0808HA/AC, JCPT0812HA/AC, JCPT1008HA/AC, JCPT1012HA/AC, JCPT1212HA/AC
	09430003	Decal, Danger-Keep away from moving parts	5	JCPT1412HA/AC, JCPT1612HA/AC, JCPT1612HAS/ACS
9	09430001	Decal, Danger-Safety arm	2	JCPT0808HA/AC, JCPT0812HA/AC, JCPT1008HA/AC, JCPT1012HA/AC, JCPT1212HA/AC
	09430001	Decal, Danger-Safety arm	4	JCPT1412HA/AC, JCPT1612HA/AC, JCPT1612HAS/ACS
10	09310001	Decal, Instructions-Forklift pockets	2	
11	09310003	Decal, Instructions-Tie down point	4	

## Decals

No.	Part No.	Description	Qty.	Remark
12	09310002	Decal, Instructions-Lift point	4	
13	09310008	Decal, Instructions-Maximum wheel load 1000kg	4	JCPT0808HA/AC, JCPT0812HA/AC
	09310010	Decal, Instructions-Maximum wheel load 960kg	4	JCPT1008HA/AC
	09310012	Decal, Instructions-Maximum wheel load 1240kg	4	JCPT1012HA/AC
	09310014	Decal, Instructions-Maximum wheel load 1310kg	4	JCPT1212HA/AC
	09310016	Decal, Instructions-Maximum wheel load 1280kg	4	JCPT1412HA/AC
	09310018	Decal, Instructions-Maximum wheel load 1350kg	4	JCPT1612HA/AC, JCPT1612HAS/ACS
14	09310006	Decal, Notice-Main power switch operation	1	
15	09540001	Decal, Label-CE	3	
16	09410129	Decal, Warning-Charge warning	1	
17	09410001	Decal, Danger-Explosion/burn hazard	1	
18	09440009	Decal, Caution-Max. manual force 400N Indoor 200N Outdoor	2	JCPT0808HA/AC, JCPT1212HA/AC
	09440007	Decal, Caution-Max. manual force 400N	2	JCPT0812HA/AC, JCPT1008HA/AC, JCPT1012HA/AC, JCPT1412HA/AC, JCPT1612HA/AC, JCPT1612HAS/ACS
19	09640124	Decal, Cosmetic-JCPT0808HA	2	JCPT0808HA
	09640125	Decal, Cosmetic-JCPT0808AC	2	JCPT0808AC
	09640121	Decal, Cosmetic-JCPT0812HA	2	JCPT0812HA
	09640120	Decal, Cosmetic-JCPT0812AC	2	JCPT0812AC
	09640126	Decal, Cosmetic-JCPT1008HA	2	JCPT1008HA
	09640127	Decal, Cosmetic-JCPT1008AC	2	JCPT1008AC
	09640128	Decal, Cosmetic-JCPT1012HA	2	JCPT1012HA
	09640129	Decal, Cosmetic-JCPT1012AC	2	JCPT1012AC
	09640130	Decal, Cosmetic-JCPT1212HA	2	JCPT1212HA
	09640131	Decal, Cosmetic-JCPT1212AC	2	JCPT1212AC
	09640132	Decal, Cosmetic-JCPT1412HA	2	JCPT1412HA

**Decals**

<b>No.</b>	<b>Part No.</b>	<b>Description</b>	<b>Qty.</b>	<b>Remark</b>
19	09640133	Decal, Cosmetic-JCPT1412AC	2	JCPT1412AC
	09640134	Decal, Cosmetic-JCPT1612HA	2	JCPT1612HA
	09640135	Decal, Cosmetic-JCPT1612AC	2	JCPT1612AC
	09640119	Decal, Cosmetic-JCPT1612HAS	2	JCPT1612HAS
	09640118	Decal, Cosmetic-JCPT1612ACS	2	JCPT1612ACS
20	09410005	Decal, Danger-Do not alter or disable limit switch	1	
21	09310004	Decal, Instructions-Emergency lower	1	
22	09410003	Decal, Warning-Inspected and operation properly	1	

# Decals

## JCPT0808HA/AC~ JCPT1612HAS/ACS

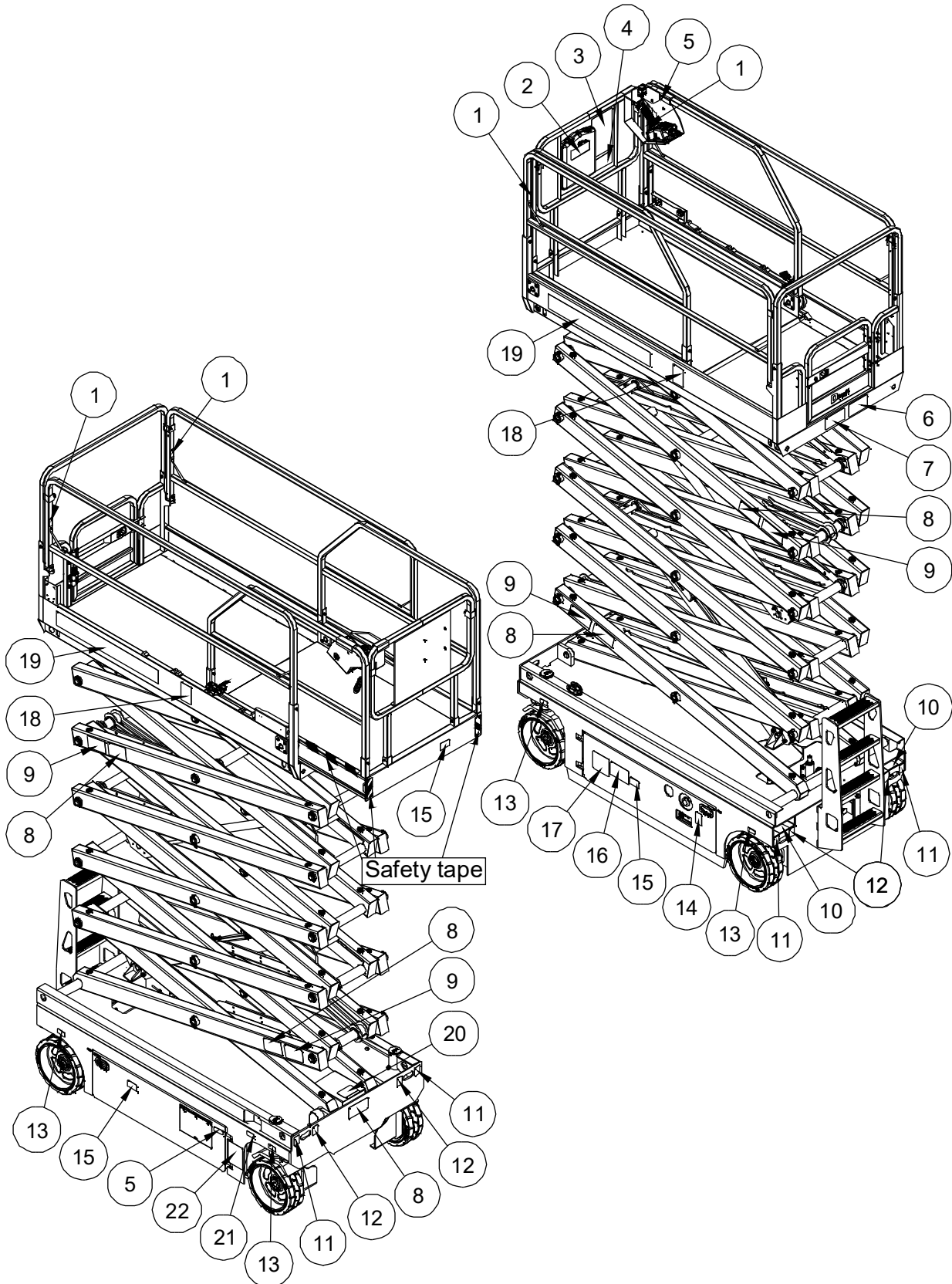

JCPT0808HA/AC~ JCPT1612HAS/ACS

① 09440011



② 09340001



③ 09440001



④ 09440003



⑤ 09340003



⑥ 09440013

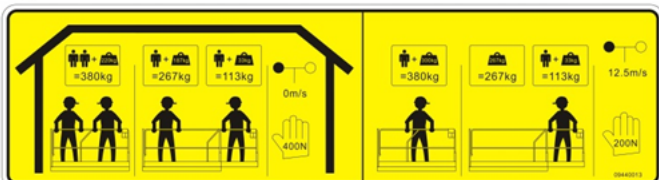

⑥ 09440015



⑥ 09440014



⑥ 09440016

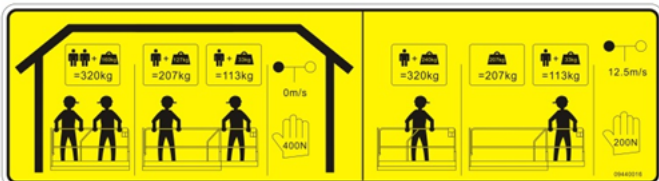

⑥ 09440017



⑥ 09440300



⑥ 09440038



⑦ 09440005



⑧ 09430003

















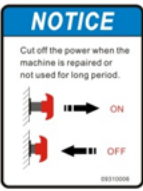

⑨ 09430001



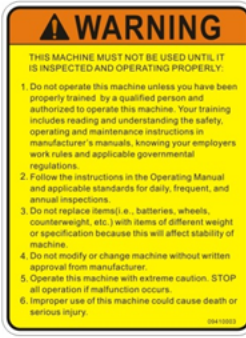

# Decals

## JCPT0808HA/AC~ JCPT1612HAS/ACS

<p>⑩ 09310001</p> 	<p>⑪ 09310003</p> 	<p>⑬ 09310008</p> 	<p>⑬ 09310014</p> 	<p>⑭ 09310006</p> 
	<p>⑫ 09310002</p> 	<p>⑬ 09310010</p> 	<p>⑬ 09310016</p> 	
		<p>⑬ 09310012</p> 	<p>⑬ 09310018</p> 	<p>⑮ 09540001</p> 
<p>⑲ 09640124</p> <p><b>JCPT0808HA</b></p>	<p>⑰ 09410129</p> 	<p>⑱ 09440007</p> 		
<p>⑲ 09640125</p> <p><b>JCPT0808AC</b></p>	<p>⑰ 09410001</p> 	<p>⑱ 09440009</p> 		
<p>⑲ 09640121</p> <p><b>JCPT0812HA</b></p>	<p>⑳ 09410003</p> 	<p>㉑ 09410005</p> 		
<p>⑲ 09640120</p> <p><b>JCPT0812AC</b></p>		<p>㉑ 09310004</p> 		
<p>⑲ 09640126</p> <p><b>JCPT1008HA</b></p>				
<p>⑲ 09640127</p> <p><b>JCPT1008AC</b></p>				
<p>⑲ 09640128</p> <p><b>JCPT1012HA</b></p>				
<p>⑲ 09640129</p> <p><b>JCPT1012AC</b></p>				
<p>⑲ 09640130</p> <p><b>JCPT1212HA</b></p>				
<p>⑲ 09640131</p> <p><b>JCPT1212AC</b></p>				
<p>⑲ 09640132</p> <p><b>JCPT1412HA</b></p>				
<p>⑲ 09640133</p> <p><b>JCPT1412AC</b></p>				
<p>⑲ 09640134</p> <p><b>JCPT1612HA</b></p>	<p>⑲ 09640119</p> <p><b>JCPT1612HAS</b></p>			
<p>⑲ 09640135</p> <p><b>JCPT1612AC</b></p>	<p>⑲ 09640118</p> <p><b>JCPT1612ACS</b></p>			

**Specifications****Model: JCPT0807HA**

Height, working maximum	7.8 m	Maximum hydraulic pressure (functions)	180 bar
Height, platform maximum	5.8 m	System voltage	24 V
Height, stowed maximum Rails up	2.15 m	Tire size	Φ323×100 mm
Height, stowed maximum Rails folded	1.83 m	Airborne noise emissions	<70 dB
Width	0.76 m	Maximum sound level at normal operating workstations (A-weighted)	
Length, platform retracted	1.86 m	Vibration value does not exceed 2.5m/s <sup>2</sup>	
Length, platform extended	2.76 m	Maximum slope rating, Stowed position	25%
Platform dimensions (length × width)	1.67×0.74 m	Maximum side slope rating, Stowed position	25%
Platform extension length	0.9 m	Note: Slope rating is subject to ground conditions and adequate traction.	
Maximum load capacity	230 kg	Maximum working slope	X-1.5°, Y-3°
Maximum wind speed	12.5 m/s	<b>Drive speeds</b>	
Wheelbase	1.36 m	Stowed, maximum	4.0 km/h
Turning radius (outside)	1.64 m	Platform raised, maximum	0.6 km/h
Turning radius (inside)	0 m	<b>Floor loading information</b>	
Ground clearance	9 cm	Tire load, maximum	710kg
Ground clearance Pothole guards deployed	1.6 cm	Tire contact pressure	10.4kg/cm <sup>2</sup> 1019kPa
Weight (See Serial Label)		Occupied floor pressure	1373kg/m <sup>2</sup> 13.5kPa
Machine weights vary with option configurations		Note: Floor loading information is approximate and does not incorporate different option configurations. It should be used only with adequate safety factors.	
Controls	Proportional	Continuous improvement of our products is a DINGLI policy. Product specifications are subject to change without notice or obligation.	
AC outlet in platform	Standard		

## Specifications

### Model: JCPT0808HA

Height, working maximum	8 m	Maximum hydraulic pressure (functions)	240 bar
Height, platform maximum	6 m	System voltage	24 V
Height, stowed maximum Rails up	2.23 m	Tire size	Φ381×127 mm
Height, stowed maximum Rails folded	1.87 m	Airborne noise emissions	<70 dB
Width	0.83 m	Maximum sound level at normal operating workstations (A-weighted)	
Length, platform retracted	2.48 m	Vibration value does not exceed 2.5m/s <sup>2</sup>	
Length, platform extended	3.38 m	Maximum slope rating, Stowed position	25%
Platform dimensions (length × width)	2.27×0.81 m	Maximum side slope rating, Stowed position	25%
Platform extension length	0.9 m	Note: Slope rating is subject to ground conditions and adequate traction.	
Maximum load capacity	380 kg	Maximum working slope	X-1.5°,Y-3°
Maximum wind speed	12.5 m/s	<b>Drive speeds</b>	
Wheelbase	1.87 m	Stowed, maximum	3.5 km/h
Turning radius (outside)	2.10 m	Platform raised, maximum	0.8 km/h
Turning radius (inside)	0 m	<b>Floor loading information</b>	
Ground clearance	10 cm	Tire load, maximum	1000 kg
Ground clearance Pothole guards deployed	1.9 cm	Tire contact pressure	11.1 kg/cm <sup>2</sup> 1086.9 kPa
Weight (See Serial Label)		Occupied floor pressure	1339 kg/m <sup>2</sup> 13.1 kPa
Machine weights vary with option configurations		Note: Floor loading information is approximate and does not incorporate different option configurations. It should be used only with adequate safety factors.	
Controls	Proportional		
AC outlet in platform	Standard		

Continuous improvement of our products is a DINGLI policy. Product specifications are subject to change without notice or obligation.

**Specifications****Model: JCPT0812HA**

Height, working maximum	8 m	Maximum hydraulic pressure (functions)	240 bar
Height, platform maximum	6 m	System voltage	24 V
Height, stowed maximum Rails up	2.23 m	Tire size	Φ381×127 mm
Height, stowed maximum Rails folded	1.70 m	Airborne noise emissions	<70 dB
Width	1.15 m	Maximum sound level at normal operating workstations (A-weighted)	
Length, platform retracted	2.48 m	Vibration value does not exceed 2.5m/s <sup>2</sup>	
Length, platform extended	3.38 m	Maximum slope rating, Stowed position	25%
Platform dimensions (length × width)	2.27×1.12 m	Maximum side slope rating, Stowed position	25%
Platform extension length	0.9 m	Note: Slope rating is subject to ground conditions and adequate traction.	
Maximum load capacity	540 kg	Maximum working slope	X-1.5°, Y-3°
Maximum wind speed	12.5 m/s	<b>Drive speeds</b>	
Wheelbase	1.87 m	Stowed, maximum	3.5 km/h
Turning radius (outside)	2.2 m	Platform raised, maximum	0.8 km/h
Turning radius (inside)	0 m	<b>Floor loading information</b>	
Ground clearance	10 cm	Tire load, maximum	1000kg
Ground clearance Pothole guards deployed	1.9 cm	Tire contact pressure	9.9 kg/cm <sup>2</sup> 972.3 kPa
Weight (See Serial Label)		Occupied floor pressure	883.6 kg/m <sup>2</sup> 8.6 kPa
Machine weights vary with option configurations		Note: Floor loading information is approximate and does not incorporate different option configurations. It should be used only with adequate safety factors.	
Controls	Proportional		
AC outlet in platform	Standard		

Continuous improvement of our products is a DINGLI policy. Product specifications are subject to change without notice or obligation.

## Specifications

### Model: JCPT1008HA

Height, working maximum	10 m	Maximum hydraulic pressure (functions)	240 bar
Height, platform maximum	8 m	System voltage	24 V
Height, stowed maximum Rails up	2.36 m	Tire size	Φ381×127 mm
Height, stowed maximum Rails folded	2.00 m	Airborne noise emissions	<70 dB
Width	0.83 m	Maximum sound level at normal operating workstations (A-weighted)	
Length, platform retracted	2.48 m	Vibration value does not exceed 2.5m/s <sup>2</sup>	
Length, platform extended	3.38 m	Maximum slope rating, Stowed position	25%
Platform dimensions (length × width)	2.27×0.81 m	Maximum side slope rating, Stowed position	25%
Platform extension length	0.9 m	Note: Slope rating is subject to ground conditions and adequate traction.	
Maximum load capacity	230 kg	Maximum working slope	X-1.5°, Y-3°
Maximum wind speed	0 m/s	<b>Drive speeds</b>	
Wheelbase	1.87 m	Stowed, maximum	3.5 km/h
Turning radius (outside)	2.1 m	Platform raised, maximum	0.8 km/h
Turning radius (inside)	0 m	<b>Floor loading information</b>	
Ground clearance	10 cm	Tire load, maximum	960 kg
Ground clearance Pothole guards deployed	1.9 cm	Tire contact pressure	10.7 kg/cm <sup>2</sup> 1045 kPa
Weight (See Serial Label)		Occupied floor pressure	1287.4 kg/m <sup>2</sup> 12.6 kPa
Machine weights vary with option configurations		Note: Floor loading information is approximate and does not incorporate different option configurations. It should be used only with adequate safety factors.	
Controls	Proportional		
AC outlet in platform	Standard		

Continuous improvement of our products is a DINGLI policy. Product specifications are subject to change without notice or obligation.

**Specifications****Model: JCPT1012HA**

Height, working maximum	10 m	Maximum hydraulic pressure (functions)	240 bar
Height, platform maximum	8 m	System voltage	24 V
Height, stowed maximum Rails up	2.36 m	Tire size	Φ381×127 mm
Height, stowed maximum Rails folded	1.83 m	Airborne noise emissions	<70 dB
Width	1.15 m	Maximum sound level at normal operating workstations (A-weighted)	
Length, platform retracted	2.48 m	Vibration value does not exceed 2.5m/s <sup>2</sup>	
Length, platform extended	3.38 m	Maximum slope rating, Stowed position	25%
Platform dimensions (length × width)	2.27×1.12 m	Maximum side slope rating, Stowed position	25%
Platform extension length	0.9 m	Note: Slope rating is subject to ground conditions and adequate traction.	
Maximum load capacity	450 kg	Maximum working slope	X-1.5°, Y-3°
Maximum wind speed	12.5 m/s	<b>Drive speeds</b>	
Wheelbase	1.87 m	Stowed, maximum	3.5 km/h
Turning radius (outside)	2.2 m	Platform raised, maximum	0.8 km/h
Turning radius (inside)	0 m	<b>Floor loading information</b>	
Ground clearance	10 cm	Tire load, maximum	1240 kg
Ground clearance Pothole guards deployed	1.9 cm	Tire contact pressure	12.1 kg/cm <sup>2</sup> 1182.6 kPa
Weight (See Serial Label)		Occupied floor pressure	1174.1 kg/m <sup>2</sup> 11.5 kPa
Machine weights vary with option configurations		Note: Floor loading information is approximate and does not incorporate different option configurations. It should be used only with adequate safety factors.	
Controls	Proportional		
AC outlet in platform	Standard		

Continuous improvement of our products is a DINGLI policy. Product specifications are subject to change without notice or obligation.

## Specifications

### Model: JCPT1212HA

Height, working maximum	12 m	Maximum hydraulic pressure (functions)	240 bar
Height, platform maximum	10 m	System voltage	24 V
Height, stowed maximum Rails up	2.49 m	Tire size	Φ381×127 mm
Height, stowed maximum Rails folded	1.96 m	Airborne noise emissions	<70 dB
Width	1.15 m	Maximum sound level at normal operating workstations (A-weighted)	
Length, platform retracted	2.48 m	Vibration value does not exceed 2.5m/s <sup>2</sup>	
Length, platform extended	3.38 m	Maximum slope rating, Stowed position	25%
Platform dimensions (length × width)	2.27×1.12 m	Maximum side slope rating, Stowed position	25%
Platform extension length	0.9 m	Note: Slope rating is subject to ground conditions and adequate traction.	
Maximum load capacity	320 kg	Maximum working slope	X-1.5°, Y-3°
Maximum wind speed	12.5 m/s	<b>Drive speeds</b>	
Wheelbase	1.87 m	Stowed, maximum	3.5 km/h
Turning radius (outside)	2.2 m	Platform raised, maximum	0.8 km/h
Turning radius (inside)	0 m	<b>Floor loading information</b>	
Ground clearance	10 cm	Tire load, maximum	1310 kg
Ground clearance Pothole guards deployed	1.9 cm	Tire contact pressure	12.9 kg/cm <sup>2</sup> 1259.7 kPa
Weight (See Serial Label)		Occupied floor pressure	1250.7 kg/m <sup>2</sup> 12.3 kPa
Machine weights vary with option configurations		Note: Floor loading information is approximate and does not incorporate different option configurations. It should be used only with adequate safety factors.	
Controls	Proportional		
AC outlet in platform	Standard		

Continuous improvement of our products is a DINGLI policy. Product specifications are subject to change without notice or obligation.

**Specifications****Model: JCPT1412HA**

Height, working maximum	13.8 m	Maximum hydraulic pressure (functions)	240 bar
Height, platform maximum	11.8 m	System voltage	24 V
Height, stowed maximum Rails up	2.62 m	Tire size	Φ381×127 mm
Height, stowed maximum Rails folded	2.09 m	Airborne noise emissions	<70 dB
Width	1.19 m	Maximum sound level at normal operating workstations (A-weighted)	
Length, platform retracted	2.48 m	Vibration value does not exceed 2.5m/s <sup>2</sup>	
Length, platform extended	3.38 m	Maximum slope rating, Stowed position	25%
Platform dimensions (length × width)	2.27×1.12 m	Maximum side slope rating, Stowed position	25%
Platform extension length	0.9 m	Note: Slope rating is subject to ground conditions and adequate traction.	
Maximum load capacity	320 kg	Maximum working slope	X-1.5°, Y-3°
Maximum wind speed	0 m/s	<b>Drive speeds</b>	
Wheelbase	1.87 m	Stowed, maximum	3.5 km/h
Turning radius (outside)	2.2 m	Platform raised, maximum	0.8 km/h
Turning radius (inside)	0 m	<b>Floor loading information</b>	
Ground clearance	10 cm	Tire load, maximum	1280 kg
Ground clearance Pothole guards deployed	1.9 cm	Tire contact pressure	11.1 kg/cm <sup>2</sup> 1083.7 kPa
Weight (See Serial Label)		Occupied floor pressure	1169.8 kg/m <sup>2</sup> 11.5 kPa
Machine weights vary with option configurations		Note: Floor loading information is approximate and does not incorporate different option configurations. It should be used only with adequate safety factors.	
Controls	Proportional		
AC outlet in platform	Standard		

Continuous improvement of our products is a DINGLI policy. Product specifications are subject to change without notice or obligation.



## Specifications

### Model: JCPT1612HA

Height, working maximum	15.7 m	Maximum hydraulic pressure (functions)	240 bar
Height, platform maximum	13.7 m	System voltage	24 V
Height, stowed maximum Rails up	2.62 m	Tire size	Φ381×127 mm
Height, stowed maximum Rails folded	2.09 m	Airborne noise emissions	<70 dB
Width	1.25 m	Maximum sound level at normal operating workstations (A-weighted)	
Length, platform retracted	2.84 m	Vibration value does not exceed 2.5m/s <sup>2</sup>	
Length, platform extended	3.74 m	Maximum slope rating, Stowed position	25%
Platform dimensions (length × width)	2.64×1.12 m	Maximum side slope rating, Stowed position	25%
Platform extension length	0.9 m	Note: Slope rating is subject to ground conditions and adequate traction.	
Maximum load capacity	250 kg	Maximum working slope	X-1.5°, Y-3°
Maximum wind speed	0 m/s	<b>Drive speeds</b>	
Wheelbase	2.22 m	Stowed, maximum	3.5 km/h
Turning radius (outside)	2.65 m	Platform raised, maximum	0.8 km/h
Turning radius (inside)	0 m	<b>Floor loading information</b>	
Ground clearance	10 cm	Tire load, maximum	1350 kg
Ground clearance Pothole guards deployed	1.9 cm	Tire contact pressure	11.7 kg/cm <sup>2</sup> 1142 kPa
Weight (See Serial Label)		Occupied floor pressure	1013.1 kg/m <sup>2</sup> 9.9 kPa
Machine weights vary with option configurations		Note: Floor loading information is approximate and does not incorporate different option configurations. It should be used only with adequate safety factors.	
Controls	Proportional		
AC outlet in platform	Standard		

Continuous improvement of our products is a DINGLI policy. Product specifications are subject to change without notice or obligation.

**Specifications****Model: JCPT1612HAS**

Height, working maximum	15.7 m	Maximum hydraulic pressure (functions)	240 bar
Height, platform maximum	13.7 m	System voltage	24 V
Height, stowed maximum Rails up	2.75 m	Tire size	Φ381×127 mm
Height, stowed maximum Rails folded	2.22 m	Airborne noise emissions	<70 dB
Width	1.19 m	Maximum sound level at normal operating workstations (A-weighted)	
Length, platform retracted	2.48 m	Vibration value does not exceed 2.5m/s <sup>2</sup>	
Length, platform extended	3.38 m	Maximum slope rating, Stowed position	25%
Platform dimensions (length × width)	2.27×1.12 m	Maximum side slope rating, Stowed position	25%
Platform extension length	0.9 m	Note: Slope rating is subject to ground conditions and adequate traction.	
Maximum load capacity	250 kg	Maximum working slope	X-1.5°,Y-3°
Maximum wind speed	0 m/s	<b>Drive speeds</b>	
Wheelbase	1.87 m	Stowed, maximum	3.5 km/h
Turning radius (outside)	2.20 m	Platform raised, maximum	0.8 km/h
Turning radius (inside)	0 m	<b>Floor loading information</b>	
Ground clearance	10 cm	Tire load, maximum	1350 kg
Ground clearance Pothole guards deployed	1.9 cm	Tire contact pressure	11.7 kg/cm <sup>2</sup> 1142 kPa
Weight (See Serial Label)		Occupied floor pressure	1013.1 kg/m <sup>2</sup> 9.9 kPa
Machine weights vary with option configurations		Note: Floor loading information is approximate and does not incorporate different option configurations. It should be used only with adequate safety factors.	
Controls	Proportional		
AC outlet in platform	Standard		

Continuous improvement of our products is a DINGLI policy. Product specifications are subject to change without notice or obligation.

## Specifications

### Model: JCPT0807AC

Height, working maximum	7.8 m	Maximum hydraulic pressure (functions)	180bar
Height, platform maximum	5.8 m	System voltage	24 V
Height, stowed maximum Rails up	2.15 m	Tire size	Φ323×100 mm
Height, stowed maximum Rails folded	1.83 m	Airborne noise emissions	<70 dB
Width	0.76 m	Maximum sound level at normal operating workstations (A-weighted)	
Length, platform retracted	1.86 m	Vibration value does not exceed 2.5m/s <sup>2</sup>	
Length, platform extended	2.76 m	Maximum slope rating, Stowed position	25%
Platform dimensions (length × width)	1.67×0.74 m	Maximum side slope rating, Stowed position	25%
Platform extension length	0.9 m	Note: Slope rating is subject to ground conditions and adequate traction.	
Maximum load capacity	230 kg	Maximum working slope	X-1.5°, Y-3°
Maximum wind speed	12.5 m/s	<b>Drive speeds</b>	
Wheelbase	1.36 m	Stowed, maximum	4.5 km/h
Turning radius (outside)	1.64 m	Platform raised, maximum	0.6 km/h
Turning radius (inside)	0 m	<b>Floor loading information</b>	
Ground clearance	9 cm	Tire load, maximum	710kg
Ground clearance Pothole guards deployed	1.6 cm	Tire contact pressure	10.4kg/cm <sup>2</sup> 1019kPa
Weight (See Serial Label)		Occupied floor pressure	1373kg/m <sup>2</sup> 13.5kPa
Machine weights vary with option configurations		Note: Floor loading information is approximate and does not incorporate different option configurations. It should be used only with adequate safety factors.	
Controls	Proportional		
AC outlet in platform	Standard		

Continuous improvement of our products is a DINGLI policy. Product specifications are subject to change without notice or obligation.

**Specifications****Model: JCPT0808AC**

Height, working maximum	8 m	Maximum hydraulic pressure (functions)	240 bar
Height, platform maximum	6 m	System voltage	24 V
Height, stowed maximum Rails up	2.23 m	Tire size	Φ381×127 mm
Height, stowed maximum Rails folded	1.87 m	Airborne noise emissions	<70 dB
Width	0.83 m	Maximum sound level at normal operating workstations (A-weighted)	
Length, platform retracted	2.48 m	Vibration value does not exceed 2.5m/s <sup>2</sup>	
Length, platform extended	3.38 m	Maximum slope rating, Stowed position	25%
Platform dimensions (length × width)	2.27×0.81 m	Maximum side slope rating, Stowed position	25%
Platform extension length	0.9 m	Note: Slope rating is subject to ground conditions and adequate traction.	
Maximum load capacity	380 kg	Maximum working slope	X-1.5°, Y-3°
Maximum wind speed	12.5 m/s	<b>Drive speeds</b>	
Wheelbase	1.87 m	Stowed, maximum	5.0 km/h
Turning radius (outside)	2.1 m	Platform raised, maximum	0.8 km/h
Turning radius (inside)	0 m	<b>Floor loading information</b>	
Ground clearance	10 cm	Tire load, maximum	1000 kg
Ground clearance Pothole guards deployed	1.9 cm	Tire contact pressure	11.3 kg/cm <sup>2</sup> 1104.6 kPa
Weight (See Serial Label)		Occupied floor pressure	1360.7 kg/m <sup>2</sup> 13.3 kPa
Machine weights vary with option configurations		Note: Floor loading information is approximate and does not incorporate different option configurations. It should be used only with adequate safety factors.	
Controls	Proportional		
AC outlet in platform	Standard		

Continuous improvement of our products is a DINGLI policy. Product specifications are subject to change without notice or obligation.

## Specifications

### Model: JCPT0812AC

Height, working maximum	8 m	Maximum hydraulic pressure (functions)	240 bar
Height, platform maximum	6 m	System voltage	24 V
Height, stowed maximum Rails up	2.23 m	Tire size	Φ381×127 mm
Height, stowed maximum Rails folded	1.70 m	Airborne noise emissions	<70 dB
Width	1.15 m	Maximum sound level at normal operating workstations (A-weighted)	
Length, platform retracted	2.48 m	Vibration value does not exceed 2.5m/s <sup>2</sup>	
Length, platform extended	3.38 m	Maximum slope rating, Stowed position	25%
Platform dimensions (length × width)	2.27×1.12 m	Maximum side slope rating, Stowed position	25%
Platform extension length	0.9 m	Note: Slope rating is subject to ground conditions and adequate traction.	
Maximum load capacity	540 kg	Maximum working slope	X-1.5°, Y-3°
Maximum wind speed	12.5 m/s	<b>Drive speeds</b>	
Wheelbase	1.87 m	Stowed, maximum	5.0 km/h
Turning radius (outside)	2.2 m	Platform raised, maximum	0.8 km/h
Turning radius (inside)	0 m	<b>Floor loading information</b>	
Ground clearance	10 cm	Tire load, maximum	1000kg
Ground clearance Pothole guards deployed	1.9 cm	Tire contact pressure	9.9 kg/cm <sup>2</sup> 972.3 kPa
Weight (See Serial Label)		Occupied floor pressure	883.6 kg/m <sup>2</sup> 8.6 kPa
Machine weights vary with option configurations		Note: Floor loading information is approximate and does not incorporate different option configurations. It should be used only with adequate safety factors.	
Controls	Proportional		
AC outlet in platform	Standard		

Continuous improvement of our products is a DINGLI policy. Product specifications are subject to change without notice or obligation.

**Specifications****Model: JCPT1008AC**

Height, working maximum	10 m	Maximum hydraulic pressure (functions)	240 bar
Height, platform maximum	8 m	System voltage	24 V
Height, stowed maximum Rails up	2.36 m	Tire size	Φ381×127 mm
Height, stowed maximum Rails folded	2.00 m	Airborne noise emissions	<70 dB
Width	0.83 m	Maximum sound level at normal operating workstations (A-weighted)	
Length, platform retracted	2.48 m	Vibration value does not exceed 2.5m/s <sup>2</sup>	
Length, platform extended	3.38 m	Maximum slope rating, Stowed position	25%
Platform dimensions (length × width)	2.27×0.81 m	Maximum side slope rating, Stowed position	25%
Platform extension length	0.9 m	Note: Slope rating is subject to ground conditions and adequate traction.	
Maximum load capacity	230 kg	Maximum working slope	X-1.5°, Y-3°
Maximum wind speed	0 m/s	<b>Drive speeds</b>	
Wheelbase	1.87 m	Stowed, maximum	5.0 km/h
Turning radius (outside)	2.1 m	Platform raised, maximum	0.8 km/h
Turning radius (inside)	0 m	<b>Floor loading information</b>	
Ground clearance	10 cm	Tire load, maximum	960 kg
Ground clearance Pothole guards deployed	1.9 cm	Tire contact pressure	10.8 kg/cm <sup>2</sup> 1062.7 kPa
Weight (See Serial Label)		Occupied floor pressure	1309.1 kg/m <sup>2</sup> 12.8 kPa
Machine weights vary with option configurations		Note: Floor loading information is approximate and does not incorporate different option configurations. It should be used only with adequate safety factors.	
Controls	Proportional		
AC outlet in platform	Standard		

Continuous improvement of our products is a DINGLI policy. Product specifications are subject to change without notice or obligation.

## Specifications

### Model: JCPT1012AC

Height, working maximum	10 m	Maximum hydraulic pressure (functions)	240 bar
Height, platform maximum	8 m	System voltage	24 V
Height, stowed maximum Rails up	2.36 m	Tire size	Φ381×127 mm
Height, stowed maximum Rails folded	1.83 m	Airborne noise emissions	<70 dB
Width	1.15 m	Maximum sound level at normal operating workstations (A-weighted)	
Length, platform retracted	2.48 m	Vibration value does not exceed 2.5m/s <sup>2</sup>	
Length, platform extended	3.38 m	Maximum slope rating, Stowed position	25%
Platform dimensions (length × width)	2.27×1.12 m	Maximum side slope rating, Stowed position	25%
Platform extension length	0.9 m	Note: Slope rating is subject to ground conditions and adequate traction.	
Maximum load capacity	450 kg	Maximum working slope	X-1.5°, Y-3°
Maximum wind speed	12.5 m/s	<b>Drive speeds</b>	
Wheelbase	1.87 m	Stowed, maximum	5.0 km/h
Turning radius (outside)	2.2 m	Platform raised, maximum	0.8 km/h
Turning radius (inside)	0 m	<b>Floor loading information</b>	
Ground clearance	10 cm	Tire load, maximum	1240 kg
Ground clearance Pothole guards deployed	1.9 cm	Tire contact pressure	12.2 kg/cm <sup>2</sup> 1198 kPa
Weight (See Serial Label)		Occupied floor pressure	1189.4 kg/m <sup>2</sup> 11.7 kPa
Machine weights vary with option configurations		Note: Floor loading information is approximate and does not incorporate different option configurations. It should be used only with adequate safety factors.	
Controls	Proportional		
AC outlet in platform	Standard		

Continuous improvement of our products is a DINGLI policy. Product specifications are subject to change without notice or obligation.

**Specifications****Model: JCPT1212AC**

Height, working maximum	12 m	Maximum hydraulic pressure (functions)	240 bar
Height, platform maximum	10 m	System voltage	24 V
Height, stowed maximum Rails up	2.49 m	Tire size	Φ381×127 mm
Height, stowed maximum Rails folded	1.96 m	Airborne noise emissions	<70 dB
Width	1.15 m	Maximum sound level at normal operating workstations (A-weighted)	
Length, platform retracted	2.48 m	Vibration value does not exceed 2.5m/s <sup>2</sup>	
Length, platform extended	3.38 m	Maximum slope rating, Stowed position	25%
Platform dimensions (length × width)	2.27×1.12 m	Maximum side slope rating, Stowed position	25%
Platform extension length	0.9 m	Note: Slope rating is subject to ground conditions and adequate traction.	
Maximum load capacity	320 kg	Maximum working slope	X-1.5°, Y-3°
Maximum wind speed	12.5 m/s	<b>Drive speeds</b>	
Wheelbase	1.87 m	Stowed, maximum	5.0 km/h
Turning radius (outside)	2.2 m	Platform raised, maximum	0.8 km/h
Turning radius (inside)	0 m	<b>Floor loading information</b>	
Ground clearance	10 cm	Tire load, maximum	1310 kg
Ground clearance Pothole guards deployed	1.9 cm	Tire contact pressure	12.9 kg/cm <sup>2</sup> 1267.4 kPa
Weight (See Serial Label)		Occupied floor pressure	1258.4 kg/m <sup>2</sup> 12.3 kPa
Machine weights vary with option configurations		Note: Floor loading information is approximate and does not incorporate different option configurations. It should be used only with adequate safety factors.	
Controls	Proportional		
AC outlet in platform	Standard		

Continuous improvement of our products is a DINGLI policy. Product specifications are subject to change without notice or obligation.



## Specifications

### Model: JCPT1412AC

Height, working maximum	13.8 m	Maximum hydraulic pressure (functions)	240 bar
Height, platform maximum	11.8 m	System voltage	24 V
Height, stowed maximum Rails up	2.62 m	Tire size	Φ381×127 mm
Height, stowed maximum Rails folded	2.09 m	Airborne noise emissions	<70 dB
Width	1.19 m	Maximum sound level at normal operating workstations (A-weighted)	
Length, platform retracted	2.48 m	Vibration value does not exceed 2.5m/s <sup>2</sup>	
Length, platform extended	3.38 m	Maximum slope rating, Stowed position	25%
Platform dimensions (length × width)	2.27×1.12 m	Maximum side slope rating, Stowed position	25%
Platform extension length	0.9 m	Note: Slope rating is subject to ground conditions and adequate traction.	
Maximum load capacity	320 kg	Maximum working slope	X-1.5°, Y-3°
Maximum wind speed	0 m/s	<b>Drive speeds</b>	
Wheelbase	1.87 m	Stowed, maximum	5.0 km/h
Turning radius (outside)	2.2 m	Platform raised, maximum	0.8 km/h
Turning radius (inside)	0 m	<b>Floor loading information</b>	
Ground clearance	10 cm	Tire load, maximum	1280 kg
Ground clearance Pothole guards deployed	1.9 cm	Tire contact pressure	11.2 kg/cm <sup>2</sup> 1097.5 kPa
Weight (See Serial Label)		Occupied floor pressure	1184.6 kg/m <sup>2</sup> 11.6 kPa
Machine weights vary with option configurations		Note: Floor loading information is approximate and does not incorporate different option configurations. It should be used only with adequate safety factors.	
Controls	Proportional		
AC outlet in platform	Standard		

Continuous improvement of our products is a DINGLI policy. Product specifications are subject to change without notice or obligation.

**Specifications****Model: JCPT1612AC**

Height, working maximum	15.7 m	Maximum hydraulic pressure (functions)	240 bar
Height, platform maximum	13.7 m	System voltage	24 V
Height, stowed maximum Rails up	2.62 m	Tire size	Φ381×127 mm
Height, stowed maximum Rails folded	2.09 m	Airborne noise emissions	<70 dB
Width	1.25 m	Maximum sound level at normal operating workstations (A-weighted)	
Length, platform retracted	2.84 m	Vibration value does not exceed 2.5m/s <sup>2</sup>	
Length, platform extended	3.74 m	Maximum slope rating, Stowed position	25%
Platform dimensions (length × width)	2.64×1.12 m	Maximum side slope rating, Stowed position	25%
Platform extension length	0.9 m	Note: Slope rating is subject to ground conditions and adequate traction.	
Maximum load capacity	250 kg	Maximum working slope	X-1.5°, Y-3°
Maximum wind speed	0 m/s	<b>Drive speeds</b>	
Wheelbase	2.22 m	Stowed, maximum	5.0 km/h
Turning radius (outside)	2.65 m	Platform raised, maximum	0.8 km/h
Turning radius (inside)	0 m	<b>Floor loading information</b>	
Ground clearance	10 cm	Tire load, maximum	1350 kg
Ground clearance Pothole guards deployed	1.9 cm	Tire contact pressure	11.8 kg/cm <sup>2</sup> 1159.2 kPa
Weight (See Serial Label)		Occupied floor pressure	1028.4 kg/m <sup>2</sup> 10.1 kPa
Machine weights vary with option configurations		Note: Floor loading information is approximate and does not incorporate different option configurations. It should be used only with adequate safety factors.	
Controls	Proportional		
AC outlet in platform	Standard		

Continuous improvement of our products is a DINGLI policy. Product specifications are subject to change without notice or obligation.

## Specifications

### Model: JCPT1612ACS

Height, working maximum	15.7 m	Maximum hydraulic pressure (functions)	240 bar
Height, platform maximum	13.7 m	System voltage	24 V
Height, stowed maximum Rails up	2.75 m	Tire size	Φ381×127 mm
Height, stowed maximum Rails folded	2.22 m	Airborne noise emissions	<70 dB
Width	1.19 m	Maximum sound level at normal operating workstations (A-weighted)	
Length, platform retracted	2.48 m	Vibration value does not exceed 2.5m/s <sup>2</sup>	
Length, platform extended	3.38 m	Maximum slope rating, Stowed position	25%
Platform dimensions (length × width)	2.27×1.12 m	Maximum side slope rating, Stowed position	25%
Platform extension length	0.9 m	Note: Slope rating is subject to ground conditions and adequate traction.	
Maximum load capacity	250 kg	Maximum working slope	X-1.5°, Y-3°
Maximum wind speed	0 m/s	<b>Drive speeds</b>	
Wheelbase	1.87 m	Stowed, maximum	5.0 km/h
Turning radius (outside)	2.20 m	Platform raised, maximum	0.8 km/h
Turning radius (inside)	0 m	<b>Floor loading information</b>	
Ground clearance	10 cm	Tire load, maximum	1350 kg
Ground clearance Pothole guards deployed	1.9 cm	Tire contact pressure	11.7 kg/cm <sup>2</sup> 1142 kPa
Weight	(See Serial Label)	Occupied floor pressure	1013.1 kg/m <sup>2</sup> 9.9 kPa
Machine weights vary with option configurations		Note: Floor loading information is approximate and does not incorporate different option configurations. It should be used only with adequate safety factors.	
Controls	Proportional	Continuous improvement of our products is a DINGLI policy. Product specifications are subject to change without notice or obligation.	
AC outlet in platform	Standard		

**Specifications****Battery Specifications****Lead-acid battery**

JCPT0807AC, JCPT0807HA, JCPT0808AC, JCPT0808HA, JCPT0812AC, JCPT0812HA, JCPT1008AC, JCPT1008HA, JCPT1012AC, JCPT1012HA	standard	JCPT1212AC, JCPT1212HA	optional
Voltage	6VDC	Voltage	6VDC
Type	6TB170	Type	T-125 Plus
Quantity	4	Quantity	4
Battery capacity, maximum	170Ah	Battery capacity, maximum	240Ah
Maintenance-free	Yes	Maintenance-free	No
JCPT0807AC, JCPT0807HA	optional	JCPT1412AC, JCPT1412HA, JCPT1612AC, JCPT1612HA, JCPT1612ACS, JCPT1612HAS,	standard
Voltage	12VDC	Voltage	12VDC
Type	T-605	Type	12TB120
Quantity	4	Quantity	4
Battery capacity, maximum	210Ah	Battery capacity, maximum	240Ah
Maintenance-free	No	Maintenance-free	Yes
JCPT0808AC, JCPT0808HA, JCPT0812AC, JCPT0812HA, JCPT1008AC, JCPT1008HA, JCPT1012AC, JCPT1012HA	optional	JCPT1412AC, JCPT1412HA, JCPT1612AC, JCPT1612HA, JCPT1612ACS, JCPT1612HAS,	optional
Voltage	6VDC	Voltage	6VDC
Type	T-105 Plus	Type	6TB220
Quantity	4	Quantity	4
Battery capacity, maximum	225Ah	Battery capacity, maximum	220Ah
Maintenance-free	No	Maintenance-free	Yes
JCPT1212AC, JCPT1212HA	standard	JCPT1412AC, JCPT1412HA, JCPT1612AC, JCPT1612HA, JCPT1612ACS, JCPT1612HAS,	optional
Voltage	6VDC	Voltage	12VDC
Type	6TB220	Type	T-1275 Plus
Quantity	4	Quantity	4
Battery capacity, maximum	220Ah	Battery capacity, maximum	150Ah
Maintenance-free	Yes	Maintenance-free	No

## Specifications

### Lithium battery

JCPT0807AC, JCPT0807HA, JCPT0808AC, JCPT0808HA, JCPT0812AC, JCPT0812HA, JCPT1008AC, JCPT1008HA, JCPT1012AC, JCPT1012HA	optional
Voltage	24VDC
Type	TFL24-180-DL3
Quantity	1
Battery capacity, maximum	180AH
Maintenance-free	Yes
JCPT1212AC, JCPT1212HA, JCPT1412AC, JCPT1412HA, JCPT1612AC, JCPT1612HA, JCPT1612ACS, JCPT1612HAS	optional
Voltage	24VDC
Type	TFL24-220-DL2
Quantity	1
Battery capacity, maximum	220AH
Maintenance-free	Yes

## Control Panel

### Ground Control Panel

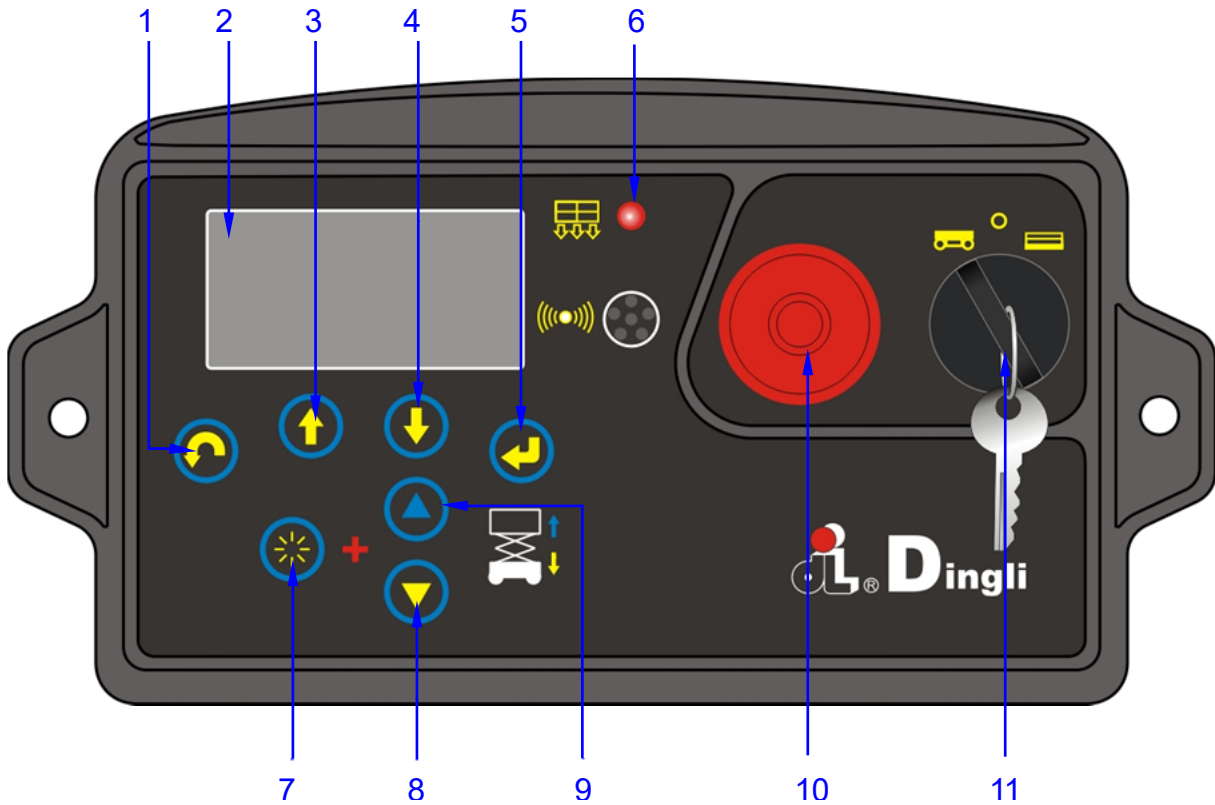

1 Menu escape button

2 LED readout screen

3 Menu up button

4 Menu down button

5 Menu enter button

6 Overload indicator light

7 Function enable button

8.. Platform down button

9 Platform up button

10 Red Emergency Stop button

Push in the red Emergency Stop button to the off position to stop all functions. Pull out the red Emergency Stop button to the on position to operate the machine.

11 Key switch

Turn the key switch to the platform position and the platform controls will operate. Turn the key switch to the off position and the machine will be off. Turn the key switch to the base position and the ground controls will operate.

## Control Panel

### Platform Control Panel

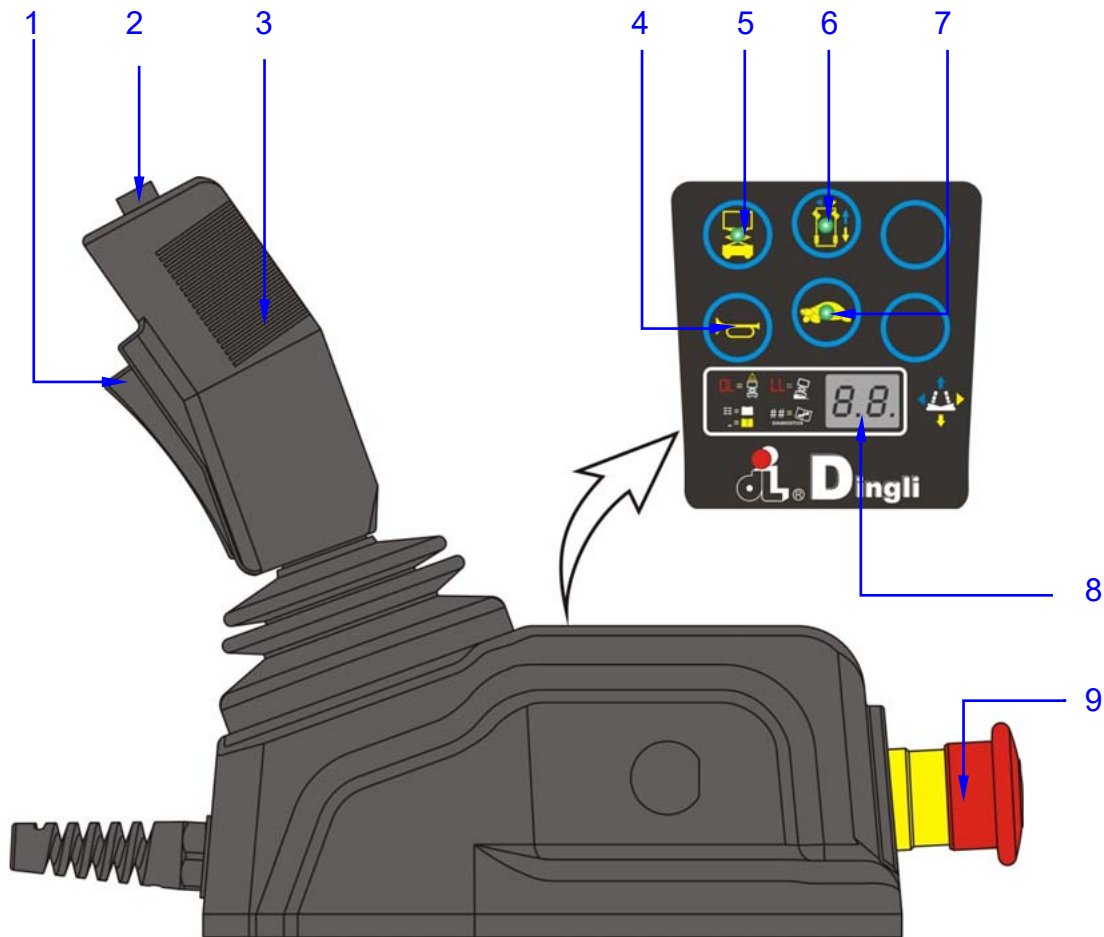

- |   |                             |   |                              |
|---|-----------------------------|---|------------------------------|
| 1 | Function enable switch      | 6 | Drive function select button |
| 2 | Thumb rocker switch         | 7 | Drive speed button           |
| 3 | Proportional control handle | 8 | LED readout screen           |
| 4 | Horn button                 | 9 | Red Emergency Stop button    |
| 5 | Lift function select button |   |                              |

## Control Panel

### Platform Control Panel

1 Function enable switch

Press and hold the function enable switch to enable the drive/lift function.

2 Thumb rocker switch

Press the thumb rocker switch in either direction to activate steer function.

3 Proportional control handle

Lift function: Press and hold the function enable switch to enable the lift function on the platform control handle. Move the control handle in the direction indicated by the blue arrow and the platform will raise. Move the control handle in the direction indicated by the yellow arrow and the platform will lower. The descent alarm should sound while the platform is lowering.

Drive function: Press and hold the function enable switch to enable the drive function on the platform control handle. Move the control handle in the direction indicated by the blue arrow on the control panel and the machine will move in the direction that the blue arrow points. Move the control handle in the direction indicated by the yellow arrow on the control panel and the machine will move in the direction that the yellow arrow points.

4 Horn Button

Push the horn button and the horn will sound. Release the horn button and the horn will stop.

5 Lift function select button

Press this button to activate the lift function.

6 Drive function select button

Press this button to activate the drive function.

7 Drive speed button

Press this button to activate the slow or fast drive function.

8 LED readout screen

Diagnostic readout and battery charge indicator.

9 Red Emergency Stop button

Push in the red Emergency Stop button to the off position to stop all functions. Pull out the red Emergency Stop button to the on position to operate the machine.



## Pre-operation Inspection



### Do Not Operate Unless:

You learn and practice the principles of safe machine operation contained in this operator's manual.

- 1 Avoid hazardous situations.
- 2 Always perform a pre-operation inspection.**

**Know and understand the pre-operation inspection before going on to the next section.**

- 3 Inspect the workplace.
- 4 Always perform function tests prior to use.
- 5 Only use the machine as it was intended.

### Fundamentals

It is the responsibility of the operator to perform a pre-operation inspection and routine maintenance.

The pre-operation inspection is a visual inspection performed by the operator prior to each work shift. The inspection is designed to discover if anything is apparently wrong with a machine before the operator performs the function tests.

The pre-operation inspection also serves to determine if routine maintenance procedures are required. Only routine maintenance items specified in this manual may be performed by the operator.

Refer to the list on the next page and check each of the items.

If damage or any unauthorized variation from factory delivered condition is discovered, the machine must be tagged and removed from service.

Repairs to the machine may only be made by a qualified service technician, according to the manufacturer's specifications. After repairs are completed, the operator must perform a pre-operation inspection again before going on to the function tests.

Scheduled maintenance inspections shall be performed by qualified service technicians, according to the manufacturer's specifications and the requirements listed in this manual.

## Pre-operation Inspection

### Pre-operation Inspection

- Be sure that the operator's manual are complete, legible and in the storage container located in the platform.
- Be sure that all decals are legible and in place. See Decals section.
- Check for hydraulic oil leaks and proper oil level. Add oil if needed. See Maintenance section.
- Check for battery fluid leaks and proper fluid level. Add distilled water if needed. See Maintenance section.

Check the following components or areas for damage, improperly installed or missing parts and unauthorized modifications:

- Electrical components, wiring and electrical cables
- Hydraulic hoses, fittings, cylinders and manifolds
- Battery pack and connections
- Drive motors
- Wear pads
- Tires and wheels
- Ground strap
- Limit switches, alarms and horn
- Nuts, bolts and other fasteners
- Platform overload components
- Platform entry gate
- Beacon (if equipped)
- Safety arm
- Platform extension(s)
- Scissor pins and retaining fasteners
- Platform control joystick
- Brake release components
- Pothole guard

Check entire machine for:

- Cracks in welds or structural components
- Dents or damage to machine
- Be sure that all structural and other critical components are present and all associated fasteners and pins are in place and properly tightened
- Be sure side rails are installed and rail pins and bolts are fastened.
- Be sure that the chassis trays are closed and latched and the batteries are properly connected.

Note: If the platform must be raised to inspect the machine, make sure the safety arm is in place. See Operating Instructions section.

## Workplace Inspection



### Do Not Operate Unless:

You learn and practice the principles of safe machine operation contained in this operator's manual.

- 1 Avoid hazardous situations.
- 2 Always perform a pre-operation inspection.
- 3 Inspect the workplace.**

**Know and understand the workplace inspection before going on to the next section.**

- 4 Always perform function tests prior to use.
- 5 Only use the machine as it was intended.

### Fundamentals

The workplace inspection helps the operator determine if the workplace is suitable for safe machine operation. It should be performed by the operator prior to moving the machine to the workplace.

It is the operator's responsibility to read and remember the workplace hazards, then watch for and avoid them while moving, setting up and operating the machine.

### Workplace Inspection

Be aware of and avoid the following hazardous situations:

- Drop-offs or holes
- Bumps, floor obstructions or debris
- Sloped surfaces
- Unstable or slippery surfaces
- Overhead obstructions and high voltage conductors
- Hazardous locations
- Inadequate surface support to withstand all load forces imposed by the machine
- Wind and weather conditions
- The presence of unauthorized personnel
- Other possible unsafe conditions

## Function Tests



### Do Not Operate Unless:

You learn and practice the principles of safe machine operation contained in this operator's manual.

- 1 Avoid hazardous situations.
- 2 Always perform a pre-operation inspection.
- 3 Inspect the workplace.
- 4 **Always perform function tests prior to use.**

### Know and understand the function tests before going on to the next section.

- 5 Only use the machine as it was intended.

### Fundamentals

The function tests are designed to discover any malfunctions before the machine is put into service.

The operator must follow the step-by-step instructions to test all machine functions.

A malfunctioning machine must never be used. If malfunctions are discovered, the machine must be tagged and removed from service.

Repairs to the machine may only be made by a qualified service technician, according to the manufacturer's specifications.

After repairs are completed, the operator must perform a pre-operation inspection and function tests again before putting the machine into service.

## Function Tests

- 1 Select a test area that is firm, level and free of obstruction.
- 2 Be sure the battery pack is connected.
- 3 Pull out the main power switch to "on" position.

### At the Ground Controls

- 4 Pull out the platform and ground red Emergency Stop button to the on position.
- 5 Turn the key switch to ground control.
- 6 Observe the LED readout screen on the platform controls.

- ⊙ Result: The LED should look like the picture at right.



- 7 Observe the LED readout screen on the ECU window.
- ⊙ Result: The LED will come on and display system ready.

### Test Emergency Stop

- 8 Push in the ground red Emergency Stop button to the off position.
- ⊙ Result: No functions should operate.
- 9 Pull out the red Emergency Stop button to the on position.

### Test Up/Down Functions

A buzzer with different sound frequency is controlled in central system. The descent alarm sounds at 60 beeps per minute. The descent delay alarm sounds at 120 beeps per minute. The alarm that goes off when the pothole guards have not deployed sounds at 180 beeps per minute. The alarm that goes off when the machine is not level sounds at 180 beeps per minute. An optional automotive-style horn is also available.

- 10 Do not press the function enable button.

- 11 Press the platform up or platform down button.

- ⊙ Result: No function should operate.

- 12 Do not press the platform up or platform down buttons.

- 13 Press the function enable button.

- ⊙ Result: No function should operate.

- 14 Press and hold the function enable button, and press the platform up button.

- ⊙ Result: The platform should raise.

- 15 Press and hold the function enable button, and press the platform down button.

- ⊙ Result: The platform should lower. The descent alarm should sound while the platform is lowering. The platform stop at the height is approximately 2m from the ground. The descent delay alarm will sound.

Note: Be sure the area below the platform is clear of personnel and obstructions before continuing.

- 16 Press and hold the function enable button, and press the platform down button.

- ⊙ Result: The platform should lower to end. The descent delay alarm should sound while the platform is lowering.

### Test the Emergency Lowering

- 17 Activate the up function and raise the platform approximately 60 cm.

- 18 Pull the emergency lowering knob located on the ground controls side of the machine.

- ⊙ Result: The platform should lower. The descent alarm will not sound.

- 19 Turn the key switch to platform control.

## Function Tests

### At the Platform Controls

#### Test Emergency Stop

20 Push in the platform red Emergency Stop button to the off position.

⦿ Result: No functions should operate.

21 Pull out the red Emergency Stop button to the on position.

⦿ Result: The LED indicator light should come on.

#### Test the Horn

22 Push the horn button.

⦿ Result: The horn should sound.

#### Test Function Enable and Up/Down Functions

23 Do not hold the function enable switch on the control handle.

24 Slowly move the control handle in the direction indicated by the blue up arrow, then in the direction indicated by the yellow down arrow.

⦿ Result: No functions should operate.

25 Press the lift function select button.

26 Press and hold the function enable switch on the control handle.

27 Slowly move the control handle in the direction indicated by the blue up arrow.

⦿ Result: The platform should raise. The pothole guards should deploy.

28 Release the control handle.

⦿ Result: The platform should stop raising.

29 Press and hold the function enable switch. Slowly move the control handle in the direction indicated by the yellow down arrow.

⦿ Result: The platform should lower. The

descent alarm should sound while the platform is lowering.

#### Test the Steering

Note: When performing the steer and drive function tests, stand in the platform facing the steer end of the machine.

30 Press the drive function select button. The indicator light should turn on.

31 Press and hold the function enable switch on the control handle.

32 Depress the thumb rocker switch on top of the control handle in the direction identified by the blue left arrow on the control panel.

⦿ Result: The steer wheels should turn in the direction that the blue left arrow points on the control panel.

33 Depress the thumb rocker switch in the direction identified by the yellow right arrow on the control panel.

⦿ Result: The steer wheels should turn in the direction that the yellow right arrow points on the control panel.

#### Test Drive and Braking

34 Press the drive function select button. The indicator light should turn on.

35 Press and hold the function enable switch on the control handle.

36 Slowly move the control handle in the direction indicated by the blue up arrow on the control panel until the machine begins to move, then return the handle to the center position.

⦿ Result: The machine should move in the direction that the blue up arrow points on the control panel, then come to an abrupt stop.

37 Press and hold the function enable switch on the control handle.

## Function Tests

38 Slowly move the control handle in the direction indicated by the yellow down arrow on the control panel until the machine begins to move, then return the handle to the center position.

- ⊙ Result: The machine should move in the direction that the yellow down arrow points on the control panel, then come to an abrupt stop.

Note: The brakes must be able to hold the machine on any slope it is able to climb.

### Test Limited Drive Speed

39 Press and hold the function enable switch. Raise the platform approximately 2m from the ground.

- ⊙ Result: The pothole guards should deploy.

40 Press and hold the function enable switch on the control handle.

41 Slowly move the control handle to the full drive position.

- ⊙ Result: The maximum achievable drive speed with the platform raised should not exceed 22 cm/s.

- ⊘ Result: If the drive speed with the platform raised exceeds 22 cm/s, immediately tag and remove the machine from service.

### Test the Tilt Sensor Operation

Note: Perform this test from the ground with the platform controller. Do not stand in the platform.

42 Fully lower the platform.

43 Place a 3.5×20cm or similar piece of wood under both wheels on one side and drive the machine up onto them.

44 Raise the platform approximately 2m from the ground.

- ⊙ Result: The platform should stop and the tilt alarm will sound at 180 beeps per minute.

The platform controls LED readout should display LL.

45 Press the drive function select button.

46 Press and hold the function enable switch on the control handle.

47 Move the control handle in the direction indicated by the blue up arrow, then move the control handle in the direction indicated by the yellow down arrow.

- ⊙ Result: The drive function should not work in either direction.

48 Lower the platform and drive the machine off the block.

### Test the Pothole Guards

Note: The pothole guards should automatically deploy when the platform is raised. The pothole guards activate another limit switch which allows the machine to continue to function. If the pothole guards do not deploy, an alarm sounds and the machine will not drive and lift.

49 Raise the platform.

- ⊙ Result: When the platform is raised approximately 2m from the ground, the pothole guards should deploy.

50 Press on the pothole guards on one side, and then the other.

- ⊙ Result: The pothole guards should not move.

51 Lower the platform.

- ⊙ Result: The pothole guards should return to the stowed position.

52 Place a 3.5×20cm or similar piece of wood under a pothole guard. Raise the platform.

- ⊙ Result: When the platform is raised approximately 2m from the ground, the pothole alarm will sound at 180 beeps per minute, and the platform controls LED

## Function Tests

screen readout should display 18.

- 53 Press the drive function select button.
- 54 Press and hold the function enable switch on the control handle.
- 55 Move the control handle in the direction indicated by the blue up arrow, and then move the control handle in the direction indicated by the yellow down arrow.

⊙ Result: The drive function should not work in either direction.

- 56 Press and hold the function enable switch on the control handle.

- 57 Depress the thumb rocker switch on top of the control handle in the direction identified by the blue and yellow arrow on the control panel.

⊙ Result: The steer function should not work in either direction.

- 58 Lower the platform and remove the 3.5×20cm wood block.

### Testing Anti-collision protection Safety function (if equipped)

Note: The ultrasonic sensor system includes an ultrasonic sensor and its installation accessories, which are fixed on the platform controller bracket to detect obstacles directly above to prevent the machine or the operator from being injured.

This test needs to get the platform control to be ground connected (base plug) for testing, and the operator should not stand on the platform



Ultrasonic safety sensor



- 59 Drive the machine to a stop at 4 meters away from the obstacle.
  - 60 Rotate the platform controller, directly above of the ultrasonic sensor in line with the obstacle.
  - 61 Press the lifting function selection button, press and hold the function enable button on the joystick, and slowly approach the obstacle.
- ⊙ Result: When the platform control panel is 4m away from the obstacle, the alarm should beep 50 times per minute, and the platform LED display shows "0b".(obstacle)
- ⊗ Result: When the platform control is 4m away from the obstacle, the anti-collision warning alarm does not sound. Mark the machine immediately. And stop running.



## Function Tests

62 Try to raise the platform.

- ⊙ Result: The platform can be raised the alarm should beep 50 times per minute and continue, the platform LED display shows "Ob". (Obstacle)

63 Press the drive function enable button to drive the machine to a stop at 2 meters away from the obstacle. Rotate the platform controller until the directly above of the ultrasonic sensor in line with the obstacle.

64 Press the lift function enable button, press and hold the function enable button on the joystick, and slowly approach the obstacle.

- ⊙ Result: When the platform control is 2m away from the obstacle, the alarm will beep 110 times per minute, and the platform LED display shows "Ob".(Obstacle)

⊘ Result: When the platform control is 2m away from the obstacle, the anti-collision warning alarm will not sound (beep). Mark the machine immediately. And stop function.

65 Raise the platform while ensuring that the ultrasonic sensor moves in line with the obstacle.

- ⊙ Result: When the platform control is 1.5m away from the obstacle, the platform will stop the lift function, the alarm should continue to beep 110 times per minute, and the platform LED display shows "Ob". (Obstacle)

⊘ Result: When the platform control is 1.5m away from the obstacle, the anti-collision warning alarm (beep) does not sound, and the platform will continue to rise. Please mark the machine immediately. And stop function.

66 Release the joystick and raise the machine again within 5 seconds (within the time the alarm sounds).

- ⊙ Result: The platform will continue to raise, the alarm should continue to beeps 110 times per minute, and the platform LED display shows "Ob".(Obstacle)

67 Release the joystick and raise the machine again after 5 seconds (after the alarm stops).

- ⊙ Result: The lift function will be disabled and not allowed to raise, the alarm should sound continuously 110 beeps per minute, and the platform LED display shows "Ob".(Obstacle)

Note: The ultrasonic safety sensor will only protect the operator and platform directly above the platform control.

## Operating Instructions



### Do Not Operate Unless:

You learn and practice the principles of safe machine operation contained in this operator's manual.

- 1 Avoid hazardous situations.
- 2 Always perform a pre-operation inspection.
- 3 Inspect the workplace.
- 4 Always perform function tests prior to use.
- 5 **Only use the machine as it was intended.**

### Fundamentals

This machine is a self-propelled hydraulic lift equipped with a work platform on the scissor mechanism. Vibrations emitted by these machines are not hazardous to an operator in the work platform. The machine can be used to position personnel with their tools and supplies at position above ground level and can be used to reach work areas located above and over machinery or equipment.

A full and detailed implementation of EN ISO 13849-1/2 is correctly applied on our MEWP design. SISTEMA, a software tool for PL Calculation Tool, is also used to perform some relatively straightforward calculations on subsystem to determine the overall PL of the system. Reliability data, diagnostic coverage [DC], the system architecture [Category], common cause failure and, where relevant, requirements for software are used to assess the PL to comply with PLr of SRP/CS in Clause 5.11 of EN 280.

The Operating Instructions section provides instructions for each aspect of machine operation.

It is the operator's responsibility to follow all the safety rules and instructions in the operator's manual.

Using the machine for anything other than lifting personnel, along with their tools and materials, to an aerial work site is unsafe and dangerous.

Only trained and authorized personnel should be permitted to operate a machine. If more than one operator is expected to use a machine at different times in the same work shift, they must all be qualified operators and are all expected to follow all safety rules and instructions in the operator's manual. That means every new operator should perform a pre-operation inspection, function tests, and a workplace inspection before using the machine.

## Operating Instructions

### Emergency Stop

Push in the red Emergency Stop button to the off position at the ground controls or the platform controls to stop all machine functions.

Repair any function that operates when either red Emergency Stop button is pushed in.

### Emergency Lowering

- 1 Pull the emergency lowering knob.

### Operation from Ground

- 1 Be sure the battery pack is connected before operating the machine.
- 2 Turn the key switch to ground control.
- 3 Pull out the platform and ground red Emergency Stop button to the on position.

#### To Position Platform

- 1 At the control panel, press and hold the lift function enable button.
- 2 Press the platform up or down button.

Drive and steer functions are not available from the ground controls.

### Operation from Platform

- 1 Be sure the battery pack is connected before operating the machine.
- 2 Turn the key switch to platform control.
- 3 Pull out the platform and ground red Emergency Stop button to the on position.

#### To Position Platform

- 1 Press the lift function select button.
- 2 Press and hold the function enable switch on the control handle.
- 3 Move the control handle according to the markings on the control panel.

#### To Steer

- 1 Press the drive function select button.
- 2 Press and hold the function enable switch on the control handle.
- 3 Turn the steer wheels with the thumb rocker switch located on the top of the control handle.

#### To Drive

- 1 Press the drive function select button.
- 2 Press and hold the function enable switch on the control handle.
- 3 Increase speed: Slowly move the control handle off center.

Decrease speed: Slowly move the control handle toward center.

Stop: Return the control handle to center or release the function enable switch.

Use the color-coded direction arrows on the platform controls to identify the direction the machine will travel.

Machine travel speed is restricted when the platform is raised.

Battery condition will affect machine performance. Machine drive speed and function speed will drop when the battery level indicator is flashing.

#### To reduce drive speed

The drive controls can operate in two different drive speed modes. When the drive speed button light is on, slow drive speed mode is active. When the button light is off, fast drive speed mode is active.

Press the drive speed button to select the desired drive speed.

#### **▲ Driving on a slope**

Determine the slope and side slope ratings for the machine and determine the slope grade.

## Operating Instructions

JCPT0807, JCPT0808, JCPT0812, JCPT1012, JCPT1008, JCPT1212, JCPT1412, JCPT1612, JCPT1612S, maximum slope rating, stowed position 25%, maximum side slope rating, stowed position 25%.

Note: Slope rating is subject to ground conditions and adequate traction.

Press the drive speed button to the fast drive speed mode.

### To determine the slope grade

Measure the slope with a digital inclinometer OR use the following procedure.

You will need:

- Carpenter's level
- Straight piece of wood, at least 1 m long
- Tape measure

Lay the piece of wood on the slope.

At the downhill end, lay the level on the top edge of the piece of wood and lift the end until the piece of wood is level.

While holding the piece of wood level, measure the distance from the bottom of the piece of wood to the ground.

Divide the tape measure distance (rise) by the length of the piece of wood (run) and multiply by 100.

Example:

Run = 3.6 m

Rise = 0.3 m

$0.3 \text{ m} \div 3.6 \text{ m} = 0.083 \times 100 = 8.3\%$



If the slope exceeds the maximum slope or side slope rating, the machine must be winched or transported up or down the slope. See Transport and Lifting section.

### Operation from Ground with Controller

Maintain safe distances between operator, machine and fixed objects.

Be aware of the direction the machine will travel when using the controller.

### Battery Level Indicator



Use the LED readout screen to determine the battery level.

### How to use the Safety Arm

- 1 Raise the platform until the distance of the two sets of scissor at least 0.5m.
- 2 Lift the safety arm, move it to the center of the scissor arm and rotate up to a vertical position.
- 3 Lift the upper safety arm, move it to the center of the scissor arm and rotate down to a vertical position. (for JCPT1412, JCPT1612, JCPT1612S)
- 4 Lower the platform until the safety arm rests securely on the link. Keep clear of the safety arm when lowering the platform.

**⚠ DANGER** Engage all safety arms before performing maintenance or repair.

**⚠ DANGER** Don't engage the safety arm unless unload the platform.

## Operating Instructions

### How to Fold Down the Guardrails (JCPT0807)

The platform railing system consists of three fold down rail section for the extension deck and three sections for the main deck. All sections are held in place by four wire lock pins.

- 1 Fully lower the platform and retract the platform extension.
- 2 Remove the platform controls.
- 3 From inside the platform, remove the two front extension deck wire lock pins.
- 4 Fold down the front rail assembly. Keep hands clear of pinch points.
- 5 Replace the two removed pins back into each side rail bracket.
- 6 Fold down the extension platform right rail assembly. Keep hands clear of pinch points.
- 7 Fold down the extension platform left rail assembly. Keep hands clear of pinch points.
- 8 Carefully open the gate and move to the rear step or the ground.
- 9 From the rear step or from the ground, remove the right rear main deck wire lock pins.
- 10 Fold down the right rail assembly. Keep hands clear of pinch points.
- 11 Replace the removed pin back into rear rail bracket.
- 12 Remove the left rear main deck wire lock pins.
- 13 Fold down the left rail assembly. Keep hands clear of pinch points.
- 14 Replace the removed pin back into rear rail bracket.
- 15 Fold down the rear rail assembly. Keep hands free of pinch points.

### How to Fold Down the Guardrails (JCPT0808 ~ JCPT1612S)

The platform railing system consists of three fold down rail section for the extension deck and three sections for the main deck. All sections are held in place by four wire lock pins.

- 1 Fully lower the platform and retract the platform extension.
- 2 Remove the platform controls.
- 3 From inside the platform, remove the two front extension deck wire lock pins.
- 4 Fold down the front rail assembly. Keep hands clear of pinch points.
- 5 Replace the two removed pins back into each side rail bracket.
- 6 Fold down the extension platform left rail assembly. Keep hands clear of pinch points.
- 7 Fold down the extension platform right rail assembly. Keep hands clear of pinch points.
- 8 Carefully open the gate and move to the rear step or the ground.
- 9 From the rear step or from the ground, remove the left rear main deck wire lock pins.
- 10 Fold down the left rail assembly. Keep hands clear of pinch points.
- 11 Replace the removed pin back into rear rail bracket.
- 12 Remove the right rear main deck wire lock pins.
- 13 Fold down the right rail assembly. Keep hands clear of pinch points.
- 14 Replace the removed pin back into rear rail bracket.
- 15 Fold down the rear rail assembly. Keep hands free of pinch points.

## Operating Instructions

### How to Raise the Guardrails

Follow the fold down instructions but in reverse order.

### To Extend and Retract Platform

- 1 Press the platform lock pin pedal on the extension deck by foot.
- 2 Push the platform extension guardrail to extend the platform to the desired position.

Do not stand on the platform extension while trying to extend it.

### Anti-collision protection Safety function introduction (if equipped)

When the anti-collision protection function is activated, there are three levels of prompts (Danger Warnings).

- 1 When the Ultrasonic sensor (platform control panel) is 4 meters away from the obstacle zone, the machine will alarm (50 beeps per minute).
- 2 When the Ultrasonic sensor (platform control panel) is 2 meters away from the obstacle zone, the machine will alarm (110 beeps per minute).

Note: The above two levels do not limit the lift function.

- 3 When the Ultrasonic sensor (platform control panel) is 1.5 meters away from the obstacle zone, the lift function is disabled, and the alarm will be constant.

After the lift function is disabled, release the joystick back to neutral position (center) and operate the joystick to lift again within 5 seconds (within the time of the alarm sounding), with in this period the machine will

be enabled to lift again; at this point if not operated to lift again after 5 seconds (the alarm is relieved), the machine cannot be lifted and alarm sounds again.

Note: After the anti-collision protection function is triggered, the machine can only be operated by lowering the height of the platform or driving to an open position. Do not remove the ultrasonic sensor and the wiring harness connected to the platform control to relieve the limit.

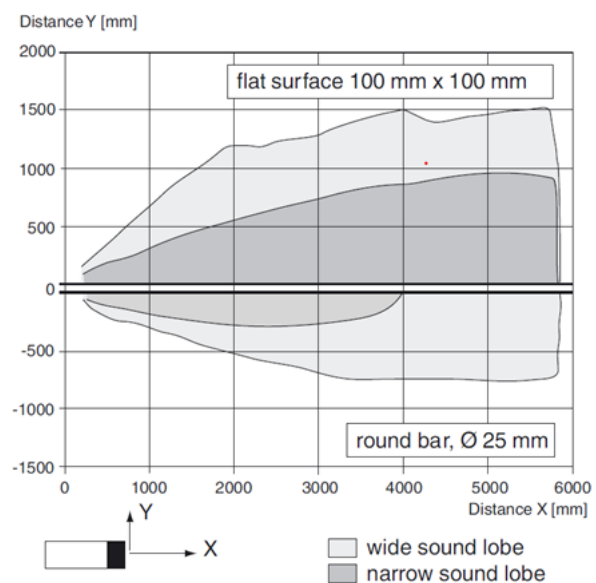

Sensor Characteristic Response Curve

(Default curve: wide sound lobe)

## Operating Instructions

### Error indicator readout



The LED readout screen displays fault codes that provide information about the machine operating status and about malfunctions. The fault codes listed in the following charts describe malfunctions and can aid in troubleshooting the machine by pinpointing the area or component affected.

#### List of Fault Codes

Display	Description	Lift Reaction
01	System Initialization Fault	Disables All Motion
02	System Communication Fault	Disables All Motion
03	Invalid Option Setting Fault	Disables All Motion
04	Calibration Fault	Warning Only
08	Key Switch Error	Disables All Motion
09	GPS Communication Fault	Warning Only
10	MC Communication Fault	Warning Only
11	BMS Communication Fault	Warning Only
12	Chassis Up or Down Switch ON	Disable Chassis Control
18	Pothole Guard Fault	Disable Lifting and Driving
31	31 Pressure Sensor Fault	Disables All Motion
32	32 Angle Sensor Fault	Disables All Motion
35	35 Pressure Sensor 2 Fault	Disables All Motion
36	36 Battery Drain Alarm	Drive speed limit
42	42 Platform Left Button ON	Warning Only
43	43 Platform Right Button ON	Warning Only
46	46 Platform Enable Button ON	Disable Platform Control
47	47 Joystick Not In Neutral	Drive speed limit
52	52 Drive Forward Coil Fault	Disable Lifting and Driving
53	53 Drive Reverse Coil Fault	Disable Lifting and Driving
54	54 Lift Up Coil Fault	Disable Lifting and Driving
55	55 Lift Down Coil Fault	Disable Lifting and Driving

**Operating Instructions**

<b>Display</b>	<b>Description</b>	<b>Lift Reaction</b>
56	56 Steer Right Coil Fault	Disable Lifting and Driving
57	57 Steer Left Coil Fault	Disable Lifting and Driving
59	59 Parallel Coil Fault	Disable Lifting and Driving
68	Battery Low Voltage	Disables All Motion
80	Platform Load is over 80%	Warning Only
90	Platform Load is over 90%	Warning Only
99	Platform Load is over 99%	Warning Only
OL	Platform Overloaded	Disable All Motion
LL	Machine Tiled	Disable Lifting and Driving
UP	Platform up limit position	Warning Only
102	Restore Parameters to Default	Warning Only
103	Battery is draining	Warning Only
104	Motor Controller Fault	Warning Only
105	BMS Alarm	Drive speed limit
106	BMS Fault	Disable All Motion
PCU: n1, ECU: 1xxx code	Left Drive Motor Controller Fault	Controller Dependent
PCU:n2, ECU: 2xxx code	Right Drive Motor Controller Fault	Controller Dependent
PCU: n3, ECU: 3xxx code	Pump Motor Controller Fault	Controller Dependent
PCU: n4, ECU:4xxx code	BMS Fault	BMS Dependent

**List of Fault Codes (motor controller)**

<b>Display</b>	<b>Description</b>	<b>Lift Reaction</b>
1008, 2008, 3008	WATCHDOG	Controller Dependent
1017, 2017, 3017	LOGIC FAILURE #3	Controller Dependent



## Operating Instructions

<b>Display</b>	<b>Description</b>	<b>Lift Reaction</b>
1018, 2018, 3018	LOGIC FAILURE #2	Controller Dependent
1019, 2019, 3019	LOGIC FAILURE #1	Controller Dependent
1028, 2028, 3028	PUMP VMN LOW	Controller Dependent
1029, 2029, 3029	PUMP VMN HIGH	Controller Dependent
1030, 2030, 3030	VMN LOW	Controller Dependent
1031, 2031, 3031	VMN HIGH	Controller Dependent
1037, 2037, 3037	CONTACTOR CLOSED	Controller Dependent
1038, 2038, 3038	CONTACTOR OPEN	Controller Dependent
1052, 2052, 3052	PUMP I=0 EVER	Controller Dependent
1053, 2053, 3053	STBY I HIGH	Controller Dependent
1060, 2060, 3060	CAPACITOR CHARGE	Controller Dependent
1062, 2062, 3062	TH. PROTECTION	Controller Dependent
1065, 2065, 3065	MOTOR TEMPERAT.	Controller Dependent
1066, 2066, 3066	BATTERY LOW	Controller Dependent
1074, 2074, 3074	DRIVER SHORTED	Controller Dependent
1075, 2075, 3075	CONTACTOR DRIVER	Controller Dependent
1078, 2078, 3078	VACC NOT OK	Controller Dependent
1079, 2079, 3079	INCORRECT START	Controller Dependent
1080, 2080, 3080	FORW + BACK	Controller Dependent
1086, 2086, 3086	PEDAL WIRE KO	Controller Dependent
1152, 2152, 3152	IIC BUS ERROR	Controller Dependent
1153, 2153, 3153	ENCODER ERROR XX	Controller Dependent
1154, 2154, 3154	OUT MISMATCHXX	Controller Dependent
1155, 2155, 3155	SP MISMATCHXX	Controller Dependent
1157, 2157, 3157	INPUT MISMATCHXX	Controller Dependent
1158, 2158, 3158	NOT RDY DRV.POW.	Controller Dependent
1159, 2159, 3159	HVIL FAIL	Controller Dependent

**Operating Instructions**

<b>Display</b>	<b>Description</b>	<b>Lift Reaction</b>
1160, 2160, 3160	SENS BAT TEMP KO	Controller Dependent
1161, 2161, 3161	RPM HIGH	Controller Dependent
1162, 2162, 3162	BUMPER STOP	Controller Dependent
1163, 2163, 3163	ED SLIP MISMATCH	Controller Dependent
1164, 2164, 3164	PWM ACQ. ERROR	Controller Dependent
1168, 2168, 3168	SIN/COS D.ERR XX	Controller Dependent
1169, 2169, 3169	ENCODER D.ERR XX	Controller Dependent
1170, 2170, 3170	WRONG KEY VOLT.	Controller Dependent
1171, 2171, 3171	ACQUIRING A.S.	Controller Dependent
1172, 2172, 3172	ACQUIRE ABORT	Controller Dependent
1173, 2173, 3173	ACQUIRE END	Controller Dependent
1174, 2174, 3174	OFFSET SPD.SENS.	Controller Dependent
1175, 2175, 3175	SPEED FB. ERROR	Controller Dependent
1176, 2176, 3176	HOME SENS.ERR XX	Controller Dependent
1177, 2177, 3177	COIL SHOR. EB.	Controller Dependent
1178, 2178, 3178	MOTOR TEMP. STOP	Controller Dependent
1179, 2179, 3179	STEER SENSOR KO	Controller Dependent
1180, 2180, 3180	OVERLOAD	Controller Dependent
1181, 2181, 3181	WRONG ENC SET	Controller Dependent
1185, 2185, 3185	TILLER ERROR	Controller Dependent
1186, 2186, 3186	WAIT MOT.P STILL	Controller Dependent
1187, 2187, 3187	LIFT+LOWER	Controller Dependent
1188, 2188, 3188	INT. CANBUSKO	Controller Dependent
1189, 2189, 3189	PUMP INC START	Controller Dependent
1190, 2190, 3190	PUMP VMN NOT OK	Controller Dependent
1191, 2191, 3191	PUMP VACC NOT OK	Controller Dependent
1192, 2192, 3192	PUMP VACC RANGE	Controller Dependent

## Operating Instructions

<b>Display</b>	<b>Description</b>	<b>Lift Reaction</b>
1193, 2193, 3193	SMARTDRIVER KO	Controller Dependent
1194, 2194, 3194	AUX BATT. SHORT.	Controller Dependent
1195, 2195, 3195	POS. EB. SHORTED	Controller Dependent
1196, 2196, 3196	MOT.PHASE SH.	Controller Dependent
1197, 2197, 3197	WRONG SLAVE VER.	Controller Dependent
1198, 2198, 3198	M/S PAR CHK MISM	Controller Dependent
1199, 2199, 3199	PARAM TRANSFER	Controller Dependent
1200, 2200, 3200	VDC OFF SHORTED	Controller Dependent
1201, 2201, 3201	TORQUE PROFILE	Controller Dependent
1202, 2202, 3202	VDC LINK OVERV.	Controller Dependent
1204, 2204, 3204	BRAKE RUN OUT	Controller Dependent
1205, 2205, 3205	EPS RELAY OPEN	Controller Dependent
1206, 2206, 3206	INIT VMN HIGH	Controller Dependent
1207, 2207, 3207	INIT VMN LOW	Controller Dependent
1208, 2208, 3208	EEPROM KO	Controller Dependent
1209, 2209, 3209	PARAM RESTORE	Controller Dependent
1210, 2210, 3210	WRONG RAM MEM.	Controller Dependent
1211, 2211, 3211	STALL ROTOR	Controller Dependent
1212, 2212, 3212	POWER MISMATCH	Controller Dependent
1213, 2213, 3213	POSITIVE LC OPEN	Controller Dependent
1214, 2214, 3214	EVP COIL OPEN	Controller Dependent
1215, 2215, 3215	EVP DRIV. SHORT.	Controller Dependent
1216, 2216, 3216	EB. COIL OPEN	Controller Dependent
1217, 2217, 3217	PEB NOT OK	Controller Dependent
1218, 2218, 3218	SENS MOT TEMP KO	Controller Dependent
1220, 2220, 3220	VKEY OFF SHORTED	Controller Dependent
1221, 2221, 3221	HANDBRAKE	Controller Dependent

**Operating Instructions**

<b>Display</b>	<b>Description</b>	<b>Lift Reaction</b>
1223, 2223, 3223	COIL SHOR.MC	Controller Dependent
1224, 2224, 3224	WAITING FOR NODE	Controller Dependent
1224, 2224, 3224	WAITING FOR NODE	Controller Dependent
1224, 2224, 3224	WAITING FOR NODE	Controller Dependent
1226, 2226, 3226	VACC OUT RANGE	Controller Dependent
1227, 2227, 3227	HW FAULT	Controller Dependent
1228, 2228, 3228	TILLER OPEN	Controller Dependent
1229, 2229, 3229	HW FAULT EB.	Controller Dependent
1230, 2230, 3230	LC COIL OPEN	Controller Dependent
1231, 2231, 3231	PUMP I NO ZERO	Controller Dependent
1232, 2232, 3232	CONT. DRV. EV	Controller Dependent
1233, 2233, 3233	POWERMOS SHORTED	Controller Dependent
1234, 2234, 3234	DRV. SHOR. EV	Controller Dependent
1235, 2235, 3235	CTRAP THRESHOLD	Controller Dependent
1236, 2236, 3236	CURRENT GAIN	Controller Dependent
1237, 2237, 3237	ANALOG INPUT	Controller Dependent
1238, 2238, 3238	HW FAULT EV.	Controller Dependent
1239, 2239, 3239	CONTROLLER MISM.	Controller Dependent
1240, 2240, 3240	EVP DRIVER OPEN	Controller Dependent
1241, 2241, 3241	COIL SHOR. EVAUX	Controller Dependent
1242, 2242, 3242	OPEN COIL EV.	Controller Dependent
1243, 2243, 3243	THROTTLE PROG.	Controller Dependent
1244, 2244, 3244	WARNING SLAVE	Controller Dependent
1245, 2245, 3245	IQMISMATCHED	Controller Dependent
1246, 2246, 3246	EB. DRIV.OPEN	Controller Dependent
1247, 2247, 3247	DATAACQUISITION	Controller Dependent
1248, 2248, 3248	NO CAN MSG.	Controller Dependent

## Operating Instructions

Display	Description	Lift Reaction
1249, 2249, 3249	CHECK UP NEEDED	Controller Dependent
1250, 2250, 3250	THERMIC SENS. KO	Controller Dependent
1251, 2251, 3251	WRONG SET BAT.	Controller Dependent
1253, 2253, 3253	FIELD ORIENT. KO	Controller Dependent
1254, 2254, 3254	EB. DRIV.SHRT.	Controller Dependent

### List of Fault Codes (Battery BMS)

Display	Description	Lift Reaction
4001	Low charging temperature 2	Lift and Drive speed limit
4002	Low charging temperature 3	Disables All Motion
4003	High charging temperature 2	Lift and Drive speed limit
4004	High charging temperature 3	Disables All Motion
4005	Low discharging temperature 2	Lift and Drive speed limit
4006	High discharging temperature 3	Disables All Motion
4007	Low discharging temperature 2	Lift and Drive speed limit
4008	High discharging temperature 3	Disables All Motion
4009	Temperature imbalance 2	Lift and Drive speed limit
4010	Temperature imbalance 3	Disables All Motion
4011	Pad Temperature high 2	Lift and Drive speed limit
4012	Pad Temperature high 3	Disables All Motion
4013	Low SOC 2	Lift and Drive speed limit
4014	Low SOC 3	Disables All Motion
4015	High SOC 2	Lift and Drive speed limit
4016	High SOC 3	Disables All Motion
4017	Discharge total voltage high 2	Lift and Drive speed limit
4018	Discharge total voltage high 3	Disables All Motion
4019	Discharge total voltage low 2	Lift and Drive speed limit

**Operating Instructions**

<b>Display</b>	<b>Description</b>	<b>Lift Reaction</b>
4020	Discharge total voltage low 3	Disables All Motion
4021	Charge total voltage high 2	Lift and Drive speed limit
4022	Charge total voltage high 3	Disables All Motion
4023	High charge current 2	Lift and Drive speed limit
4024	High charge current 3	Disables All Motion
4025	High discharge current 2	Lift and Drive speed limit
4026	High discharge current 2	Disables All Motion
4027	Discharge cell voltage high 2	Lift and Drive speed limit
4028	Discharge cell voltage high 3	Disables All Motion
4029	Discharge cell voltage low 2	Lift and Drive speed limit
4030	Discharge cell voltage low 3	Disables All Motion
4031	Charge cell voltage low 2	Lift and Drive speed limit
4032	Charge cell voltage low 3	Disables All Motion
4033	Cell voltage imbalance 2	Lift and Drive speed limit
4034	Cell voltage imbalance 3	Disables All Motion
4035	Main relay adhesion 2	Lift and Drive speed limit
4036	Main relay adhesion 3	Disables All Motion
4037	Heating relay adhesion 2	Lift and Drive speed limit
4038	Heating relay adhesion 3	Disables All Motion
4039	High monomer 2	Lift and Drive speed limit
4040	High monomer 3	Disables All Motion
4041	Low monomer 2	Lift and Drive speed limit
4042	Low monomer 3	Disables All Motion
4043	High temperature 2	Lift and Drive speed limit
4044	High temperature 3	Disables All Motion

For more information, please consult the appropriate Dingli Service Dept.

## Operating Instructions



### Battery and Charger Instructions

---

#### Observe and Obey:

- Do not use an external charger or booster battery.
- Charge the battery in a well-ventilated area.
- Use proper AC input voltage for charging as indicated on the charger.
- Use only a Dingli authorized battery and charger.
- Charge the battery as soon as receive the machine or after long distance transportation
- When the battery is stored for a long time, it needs to be charged regularly. Failure to charge in time may permanently damage the battery.

### To Charge Battery

- 1 Be sure the batteries are connected before charging.
- 2 Open the battery compartment. The compartment should remain open for the entire charging cycle.

#### Maintenance - free battery

- 3 Connect the battery charger to a grounded AC circuit.
- 4 The charger will indicate when the battery is fully charged.

#### Standard Battery

- 5 Remove the battery vent caps and check the battery acid level. If necessary, add only enough distilled water to cover the plates. Do not overfill prior to the charge cycle.
- 6 Replace the battery vent caps.
- 7 Connect the battery charger to a grounded AC circuit.
- 8 The charger will indicate when the battery is fully charged.
- 9 Check the battery acid level when the charging cycle is complete. Replenish with distilled water to the bottom of the fill tube. Do not overfill.

#### Lithium battery

- 10 During the charging operation, professional personnel should take care of it. During the charging process, the plug and socket should be in good contact, the charging equipment should work normally, and the connection points of the battery

## Operating Instructions

pack should be in good contact. If something goes wrong, it needs to be fixed before it can be charged.

- 11 During charging and discharging, try to avoid water or other conductive objects splashing on the battery cover and pole.
- 12 Avoid charging at low temperature (below 0 °C) to ensure battery life

### Dry Battery Filling and Charging Instructions

- 1 Remove the battery vent caps and permanently remove the plastic seal from the battery vent openings.
- 2 Fill each cell with battery acid (electrolyte) until the level is sufficient to cover the plates.

Do not fill to maximum level until the battery charge cycle is complete. Overfilling can cause the battery acid to overflow during charging. Neutralize battery acid spills with baking soda and water.

- 3 Install the battery vent caps.
- 4 Charge the battery.
- 5 Check the battery acid level when the charging cycle is complete. Replenish with distilled water to the bottom of the fill tube. Do not overfill.

Note: In order to achieve an optimal service life, discharge of over 60% of the rated capacity should be avoided. Discharge of over 80% of the rated capacity is a deep discharge and is not permissible. These significantly reduce the service life of the battery. Only those discharge state indicators that have been approved by the battery manufacturer may be used.

Discharged batteries must be charged immediately and must not remain in

discharged state. This also applies to batteries in a state of deep discharge. Otherwise, the service life of the battery will be significantly reduced. The battery may freeze when in discharged state

Charge the battery immediately when the machine displays "36" or "68" alarm code during work.

During the charging process, if temperatures are consistently higher than 40°C or lower than 15°C, stop charging to check whether the battery and charger are normal..



## Transport and Lifting Instructions



### Observe and Obey:

- ✓ Common sense and planning must be applied to control the movement of the machine when lifting it with a crane or forklift.
- ✓ Only qualified aerial lift operators should move the machine on or off the truck.
- ✓ The transport vehicle must be parked on a level surface.
- ✓ The transport vehicle must be secured to prevent rolling while the machine is being loaded.
- ✓ Be sure the vehicle capacity, loading surfaces and chains or straps are sufficient to withstand the machine weight. See the serial label for the machine weight.
- ✓ The machine must be on a level surface or secured before releasing the brakes.
- ✓ Do not allow the rails to fall when the snap pins are removed. Maintain a firm grasp on the rails when the rails are lowered.
- ✓ Do not drive the machine on a slope that exceeds the slope or side slope rating. See Driving on a Slope in the Operating Instructions section.
- ✓ If the slope of the transport vehicle bed exceeds the maximum slope rating, the machine must be loaded and unloaded using a winch as described.

### Brake Release Operation

#### For the Hydraulic Motor Drive Model

- 1 Chock the wheels to prevent the machine from rolling.
- 2 Be sure the winch line is properly secured to the drive chassis tie points and the path is clear of all obstructions.
- 3 Push in the black brake release knob to open the brake valve.
- 4 Pump the red brake release pump knob.
- 5 If you want to close the brake release, just pull out the black brake release knob.

#### For the Electric Motor Drive Model

- 1 Chock the wheels to prevent the machine from rolling.
- 2 Pull out the platform and emergency red Emergency Stop button to the on position.
- 3 Turn the key switch to the ground controller.
- 4 At the same time, long press the "Enter" button on the ECU panel to enter the the password input screen .
- 5 Press the "Menu enter button" 4 times to enter the Menu screen .
- 6 Press the "up" or "down" button to switch to the Special mode (" 4. Special Mode ")
- 7 Press the "Enter" button to display the Special mode. Press the "up" or "down" button to switch to the manual push menu (" 1. Brake Release ")
- 8 Press "Enter" button to display "long press to confirm release of brake". Long press the "enter" button to show "Brake

## Transport and Lifting Instructions

released!" Release all brakes

- 9 If you want to close the brake release, just turn off the key switch in "ground" position.

Towing the Hydraulic Drive Model is not recommended. If the machine must be towed, do not exceed 3.5 km/h.

Towing the Electric Motor Drive Model is not recommended. If the machine must be towed, do not exceed 4.0 km/h.

### Securing to Truck or Trailer for Transit

Always chock the machine wheels in preparation for transport.

Retract and secure the extension deck(s).

Turn the key switch to the off position and remove the key before transporting.

Inspect the entire machine for loose or unsecured items.

Use the tie-down points on the chassis for anchoring down to the transport surface.

Use a minimum of four chains or straps.

Use chains or straps of ample load capacity.

If the railings have been folded down, secure them with straps before transporting.

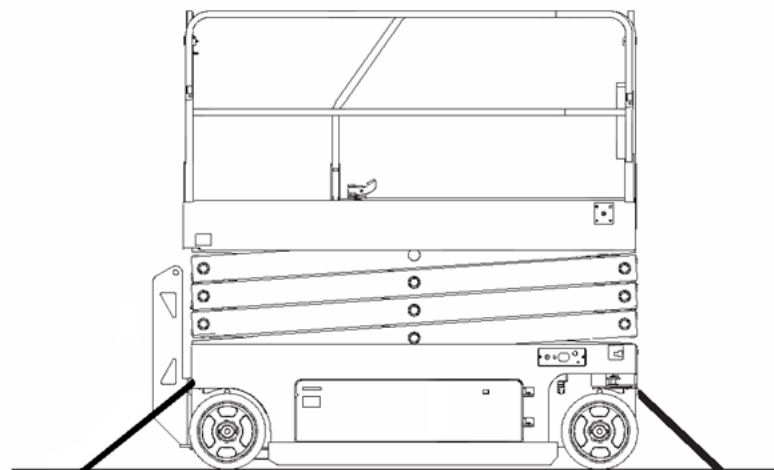
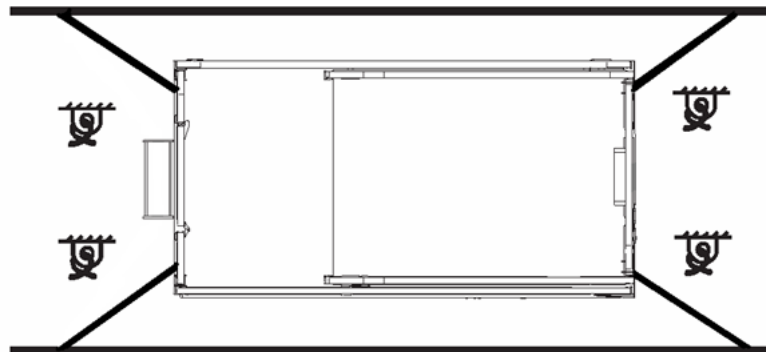

## Transport and Lifting Instructions



### Observe and Obey:

- Only qualified riggers should rig and lift the machine.
- Only qualified forklift operators should lift the machine with a forklift.
- Be sure the crane capacity, loading surfaces and straps or lines are sufficient to withstand the machine weight. See the serial plate for the machine weight.

### Lifting the Machine with a Forklift

Be sure the extension deck, controls and component trays are secure. Remove all loose items on the machine.

Fully lower the platform. The platform must remain lowered during all loading and transport procedures.

Use the forklift pockets located on both sides of the ladder.

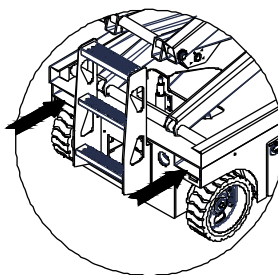

Position the forklift forks in position with the forklift pockets.

Drive forward to the full extent of the forks.

Raise the machine 15 cm and then tilt the forks back slightly to keep the machine secure.

Be sure the machine is level when lowering the forks.

#### **NOTICE**

Lifting the machine from the side can result in component damage.

# Transport and Lifting Instructions

## Lifting Instructions

Fully lower the platform. Be sure the extension decks, controls and covers are secure.

Remove all loose items on the machine.

Determine the center of gravity of your machine using the table and the picture on this page.

Attach the rigging only to the designated lifting points on the machine. There are two lifting points on each end of the machine.

Adjust the rigging to prevent damage to the machine and to keep the machine level.

## Center of gravity

Model	X Axis	Y Axis
JCPT0807HA JCPT0807AC	60 cm	59.1cm
JCPT0808HA JCPT0808AC	90.5 cm	56.5cm
JCPT0812HA JCPT0812AC	95.4 cm	64.7cm
JCPT1008HA JCPT1008AC	80.6cm	57.6cm
JCPT1012HA JCPT1012AC	89cm	64.4cm
JCPT1212HA JCPT1212AC	83cm	68.2cm
JCPT1412HA JCPT1412AC	83cm	72.1cm
JCPT1612HA JCPT1612AC	98cm	70.5cm
JCPT1612HAS JCPT1612ACS	93.7cm	80.2cm

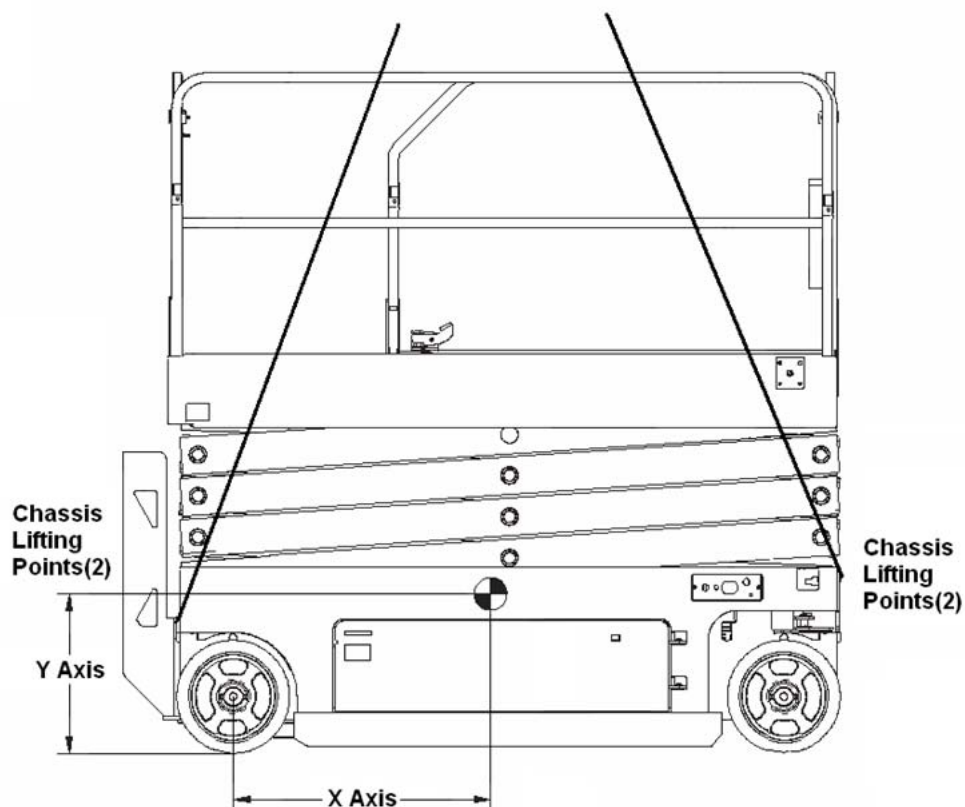

## Storage



### Observe and Obey:

The storage of the machine shall be as follows, Incorrect storage may affect the performance and service life of the machine

- 1 The machine should be stored indoor coeditor and the ground should be firm and level. If be stored in outdoor condition the machine should be covered to prevent the water and dust.
- 2 Ensure the machine have been cleaned and the functional before stop to the storage. Repair an maintain it if necessary.
- 3 Stop the machine in suitable position so as the drive or move the machines conveniently.

### Rust protection

- 1 Before the machine is stored into the storage. Inspecting the paint before the machine is stored into the storage repaint the machine partly all completely against the damage.
- 2 For moving parts grease can be applied to prevent rust, such as bearings, joints and sliding rails

**▲ CAUTION** The machine be stored long time cannot be used to service until it has been inspected and maintained according to the daily check procedure.

### How to store the batteries

- 1 When storing the machine for a long time (one month to six months) be sure to turn off the main power switch, key switch and emergency stop switch, fully charge. In order to ensure that these batteries stay ready for operation, the following charging procedures must be applied:
 

The machine or check the voltage of each battery on the machine once a month to ensure that the voltage of battery is not lower than 25.2V, otherwise please charge the machine immediately.
- 2 When storing the machine for a long time (half a year or more), should be fully charged state. The batteries should be removed from the machine. keep the batteries being clean and ensure nothing being placed on the top of batteries. The batteries connection should be disconnection as bellow. Disconnect the wire from the negative pole first the disconnect the wires from the positive pole. The batteries should be connected as bellow: First connect the positive power wires with the positive pole then connect the negative cable line to the negative pole finally. In order to ensure that these batteries stay ready for operation, the batteries should be charged one time in every quarter.

### Lithium battery storage

- 1 When storing the machine for a long time, be sure to turn off the main power switch, key switch and emergency stop switch and fully charge it
- 2 In order to avoid the loss of power and the impact on the service life of the battery, the

negative pole of the battery should be removed and the lithium battery should be charged regularly once a month

- 3 Lithium batteries should be stored in a dry, frost-free room.
- 4 Avoid contact between lithium batteries and corrosive objects, and keep away from places with fire sources and heat sources. The electrode should be insulated when stored (e.g. cover with protective cover) to ensure that no metal part is exposed to prevent short circuit.
- 5 If there are more than 10 groups of batteries in centralized storage, it is better to install a camera for 24-hour monitoring.

The following conditions can result in battery serious injuries:

- The battery was not charged in time when the machine displays "36" or "68" alarm code during work.
- Leave the Key Switch, Emergency Switch or Power Switch on.
- Forget to charge the battery regularly when storing the machine for a long time.

## Maintenance



### Observe and Obey:

- ✓ Only routine maintenance items specified in this manual shall be performed by the operator.
- ✓ Scheduled maintenance inspections shall be completed by qualified service technicians, according to the manufacturer's specifications and the requirements specified in this manual.

### Maintenance Symbols Legend

**NOTICE** The following symbols have been used in this manual to help communicate the intent of the instructions. When one or more of the symbols appear at the beginning of a maintenance procedure, it conveys the meaning below.



Indicates that tools will be required to perform this procedure.



Indicates that new parts will be required to perform this procedure.



Indicates that dealer service will be required to perform this procedure.

### Pre-delivery Preparation Report

The pre-delivery preparation report contains checklists for each type of scheduled inspection.

Make copies of the Pre-delivery Preparation report to use for each inspection. Store completed forms as required.

### Maintenance Schedule

There are five types of maintenance inspections that must be performed according to a schedule— daily, quarterly, semi-annually, annually, and two year. The Scheduled Maintenance Procedures Section and the Maintenance Inspection Report have been divided into five subsections—A, B, C, D, and E. Use the following chart to determine which group(s) of procedures are required to perform a scheduled inspection.

Inspection	Checklist
Daily or every 8 hours	A
Quarterly or every 250 hours	A+B
Semi-annually or every 500 hours	A+B+C
Annually or every 1000 hours	A+B+C+D
Two year or every 2000 hours	A+B+C+D+E

### Maintenance Inspection Report

The maintenance inspection report contains checklists for each type of scheduled inspection.

Make copies of the Maintenance Inspection Report to use for each inspection. Maintain completed forms for a minimum of 4 years or in compliance with your employer, jobsite and governmental regulations and requirements.

## Maintenance

### Pre-delivery Preparation Report

#### Fundamentals

It is the responsibility of the dealer to perform the Pre-delivery Preparation.

The Pre-delivery Preparation is performed prior to each delivery. The inspection is designed to discover if anything is apparently wrong with a machine before it is put into service.

A damaged or modified machine must never be used. If damage or any variation from factory delivered condition is discovered, the machine must be tagged and removed from service.

Repairs to the machine may only be made by a qualified service technician, according to the manufacturer's specifications.

Scheduled maintenance inspections shall be performed by qualified service technicians, according to the manufacturer's specifications and the requirements listed in this manual.

#### Instructions

Use the operator's manual on your machine.

The Pre-delivery Preparation consists of completing the Pre-operation Inspection, the Maintenance items and the Function Tests.

Use this form to record the results. Place a check in the appropriate box after each part is completed. Follow the instructions in the operator's manual.

If any inspection receives an N, remove the machine from service, repair and re-inspect it. After repair, place a check in the R box.

#### Legend

Y = yes, completed

N = no, unable to complete

R = repaired

#### Comments

Pre-Delivery Preparation	Y	N	R
Pre-operation inspection completed			
Maintenance items completed			
Function tests completed			

Model

Serial number

Date

Machine owner

Inspected by (print)

Inspector signature

Inspector title

Inspector company



# Maintenance

## Maintenance Inspection Report

<b>Model</b>
<b>Serial number</b>
<b>Date</b>
<b>Hour meter</b>
<b>Machine owner</b>
<b>Inspected by (print)</b>
<b>Inspector signature</b>
<b>Inspector title</b>
<b>Inspector company</b>
<b>Instructions</b>
<ul style="list-style-type: none"> <li>• Make copies of this report to use for each inspection.</li> <li>• Select the appropriate checklist(s) for the type of inspection to be performed.</li> </ul>
<input type="checkbox"/> Daily or 8 hours Inspection: <span style="float: right;">A</span>
<input type="checkbox"/> Quarterly or 250 hours Inspection: <span style="float: right;">A+B</span>
<input type="checkbox"/> Semi-annually or 500 hours Inspection: <span style="float: right;">A+B+C</span>
<input type="checkbox"/> Annually or 1000 hours Inspection: <span style="float: right;">A+B+C+D</span>
<input type="checkbox"/> Two year or 2000 hours Inspection: <span style="float: right;">A+B+C+D+E</span>
<ul style="list-style-type: none"> <li>• Place a check in the appropriate box after each inspection procedure is completed.</li> <li>• Use the step-by-step procedures in this section to learn how to perform these inspections.</li> <li>• If any inspection receives an "N", tag and remove the machine from service, repair and re-inspect it. After repair, place a check in the "R" box.</li> </ul>
<b>Legend</b>
Y = yes, acceptable
N = no, remove from service
R = repaired

<b>Checklist A</b>	Y	N	R
A-1 Inspect the manuals and decals			
A-2 Pre-operation inspection			
A-3 Check the Batteries			
A-4 Check the Hydraulic Oil Level			
A-5 Function tests			
<b>Perform after 40 hours:</b>			
A-6 30 day service			
<b>Checklist B</b>	Y	N	R
B-1 Batteries			
B-2 Electrical wiring			
B-3 Tires and wheels			
B-4 Emergency stop			
B-5 Key switch			
B-6 Horn (if equipped)			
B-7 Drive brakes			
B-8 Drive speed - stowed			
B-9 Drive speed - raised			
B-10 Drive speed - slow			
B-11 Hydraulic oil analysis			
B-12 Tank venting system			
B-13 Latch components			
B-14 Test the pothole limit switches and the level Sensor			
<b>Checklist C</b>	Y	N	R
C-1 Platform overload (if equipped)			
C-2 Breather cap - models with optional oil			
<b>Checklist D</b>	Y	N	R
D-1 Scissor arm wear pads			
D-2 Hydraulic filter			
<b>Checklist E</b>	Y	N	R
E-1 Hydraulic oil			

## Checklist A Procedures

### A-1

#### Inspect the Manuals and Decals

Maintaining the operator's manual in good condition is essential to safe machine operation. Manuals are included with each machine and should be stored in the container provided in the platform. An illegible or missing manual will not provide safety and operational information necessary for a safe operating condition.

In addition, maintaining all of the safety and instructional decals in good condition is mandatory for safe machine operation. Decals alert operators and personnel to the many possible hazards associated with using this machine. They also provide users with operation and maintenance information. An illegible decal will fail to alert personnel of a procedure or hazard and could result in unsafe operating conditions.

- 1 Check to make sure that the operator's manual is present and complete in the storage container on the platform.
- 2 Examine the pages of manual to be sure that they are legible and in good condition.

⊙ Result: The operator's manual is appropriate for the machine and the manual are legible and in good condition.

⊘ Result: The operator's manual is not appropriate for the machine or the manual is not in good condition or is illegible. Remove the machine from service until the manual is replaced.

- 3 Open the operator's manual to the decals inspection section. Carefully and thoroughly inspect all decals on the machine for legibility and damage.

⊙ Result: The machine is equipped with all required decals, and all decals are legible and in good condition.

⊘ Result: The machine is not equipped with all required decals, or one or more decals are illegible or in poor condition. Remove the machine from service until the decals are replaced.

- 4 Always return the manual to the storage container after use.

Note: Contact your authorized DINGLI distributor or DINGLI machinery if replacement manuals or decals are needed.

## Maintenance

### A-2

#### Perform Pre-operation Inspection

Completing a Pre-operation Inspection is essential to safe machine operation. The Pre-operation Inspection is a visual inspection performed by the operator prior to each work shift. The inspection is designed to discover if anything is apparently wrong with a machine before the operator performs the function tests. The Pre-operation Inspection also serves to determine if routine maintenance procedures are required.

Complete information to perform this procedure is available in the appropriate operator's manual. Refer to the operator's manual on your machine.

### A-3

#### Check the Batteries



Proper battery condition is essential to good machine performance and operational safety. Improper fluid levels or damaged cables and connections can result in component damage and hazardous conditions.

Note: This check is not required for machines with lithium batteries, sealed batteries, or Maintenance - free batteries.

**⚠ WARNING** Electrocutation hazard.

Contact with hot or live circuits may result in death or serious injury. Remove all rings, watches and other jewelry.

**⚠ WARNING** Bodily injury hazard.

Batteries contain acid. Avoid spilling or contacting battery acid. Neutralize battery acid spills with baking soda and water.

- 1 Put on protective clothing and eye wear.
- 2 Be sure that the battery cable connections are tight and free of corrosion.
- 3 Be sure that the battery hold-down bars are secure.
- 4 Remove the battery vent caps.
- 5 Check the battery acid level. If needed, replenish with distilled water to the bottom of the battery fill tube. Do not overfill.
- 6 Install the vent caps.

## Maintenance

### A-4

#### Check the Hydraulic Oil Level



Maintaining the hydraulic oil at the proper level is essential to machine operation. Improper hydraulic oil levels can damage hydraulic components. Daily checks allow the inspector to identify changes in oil level that might indicate the presence of hydraulic system problems.

#### NOTICE

Perform this procedure with the platform in the stowed position.

- 1 Visually inspect the sight of hydraulic oil level from the side of the hydraulic oil tank.

⊙ Result: The hydraulic oil level should be at the mark of the fuel tank. (Refer to the following table).

Model	Scale line (L)
JCPT0807HA/AC	5.5
JCPT0808HA/AC JCPT0812HA/AC JCPT1008HA/AC JCPT1012HA/AC	15
JCPT1212HA/AC JCPT1412HA/AC	17.5
JCPT1612HA/AC JCPT1612HAS/ACS	19

- 2 Add oil if necessary. Do not overfill.

#### NOTICE

**Original Hydraulic oil specifications: L-HV46**

Customers shall choose the appropriate hydraulic oil according to the ambient temperature used.

Example: L-HV32 or L-HV68

### A-5

#### Perform Function Tests

Completing the function tests is essential to safe machine operation. Function tests are designed to discover any malfunctions before the machine is put into service. A malfunctioning machine must never be used. If malfunctions are discovered, the machine must be tagged and removed from service.

Complete information to perform this procedure is available in the appropriate operator's manual. Refer to the operator's manual on your machine.

### A-6

#### Perform 30 Day Service



The 30 day maintenance procedure is a one time procedure to be performed after the first 30 days or 40 hours of usage. After this interval, refer to the maintenance tables for continued scheduled maintenance.

Perform the following maintenance procedures:

- B-3 Inspect the Tires, Wheels and Castle Nut Torque
- D-2 Replace the Hydraulic Tank Return Filter Element

# Maintenance

## Checklist B Procedures

### B-1

#### Inspect the Batteries



DINGLI requires that this procedure be performed every 250 hours or quarterly, whichever comes first.

Proper battery condition is essential to good machine performance and operational safety. Improper fluid levels or damaged cables and connections can result in component damage and hazardous conditions.

**⚠ WARNING** Electrocutation / burn hazard. Contact with electrically charged circuits could result in death or serious injury. Remove all rings, watches and other jewelry.

**⚠ WARNING** Bodily injury hazard. Batteries contain acid. Avoid spilling or contacting battery acid. Neutralize battery acid spills with baking soda and water.

- 1 Put on protective clothing and eye wear.
- 2 Release the battery pack latch and rotate the battery pack out and away from the chassis.
- 3 Be sure that the battery cable connections are free of corrosion.

Note: Adding terminal protectors and a corrosion preventative sealant will help eliminate corrosion on the battery terminals and cables.

- 4 Be sure that the battery retainers and cable connections are tight.
- 5 Fully charge the batteries. Allow the batteries to rest 24 hours before performing this procedure to allow the battery cells to equalize.

#### Models without maintenance-free or sealed batteries:

- 6 Remove the battery vent caps and check the specific gravity of each battery cell with a hydrometer. Note the results.
- 7 Check the ambient air temperature and adjust the specific gravity reading for each cell as follows:
  - Add 0.004 to the reading of each cell for every 5.5° C above 26.7° C.
  - Subtract 0.004 from the reading of each cell for every 5.5° C below 26.7° C.
- ⊙ Result: All battery cells display an adjusted specific gravity of 1.277 or higher. The battery is fully charged. Proceed to step 11.
- ⊗ Result: One or more battery cells display a specific gravity of 1.217 or below. Proceed to step 8.
- 8 Perform an equalizing charge OR fully charge the batteries and allow the batteries to rest at least 6 hours.
- 9 Remove the battery vent caps and check the specific gravity of each battery cell with a hydrometer. Note the results.
- 10 Check the ambient air temperature and adjust the specific gravity reading for each cell as follows:
  - Add 0.004 to the reading of each cell for every 5.5° C above 26.7° C.
  - Subtract 0.004 from the reading of each cell for every 5.5° C below 26.7° C.
- ⊙ Result: All battery cells display a specific gravity of 1.277 or greater. The battery is

## Maintenance

fully charged. Proceed to step 11.

- ☐ Result: The difference in specific gravity readings between cells is greater than 0.1  
OR the specific gravity of one or more cells is less than 1.177. Replace the battery.
- 11 Check the battery acid level. If needed, replenish with distilled water to 3 mm below the bottom of the battery fill tube. Do not overfill.
- 12 Install the vent caps and neutralize any electrolyte that may have spilled.

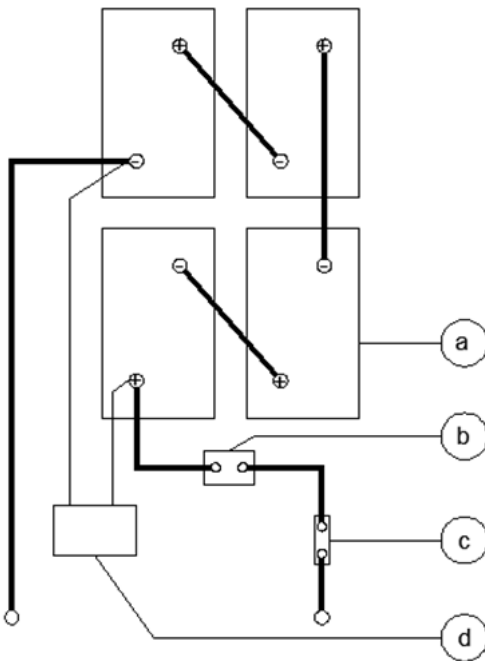

Apply to JCPT0807/JCPT0808/  
JCPT0812/JCPT1008/JCPT1012  
(Hydraulic Motor / AC Motor Drive)

- a 6V batteries
- b power switch
- c fuse
- d battery charger

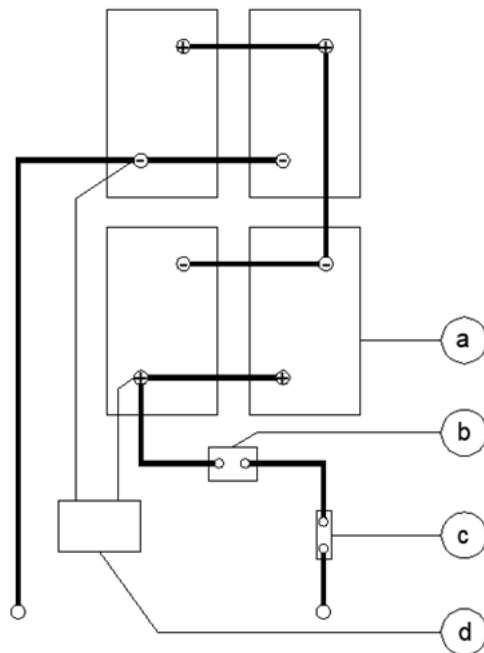

Apply to  
JCPT1212/JCPT1412/JCPT1612/JCPT1612S  
(Hydraulic Motor / AC Motor Drive)

- a 12V batteries
- b power switch
- c fuse
- d battery charger

### Suitable for lithium batteries

- 13 The connection between the electrode and the data should be fastened. There should be no dirt, metal dust or other dirt at the connection. If there is any, compressed air should be used to clean it
- 14 Make sure the battery is reliable and stable
- 15 The battery pack should not be cracked, bulging, deformed, pole loose and other abnormal conditions
- 16 Battery voltage, temperature and other states should also be checked before use to ensure that all values are within the normal range before starting up for use
- 17 It is forbidden to use the battery over discharge to ensure that the cell voltage of the unit is not lower than 2V

## Maintenance

### All models:

- 18 Check each battery pack and verify that the batteries are wired correctly.
  - 19 Inspect the battery charger plug and pigtail for damage or excessive insulation wear. Replace as required.
  - 20 Connect the battery charger to a properly grounded 110 - 230V / 50 – 60 Hz single phase AC power supply.
- ⊙ Result: The charger should operate and begin charging the batteries.
- ⊗ Result: If, simultaneously, the charger alarm sounds and the LEDs blink, correct the charger connections at the fuse and battery. The charger will then operate correctly and begin charging the batteries.

Note: For best results, use an extension of adequate size with a length no longer than 15m.

The following must be measured and recorded once the battery has been fully charged, after a waiting time of at least 12 hours:

- Total voltage
- Individual voltage of the block battery

If significant changes to previous measurements or differences between the block batteries are identified, then customer service must be contacted for further testing or repairs.

Note: If you have any further questions regarding the battery charger operation, please contact the DINGLI Service Department.

**B-2****Inspect the Electrical Wiring**

DINGLI requires that this procedure be performed every 250 hours or quarterly, whichever comes first.

Maintaining electrical wiring in good condition is essential to safe operation and good machine performance. Failure to find and replace burnt, chafed, corroded or pinched wires could result in unsafe operating conditions and may cause component damage.

**⚠ WARNING** Electrocutation / burn hazard. Contact with electrically charged circuits could result in death or serious injury. Remove all rings, watches and other jewelry.

- 1 Inspect the underside of the chassis for damaged or missing ground strap(s).
- 2 Inspect the following areas for burnt, chafed, corroded and loose wires:
  - Ground control panel
  - Hydraulic power unit module tray
  - Battery pack module tray
  - Platform controls
- 3 Turn the key switch to ground control. Turn the ground red Emergency Stop button clockwise to the on position. Pull out the platform red Emergency Stop button to the on position.
- 4 Raise the platform until the distance of the two sets of scissor at least 0.5m.
- 5 Lift the safety arm, move it to the center of the scissor arm and rotate up to a vertical position.
- 6 Lift the upper safety arm, move it to the center of the scissor arm and rotate down to a vertical position. (for JCPT1412, JCPT1612).
- 7 Lower the platform until the safety arm rests securely on the link. Keep clear of the safety arm when lowering the platform.
 

**⚠ WARNING** Crushing hazard. Keep hands clear of the safety arm when lowering the platform.
- 8 Inspect the center chassis area and scissor arms for burnt, chafed and pinched cables.
- 9 Inspect the following areas for burnt, chafed, corroded, pinched and loose wires:
  - Scissor arms
  - ECU to platform controls
  - Power to platform wiring
- 10 Inspect for a liberal coating of dielectric grease in the following locations:
  - Between the ECU and platform controls
  - All wire harness connectors Level sensor
- 11 Raise the platform and return the safety arm to the stowed position.
- 12 Lower the platform to the stowed position and turn the machine off.



## Maintenance

### B-3

#### Inspect the Tires and Wheels (including castle nut torque)



DINGLI requires that this procedure be performed every 250 hours or quarterly, whichever comes first.

Maintaining the tires and wheels in good condition is essential to safe operation and good performance. Tire and/or wheel failure could result in a machine tip-over. Component damage may also result if problems are not discovered and repaired in a timely fashion.

- 1 Check the tire surface and sidewalls for cuts, cracks, punctures and unusual wear.
- 2 Check each wheel for damage, bends and cracks.

#### For HA model machine

- 3 Remove the cotter pin and check each castle nut for proper torque.

Note: Always replace the cotter pin with a new one when removing the castle nut or when checking the torque of the castle nut.

- 4 Install a new cotter pin. Bend the cotter pin to lock it in place.

---

Castle nut torque, dry	406.7Nm
------------------------	---------

---

Castle nut torque, lubricated	305Nm
-------------------------------	-------

---

#### For AC model machine

- 3 Check each bolt for proper torque.

---

Bolt torque, dry	125Nm
------------------	-------

---

Bolt torque, lubricated	115Nm
-------------------------	-------

---

### B-4

#### Test the Emergency Stop

DINGLI requires that this procedure be performed every 250 hours or quarterly, whichever comes first.

A properly functioning Emergency Stop is essential for safe machine operation. An improperly operating red Emergency Stop button will fail to shut off power and stop all machine functions, resulting in a hazardous situation.

As a safety feature, selecting and operating the ground controls will override the platform controls, except the platform red Emergency Stop button.

- 1 Turn the key switch to ground control. Pull out the platform and ground red Emergency Stop button to the on position.
  - 2 Push in the red Emergency Stop button at the ground controls to the off position.
- ⊙ Result: No machine functions should operate.
- 3 Turn the key switch to platform control. Pull out the platform and ground red Emergency Stop button to the on position.
  - 4 Push in the red Emergency Stop button at the platform controls to the off position.

⊙ Result: No machine functions should operate.

Note: The red Emergency Stop button at the ground controls will stop all machine operation, even if the key switch is switched to platform control.

## Maintenance

### B-5

#### Test the Key Switch

DINGLI requires that this procedure be performed every 250 hours or quarterly, whichever comes first.

Proper key switch action and response is essential to safe machine operation. The machine can be operated from the ground or platform controls and the activation of one or the other is accomplished with the key switch. Failure of the key switch to activate the appropriate control panel could cause a hazardous operating situation.

Perform this procedure from the ground using the platform controls. Do not stand in the platform.

- 1 Pull out the platform and ground red Emergency Stop button to the on position.
- 2 Turn the key switch to platform control.
- 3 Check the platform up/down function from the ground controls.

⊙ Result: The machine functions should not operate.

- 4 Turn the key switch to ground control.
- 5 Check the machine functions from the platform controls.

⊙ Result: The machine functions should not operate.

- 6 Turn the key switch to the off position.

⊙ Result: No function should operate.

### B-6

#### Test the Automotive-style Horn (if equipped)

DINGLI requires that this procedure be performed every 250 hours or quarterly, whichever comes first.

The horn is activated at the platform controls and sounds at the ground as a warning to ground personnel. An improperly functioning horn will prevent the operator from alerting ground personnel of hazards or unsafe conditions.

- 1 Turn the key switch to platform control. Pull out the platform and ground red Emergency Stop button to the on position.
- 2 Push down the horn button at the platform controls.

⊙ Result: The horn should sound.

# Maintenance

## B-7

### Test the Drive Brakes



DINGLI requires that this procedure be performed every 250 hours or quarterly, whichever comes first.

Proper brake action is essential to safe machine operation. The drive brake function should operate smoothly, free of hesitation, jerking and unusual noise.

Hydraulically-released individual wheel brakes can appear to operate normally when not fully operational.

Perform this procedure with the machine on a firm level surface that is free of obstructions, with the platform extension deck fully retracted and the platform in the stowed position.

- 1 Mark a test line on the ground for reference.
- 2 Turn the key switch to platform control. Pull out the platform and ground red Emergency Stop button to the on position.
- 3 Lower the platform to the stowed position.
- 4 Press the drive function select button.
- 5 Choose a point on the machine; i.e., contact patch of a tire, as a visual reference for use when crossing the test line.
- 6 Bring the machine to top drive speed before reaching the test line. Release the function enable switch or the joystick when your reference point on the machine crosses the test line.
- 7 Measure the distance between the test line and your machine reference point.

⊙ Result: The machine stops within the specified braking distance. No action required.

⊗ Result: The machine does not stop within the specified braking distance.

Note: The brakes must be able to hold the machine on any slope it is able to climb.

- 8 Replace the brakes and repeat this procedure beginning with step 1.

---

#### Braking distance, maximum

---

High range on paved surface    61cm±30cm

---

**B-8****Test the Drive Speed - Stowed Position**

DINGLI requires that this procedure be performed every 250 hours or quarterly, whichever comes first.

Proper drive functions are essential to safe machine operation. The drive function should respond quickly and smoothly to operator control. Drive performance should also be free of hesitation, jerking and unusual noise over the entire proportionally controlled speed range.

Perform this procedure with the machine on a firm, level surface that is free of obstructions.

- 1 Create start and finish lines by marking two lines on the ground 12.2 m apart.
- 2 Turn the key switch to platform control. Pull out the platform and ground red Emergency Stop button to the on position.
- 3 Lower the platform to the stowed position.
- 4 Press the drive function select button.
- 5 Choose a point on the machine; i.e., contact patch of a tire, as a visual reference for use when crossing the start and finish lines.
- 6 Bring the machine to top drive speed before reaching the start line. Begin timing when your reference point on the machine crosses the start line.
- 7 Continue at full speed and note the time when your reference point on the machine passes over the finish line. Refer to specifications.

**B-9****Test the Drive Speed - Raised Position**

DINGLI requires that this procedure be performed every 250 hours or quarterly, whichever comes first.

Proper drive functions are essential to safe machine operation. The drive function should respond quickly and smoothly to operator control. Drive performance should also be free of hesitation, jerking and unusual noise over the entire proportionally controlled speed range.

Perform this procedure with the machine on a firm, level surface that is free of obstructions.

- 1 Create start and finish lines by marking two lines on the ground 12.2 m apart.
- 2 Turn the key switch to platform control. Pull out the platform and ground red Emergency Stop button to the on position.
- 3 Press the lift function select button.
- 4 Press and hold the function enable switch on the joystick.
- 5 Raise the platform approximately 2 m from the ground.
- 6 Press the drive function select button.
- 7 Choose a point on the machine; i.e., contact patch of a tire, as a visual reference for use when crossing the start and finish lines.
- 8 Bring the machine to top drive speed before reaching the start line. Begin timing when your reference point on the machine crosses the start line.
- 9 Continue at full speed and note the time when your reference point on the machine passes over the finish line. Refer to specifications.

## Maintenance

### B-10

#### Test the Slow Drive Speed



DINGLI requires that this procedure be performed every 250 hours or quarterly, whichever comes first.

Proper drive functions are essential to safe machine operation. The drive function should respond quickly and smoothly to operator control. Drive performance should also be free of hesitation, jerking and unusual noise over the entire proportionally controlled speed range.

Perform this procedure with the machine on a firm, level surface that is free of obstructions.

- 1 Create start and finish lines by marking two lines on the ground 12.2 m apart.
- 2 Turn the key switch to platform control. Pull out the platform and ground red Emergency Stop button to the on position.
- 3 Lower the platform to the stowed position.
- 4 Press the slow speed select button.
- 5 Choose a point on the machine; i.e., contact patch of a tire, as a visual reference for use when crossing the start and finish lines.
- 6 Bring the machine to top drive speed before reaching the start line. Begin timing when your reference point on the machine crosses the start line.
- 7 Continue at full speed and note the time when your reference point on the machine passes over the finish line. The time is less than 25 sec.

### B-11

#### Perform Hydraulic Oil Analysis



DINGLI requires that this procedure be performed every 250 hours or quarterly, whichever comes first.

Replacement or testing of the hydraulic oil is essential for good machine performance and service life. Dirty oil may cause the machine to perform poorly and continued use may cause component damage. Extremely dirty conditions may require oil changes to be performed more often.

Before replacing the hydraulic oil, the oil may be tested by an oil distributor for specific levels of contamination to verify that changing the oil is necessary.

If the hydraulic oil is not replaced at the two year inspection, test the oil quarterly. Replace the oil when it fails the test. See E-1, Test or Replace the Hydraulic Oil.

**B-12****Inspect the Hydraulic Tank Cap Venting System**

DINGLI requires that this procedure be performed quarterly or every 250 hours, whichever comes first. Perform this procedure more often if dusty conditions exist.

A free-breathing hydraulic tank cap is essential for good machine performance and service life. A dirty or clogged cap may cause the machine to perform poorly. Extremely dirty conditions may require that the cap be inspected more often.

- 1 Remove the breather cap from the hydraulic tank.
  - 2 Check for proper venting.
- ☉ Result: Air passes through the breather cap.
- ☒ Result: If air does not pass through the cap, clean or replace the cap. Proceed to step 3.

**Note:** When checking for positive tank cap venting, air should pass freely through the cap.

- 3 Using a mild solvent, carefully wash the cap venting system. Dry using low pressure compressed air. Repeat step 2.
- 4 Install the breather cap onto the hydraulic tank.

**B-13****Check the Module Tray Latch Components**

DINGLI requires that this procedure be performed every 250 hours or quarterly, whichever comes first.

Maintaining the module tray latch components in good condition is essential to good performance and service life. Failure to detect worn out latch components may result in module trays opening unexpectedly, creating an unsafe operating condition.

- 1 Inspect each module tray rotary latch and related components for wear. Tighten any loose fasteners.
- 2 Lubricate each module tray rotary latch. Using light oil, apply a few drops to each of the springs and to the sides of the rotary latch mechanism.

## Maintenance

### B-14

#### Test the Pothole Limit Switches and the Level Sensor



DINGLI requires that this procedure be performed every 250 hours or quarterly, whichever comes first.

Maintaining the limit switches is essential to safe operation and good machine performance. Operating the machine with a faulty limit switch could result in reduced machine performance and a potentially unsafe operating condition.

Perform these procedures with the machine on a firm, level surface that is free of obstructions.

#### Level sensor

- 1 Remove the platform controls from the platform.
  - 2 Turn the key switch to platform control. Pull out the platform and ground red Emergency Stop button to the on position.
  - 3 Press the drive function select button
  - 4 Move the machine onto a grade which exceeds the rating of the level sensor. Refer to the serial label on the machine.
  - 5 Press the lift function select button. Standing on the up-hill side of the machine, attempt to raise the platform to approximately 2.4 m.
- ⊙ Result: The LED readout screen shows code LL, an alarm sounds, and the machine stops lifting after the pothole guards are deployed. The machine is functioning properly.

⊗ Result: The LED readout screen does not show code LL, the alarm does not sound and the machine will continue to lift the platform after the pothole guards are deployed. Adjust or replace the level sensor.

- 6 Press the drive function select button. Standing on the up-hill side of the machine, attempt to steer and drive the machine.
- ⊙ Result: The LED readout screen shows code LL, an alarm sounds, and the machine will not steer or drive. The machine is functioning properly.

⊗ Result: The LED readout screen does not show code LL, the alarm does not sound and the steer and drive functions operate. Adjust or replace the level sensor.

#### Pothole Limit Switches

- 7 Lower the platform to the stowed position. Move the machine onto a firm, level surface.
  - 8 Place a wooden block approximately 5 cm tall under the right pothole guard.
  - 9 Press the lift function select button. Attempt to raise the platform approximately 2.4m.
- ⊙ Result: The pothole guard contacts the block and does not fully deploy, the LED readout screen shows code 18, an alarm sounds and the platform will lift to 2.4m or beyond. The machine is functioning properly.

**Maintenance**

- ⊗ Result: The pothole guard contacts the block and does not fully deploy, the LED readout screen does not show code 18, the alarm does not sound and the machine will continue to lift the platform after the pothole guards are deployed. Adjust or replace the pothole limit switch.
- 10 Press the drive function select button.  
Attempt to steer or drive the machine.
- ⊙ Result: The LED readout screen shows code 18, an alarm sounds, and the machine will not steer or drive. The machine is functioning properly.
  - ⊗ Result: The LED readout screen does not show code 18, the alarm does not sound and the steer and drive functions operate. Adjust or replace the down limit switch.
- 11 Lower the platform to the stowed position and remove the block under the right pothole guard.
  - 12 Repeat this procedure beginning with step 34 for the left pothole guard.
  - 13 Lower the platform to the stowed position, remove the block under the left pothole guard.
  - 14 Turn off the machine.



## Maintenance

### Checklist C Procedures

#### C-1

#### Test the Platform Overload System (if equipped)



DINGLI requires that this procedure be performed every 500 hours or six months, whichever comes first or when the machine fails to lift the maximum rated load.

Testing the platform overload system regularly is essential to safe machine operation. Continued use of an improperly operating platform overload system could result in the system not sensing an overloaded platform condition. Machine stability could be compromised resulting in the machine tipping over.

The platform overload system is designed to prevent machine operation in the event the platform is overloaded. Models equipped with the platform overload option are provided with two additional machine control components: the overload pressure sensor and the platform height sensor.

The overload pressure transducer, located at the valve of the lift cylinder, is used to determine the pressure inside the lift cylinder.

The platform height sensor, located at the steer end of the chassis, battery side, is used to determine the height of the platform.

The overload pressure transducer and the platform height sensor provide the GCON with necessary information to determine the load in the platform.

**Note:** The overload system will not measure loads at or below the height of the Down Limit.

**Note:** Perform this test from the ground with the platform controller. Do not stand in the platform.

**⚠ WARNING** Perform this procedure with the machine on a firm, level surface.

- 1 Turn the key switch to platform controls.  
Pull out the platform and ground red Emergency Stop button to the on position.
- 2 Determine the maximum platform capacity.
- 3 Using a suitable lifting device, place an appropriate test weight equal to the maximum platform capacity in the center of the platform floor. Raise the platform.
  - ⊙ Result: The overload alarm not sounds during the whole trip, indicating a normal condition.
  - ⊗ Result: The overload alarm sounds during the whole trip. Calibrate the platform overload system.
- 4 The platform should lower to the stowed position
- 5 Add an additional weight to the platform not to exceed 20% of the maximum rated load. Raise the platform.
  - ⊙ Result: The overload alarm at the platform controls sound, indicating a normal condition.
  - ⊗ Result: The overload alarm at the platform controls does not sound. Calibrate the platform overload system.
- 6 Test all machine functions from the platform controls.
  - ⊙ Result: All platform control functions should not operate.

## Maintenance

- 7 Turn the key switch to ground control.
- 8 Test all machine functions from the ground controls
- ⊙ Result: All ground control functions should not operate.
- 9 Lift the test weight off the platform floor using a suitable lifting device.
- 10 The platform should lower to the stowed position.

### C-2

#### Replace the Hydraulic Tank Breather Cap



DINGLI requires that this procedure be performed every 500 hours or semi-annually, whichever comes first.

The hydraulic tank is a vented-type tank. The breather cap has an internal air filter that can become clogged or, over time, can deteriorate. If the breather cap is faulty or improperly installed, impurities can enter the hydraulic system which may cause component damage. Extremely dirty conditions may require that the cap be inspected more often.

- 1 Remove and discard the hydraulic tank breather cap.
- 2 Install a new cap onto the tank.

# Maintenance

## Checklist D Procedures

### D-1

#### Check the Scissor Arm Wear Pads



DINGLI requires that this procedure be performed every 1000 hours or annually, whichever comes first.

Maintaining the condition of the scissor arm wear pads is essential to safe machine operation. Continued use of worn out wear pads may result in component damage and unsafe operating conditions.

Perform this procedure with the platform in the stowed position.

- 1 Measure the distance between the number one arm cross tube and the chassis deck at the ground controls side of the non-steer end of the machine.

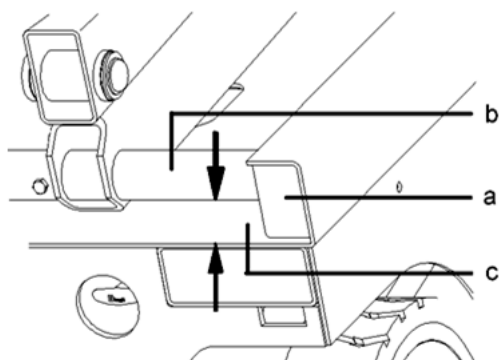

- a wear pad
- b arm cross tube
- c chassis deck

#### For JCPT0807HA/AC:

- ⊙ Result: The measurement is 23mm or more.  
Proceed to step 2.
- ⊗ Result: The measurement is less than 23 mm. Replace both wear pads.

#### For JCPT0808HA/AC~JCPT1612HAS/ACS:

- ⊙ Result: The measurement is 34mm or more.  
Proceed to step 2.
  - ⊗ Result: The measurement is less than 34 mm. Replace both wear pads.
- 2 Measure the distance between the number one arm cross tube and the chassis deck at the battery pack side of the non-steer end of the machine.

#### For JCPT0807HA/AC:

- ⊙ Result: The measurement is 23mm or more.  
Proceed to step 2.
- ⊗ Result: The measurement is less than 23 mm. Replace both wear pads.

#### For JCPT0808HA/AC~JCPT1612HAS/ACS:

- ⊙ Result: The measurement is 34mm or more.  
Proceed to step 2.
  - ⊗ Result: The measurement is less than 34 mm. Replace both wear pads.
- 3 Apply a thin layer of dry film lubricant to the area of the chassis where the scissor arm wear pads make contact.

**D-2****Replace the Hydraulic Tank Return Filter Element**

DINGLI requires that this procedure be performed every 1000 hours or annually, whichever comes first.

Replacement of the hydraulic tank return filter is essential for good machine performance and service life. A dirty or clogged filter may cause the machine to perform poorly and continued use may cause component damage. Extremely dirty conditions may require that the filter be replaced more often.

**⚠ CAUTION** Beware of hot oil. Contact with hot oil may cause severe burns.

**NOTICE** The hydraulic tank return filter is mounted on the bracket between the function manifold and the hydraulic power unit.

- 1 Clean the area around the oil filter.  
Remove the filter with an oil filter wrench.
- 2 Apply a thin layer of oil to the new oil filter gasket.
- 3 Install the new filter and tighten it securely by hand.
- 4 Use a permanent ink marker to write the date and number of hours from the hour meter onto the filter.
- 5 Turn the key switch to ground control. Pull out the platform and ground red Emergency Stop button to the on position.
- 6 Activate and hold the platform up toggle switch.
- 7 Inspect the filter and related components to be sure that there are no leaks.
- 8 Clean up any oil that may have spilled.

# Maintenance

## Checklist E Procedure

### E-1

#### Test or Replace the Hydraulic Oil



DINGLI requires that this procedure be performed every 2000 hours or every two years, whichever comes first.

Replacement or testing of the hydraulic oil is essential for good machine performance and service life. Dirty oil may cause the machine to perform poorly and continued use may cause component damage. Extremely dirty conditions may require oil changes to be performed more often.

Before replacing the hydraulic oil, the oil may be tested by an oil distributor for specific levels of contamination to verify that changing the oil is necessary.

If the hydraulic oil is not replaced at the two year inspection, test the oil quarterly. Replace the oil when it fails the test.

Note: Perform this procedure with the platform in the stowed position.

- 1 Disconnect the battery pack from the machine.

**⚠ WARNING** Electrocutation / burn hazard: Contact with electrically charged circuits could result in death or serious injury. Remove all rings, watches and other jewelry.

- 2 Open the power unit module tray.
- 3 Remove the oil drain plug at bottom.
- 4 Drain all of the oil into a suitable container.
- 5 Tag and disconnect the hydraulic tank return line from the hydraulic filter head and remove the line from the tank. Cap the fitting on the filter head.

- 6 Tag and disconnect the hydraulic pump inlet line and remove the line from the tank. Cap the fitting on the pump.
- 7 Remove the hydraulic tank retaining fasteners and remove the hydraulic tank from the machine.

**⚠ WARNING** Bodily injury hazard.

Spraying hydraulic oil can penetrate and burn skin. Loosen hydraulic connections very slowly to allow the oil pressure to dissipate gradually. Do not allow oil to squirt or spray.

- 8 Clean up any oil that may have spilled. Properly discard the used oil.
- 9 Clean the inside of the hydraulic tank using a mild solvent. Allow the tank to dry completely.
- 10 Install a new filter onto the tank.
- 11 Tighten the drain plug. Torque to specification.

---

#### Torque specifications

Hydraulic tank drain plug, dry	4.5Nm
Hydraulic tank drain plug, lubricated	3.4Nm
<hr/>	
12 Install the hydraulic tank and install and tighten the hydraulic tank retaining fasteners. Torque to specification.	
<hr/>	
<b>Torque specifications</b>	
Hydraulic tank retaining fasteners, dry	4Nm
Hydraulic tank drain plug, lubricated	2.9Nm

---

## Maintenance

- 13 Install the hydraulic pump inlet line into the tank. Install the fitting onto the pump and torque.
- 14 Install the hydraulic pump return line into the tank. Install the fitting onto the hydraulic filter head and torque.
- 15 Fill the tank with hydraulic oil until the fluid is full in the hydraulic tank. Do not overfill.
- 16 Activate the pump to fill the hydraulic system with oil and bleed the system of air.

 **WARNING** Component damage hazard.  
The pump can be damaged if operated without oil. Be careful not to empty the hydraulic tank while in the process of filling the hydraulic system. Do not allow the pump to cavitate.

# Schematic

## Hydraulic Schematic

JCPT0807HA

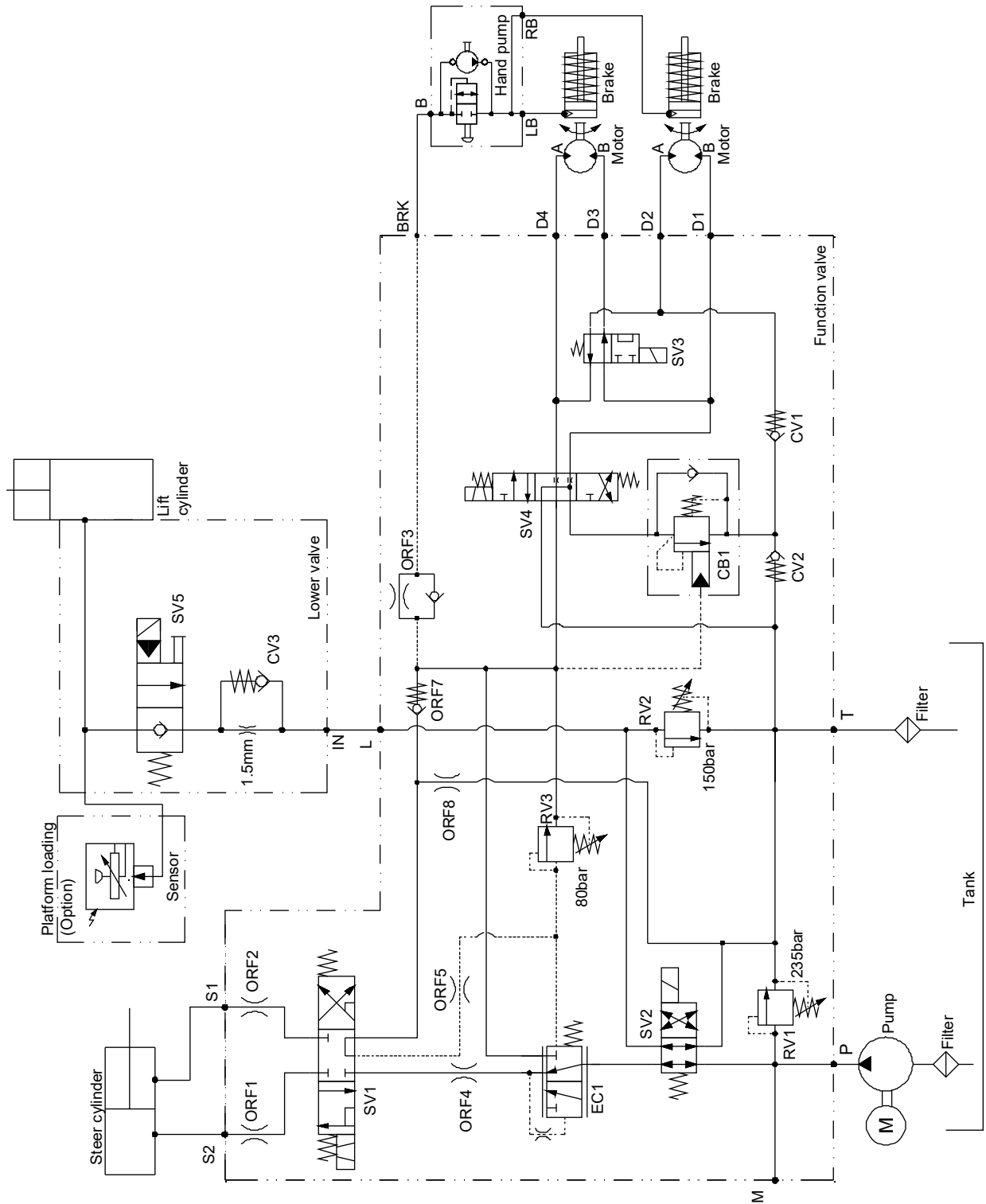

# Schematic

## Hydraulic Schematic

JCPT0808HA JCPT0812HA JCPT1008HA JCPT1012HA

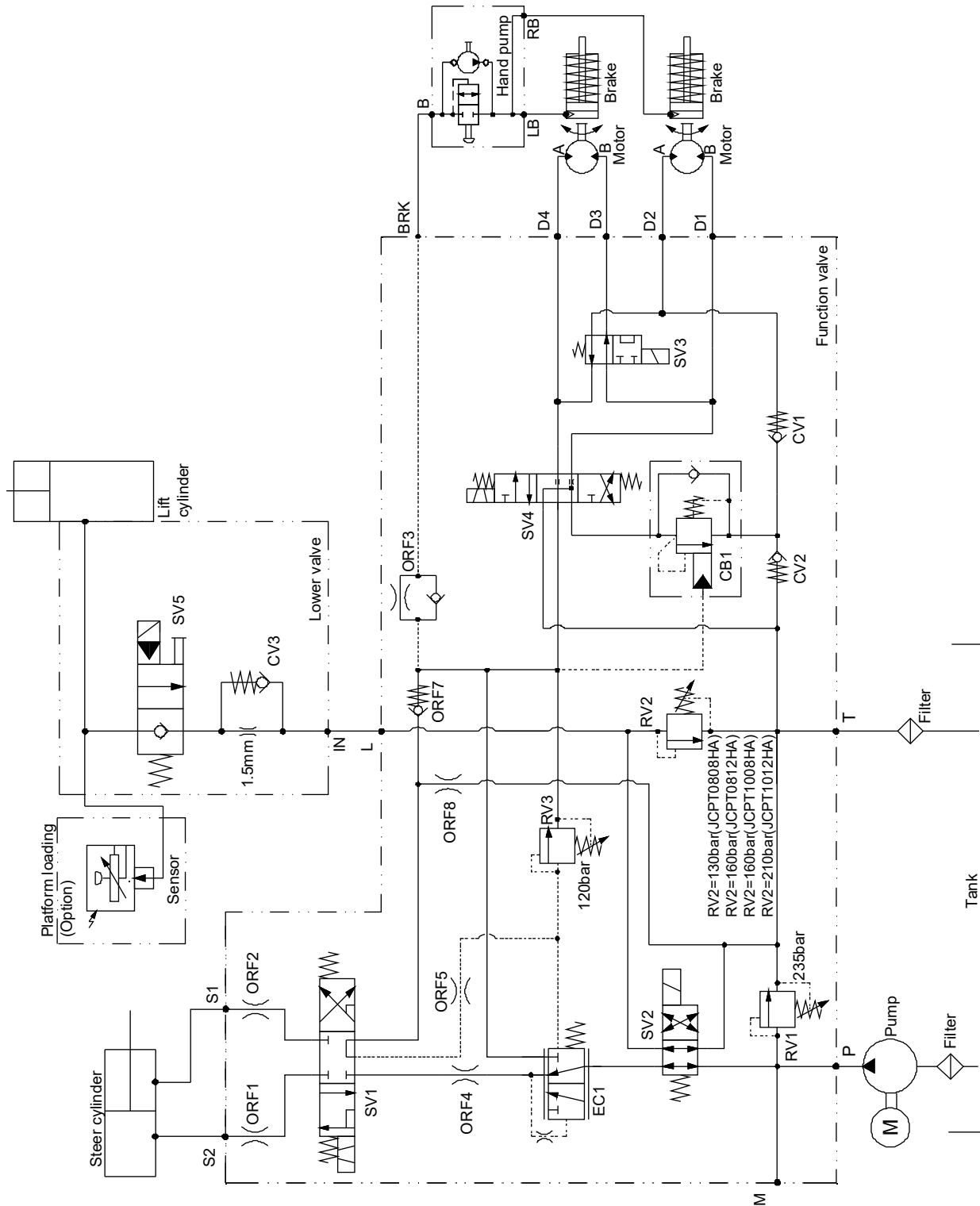



# Schematic

## Hydraulic Schematic

JCPT1212HA JCPT1412HA JCPT1612HA JCPT1612HAS

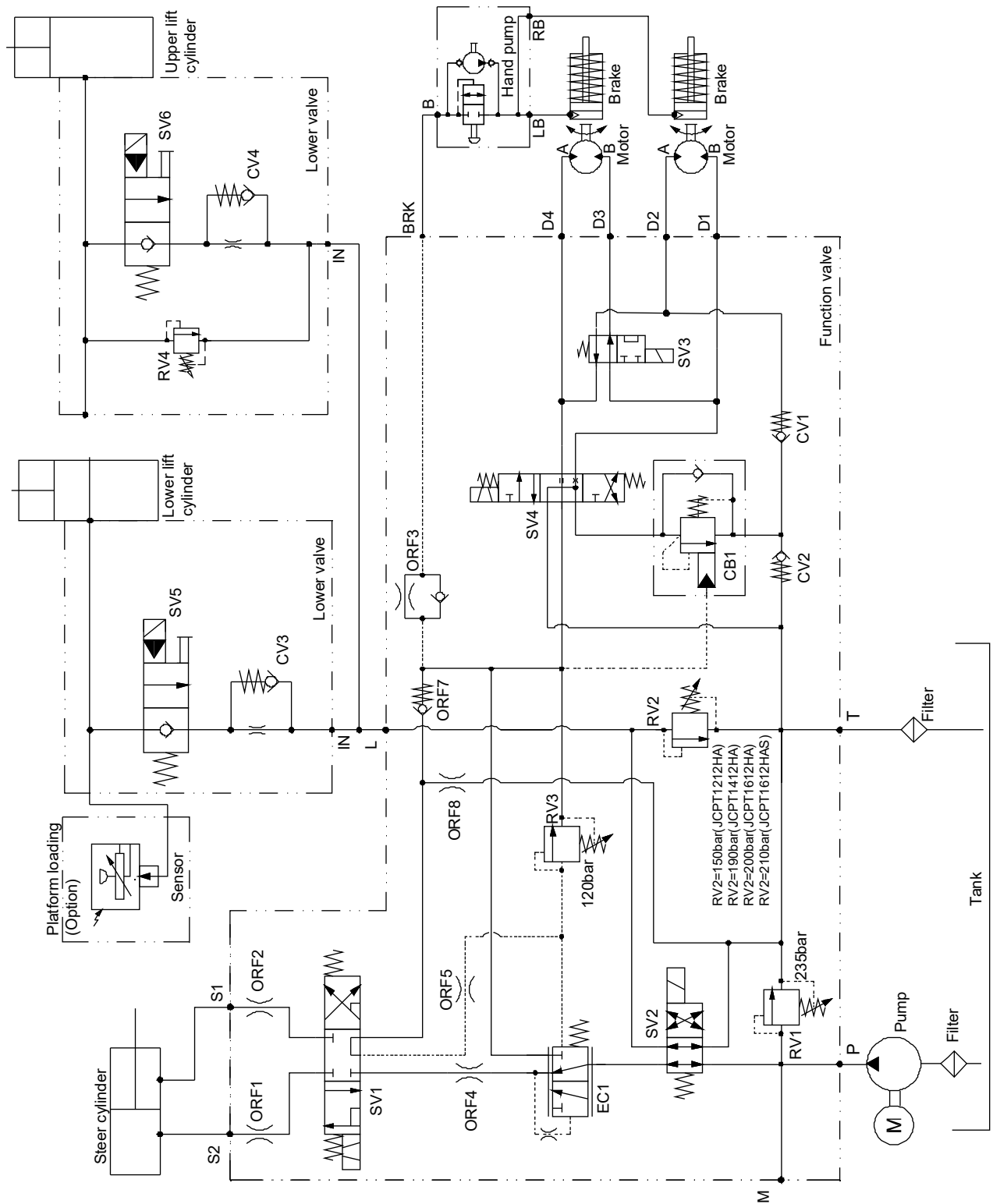

# Schematic

## Hydraulic Schematic

JCPT0807AC

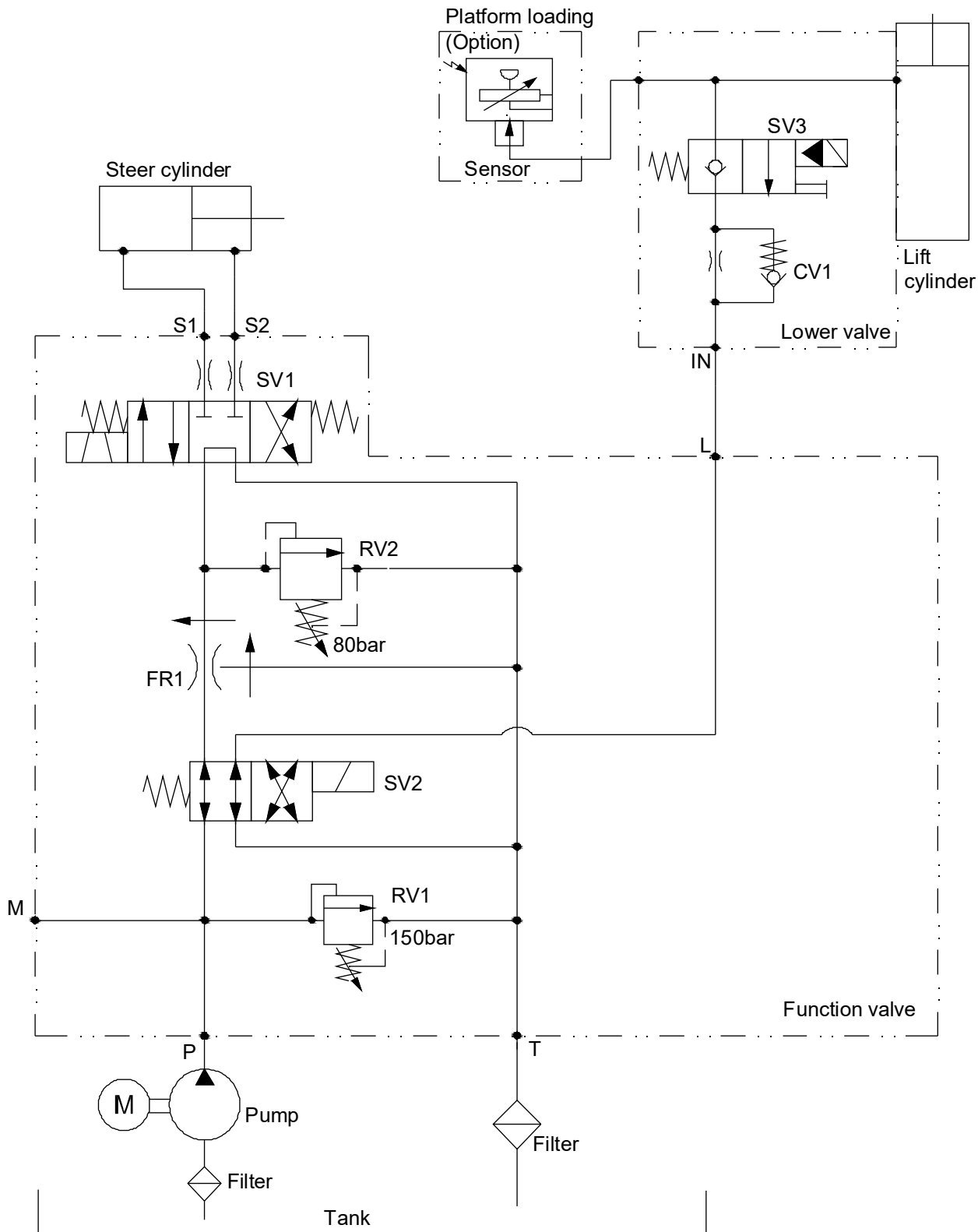

# Schematic

## Hydraulic Schematic

JCPT0808AC JCPT0812AC JCPT1008AC JCPT1012AC

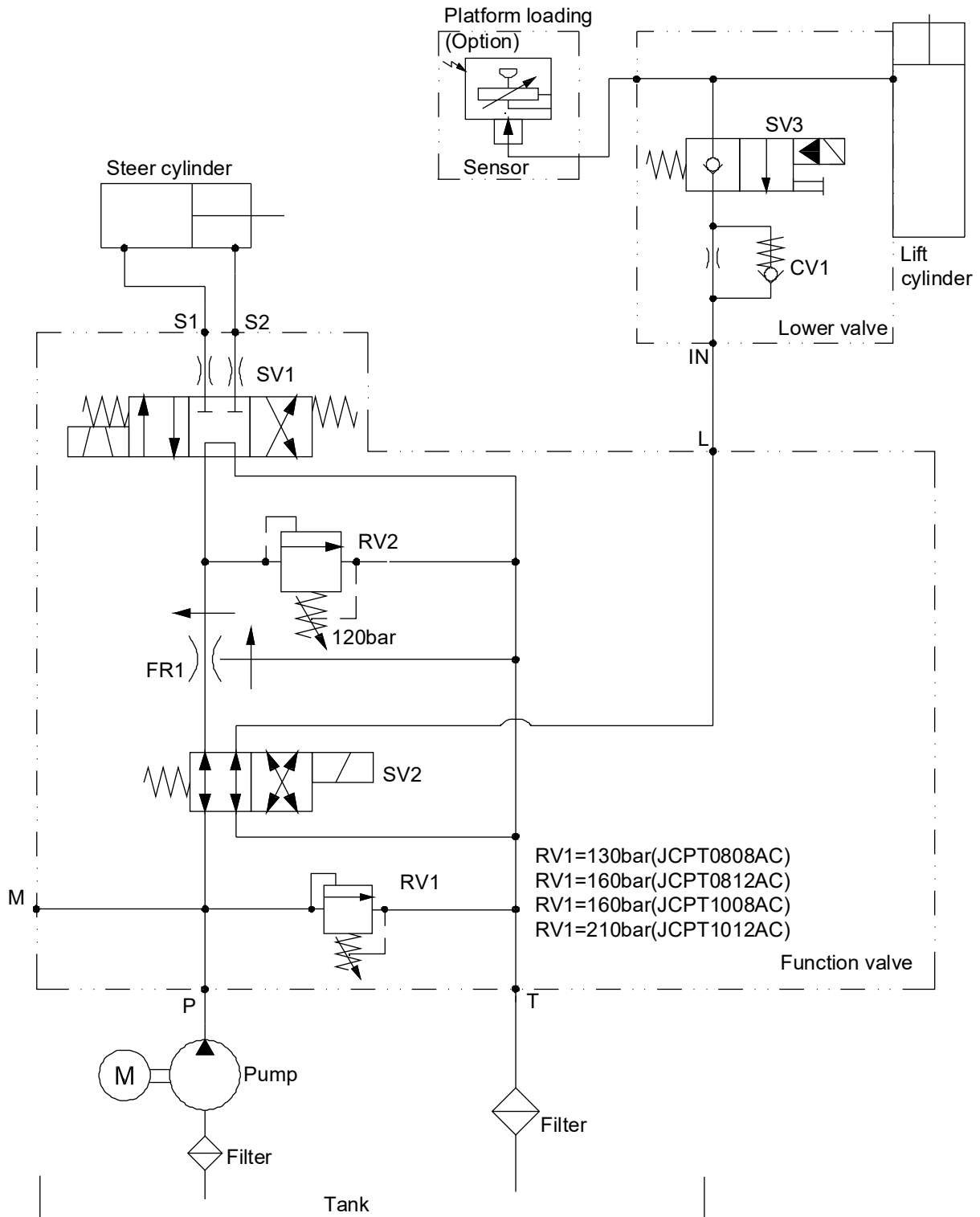

# Schematic

## Hydraulic Schematic

JCPT1212AC JCPT1412AC JCPT1612AC JCPT1612ACS

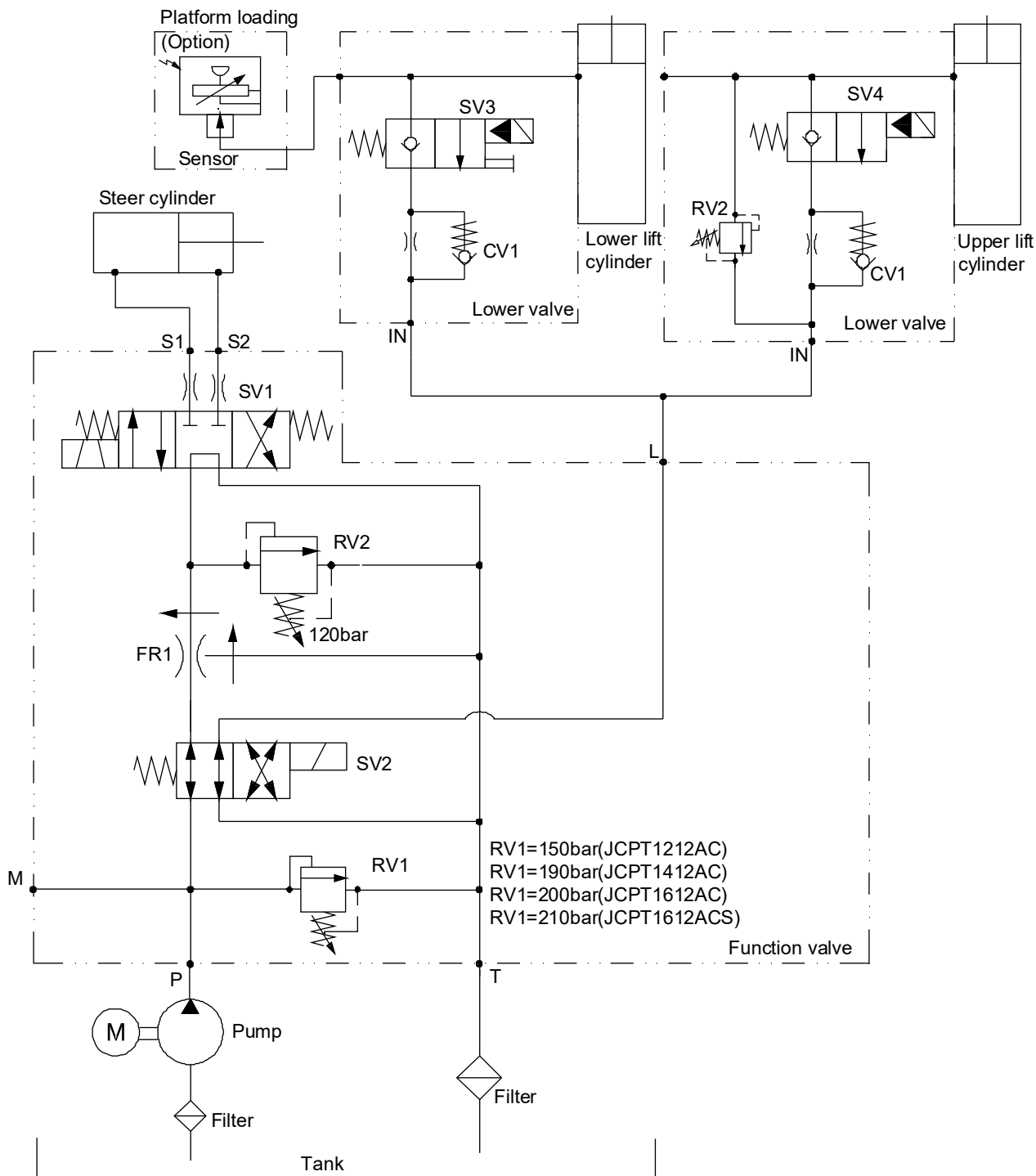

# Schematic

## Electrical Schematic

### JCPT0807HA (Lead-acid battery)

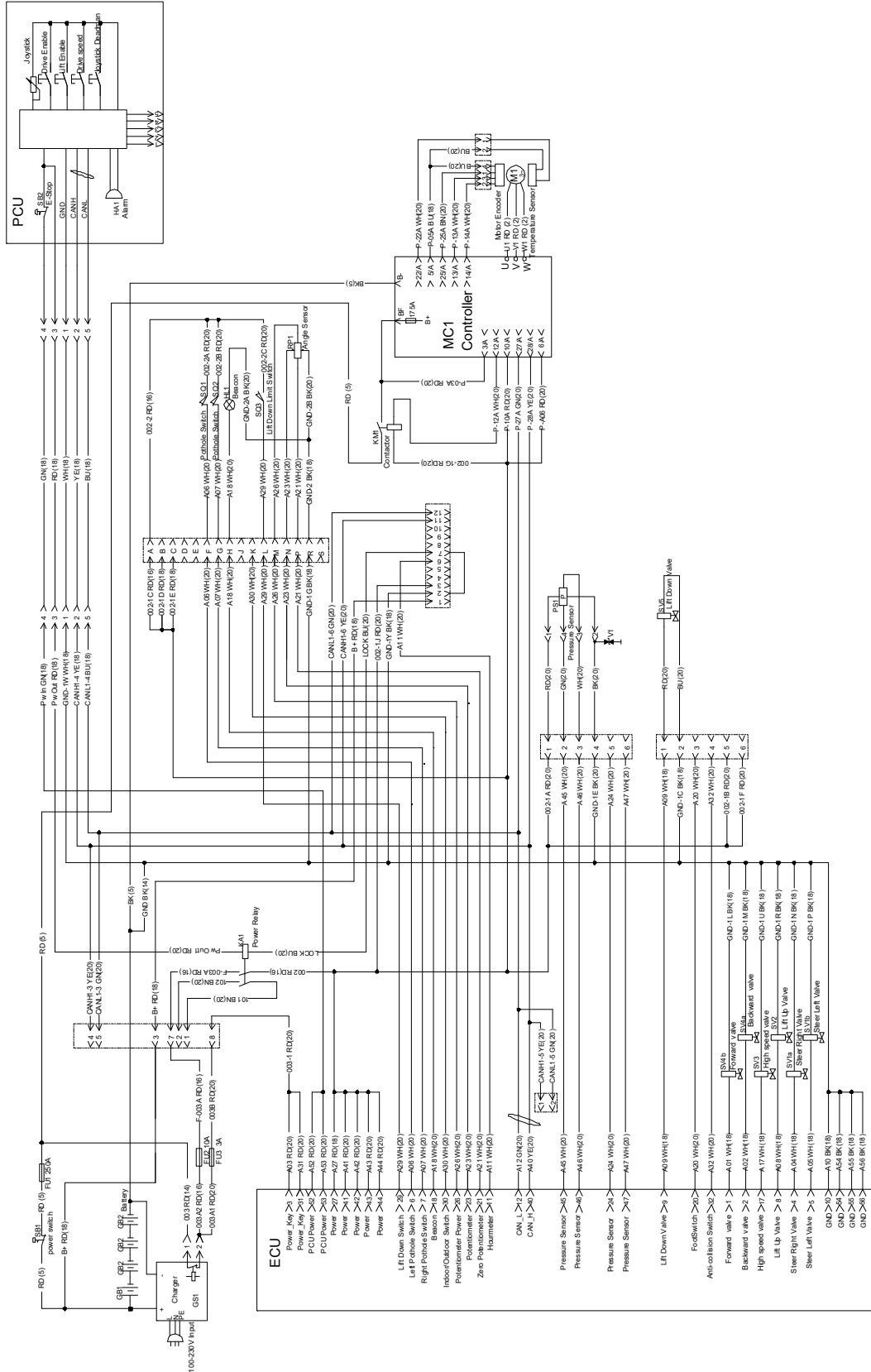

# Electrical Schematic

## JCPT0808HA~JCPT1612HA (Lead-acid battery)

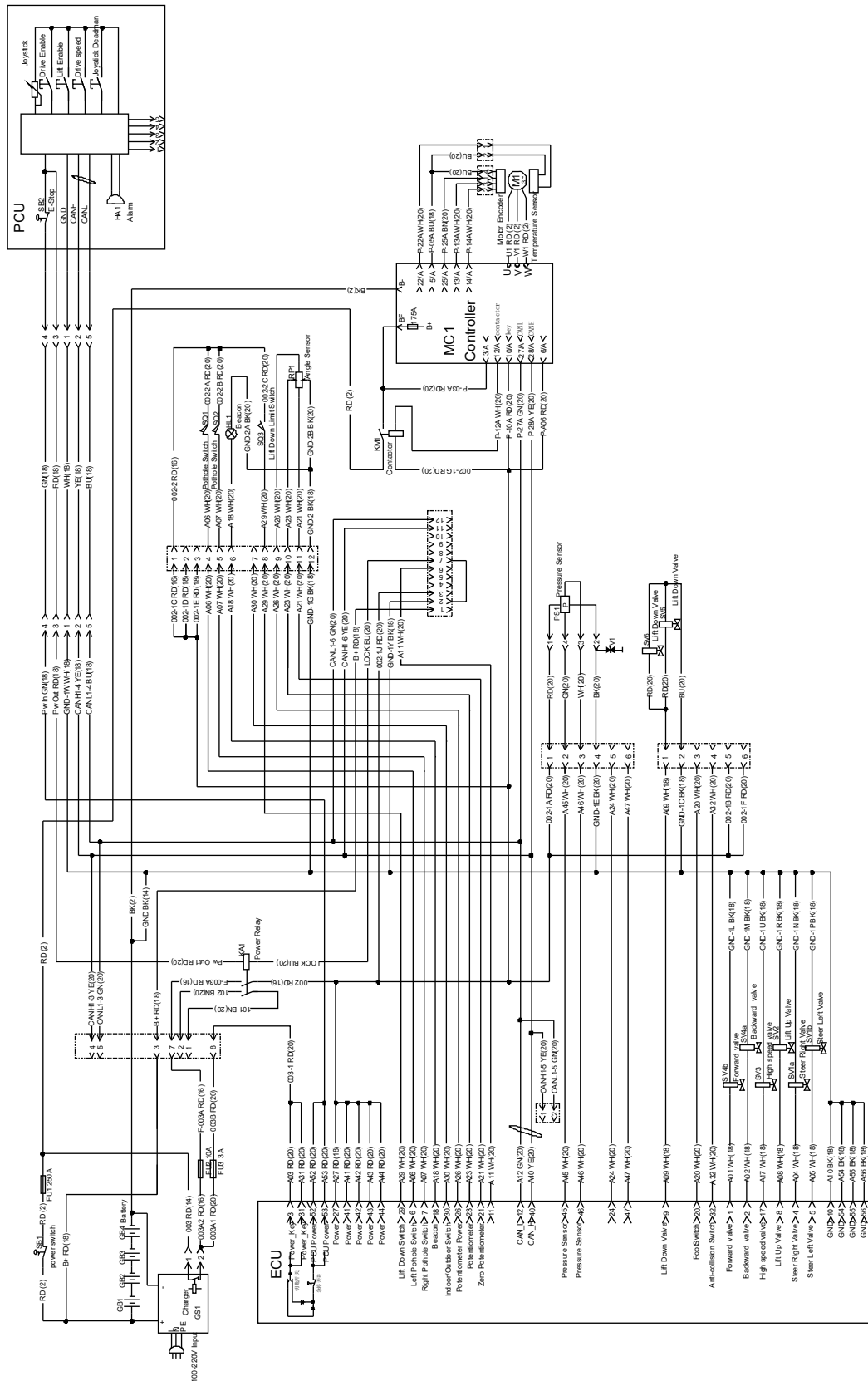

# Schematic

## Electrical Schematic

### JCPT0807HA (Lithium battery)

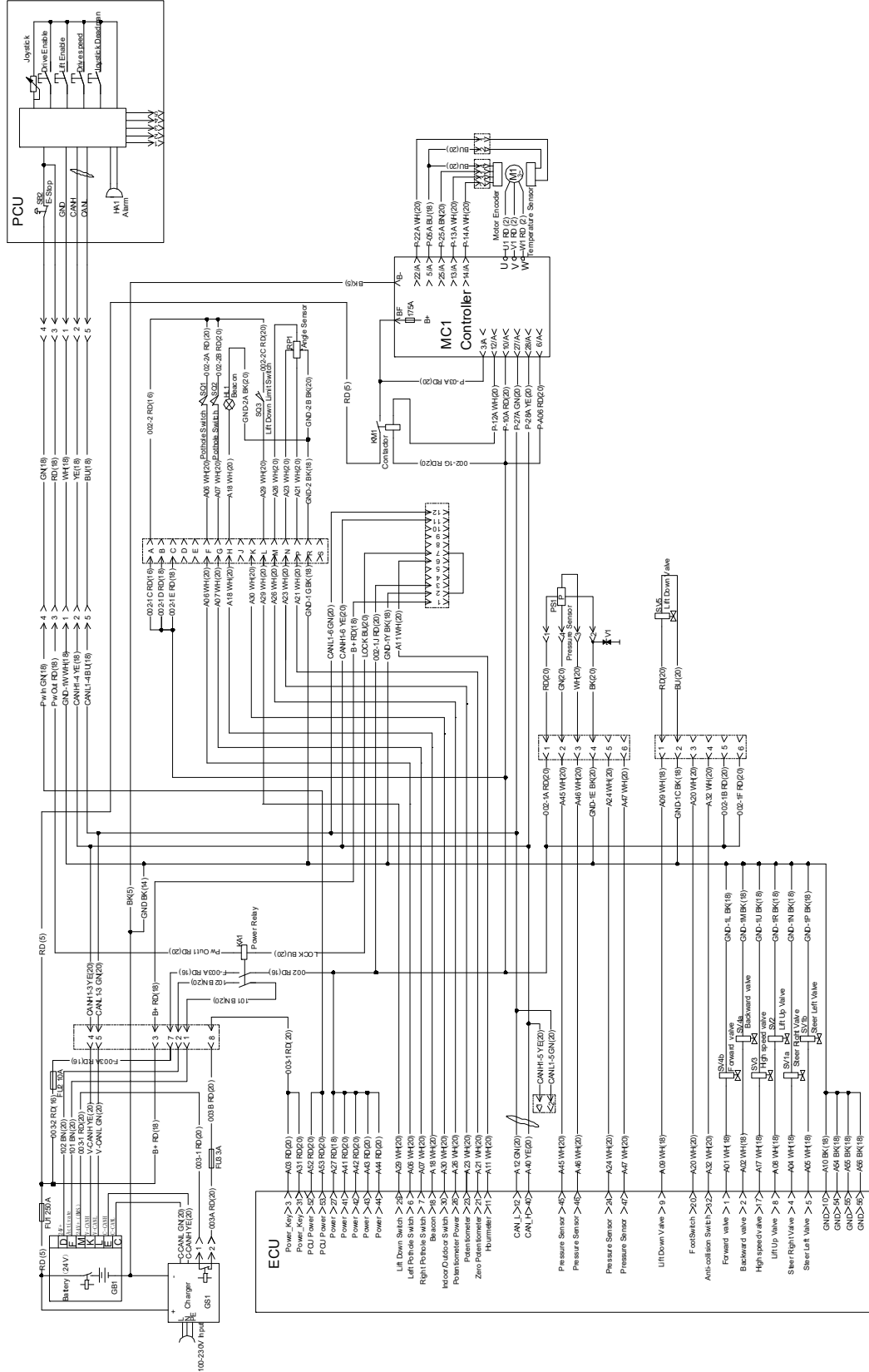

# Electrical Schematic

## JCPT0808HA~JCPT1612HAS (Lithium battery)

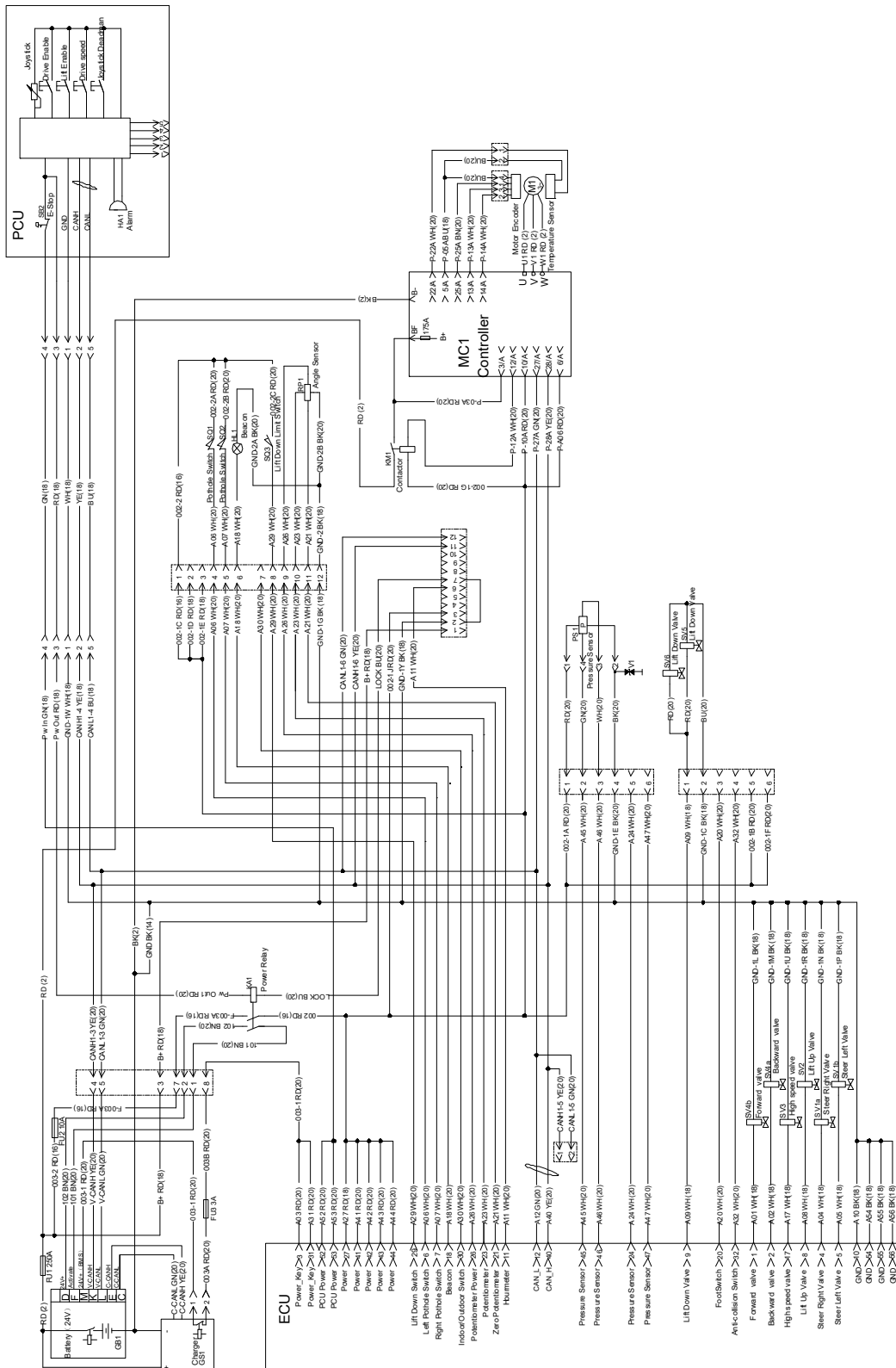



# Schematic

## Electrical Schematic

### JCPT0807AC (Lead-acid battery)

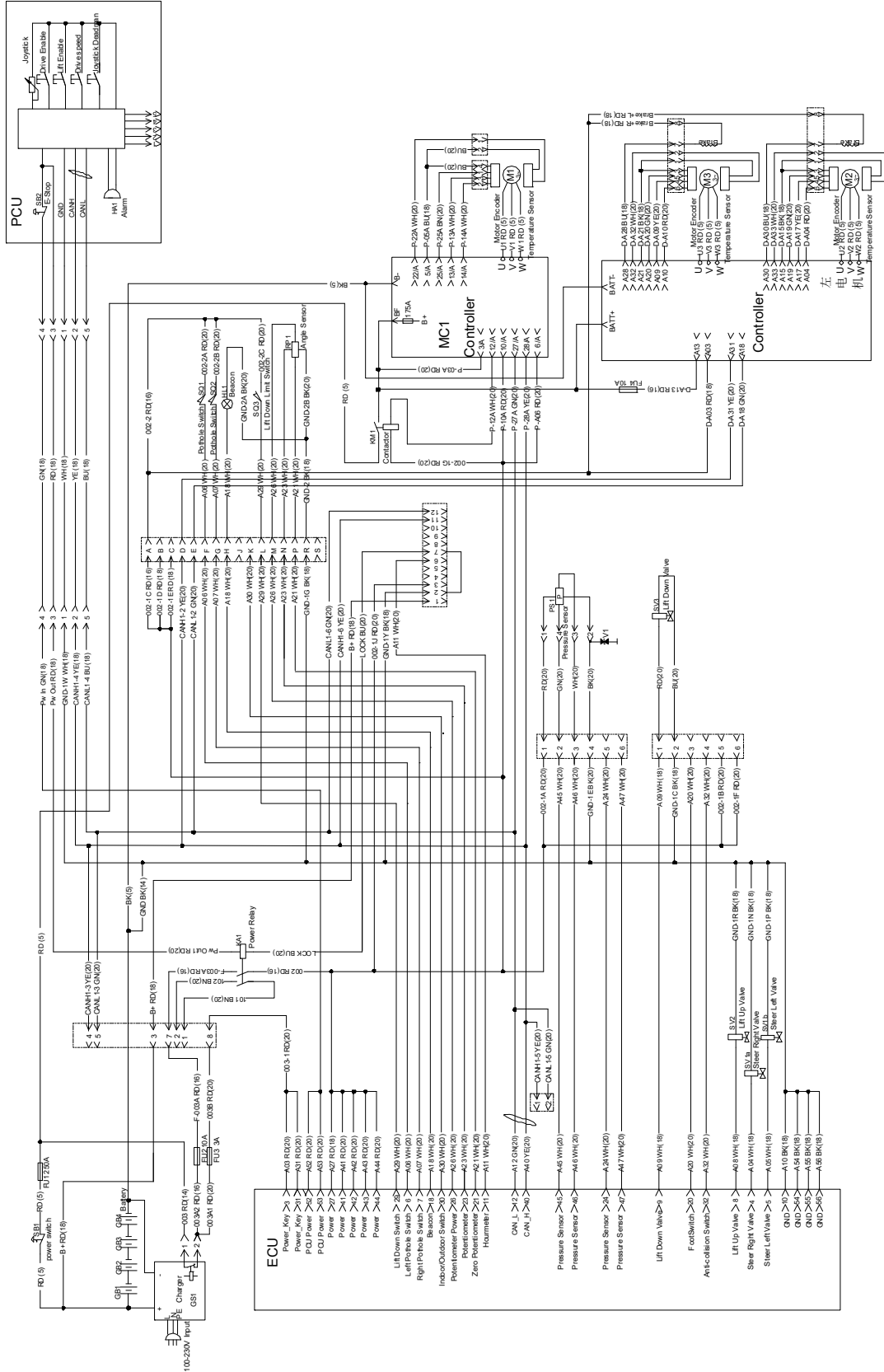

# Electrical Schematic

## JCPT0808AC~JCPT1612ACS (Lead-acid battery)

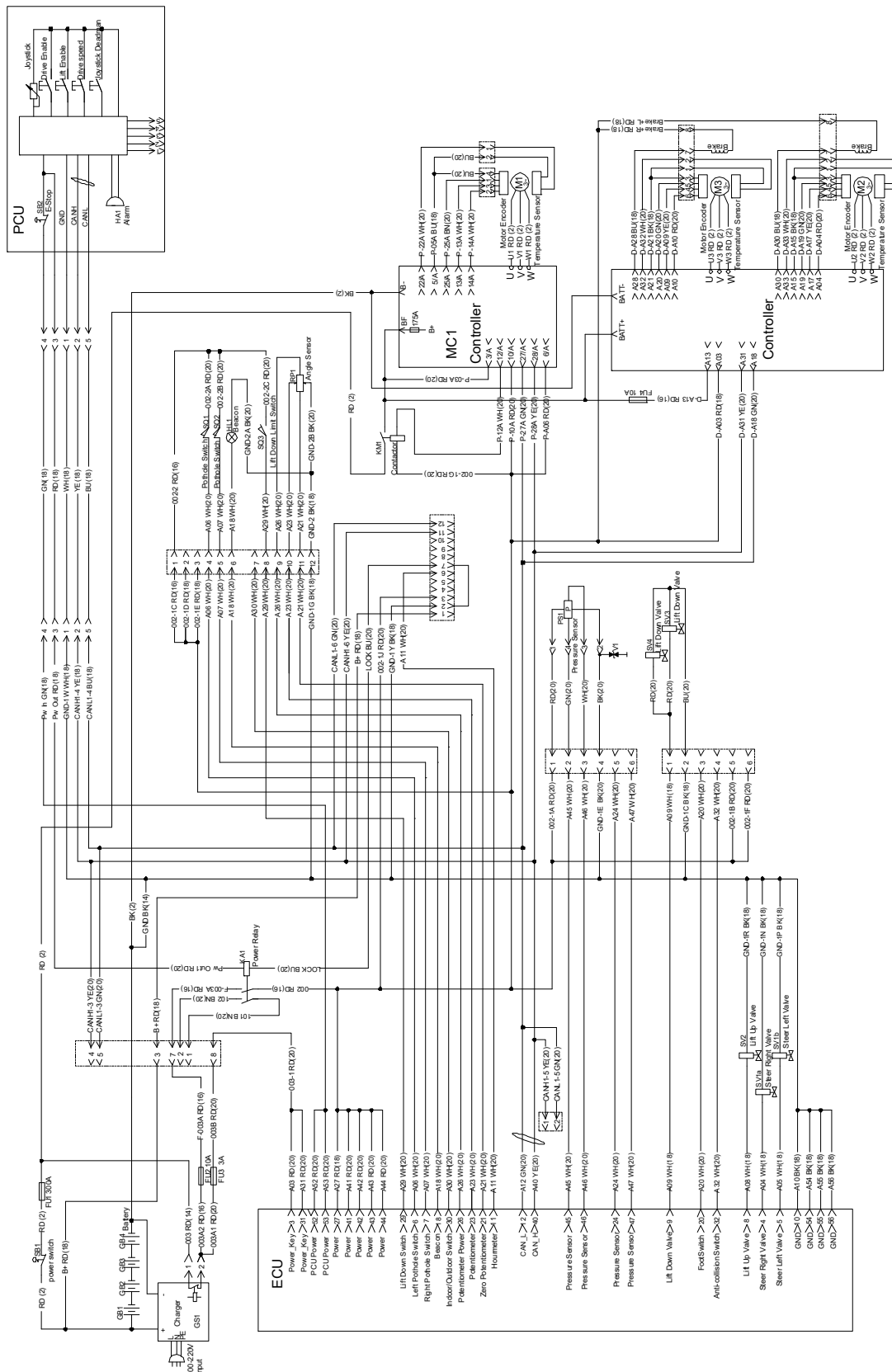

# Schematic

## Electrical Schematic

### JCPT0807AC (Lithium battery)

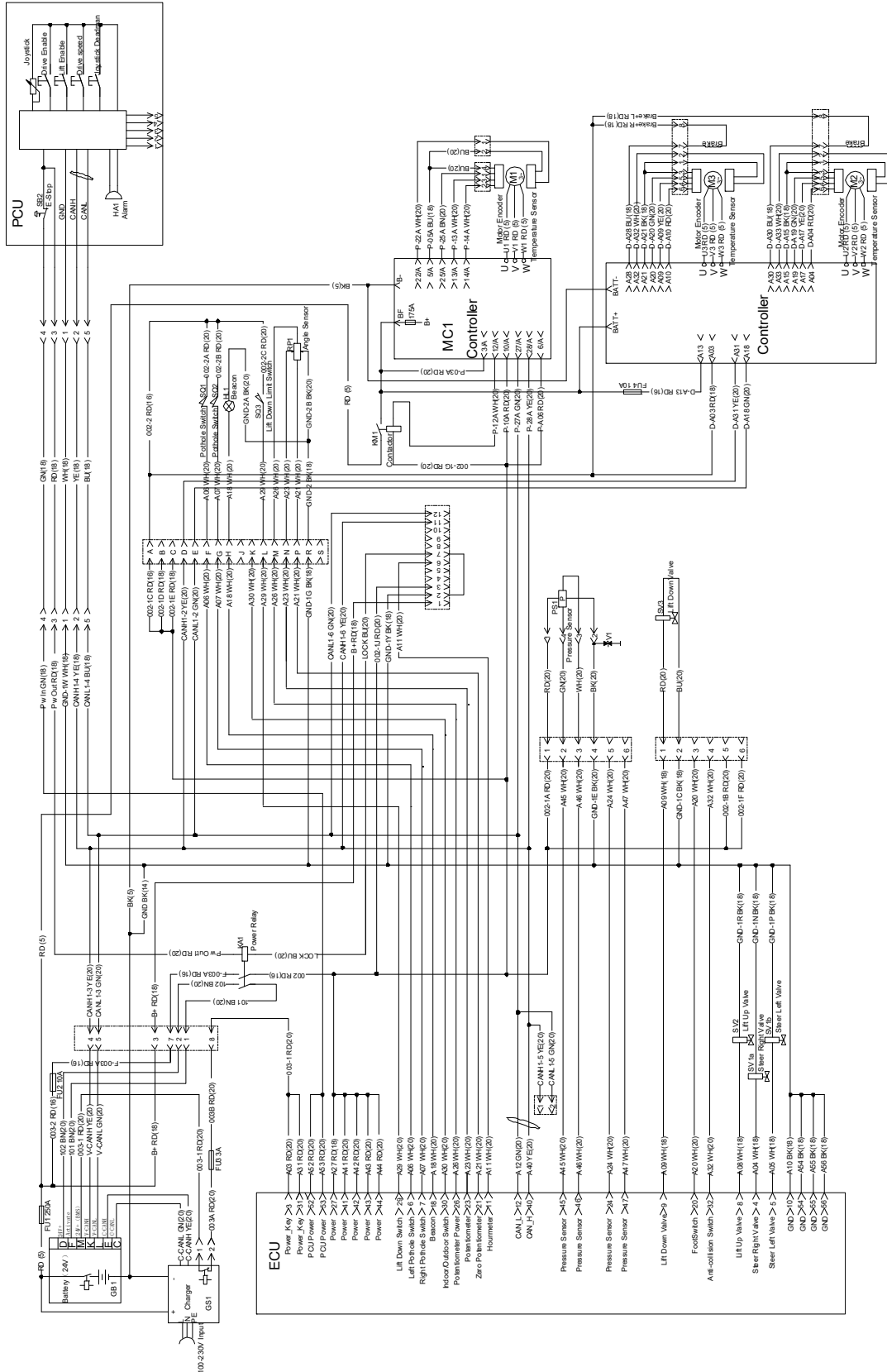

# Electrical Schematic

## JCPT0808AC~JCPT1612ACS (Lithium battery)

