

exact

EN Operating Instructions

PipeCut+Bevel 280 Pro Series 360 Pro Series 460 Pro Series

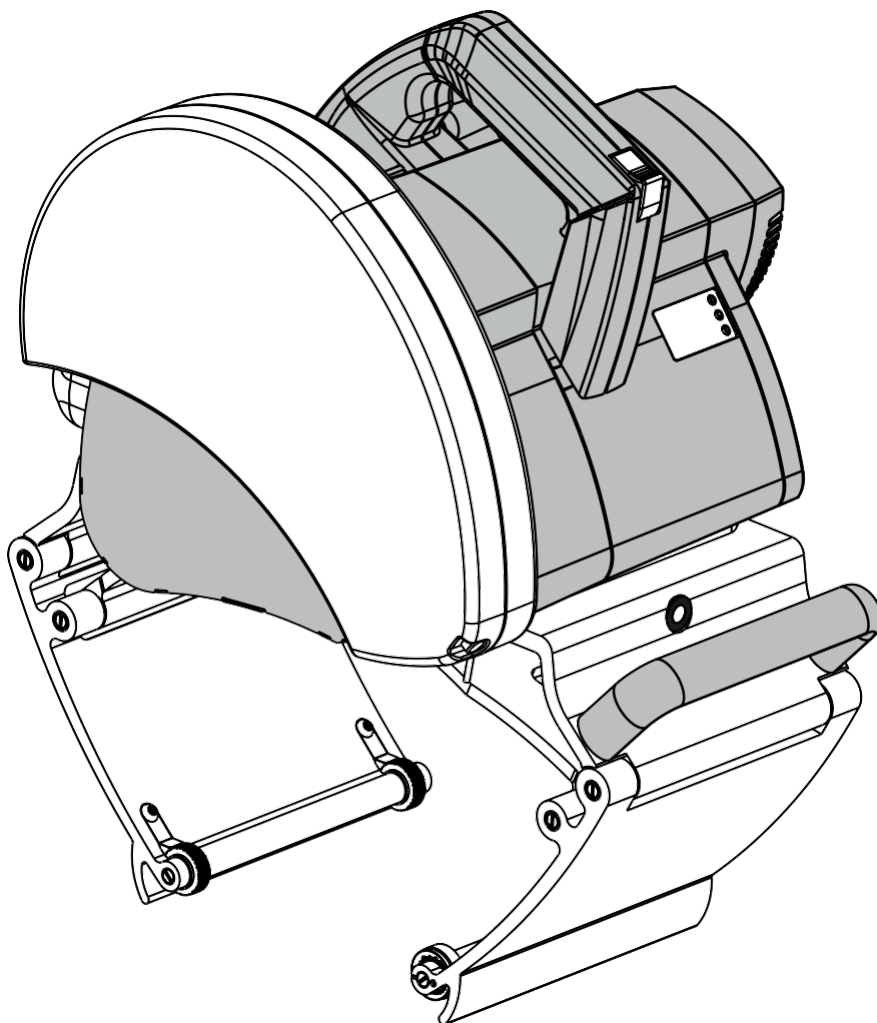

These instructions are translation of the original instructions written in Finnish language.
All instructions are available on web-site: exacttools.com/manuals

exact Patents: US 7,257,895, JP 4010941, EP 1301311, FI 108927, KR 10-0634113

Exact PipeCut+Bevel 280 / 360 / 460 Pro Series

Data of Exact PipeCut saw blades

1. Exact TCT saw blades are for cutting steel, copper, aluminum and all kind of plastics pipe materials. Exact TCT saw blades can be sharpened.
2. Exact CERMET saw blades are for cutting stainless steel, acid proof materials, steel, copper, aluminum and all kind of plastic pipe materials. Exact CERMET saw blades can be sharpened.
3. Exact CERMET ALU saw blades are for cutting all kind of aluminum and plastic pipe materials. Exact CERMET ALU saw blades can be sharpened.
4. Exact TCT P blades are for cutting all kind of plastic pipe materials. Exact TCT P saw blades can be sharpened.
5. Exact DIAMOND X discs are for cutting Cast or Ductile Iron only. Exact DIAMOND X discs cannot be sharpened.

280 Pro Series / 360 Pro Series / 460 Pro Series speed control recommendations:

Stainless steel	I
Steel	II
Cast-iron	II
Plastics	II

Declaration of Conformity (CE)

We declare under our sole responsibility that the pipe cutting machines Exact PipeCut+Bevel 280 / 360 / 460 Pro Series Described under "Technical Data" are in conformity with the following standards or standardization documents:

IEC 62841-1:2014, IEC 62841-2-5:2014, EN 62841-1:2015, EN 62841-2-5:2014, EN 55014-1, EN 55014-2, EN 61000-3-2, EN 61000-3-3

These instructions are translation of the original instructions written in Finnish

For more information, please contact Exact Tools at the following address:

The technical file is available at the address underneath:

The person authorized to compile the technical file:

Seppo Makkonen, chairman of the board (seppo.makkonen@exacttools.com)

Helsinki, 01.02.2018



Seppo Makkonen, chairman of the board Exact Tools Oy
Särkiniementie 5 B 64
FI-00210 Helsinki, Finland

FIGURE A

- 1 Unlocking switch
- 2 Power switch
- 3 Power switch locking lever (in front of the switch)
- 4 Blade guard cover
- 5 Overload indicator light
- 6 Moving blade-guard
- 7 Adjusting screws
- 8 Laser pointer box
- 9 Adjusting wheel
- 10 Handle
- 11 Blade guard screw
- 12 Lock pin
- 13 Plate
- 14 Motor unit
- 15 Blade RPM speed control
- 16 Adjustment arrow
- 17 Adjustment slot
- 18 Gripping device adjusting knob
- 19 Gripping device locking collar
- 20 Gripping device
- 21 Laser pointer batteries (inside the blade protection)
- 22 Battery seat cover (inside the blade protection)
- 23 Laser Pointer (inside the blade protection)
- 24 Handle to carry the saw
- 25 Laser switch

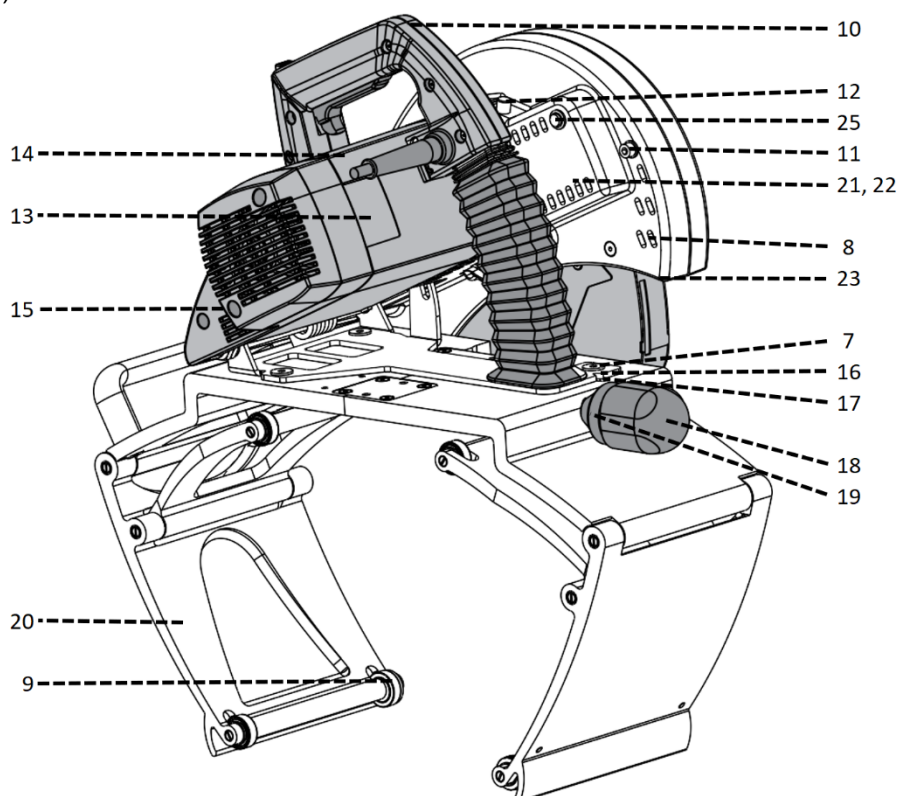
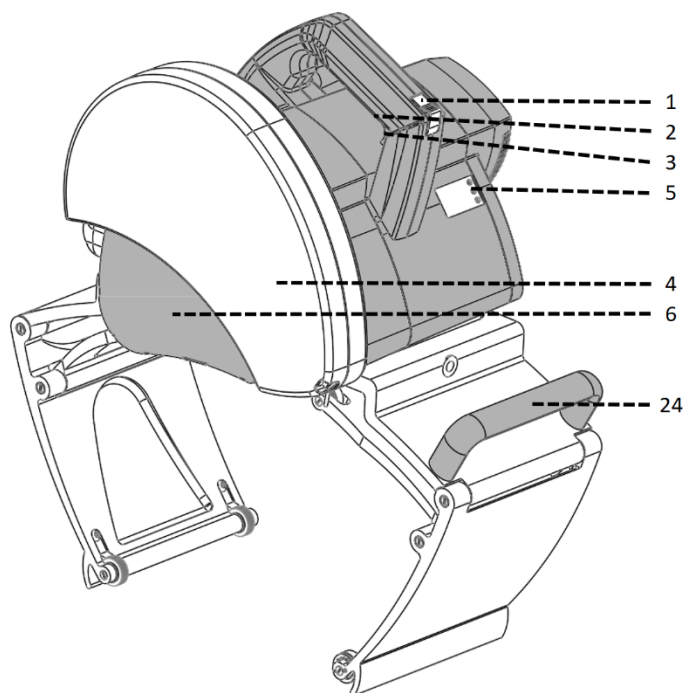
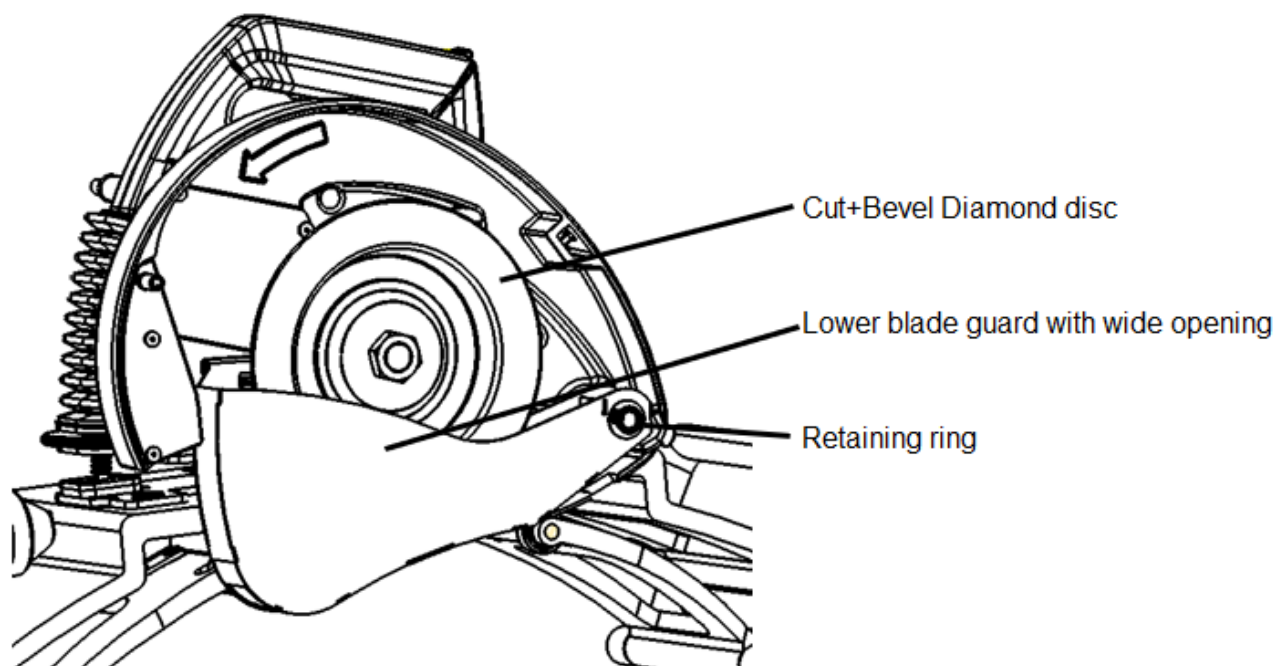
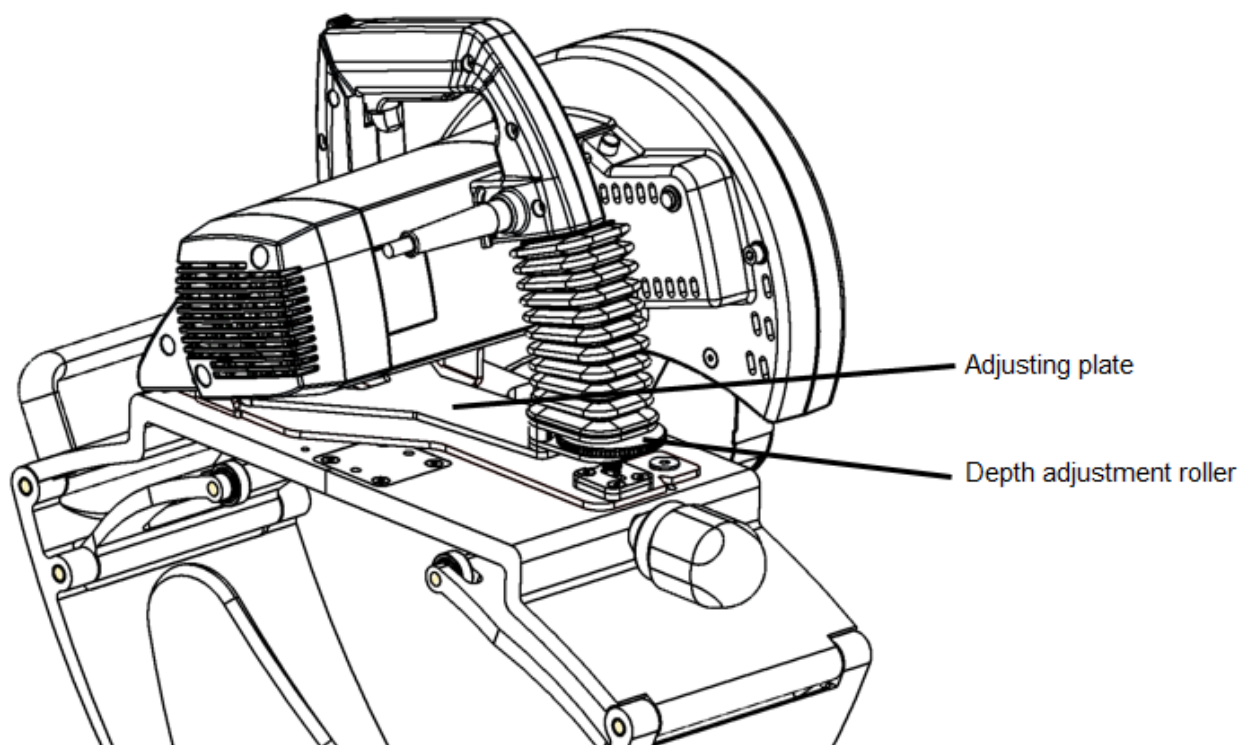

FIGURE A2



Contents**Information**

Technical data	6
Package contents	7

Safety

Safety instructions	8
---------------------	---

Operation

Functional description	11
Product features	12
Before operating the tool	13
Connection to mains power supply	13
Setting the pipe on supports	13
Attaching the pipe saw to the pipe	13
Piercing the pipe wall	14
Cutting around the pipe	14
Overload protection and RPM adjustment	15
Explanation if indicator lights	15
Improving possible misalignment of the cut	15
Cutting result adjustment on Exact	16
PipeCut+Bevel 280 / 360 / 460 Pro Series	
Installing and changing the blade	17
Maintenance and servicing instructions	17
Environment / disposal	18
Guarantee / guarantee conditions	18
Tips for using Exact PipeCut saws	18
Extra equipment	19
Theoretical cutting depths	19

Exact PipeCut+Bevel 280 / 360 / 460 Pro Series

Voltage	230 V– 240 V / 50–60 Hz / 100 V–120 V 50–60Hz
Power	2500 W– 230 V– 240 V / 15 A-100 V– 120 V
No-load speed	I (low) = 1900/min, II (high) = 2885 /min
Blade diameter	140 mm (5.6"), 165 mm (6.50"), 180 mm (7.2"), 190 mm (7.6")
Mounting bore	62 mm (2.44")
Weight	PipeCut+Bevel 280 Pro Series 16 kg (35 lbs), PipeCut+Bevel 360 Pro Series 17,5 kg (40 lbs), PipeCut+Bevel 460 Pro Series 18,5 kg (42 lbs)
Range of use PipeCut+Bevel 280 Pro Series	40 mm–280 mm (1.6"–11")
Range of use PipeCut+Bevel 360 Pro Series	75 mm–360 mm (3.0"–16")
Range of use PipeCut+Bevel 460 Pro Series	100 mm–460 mm (4"–17.5")
Max. pipe wall, plastics and other soft materials	45 mm (1.8") 280 50 mm (2.0") 360 and 460
Max. Pipe wall 230V, steel, iron	20 mm / 0.78"
Max. Pipe wall 120V, steel, iron	12 mm / 0.47"
Protection class	▣ / II
Spindle lock	Yes
Speed preselection	Yes
Constant electronic control	Yes
Overload Protection	Yes
Reduced starting current	Yes
Vibration, A _{h,M} "cutting metal"	3,2 m/s ²
Vibration uncertainty, K	0,3 m/s ²
LpA (sound pressure)	101,0 dB(A)
KpA (sound pressure uncertainty)	3 dB(A)
LWA (acoustic power)	112,0 dB(A)
KWA (acoustic power uncertainty)	3 dB(A)
Recommended generator capacity	4,9kVA for 230V, 3kVA for 100 V-120V

The values given are valid for nominal voltages [U] of 230/240 V. For lower voltage and models for specific countries, these values can vary.

Exact PipeCut+Bevel 280 / 360 / 460 Pro Series pipe cutting systems

Package contents, please check that the package contains the following items:

1. Exact PipeCut System Shoulder Bag
2. Exact PipeCut+Bevel 280 / 360 / 460 Pro Series pipe saw
3. Pipe Cutting supports 1 + 2 pcs. (280 4pcs aluminum)
4. Operating instructions
5. Allen key 2 pcs (5 mm and 2 mm) and blade adjusting key.
6. Exact Cut+Bevel Diamond disc 165
7. Lower blade guard with wide opening for Cut+Bevel Diamond disc

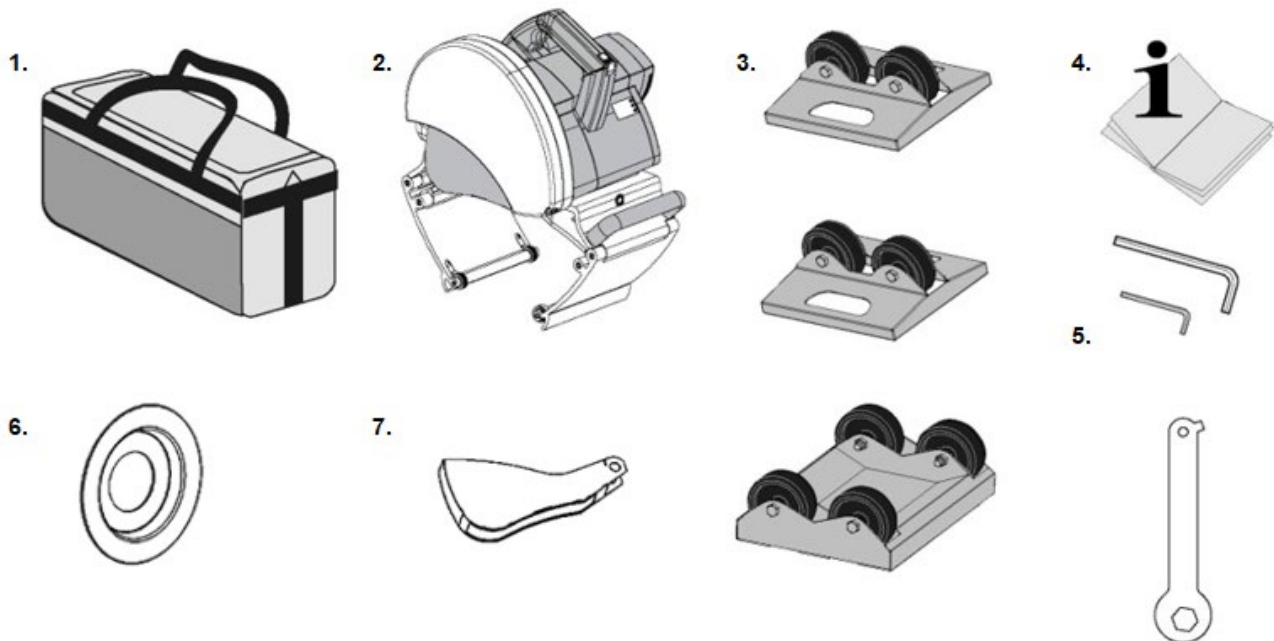



Definitions: Safety instructions

The definitions below describe the level of severity for each signal word. Please read the manual and pay attention to these symbols

 **DANGER:** Indicates an imminently hazardous situation which, if not avoided, will result in serious injury or in extreme cases a fatality

 **WARNING:** Indicates a potentially hazardous situation which, if not avoided, could result in serious injury or in extreme cases a fatality

 **CAUTION:** Indicates a potentially hazardous situation which, if not avoided, may result in minor or moderate injury.

 **NOTICE:** Indicates a practice not related to personal injury which, if not avoided, may result in property damage.

 **Denotes risk of electric shock.**

Symbols found on the machine.

 **Use ear protection.**

 **Use gloves.**

 **Read instructions before use.**

 **Laser radiation:** Do not look directly into beam.



Saw blade: Saw blade behind this cover, do not insert fingers or other body parts inside this cover.

Operating, safety and service instructions

Read these operating, safety and service instructions carefully before operating the pipe saw.

Store these instructions in a place where all pipe saw operators have access. In addition to these instructions official work, health and safety rules must be followed. Exact PipeCut is for professional use only.

Please notice the article number on the type plate of your machine. The trade names of the individual machines may vary.

Only for power tools without reduced starting current: Starting cycles generate brief voltage drops. Interference with other equipment/machines may occur in case of unfavorable mains system conditions. Malfunctions are not to be expected for system impedances below 0.36 ohm.

Noise/vibration Information

The vibration emission level given in this information sheet has been measured in accordance with a standardized test given in EN62481-2-5:2014

Use ear protection!

Vibration level values (sum of vectors of three directions) are defined in accordance with standard EN62841-2-5:2014:

Vibration rate $a_{h,M}$ "cutting metal" = 3.2 m/s²,
Uncertainty K = 0,3 m/s².

The vibration emission level given in this information sheet has been measured in accordance with a standardized test given in EN62841-2-5:2014 and may be used to compare one tool with another. It may be used for a preliminary assessment of exposure.

 **WARNING:** The declared vibration emission level represents the level during main applications of the tool.

However, if the tool is used for different applications, with different accessories or poorly maintained, the vibration emission may differ. This may significantly increase the exposure level over the total working period.

An estimation of the level of exposure to vibration should also take into account the times when the tool is switched off or when it is running but not actually doing the job. This may significantly reduce the exposure level over the total working period.

Identify additional safety measures to protect the operator from the effects of vibration such as: maintain the tool and the accessories, keep the hands warm, organize work patterns.

 **WARNING:**

If Exact PipeCut+Bevel 280 / 360 / 460 Pro Series tool is used with generator or extension cords, their minimum requirements are as follows:

Generator: minimum power of 3500 watts, if other electrical equipment is not used at the same time.

Extension cords 230 V: The maximum length - 25 meters. Cable cross section - not less than 2,5mm².

Extension cords 120 V: The maximum length – 82 Feet Extra Heavy Duty

General power tool safety warnings



WARNING: Read all safety warnings, illustrations and specifications provided with this power tool. Failure to follow all instructions listed below may result in electric shock, fire and/or serious injury

Save all warnings and instructions for future reference.

The term “power tool” in the warnings refers to your mains operated (corded) power tool or battery-operated (cordless) power tool.

1 Work area safety

- a) **Keep work area clean and well lit.** Cluttered or dark areas invite accidents.
- b) **Do not operate power tools in explosive atmospheres, such as in the presence of flammable liquids, gases or dust.** Power tools create sparks which may ignite the dust or fumes.
- c) **Keep children and bystanders away while operating a power tool.** Distractions can cause you to lose control.

2 Electrical safety

- a) **Power tool plugs must match the outlet. Never modify the plug in any way. Do not use any adapter plugs with earthed (grounded) power tools.** Unmodified plugs and matching outlets will reduce risk of electric shock.
- b) **Avoid body contact with earthed or grounded surfaces, such as pipes, radiators, ranges and refrigerators.** There is an increased risk of electric shock if your body is earthed or grounded.
- c) **Do not expose power tools to rain or wet conditions.** Water entering a power tool will increase the risk of electric shock
- d) **Do not abuse the cord. Never use the cord for carrying, pulling or unplugging the power tool. Keep cord away from heat, oil, sharp edges or moving parts.** Damaged or entangled cords increase the risk of electric shock
- e) **Damaged cable should be changed in the authorized service center.**
- f) **When operating a power tool outdoors, use an extension cord suitable for outdoor use.** Use of a cord suitable for outdoor use reduces the risk of electric shock.
- g) **If operating a power tool in a damp location is unavoidable, use a residual current device (RCD) protected supply.** Use of an RCD reduces the risk of electric shock
- h) **Hold electric tools by isolated handles, because during the operation it can connect to flush conductor or its own cord.** If tool connects to voltage-carrying cables, voltage can pass to metal parts and it increases the risk of electric shock.

3 Personal safety

- a) **Stay alert, watch what you are doing and use common sense when operating a power tool. Do not use a power tool while you are tired or under the influence of drugs, alcohol or medication.** A moment of inattention while operating power tools may result in serious personal injury.
- b) **Use personal protective equipment. Always wear eye protection.** Protective equipment such as dust mask, non-skid safety shoes, hard hat, or hearing protection used for appropriate conditions will reduce personal injuries.
- c) **Prevent unintentional starting. Ensure the switch is in the off-position before connecting to power source and/or battery pack, picking up or carrying the tool.** Carrying power tools with your finger on the switch or energizing power tools that have the switch on invites accidents.
- d) **Never operate the tool, if blade covers are not in place.**
- e) **Remove any adjusting key or wrench before turning the power tool on.** A wrench or a key left attached to a rotating part of the power tool may result in personal injury.
- f) **Do not overreach. Keep proper footing and balance at all times.** This enables better control of the power tool in unexpected situations.
- g) **Dress properly. Do not wear loose clothing or jewelry. Keep your hair and clothing away from moving parts.** Loose clothes, jewelry or long hair can be caught in moving parts.
- h) **Do not put your hands inside the pipe during the operation.** Take care, that no one will put anything inside the pipe during the operation.
- i) **Do not let familiarity gained from frequent use of tools allow you to become complacent and ignore tool safety principles.** A careless action can cause severe injury within a fraction of a second.
- j) **Support the pipe to cut securely.** Pipe supports are more reliable for holding the pipe than bare hands.
- k) **If devices are provided for the connection of dust extraction and collection facilities, ensure these are connected and properly used.** Use of dust collection can reduce dust-related hazards.

4 Cutting procedures

- a)  **DANGER: Keep hands away from cutting area and the blade. Keep your second hand on auxiliary handle, or motor housing.** If both hands are holding the saw, they cannot be cut by the blade.
- b) **Do not reach underneath the workpiece.** The guard cannot protect you from the blade below the workpiece.
- c) **Adjust the cutting depth to the thickness of the workpiece.** Less than a full tooth of the blade teeth should be visible below the workpiece.
- d) **Never hold the workpiece in your hands or across your leg while cutting. Secure the workpiece to a stable platform.** It is important to support the work properly to minimize body exposure, blade binding, or loss of control.
- e) **Hold the power tool by insulated gripping surfaces, when performing an operation where the cutting tool may contact hidden wiring or its own cord.** Contact with a "live" wire will also make exposed metal parts of the power tool "live" and could give the operator an electric shock.
- f) **When ripping, always use a rip fence or straight edge guide.** This improves the accuracy of cut and reduces the chance of blade binding.
- g) **Always use blades with correct size and shape (diamond versus round) of arbour holes.** Blades that do not match the mounting hardware of the saw will run off-centre, causing loss of control.
- h) **Never use damaged or incorrect blade washers or bolt.** The blade washers and bolt were specially designed for your saw, for optimum performance and safety of operation.

5 Lower guard function

- a) **Check the lower guard for proper closing before each use. Do not operate the saw if the lower guard does not move freely and close instantly. Never clamp or tie the lower guard into the open position.** If the saw is accidentally dropped, the lower guard may be bent. Raise the lower guard with the retracting handle and make sure it moves freely and does not touch the blade or any other part, in all angles and depths of cut.
- b) **Check the operation of the lower guard spring. If the guard and the spring are not operating properly, they must be serviced before use.** Lower guard may operate sluggishly due to damaged parts, gummy deposits, or a build-up of debris.
- c) **The lower guard may be retracted manually only for special cuts such as "plunge cuts" and "compound cuts". Raise the lower guard by the retracting handle and as soon as the blade enters the material, the lower guard must be released.** For all other sawing, the lower guard should operate automatically.

d) **Always observe that the lower guard is covering the blade before placing the saw down on bench or floor.** An unprotected, coasting blade will cause the saw to walk backwards, cutting whatever is in its path. Be aware of the time it takes for the blade to stop after switch is released.

6 Power tool use and care

a) **Do not force the power tool. Use the correct power tool for your application.** The correct power tool will do the job better and safer at the rate for which it was designed.

b) **Do not use the power tool if the switch does not turn it on and off.** Any power tool that cannot be controlled with the switch is dangerous and must be repaired.

c) **Disconnect the plug from the power source and/or remove the battery pack, if detachable, from the power tool before making any adjustments, changing accessories, or storing power tools.** Such preventive safety measures reduce the risk of starting the power tool accidentally.

d) **Store idle power tools out of the reach of children and do not allow persons unfamiliar with the power tool or these instructions to operate the power tool.** Power tools are dangerous in the hands of untrained users.

e) **Maintain power tools and accessories. Check for misalignment or binding of moving parts, breakage of parts and any other condition that may affect the power tool's operation. If damaged, have the power tool repaired before use.** Many accidents are caused by poorly maintained power tools.

f) **Keep cutting tools sharp and clean.** Properly maintained cutting tools with sharp cutting edges are less likely to bind and are easier to control.

g) **Use the power tool, accessories and tool bits etc. in accordance with these instructions, taking into account the working conditions and the work to be performed.** Use of the power tool for operations different from those intended could result in a hazardous situation.

h) **Keep handles and grasping surfaces dry, clean and free from oil and grease.** Slippery handles and grasping surfaces do not allow for safe handling and control of the tool in unexpected situations.

i) **Do not use damaged or faulty blades or blade flanges.** Blade flanges and nuts are custom made for this tool to ensure optimum operating performance and safety.

7 Service

Have your power tool serviced by a qualified repair center using only identical replacement parts. This will ensure that the safety of the power tool is maintained.

Further safety instructions

The pipe saw must never be used in the following cases, if:

- There is water or another liquid, explosive gases or poisonous chemicals inside the pipe to be cut.
- The power switch is faulty.
- The power cable is faulty.
- The blade is bent.
- The blade is dull or in poor condition.
- The plastic components are cracked or have parts missing.
- The gripper unit is not properly tightened around the pipe or if it is warped.
- The blade guard cover or moving blade guard has been damaged or removed from the machine.
- The locking mechanisms do not work properly (UNLOCK - SWITCH).
- The pipe saw has become wet.

When you use the saw, the following factors shall be considered:

- Fasten the pipes to be cut properly so that the blade is not clamped between the ends of the pipes.
- Make sure that the pipe to be cut is empty.
- Make sure that the pipe is installed correctly.
- Make sure that the diameter and thickness of the blade is suitable for the saw and that the blade is suitable for rotational speed selected
- Never use axial friction force to stop the blade, let it stop freely.
- Check the parts of the blade protection.
- Never apply excessive force when using the pipecut.
- Never use the pipecut to lift the pipe when fixed on the pipe.
- Avoid excessive load on the electric motor.
- Always follow safety and operation manual and applicable regulations.

Description of the work

Read all manuals and warnings carefully. If warnings and instructions are not complied with, the risk of electric shock, fire and/or severe damage to life may occur.

Intended Use

PipeCut+Bevel 280 / 360 460 Pro Series

PipeCut+Bevel 280 / 360 / 460 Pro Series pipe saw is intended for use as a pipe fitter's tool at the job site.

PipeCut+Bevel 280 / 360 / 460 Pro Series can only be used to cut round pipes, with a diameter of:
 280 Pro Series 40 mm–280 mm (1.6"–11")
 360 Pro Series: 75 mm–360 mm (3"–16")
 460 Pro Series 100 mm–460 mm (4"–18")

Maximum wall thicknesses:

Steel 20 mm (0.8"), 230V
 12mm (0.4"), 120V

Plastic 45 mm (1.8"), 280 Pro Series
 50mm (2"), 360 and 460 Pro Series

PipeCut+Bevel 280 / 360 / 460 Pro Series pipe saw can be used to cut all normal pipe materials, such as steel, stainless steel, cast/ductile iron, copper, aluminum and plastic.

See the cutting depth table on page 15.

PipeCut+Bevel 280 / 360 / 460 Pro Series pipe saw is not intended for use in industrial production.

Use pipe holders to support the pipe being cut

Exact PipeCut+Bevel Pro Series pipe cutting system operation instructions

Cut+Bevel Pro Series features

Bevel depth and width is adjusted with depth adjustment roller (Fig. B). Turning the roller clockwise will make deeper and wider bevel and turning the roller counterclockwise will make smaller and thinner bevel.

Please note that the adjustment is effective only when motor unit is locked in down position. This adjustment is recommended to do before starting the cutting.

When using the machine on a new pipe size, adjust the cutting depth higher than needed prior to cutting. It is easier to make the cut deeper than lower by adjusting the depth adjustment roller when motor unit is in locked down position. Correct depth setting is confirmed with visual evaluation of the cutting result.

PipeCut+Bevel Pro Series machine locks to the same depth setting if depth adjustment roller is not moved. Therefore Cut+Bevel cuts can be made on same size pipes without any additional adjustment.

Beveling forces will push the saw to the right. To compensate these and achieve a straight cut, motor unit needs to be turned left. Size of this adjustment depends on pipe material, wall thickness and bevel size, one good adjustment position cannot be given.

To make the adjustment:

- Loosen the two screws on the body plate
- Turn bodyplate counterclockwise
- Tighten the screws

Changing the lower blade guard

When using the Cut+Bevel Diamond disc, be sure to use also the lower blade guard with wider opening on the bottom. Regular lower blade guard does not have work with Cut+Bevel Diamond disc.

Lower blade guard is changed as follows:

- Remove blade and blade flanges from the saw if fitted.

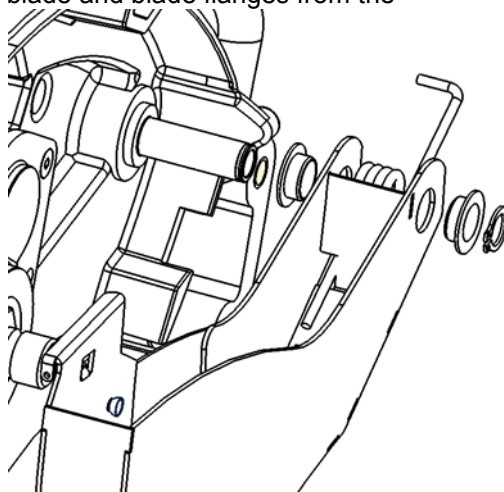

- Remove the retaining ring from the axle (right and Fig A2).

- Pull the lower blade guard, washer, spring and bushings of the axle. Note the locations of bushings and spring.
- Insert bushings to the lower blade guard to be installed
- Insert the lower blade guard with bushings, washer and spring on the axle. Be sure to locate the spring correctly.
- Test the correct function of the lower blade guard, it will return to low position when released and that it can move without any restriction.

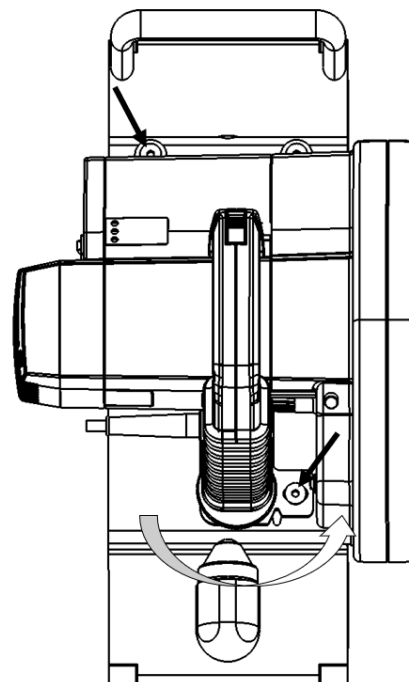
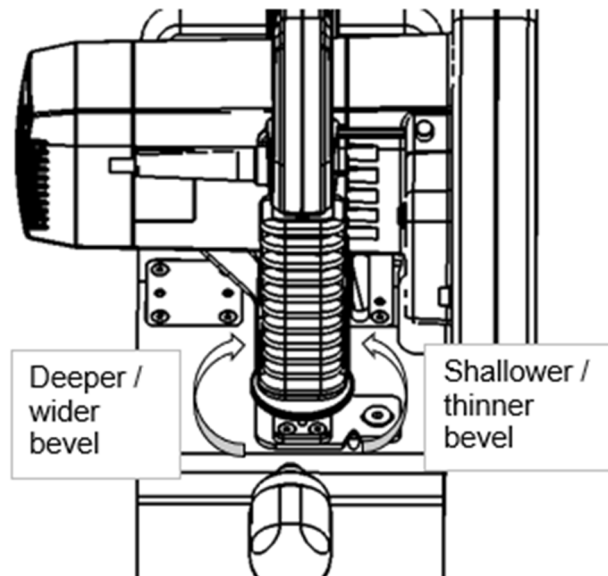

Before operation the tool

- For Cut+Bevel function, ensure that Cut+Bevel Diamond disc is installed to the saw.

- Make sure that lower blade guard is installed with the Cut+Bevel Diamond disc. Regular blade cover does not have big enough opening for the Cut+Bevel Diamond disc.

⚠ WARNING: Regular lower blade cover **must** be installed if saw is used with regular saw blade with cutting teeth.

- Ensure that motor unit is in the upright position.
- Check that the disc is correctly fitted, in good condition and suitable for the material to be cut.
- Ensure the pipe saw guide wheels rotate.
- Ensure the support wheels rotate.
- Check the operation of the lower blade guard.
- Ensure the pipe is empty.

Connection to the mains power supply

Ensure that the mains voltage is the same as indicated on the rating plate (Fig A / 13). Connect the pipe saw to the power outlet only after having checked the above points first.

Setting the pipe on supports

Use the system supports when cutting pipes. This will ensure safe working and optimum results. Work on flat surface. Place the pipe on two supports so that the cutting point is between the supports. Place two more support under both ends of the pipe. Check that all support wheels contact the pipe (adjust if required e.g. with pieces of lumber) (Fig B1). When cutting short and light weight pipes, place the supports so that the cutting point is outside supports (Fig B2). Support the pipe with your left leg, if required. Proper arrangements will prevent the blade from jamming as the pipe is cut through.

Attaching the pipe saw to the pipe

Open the pipe saw's gripper unit enough to suit the diameter of the pipe by rotating the adjustment handle located at the rear of the saw (Fig C / 1). If you are using laser pointer for position, Cut+Bevel Diamond disc 165 will cut the pipe 15mm to the right of the laser line. Fasten the pipe saw to the pipe by turning the gripper adjustment handle until the gripper grips firmly the pipe to be cut (Fig C / 2).

Lock the mechanism by turning the gripper safety (Fig C / 3). Hold the pipe in place and ensure that pipe saw moves freely in the direction the pipe is fed. For sake of safety ensure the pipe saw leads are to the left of the pipe saw. The pipe saw is now ready for cutting.

FIGURE B1

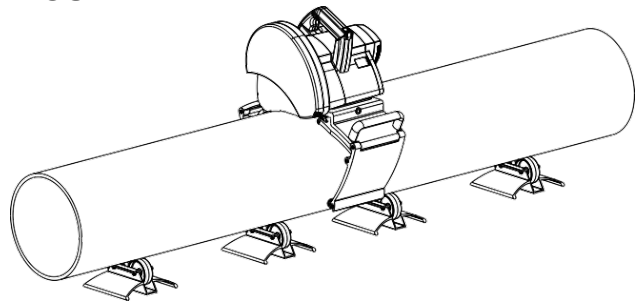

FIGURE B2

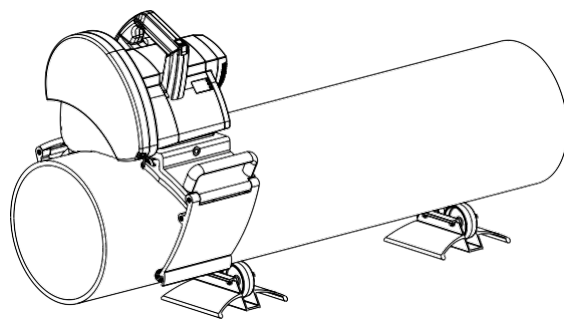
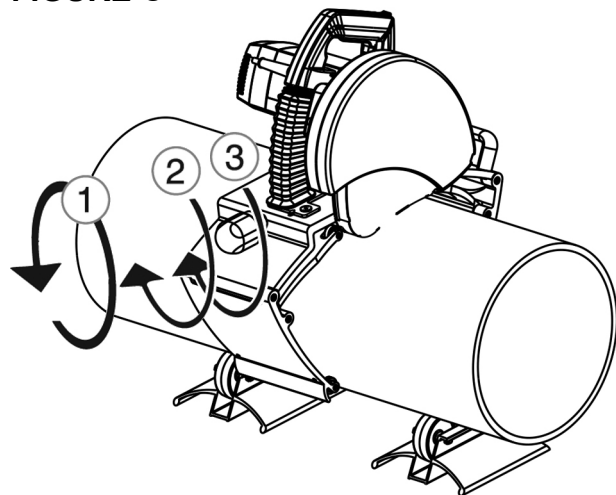

FIGURE C



Piercing the pipe wall

Grip the gripper firmly with your right hand and place your left foot on top of the pipe approximately 50 cm from the pipe saw. Turn the saw until it leans slightly forward (Figure F). When starting the motor, first of all release the power-switch locking lever (Fig D/1) and push the power switch all the way down (Fig D/2).

Before starting to saw, wait until the blade reaches full speed. Pierce the pipe wall by pressing pipe saw operating handle downwards slowly and evenly until the blade has cut through the pipe wall (at this stage the pipe must not rotate) and the motor unit is locked in the sawing position (Fig F / 1).

Look at the UNLOCK SWITCH during the piercing operation. When UNLOCK SWITCH is locked, i.e. the yellow mark disappears (Fig E / 1-2), the pipe saw is locked in the sawing position, and you can safely start sawing around the pipe.

Adjust bevel depth as needed with depth adjustment roller.

Cutting around the pipe

Start cutting by feeding the pipe saw forward and fix the pipe with your left foot (Fig F / 2). After that release the pipe (remove your left foot from the pipe) and turn the pipe saw backwards, whereby the pipe will also be rotated backwards (Fig G). Start a new feeding movement, and feed continuously forward ca. 1/6 of the pipe's circumference (Fig H). Repeat until the pipe is cut off. Select the feeding speed as per the material and the thickness of the wall. Too high speed can damage the blade, overload the pipe saw and give a poor cutting result.

When the pipe is cut off, push the UNLOCK SWITCH forward until the yellow mark is visible and the locking is released (Fig I / 1). Now raise the motor unit to starting position (Fig I / 2). Release the power switch (Fig I / 3). When the blade has stopped, open the gripper safety mechanism (Fig I / 4) and disengage the pipe saw from the pipe by loosening the gripper adjustment handle (Fig I / 5). Ensure that the moving lower blade-guard is lowered into safety position.

Should there be problems during piercing or cutting, abnormal sounds or vibrations and you have to interrupt cutting before the pipe is cut through, release the motor unit locking by pushing the UNLOCK SWITCH forward until the UNLOCK SWITCH is released and lift the motor unit up. Once the problem is cleared, start sawing again.

Never start the motor, when the motor unit is locked in sawing position or teeth of the blade contact the pipe to be sawn. Ensure, that the blade/disc is not connected to pipe during the motor operating.

FIGURE D

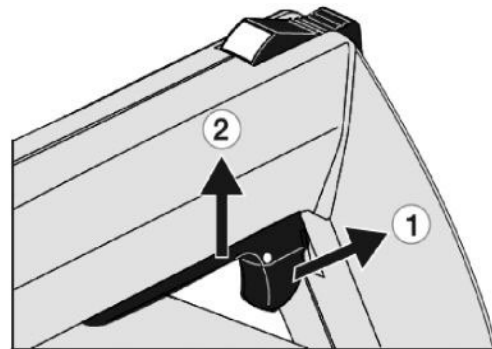

FIGURE E

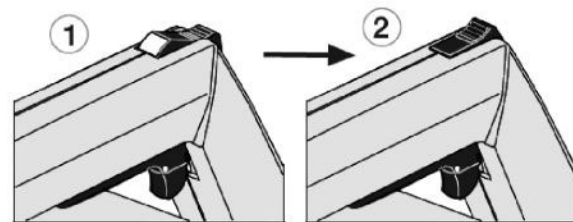

FIGURE F

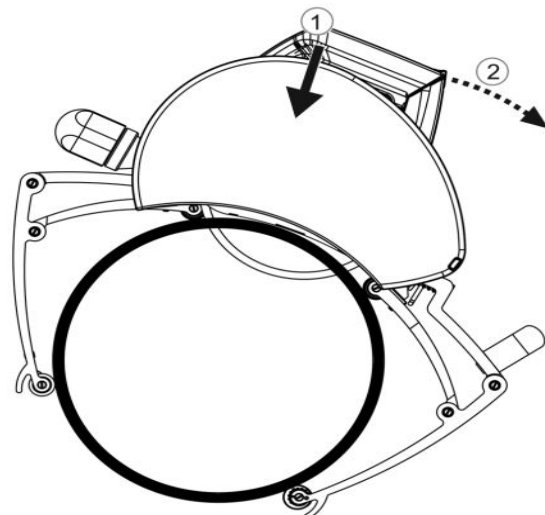
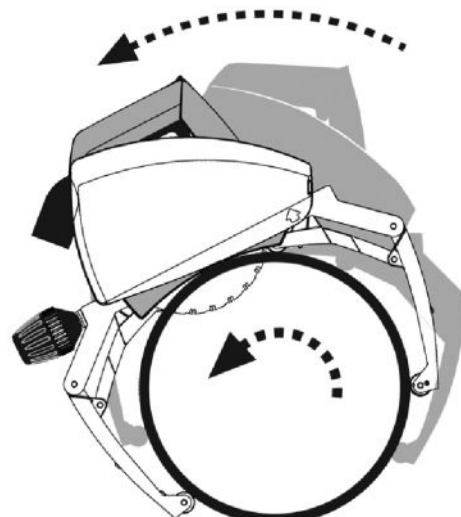

FIGURE G



Overload protector and blade RPM speed control **FIGURE H**

The saw has a two-speed blade RPM speed control (Fig A / 15). When cutting stainless or acid-proof steel use the lower RPM setting I. When cutting other materials use the faster RPM setting II.

The saw also has an overload protector which displays electric motor loading with three indicator lights (Fig A / 5).

Explanation of indicator lights (FIGURE J)

Normal operation	Green: ON Yellow: OFF Red: OFF
Normal power output	Green: OFF Yellow: OFF Red: OFF
Motor temperature high WARNING Normal power output	Green: OFF Yellow: Blinking Red: OFF
Motor current high WARNING	Green: OFF Yellow: Blinking Red: OFF
Decreasing power output	Green: OFF Yellow: OFF Red: OFF
Motor temperature protection active Power output very low, only cooling with free running	Green: OFF Yellow: OFF Red: Blinking
Temperature sensor faulty Power output low to finish the work	Green: OFF Yellow: ON Red: OFF

GREEN If green light is on, the motor temperature and power output are normal.

➔ **You can continue using the tool.**

YELLOW If yellow light begins to flash, the motor is hot and/or overloaded.

➔ **You should slow down the cutting speed** (It is possible, that you are using a worn-out blade)

RED If the red light begins to flash, motor power is automatically reduced to the minimum to protect the motor. Cutting is not possible.

➔ **Press the motor switch and let it run freely (UNDER NO LOAD) until the green light is on.**

ATTENTION! If the yellow light turns on when saw is powered, it indicates that the motor control unit has been damaged. You can finish the sawing, but the saw should take out for service. If the motor control unit is not repaired, the motor of the saw will get damaged.

Improving possible misalignment of the cut

The cut is affected by many factors, e.g. the size of the pipe, the material, the wall thickness, the quality of the pipe's surface, the roundness, welded seams, blade condition, feed rate, operator's experience. For this reason, the saw may move to left or right causing unperfect cut (see Fig K).

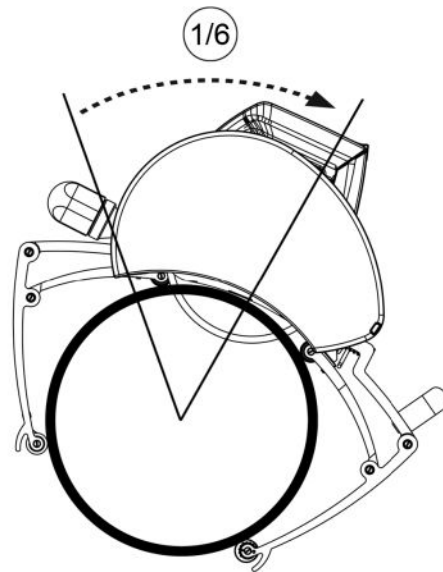

FIGURE I

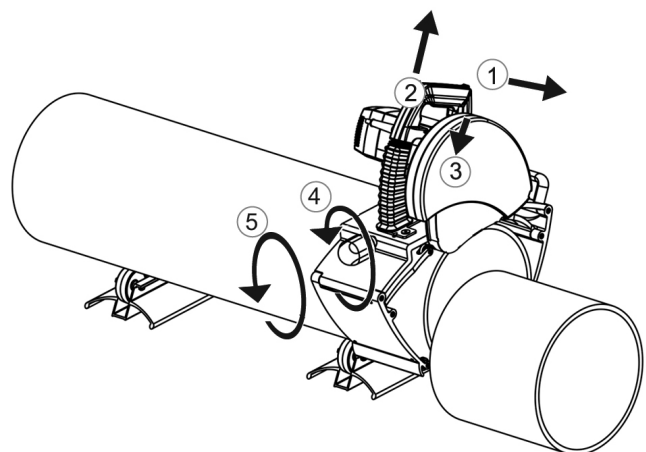
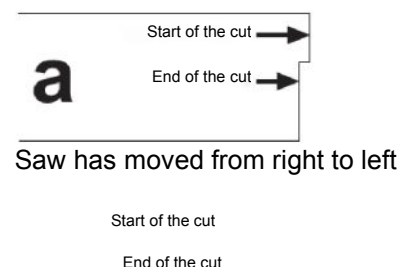

FIGURE J

	GO AHEAD
	WARNING
	RUN THE MOTOR UNTIL GREEN LIGHT IS ON

FIGURE K





Saw has moved from left to right

Cutting result adjustment for models Exact PipeCut+Bevel 280 / 360 / 460 Pro Series

Within the gripping devices of these models there are eight control wheels. One of them is the adjustment wheel (FIGURE A / 9). Please note that adjustment by this wheel concerns only the size of one pipe and material and the wheel may need to be adjusted again as the saw blade or disc wears out.

Adjust the wheel by releasing the locking screw (FIGURE L / 1) and turning the central part of the wheel CLOCKWISE or ANTICLOCKWISE to obtain the desired position (FIGURE L / 2), lock the wheel again (FIGURE L/3).

If the saw is moving from right to left (FIGURE K/a), turn the central part of the adjustment wheel so that "d" is smaller (FIGURE K/a). If the cutting is carried out according to Figure K/b, proceed as shown in Fig. K/b. It is recommended to lubricate the adjusting wheel periodically.

In these models the angle of the entire engine can be adjusted left or right. The laser beam can be used to aid in correct adjustment.

Adjustment stages

1. Mark the reference line precisely on the pipe at an angle of 90 degrees in the longitudinal direction.
2. Place the saw on the pipe so that the red line of the laser is next to the reference line at an angle of 90 degrees. Tighten the griper to the normal tension level. Check if the laser line and reference line are parallel. In FIGURE M/A the laser beam is not parallel with the reference line.
3. Release the two locking screws of the adjustment plate (FIGURE M/b 1 and 2).
4. Adjust the motor unit to the left or right as needed to get the laser beam and the reference line parallel. In FIGURE M/c the laser beam is parallel with the reference line.
5. Tighten the locking screws of the adjustment plate very tightly.

CAUTION! The adjustment indicator located in the back of the adjustment plate does give the exact measurement to adjust. The indicator shows only the direction of adjustment and the category of magnitude.

FIGURE L

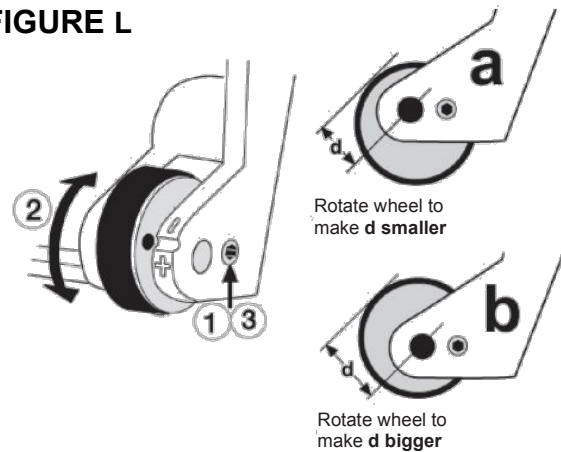

FIGURE M /a

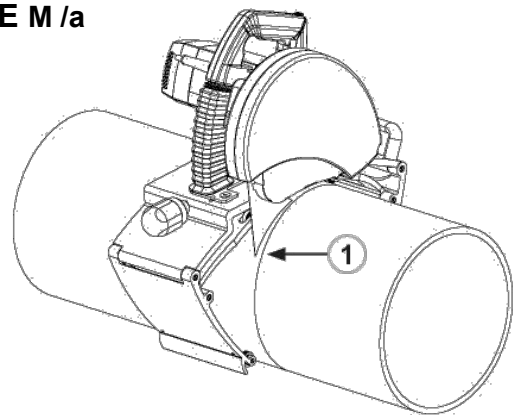

FIGURE M /b

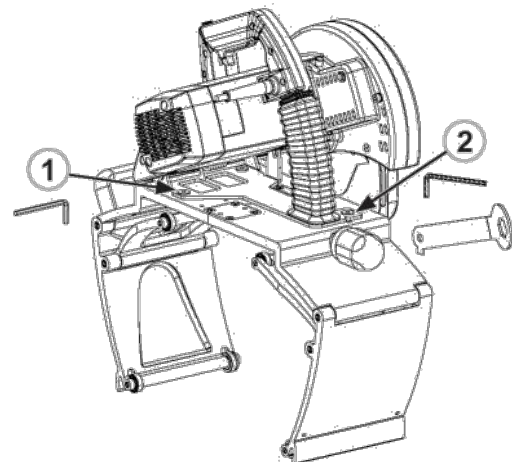
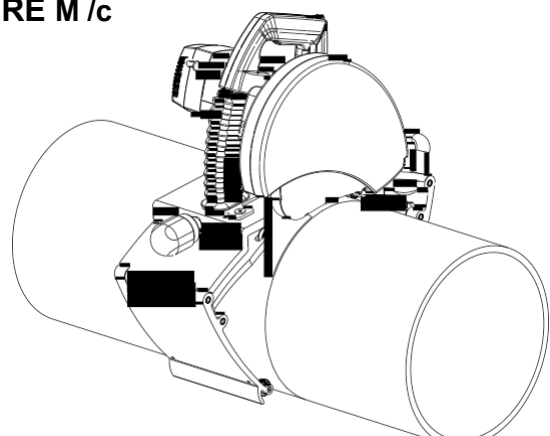

FIGURE M /c



CAUTION! If the motor unit is adjusted with the laser, the gripping device must be attached to the pipe with normal tension. This ensures that the saw fastening corresponds to the normal condition of operation.

If you are not satisfied with the cutting result of your saw and you need to adjust it again then always start by adjusting the eccentric adjustment wheel.

Installing and changing the saw blade

⚠ WARNING: To reduce the risk of injury, turn the unit off and disconnect it from the power source before installing and removing accessories, before adjusting or when making repairs. An accidental start-up can cause injury.

Remove the power plug from the socket.

Remove the blade guard cover (Fig N / 1) by opening the blade guard screw (Fig N / 2). Press the spindle-lock button (Fig A / 12) and simultaneously rotate the blade by hand until the spindle-lock button drops a further distance of about 7 mm. Now the rotation of the blade is prevented. Use the blade key to open the blade attachment nut. Remove the securing nut (Fig N / 3), the outer blade flange (Fig N / 4) and the blade (Fig N / 5).

Before installing a new blade, check that both blade flanges are clean. Place a new or sharpened blade on the back flange (Fig N / 6), so that the marked side of the blade is facing outwards and the arrows on the blade are facing in the same direction as the rotation direction markings on the inside of the blade cover. Ensure that the new blade goes right to the bottom on the back blade flange. Put the outer blade flange, and the securing bolt back in place. Press the spindle lock button and tighten the blade securing nut. Put the blade guard cover back in place and tighten the blade cover bolt.

When changing to Cut+Bevel Diamond disc, change also the lower blade cover to version with wide opening according to instructions on page 12.

⚠ WARNING: Regular lower blade cover **must** be installed if saw is used with regular saw blade with cutting teeth.

FIGURE N

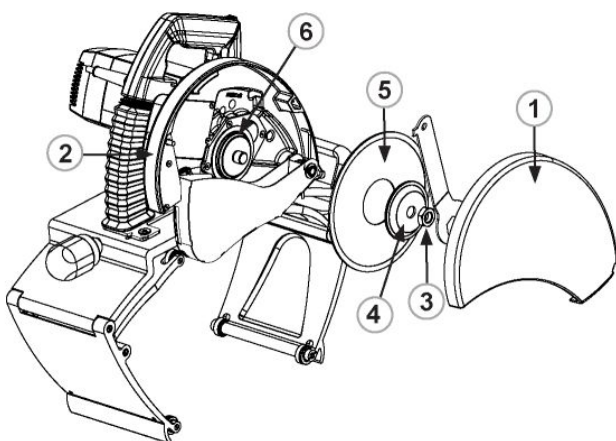

Maintenance and servicing instructions

Remove the power plug from the socket before servicing or cleaning the pipe saw. All maintenance operations carried out on the pipe saw's electrical components must be carried out by an approved service center or engineer.

Blade

Check the condition of the blade. Replace a bent, blunt, or otherwise damaged blade with a new one. Using a blunt blade can overload the pipe saw's electric motor and gearbox. When you notice that the blade is blunt do not continue cutting with it, as the blade may become so badly damaged that it will not be worth sharpening. A blade in sufficiently good condition can be sharpened a few times by a professional sharpening company. Diamond X Discs cannot be sharpened

Gripper unit

Clean the gripper unit regularly with compressed air. Lubricate the gripper's wheel axles (Fig O / 1 and 3) and its joints (Fig O / 2). Clean and lubricate also the gripper's trapezoidal screw and the two adjusting nuts on it (Fig O / 4).

Blade guard

When you have cut plastic pipes and then intend to start cutting metal pipes always clean the inside of the blade guards. Hot metal particles originating from metal cutting will heat up plastic particles, which may release toxic smoke. Make it a rule to clean the blade guard regularly and pay special attention to keep the moving blade guard movement from becoming obstructed. Lubricate the axis of the moving blade guard regularly.

As an extra equipment you can buy outer blade guard with connection for vacuum cleaner. For extra equipment see page 19.

Motor

Keep motor air vents clean to allow free airflow.

FIGURE O

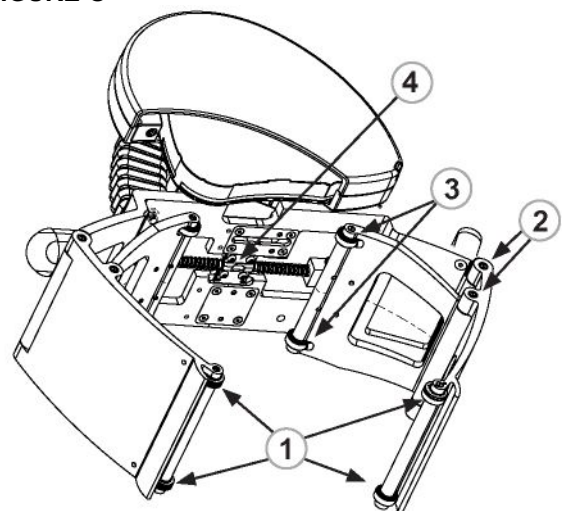

Plastic parts

Clean the plastic parts with a soft rag. Use only mild detergents. Do not use solvents or other strong detergents as they may damage the plastic parts and painted surfaces

Power cable

Check the condition of the power cable regularly. A faulty power cable should always be replaced at an approved service center. Correct use and regular servicing and cleaning will ensure the reliable operation of the pipe saw.

Environment

Separate collection. This product must not be disposed with normal household waste. When your Exact PipeCut machine is worn out, do not dispose it with normal household waste. This product must be recycled separately. Separate recycling of used products and packaging support recycling and recovery of materials. Reusing recycled materials helps preventing the pollution of the environment. According to local regulations it is possible to deliver household appliances to municipal rubbish depositories or to the dealer when purchasing a new product.

Guarantee

Warranty terms valid from 01.01.2018.

If the Exact PipeCut saw becomes unusable due to material or manufacturing defects within the Warranty Term, at our discretion we will repair the Exact PipeCut Saw or supply an entirely new or factory reconditioned Exact PipeCut Saw at no charge.

The Exact Tools Warranty Term is for 12 months from date of purchase.

The Warranty is only valid if:

- 1.) Copy of a dated purchase receipt is returned to the Authorized Warranty Repair Center or has been uploaded to our website at the time of warranty registration.
- 2.) The Exact PipeCut Saw has not been misused.
- 3.) No attempt has been made by non-approved persons to repair the saw.
- 4.) The Exact PipeCut Saw has been used in accordance with the operating, safety, and servicing instructions provide in these instructions.
- 5.) The Exact PipeCut Saw has been delivered to an Authorized Warranty Repair Center within the warranty period.

NOTICE! The Exact PipeCut Saw is to be shipped to the Authorized Warranty Repair Center freight prepaid. If the Exact PipeCut Saw is repaired under Warranty, the return shipment will be made freight prepaid.

CAUTION!

The following items or services are excluded for Warranty claims:

- Saw blades
- Carbon brushes
- Blade or attachment flange
- Blade attachment nut
- Normal wear
- Failures caused by misuse or accident
- Water, fire or physical damage
- Cables
- Adjustment of eccentric adjustment wheel
- If a wrong type of generator has been used as power source.

Exact Pipe Cut operation tips

Diamond blades can only be used for cutting cast or ductile iron pipes. This pipe material is not recommended to cut using to a blade of any other type

Clean the inside of the blade guards after cutting plastic pipes.

Smaller pipes are easier to cut by turning the pipe manually either on the table or on the floor.

CAUTION! Turn the pipe towards yourself when you do it manually. Don't turn the pipe too fast.

Check the condition of the blade regularly.

The cutting process is divided into two stages: first you need to cut through the pipe wall and then cut around the pipe.

Do not overload the saw while working without interruption. The pipecut will overheat and metal parts can become very hot. In this case, the motor and blade may become damaged. Use the pipecut system in accordance with its duty cycle being continuous cutting 2.5 minutes, then let it cool under no load for 7.5 minutes.

Maintain a uniform feed rate. This increases the lifespan of the blade. For example, a steel pipe with an outer diameter of 170 mm (6") and wall thickness of 5 mm (1/5"), the cutting time-is 15-20 seconds. Accordingly cast iron pipe with an outer diameter of 4" (110 mm) and wall thickness of 1/6" (4 mm), the cutting time is 20 – 25 seconds.

When not cutting, keep the motor unit in the up position. Never please the tool on the pipe with motor unit in locked down / cutting position.

Factors influencing blade lifespan:

- Pipe material
- Blade suitability for the pipe material
- Correct motor speed setting
- Pipe wall thickness
- Feed rate
- Smoothness of the pipe
- General user knowledge
- Cleanliness of the pipe
- Corrosion on pipe
- Weld seam on the pipe
- Blade speed

Factors influencing straightness of cutting:

- Blade condition
- Pipe wall thickness
- Feed rate
- Smoothness of feed
- General user knowledge
- Cleanliness of the pipe
- Pipe circumference
- Too loose or tight gripping device
- Too tight blade

Extra equipment 280 – 360 – 460 PS

Protection cover with vacuum cleaner connection for plastic cutting.

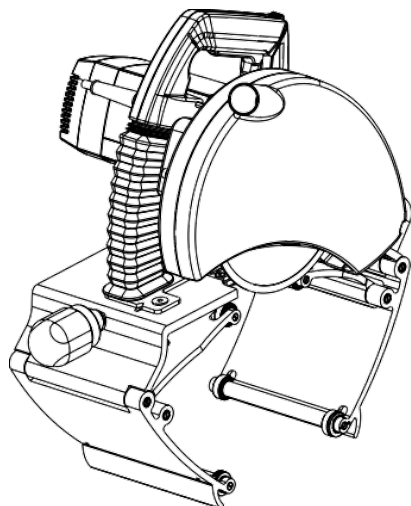
FIGURE P**Blade suitability**

Exact TCT: Suitable for cutting steel and all kinds of plastic pipe material

Exact Cermet: Suitable for cutting stainless steel and acid proof materials, steel, copper, aluminum and all kind of plastic pipe materials.

Exact ALU: Suitable for cutting aluminum and all kinds of plastic.

Exact Diamond: Suitable only for cutting cast and ductile iron pipe materials, also for concrete lined cast iron pipes.

Exact TCT 140
Exact Cermet 140
Exact ALU 140
Exact Diamond X 140

Exact TCT 165
Exact Cermet 165
Exact ALU165
Exact Diamond X 165

Exact Cermet 180
Exact ALU 180
Exact Diamond X 180

Exact Plastic 190

Exact Cut+Bevel Diamond disc 140
Exact Cut+Bevel Diamond disc 165

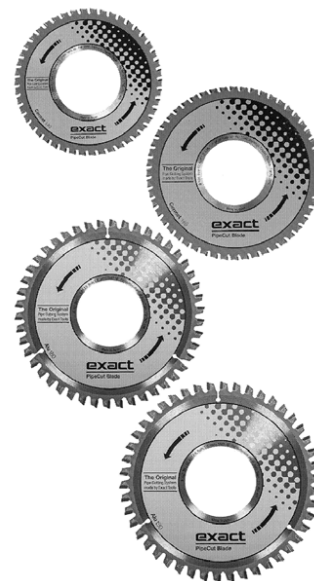

Due to continuous product development, the present manual may be modified. No changes will be reported separately.

For more information check www.exacttools.com

Theoretical maximum cutting depths

280 PS Max. Pipe wall / mm, with blade diameters 140, 165, 180, 190				
OD/mm	140	165	180	190
50	5,3	17,8	25,3	30,3
75	4,9	17,4	24,9	29,9
100	6,1	18,6	26,1	31,1
110	6,8	19,3	26,9	31,9
115	7,2	19,8	27,2	32,2
140	9,5	22,0	29,5	34,5
165	12,0	24,5	32,0	37,0
215	17,2	29,8	37,2	42,2
270	22,6	35,1	42,6	47,6
320	-	-	-	-
355	-	-	-	-

360 PS Max. Pipe wall / mm, with blade diameters 140, 165, 180, 190				
OD/mm	140	165	180	190
50	-	-	-	-
75	21,6	34,1	41,6	46,6
100	16,4	28,9	36,4	41,4
110	15,6	28,4	35,6	40,6
115	15,3	27,8	35,3	40,3
140	14,9	27,4	35,0	40,0
165	15,5	28,0	35,5	40,5
215	18,0	30,5	38,0	43,0
270	21,6	34,1	41,6	46,6
320	24,9	37,4	44,9	49,9
355	26,7	39,2	46,7	51,7

Max. pipe wall thicknesses in different pipe materials, which can be cut by Exact PipeCut+Bevel 280 / 360 / 460 Pro Series machines

European model 230V / 2500W

Steel pipes	Max.pipe wall thickness 20 mm / 0.78"
Stainless steel pipes	Max.pipe wall thickness 20 mm / 0.78"
Cast or ductile iron pipes	Max.pipe wall thickness 20 mm / 0.78"
Any on plastic, aluminum, cooper	Pipe wall thickness of these pipes is not limited

USA model 120V / 15A

Steel pipes	Max.pipe wall thickness 12 mm / 0.47"
Stainless steel pipes	Max.pipe wall thickness 12 mm / 0.47"
Cast or ductile Iron pipes	Max.pipe wall thickness 12 mm / 0.47"
Any types of plastic, aluminum, copper	Pipe wall thickness of these pipes is not limited

ATTENTION! Do not cut pipes with thicker than the above mentioned wall thickness.

ATTENTION! Check the status and condition of the blade before cutting