



RIAS

Reliably Innovative Advanced Systems

User Manual for Smart Home Under Cabinet Hoods

Professional-Style SMX Series™

30" / 36" Smart Home Under Cabinet Range Hoods

Model Numbers: RS-UCRH-S-30/36-1

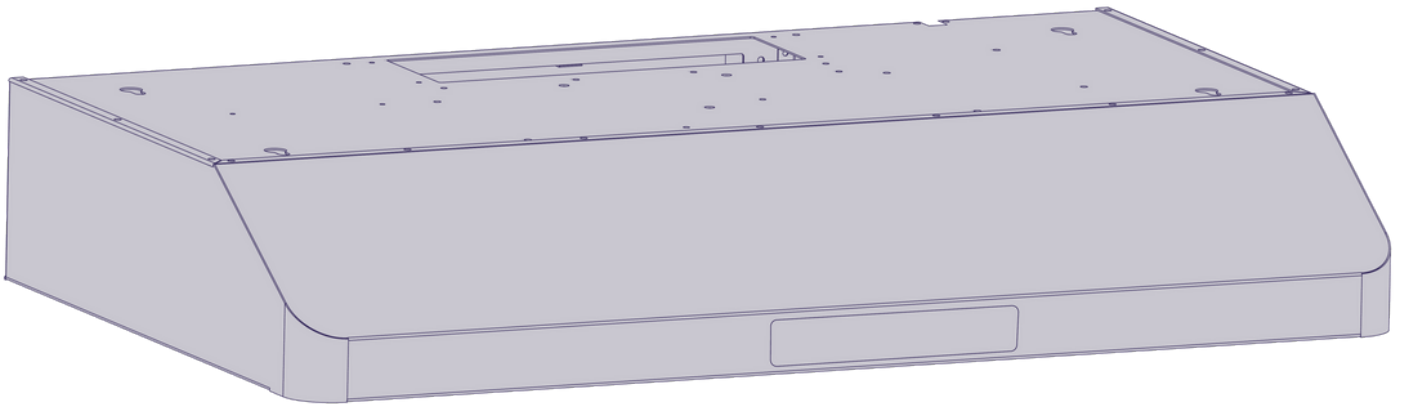

*MUST have Smart Life app installed & synced for these feature to work

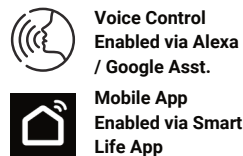
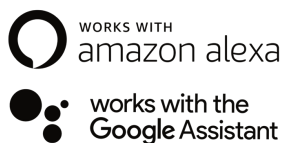

Table of Contents

- RIAS Welcome Statement..... pg. 1
- Your Safety (Part 1 - 2)..... pg. 2-3
- Range Hood Overview (Part 1 - 2)..... pg. 4-5
- Product Dimensions..... pg. 6
- Technical Parameters..... pg. 7
- Control Panel Interface..... pg. 8
- Installation (Part 1 - 4)..... pg. 9-12
- App & Smart Hub Connections..... pg. 13-25
- Continued Safety Information..... pg. 26
- *Cleaning & Maintenance*..... pg. 27
- Troubleshooting..... pg. 28
- *Warranty & Service*..... pg. 29
- Warranty Registration Tear-Out Mailer.... pg. 30



To Our Valued Customer:

Congratulations on your purchase of our most advanced smart home range hood available. Our unique combination of features, style, and IoT performance make us a great addition to your home.

To familiarize yourself with the controls, functions, and full potential of your new RIAS range hood, please read this user manual thoroughly.

RIAS appliances are designed and manufactured with performance as a primary focus. Should you ever have an issue with your range hood, first consult the troubleshooting section, which gives suggestions and remedies that may pre-empt a call for service.

Valuable customer input helps us continually improve our products and services, so feel free to contact our customer support team for assistance with all your product-related needs.

RIAS Customer Support

- **Telephone:** 1(949)209-9569
- **Email:** customerservice@rias-usa.com
- **Hours of Operation:** Mon – Fri, 9:00 a.m. to 6:00 p.m. Pacific Time
- **Website:** www.rias-usa.com

Thanks for choosing RIAS for your home. We are a company built on the foundations of quality, technology, and family. We are confident that your new RIAS range hood will deliver a top-level performance and enjoyment for years to come.

Sincerely,

The RIAS Customer Support Team

Your Safety - Part 1

Before getting started please read this user manual carefully before attempting to operate your new RIAS appliance, and store this manual in a safe place for future reference.

This RIAS appliance and its packaging are produced by a processes that minimizes waste and respects the environment. Please help us to continue this effort to protect the environment by using the appliance efficiently and dispose of the packaging in a responsible, recyclable manner. 

PLEASE READ THIS SECTION THOROUGHLY BEFORE ATTEMPTING TO OPERATE YOUR NEW RIAS APPLIANCE SYSTEM(S)

- 1)** There must be external flues / outside ventilation ducts installed in your home that are compatible with this ducted range hood model. Adequate space / airflow ventilation of the room must be present in accordance with local laws when the range hoods is used at the same time as appliances burning gas or other fuels (not applicable to appliances that only discharge the air back into the room). *Do not vent air byproduct into attics, inside walls, garages, or other rooms.*
- 2)** There is a fire risk if cleaning is not carried out in accordance with the instructions.
- 3)** Do not flambé under the range hood. This RIAS range hood is designed for residential use with a near commercial suction power, but is not a true commercial hood and should not be used as such.
- 4)** The byproduct ventilated by your RIAS range hood must not be discharged into a makeshift flue that has not been approved by a certified contractor for proper exhausting of fumes produced from appliances burning gas or other fuels (not applicable to appliances that only discharge the air back into the room). You should not utilize your RIAS range hood for recirculating the air byproduct back into the room.
- 5)** This appliance can be used by children aged 17 to adults aged 18+ years
- 6)** RIAS appliances are accessible for individuals with reduced physical or sensory capabilities via our ADA compliant smart home features (Smart Life App / Google home / Amazon Echo).
- 7)** If necessary supervision or instruction concerning use of the appliance in a safe way must be given, and a general understanding of the hazards involved must be present prior to use.
- 8)** Children ages 13 and below *should not be authorized to operate the appliance.*
- 9)** Cleaning and user maintenance shall not be made by children unless they are older than 13 and supervised.
- 10)** Keep the appliance and its cord out of reach of children less than 13 years.
- 11)** This RIAS range hood is meant for indoor use *ONLY*
- 12)** Do not make unauthorized modifications to your RIAS appliance, or use unauthorized 3rd party software / hardware without written consent by RIAS or as advertised.
- 13)** ALWAYS disconnect the power source before installing or modifying your RIAS appliance.
- 14)** Additional air exhausts / ventilation systems must be accordant with local laws as mentioned prior.

Your Safety - Part 2

Installation

- This appliance must be installed or repaired by a qualified technician only.
- It is dangerous to modify any part of this appliance.
- The manufacturer declines all responsibility in case of failure to adopt proper safety measures.
- Ensure the location in which this appliance is installed has good, permanent ventilation.
- In ducted mode, there must be one or more permanent air inlet. The air collected must not be discharged into a duct used to blow off smoke from other appliances fed with electricity.
- The distance between the stove-top to the lower part of the range hood must not be less than 27.6", We advise 27.6" - 30" MAX.
- Use an electrical connector with grounding that is compatible for your location.
- Check that the voltage of your outlet(s) are compatible to the appliance as indicated on the rating label.

Use

- Do not try to use your RIAS range hood without the grease filters.
- Do not use if the filters are excessively greasy due to potential fire hazard.
- Do not install above a stovetop with higher than average grills or with tall accessories that does not allow the advised spacing.
- Never leave open flames under the range hood with no pots, pans, or anything of use on top.
- Do not connect the hood to a duct that carries combustion fumes (e.g. fireplace).
- This product is designed for household use only and should never be used for commercial applications.
- After use, always ensure that all controls are in the "OFF" position.
- When frying with a gas flame, take particular care not to allow the oil or grease in the pan to catch fire.

Cleaning, Maintenance, and Service

- Clean the grease filters often (at least once monthly). Heavy oil deposits is a fire hazard. Hood surface should be cleaned with soft cloth and non-corrosive detergent.
- Important: Never attempt to repair this appliance by yourself. Always refer to qualified Service Technicians.
- For your safety, insist on original RIAS parts supplied directly by RIAS or an authorized RIAS distributor.
- Always switch off the electricity and unplug the connection before conducting maintenance or cleaning.

Electrical Cord

- Ensure the supply cord is not exposed to heat, chemicals or sharp objects.
- If the supply cord is damaged, it must be replaced by the manufacturer or its service agent or a similarly qualified person in order to avoid a hazard.

Range Hood Overview - Part 1

Ducted Installation Required

- Please note that this range hood must be installed with a ducted-style vent installation. A fire proof ducting system / extension of a 6 inch diameter is required. Please vent the fumes through a suitable outlet. In the ducted mode, only the aluminum grease filters are installed. Add-ons not approved or supplied by RIAS are installed at the consumer's own risk.

Stainless Steel Baffle Filters

- These filters are premium and do not need linings or mesh inside of the filters to provide near-commercial like collection capabilities of oils and cooking particles. They are constructed out of a premium stainless steel and can be cleaned in the dishwasher. They function by forcing the grease filled air to quickly and continuously as it passes through the filter.

High CFM Double Motors (Under Cabinet Hoods)

- RIAS under cabinet range hoods are equipped with high-powered CFM dual blower systems. The all-metal housing construction adds to the high-quality design and extends the longevity of your unit. These high CFM blowers can handle a HUGE array of cooking applications with an almost-commercial level of performance.

High CFM Centrifugal Blower System (Wall Mount Range Hoods)

- RIAS wall mount range hoods are equipped with high-powered centrifugal blower systems to easily match the dual-blower system while accommodating the wall mount designs.

Speed Control Options

- RIAS hoods are equipped with a 3 or 4 speed mechanical/electronic control.
- Use the low speed for simmering, medium speeds for variant light cooking methods (*EX boiling pasta, vegetables, breakfast items, etc.*), and the highest speed for deep frying or multi-pot heavy cooking.

Touchless Gesture Control System

- Some RIAS range hoods are equipped with a premium touchless gesture control system to sense your hand movement and adjust fan speeds in the detected directions accordingly.

Smart Home Connection (via Smart Life app)

- Each RIAS range hood has an integrated Bluetooth / Wi-Fi receiver compatible with your home network router. You must have an active connection to the same network as your mobile device before trying to connect your RIAS unit with the Smart Life application. The application is available for download from the Google Play and Apple App stores.

Range Hood Overview - Part 2

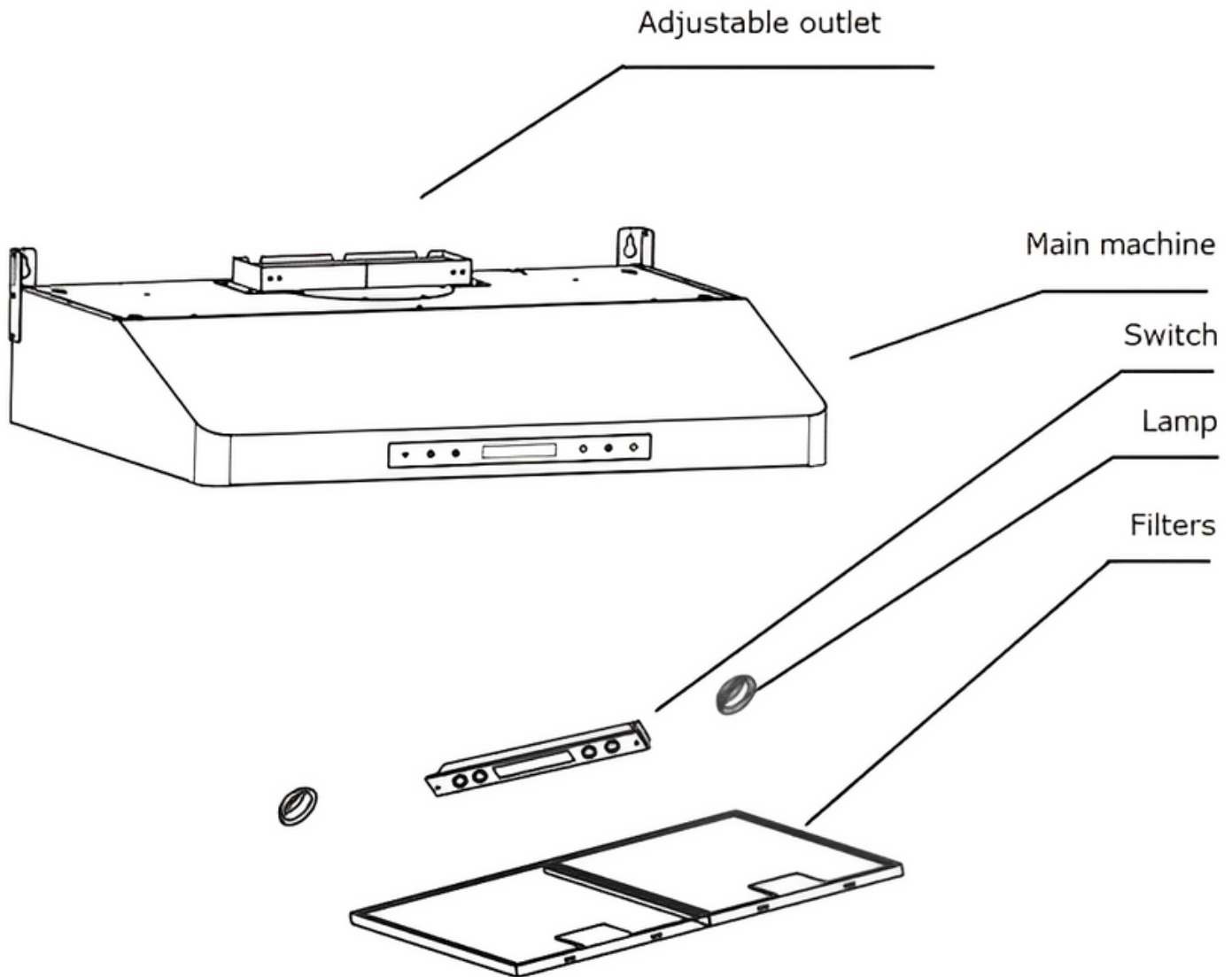

***NOTE:** Some RIAS range hood models may come with 2x carbon air filters included (pre-installed). Please check each blower under the baffle filters to confirm before use.

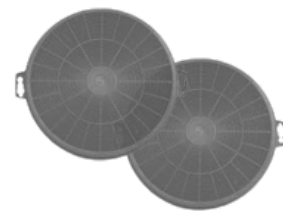

Product Dimensions (RS-UCRH-S-30/36-1)

RS-UCRH-S-30-1 (Dimensions in inches)

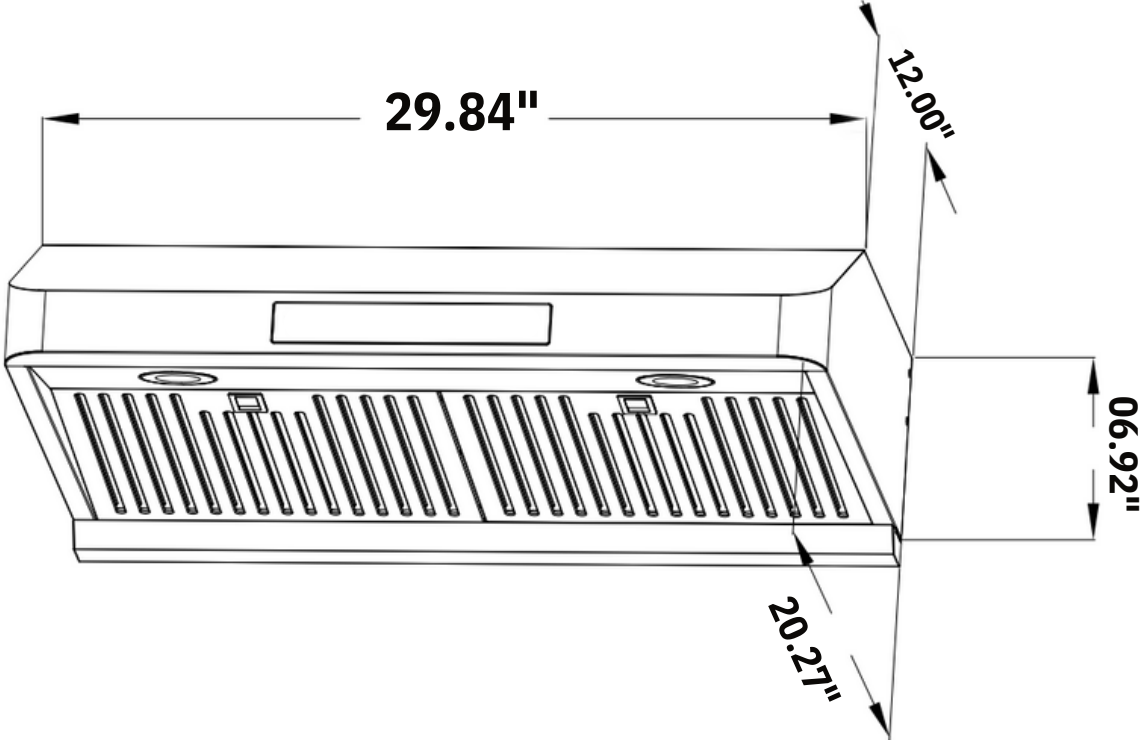

RS-UCRH-S-36-1 (Dimensions in inches)

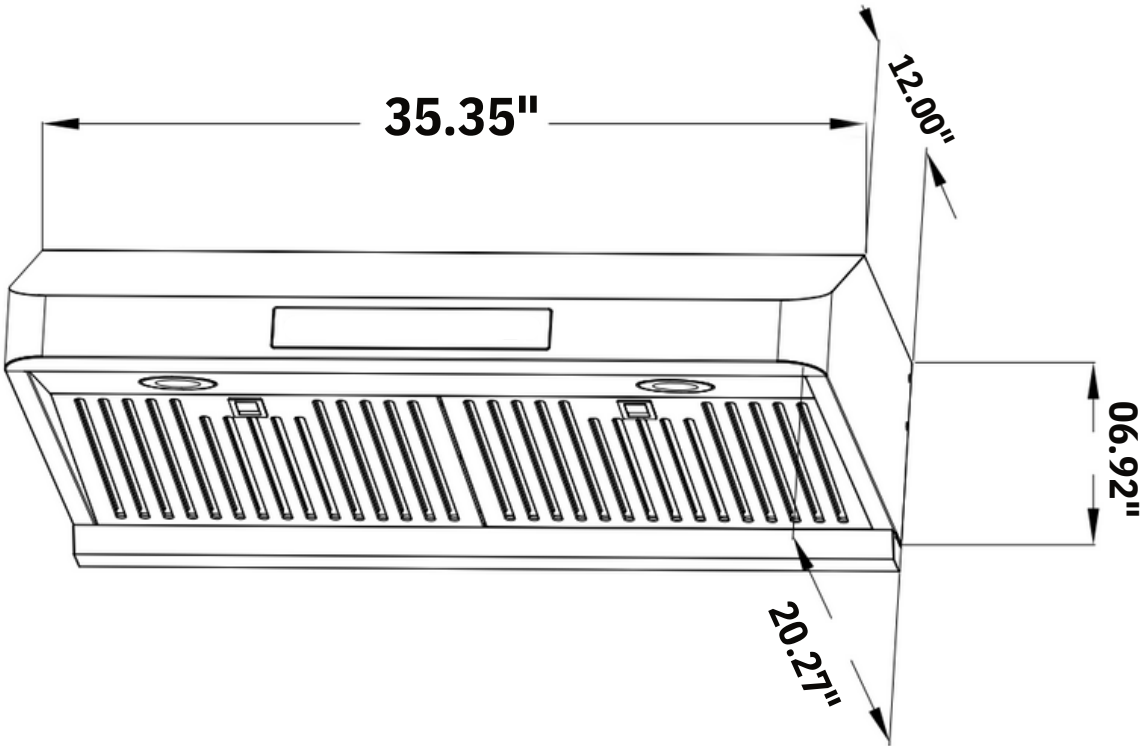

Product Technical Parameters

MODEL	RS-UCRH-S-30-1	RS-UCRH-S-36-1
Voltage	110V	110V
Frequency	60Hz	60Hz
Motor Power	90W*2	90W*2
Lamp Power	≤ 2 X 2W	≤ 2 X 2W
Air Volume	600CFM	600CFM
Noise Level	< 62dB(A)	< 63dB(A)
Air Output Diameter (Round)	6 Inch	6 Inch

Control Panel Interface

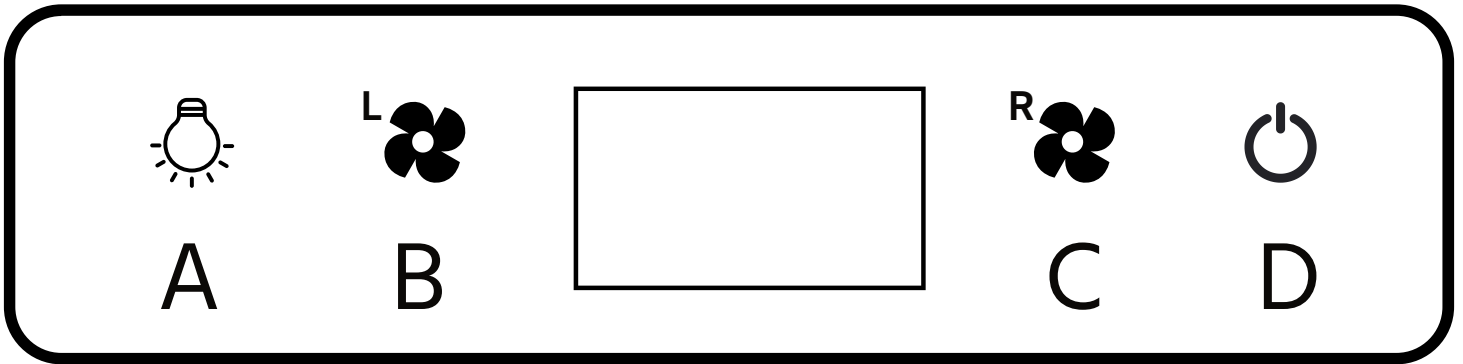

A) Activate Lights: Turn on / off LED lights.

Touching this part will power on / off the range hood lights. When the fans are off, touch button A for 3 seconds to set the clock. When the hour position on LED screen blinks, touch B and C to set hour. Touch A again to select your option. When the minute position on LED screen blinks, you can now touch B and C to set the minutes option. After making your selection you can touch A again to save the final settings.

B) Left Motor Plus: Increases the left blower fan only.

When the fan is running at the lowest speed the LED screen will show "F1". If you touch B once, the fan will run at medium speed showing "F2". Touching B a third time will set the fan at the highest speed showing "F3". A 4th touch will turn off the blower.

C) Right Motor Plus: Increases the right blower fan only.

When the fan is running at the lowest speed the LED screen will show "F1". If you touch C once, the fan will run at medium speed showing "F2". Touching C a third time will set the fan at the highest speed showing "F3". A 4th touch will turn off the blower.

D) Power: Turn on / off your RIAS range hood.

Touching this part will power on / off the range hood.

Smart Life Pairing Mode: Holding button D down for 3-5 seconds will initiate pairing mode, so that the range hood can be detected by the Smart Life app. You will notice 2 lights blinking in succession after holding the button down for the advised timeframe. This means the unit is actively searching for a pairing.

NOTE: Buttons B&C may be used to adjust timer settings after entering the pairing mode, if the LED screen is blinking. This features only works for certain RIAS range hood models. Some models may not include the option.

Installation - Part 1 - Overview

Pre-Installation Preparations

- Have the venting system go vertically from the range hood to the roof if possible.
- Have **24"-30" max distance between** the cooktop and the range hood. **27" is recommended.**
- Use uniformed duct(s) of 6" round duct or 3-1/4 x 10" rectangular duct or larger.
- Use metal-alloy vents only. A rigid metal vent is recommended. Semi-rigid aluminum vent is also acceptable for easy connection.
- Make sure there is a minimum of 24" of straight vent between the elbows if more than 1 elbow is used.
- Use minimal numbers of elbows and the shortest route for the venting system for a better performance.
- Use silver tap or duct tap to seal all joints in the venting system.
- Use caulking silicone to seal exterior wall or roof opening around the cap.
- Always keep the duct clean to ensure proper airflow.

May Be Included

(Depending on Model. If not included please purchase from 3rd party)

Contact customerservice@rias-usa.com for model-specific hardware details (type, sizes, etc.)

- 6 pcs - Large Screws
- 6 pcs - Large Wall Anchors
- 6 pcs - Medium Screws
- 6 pcs - Medium Wall Anchors
- 4 - 14 pcs - Small Screws
- 2 pcs - Metal Mounting Brackets
- 6" round aluminum duct
AND/OR
- 3-1/4" x 10" square aluminum duct

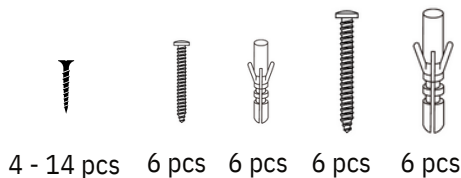

Vent Sizes

- For circle duct models: This range hood is 6" top venting through the roof or wall.
- For rectangle duct models: This range hood is 3-1/4 x 10" top or rear venting through the roof or wall.

Do Not

- End the venting system in an enclosed area indoors.
- Use a plastic or non-metal alloy style vent
- Use no more than three 90° elbows.
- Install 2 elbows together.
- Install the range hood outside of the recommended height.
- Reduce the duct size below the recommended size.

THESE ARE ONLY ADVISED METHODS. RIAS FIRMLY ADVISES THE CUSTOMER HIRE A PROFESSIONAL INSTALLER, AND RIAS DOES NOT TAKE RESPONSIBLITIY FOR FAULTY INSTALLATION METHODS. CUSTOMER INSTALLS AT THEIR OWN RISK.

Installation - Part 2 - Under Cabinet

SKIP TO STEP 3 IF YOU NEED TO WALL MOUNT

1) Assess available hardware and drill 4 holes on the bottom of the cabinet where installation is planned to occur.

2) Utilize the largest, most sturdy hardware / screws available (if included) to mount the range hood under cabinet. (Img. 1)

REQUIRED HARDWARE
THAT MAY BE INCLUDED:

- LARGE SCREWS

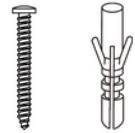

Img. 1

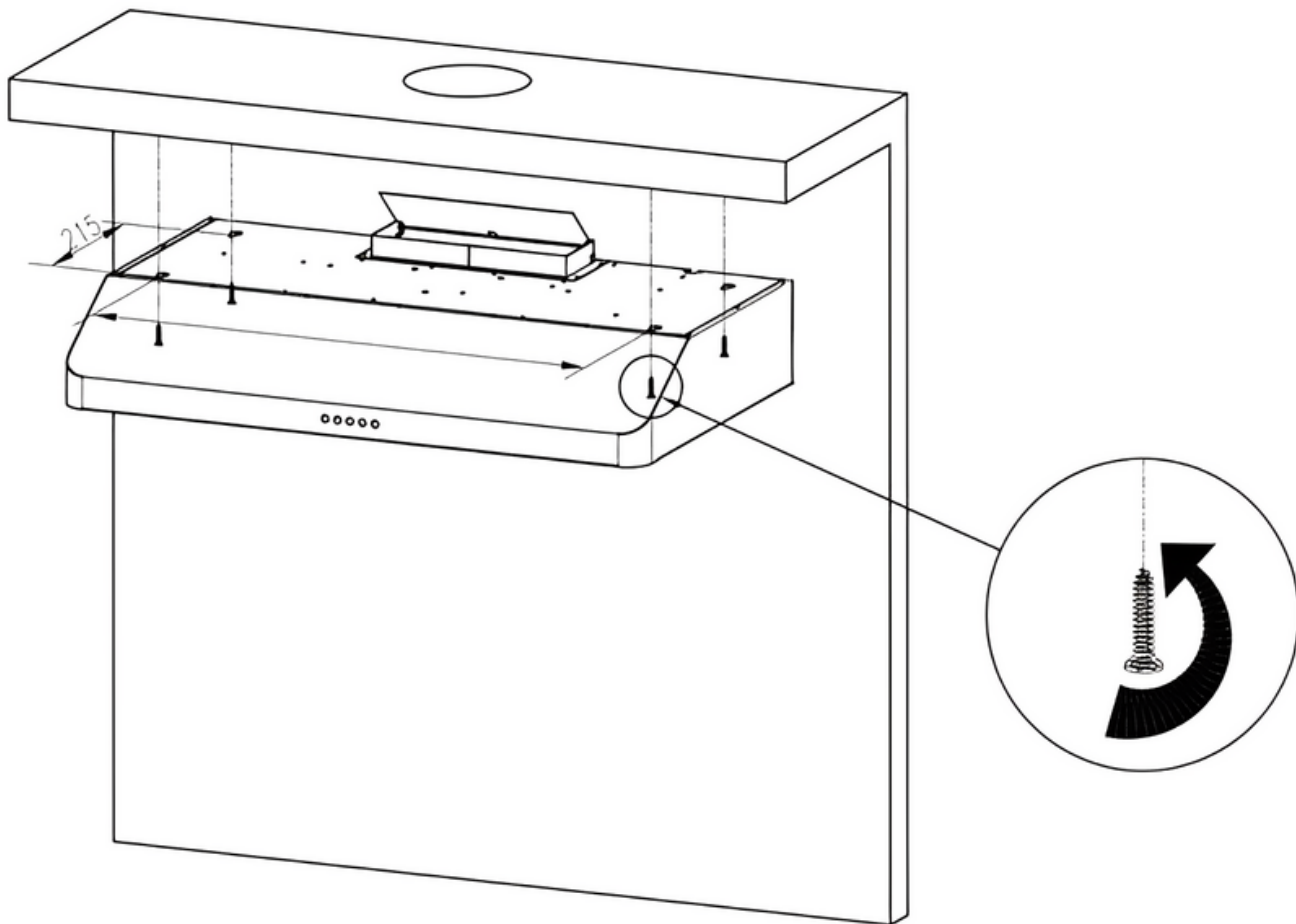

Installation - Part 3 - Wall Mounted

- 1)** Drill two screw holes to fit the included mounting brackets, and affix the brackets positioned behind the unit with adequate wall anchoring. (Img. 1)
- 2)** Assure the two mounting brackets are firmly affixed to the wall using the included screws and cement mounting brackets.
- 3)** Proceed to attach range hood to the attached mounting brackets accordingly.
- 4)** Use the included larger screws and plastic expansions behind the unit to strengthen the overall stability of the range hood. (Img. 2)

Img. 1

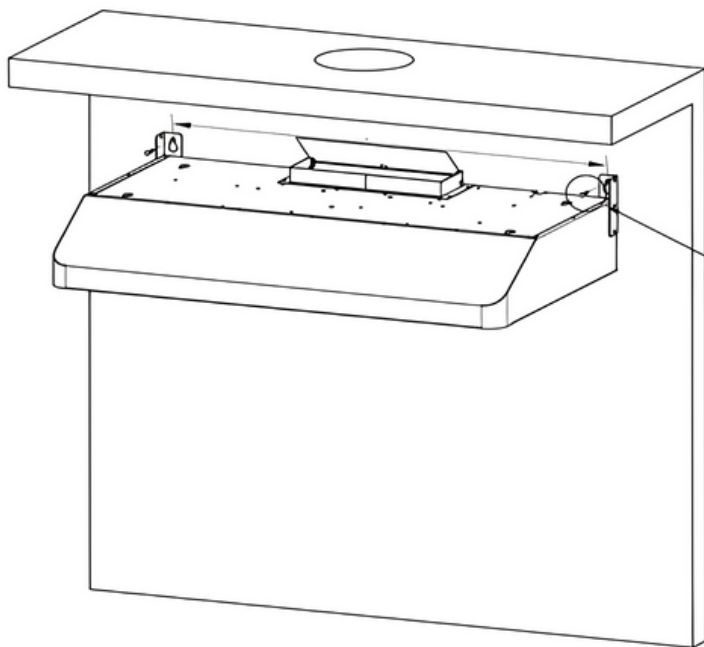

REQUIRED HARDWARE THAT MAY BE INCLUDED:

- LARGE SCREWS
- MEDIUM SCREWS
- MOUNTING BRACKETS

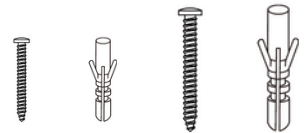

Img. 2

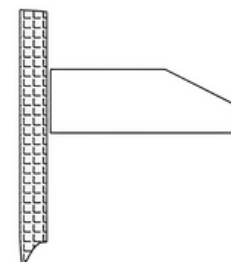
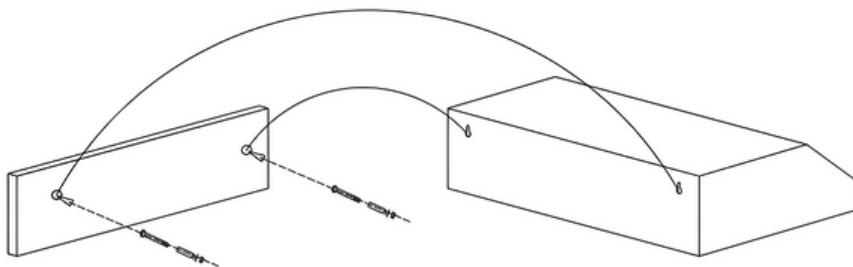

Installation - Part 4 - Installation Vent Type

REAR VENTING INSTALLATION

- 1)** Use 10 small screws to install the included top sealing plate to the open venting hole at the top of the range hood.
- 2)** Remove the 6 screws from the rear of the range hood holding the sealing plate onto the unit. Remove the sealing plate and store away for future use. (DO NOT DISCARD)
- 3)** Use the included small screws to install the rear square air duct outlet vent attachment.

TOP VENT INSTALLATION

- 1)** Depending on your kitchen vent direction, choose either the square or round air duct outlet vent attachment, which are both included.
- 2)** Install the desired air duct outlet vent attachment onto the top of the range hood by using the small screws to attach it firmly.
- 3)** Make sure to re-install the rear sealing plate back onto the unit (if it was removed prior.)

REQUIRED HARDWARE THAT
MAY BE INCLUDED:

- SMALL SCREWS



TOP SEALING PLATE



REAR SEALING PLATE



ROUND AIR DUCT VENT

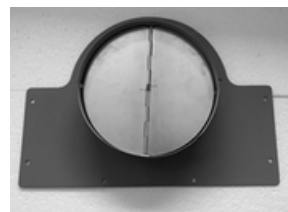

SQUARE AIR DUCT VENT

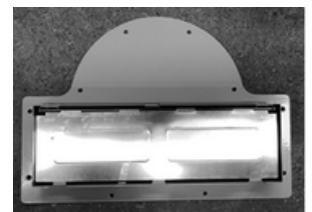

App & Hub Connection - Part 1

Download & Connect the Smart Life App

- 1) You must have an Android based phone or iPhone to use this App.
- 2) Search "Smart Life" in the Google Play store or Apple App store.
- 3) You can also scan the below QR codes to be linked to the correct download.



OR

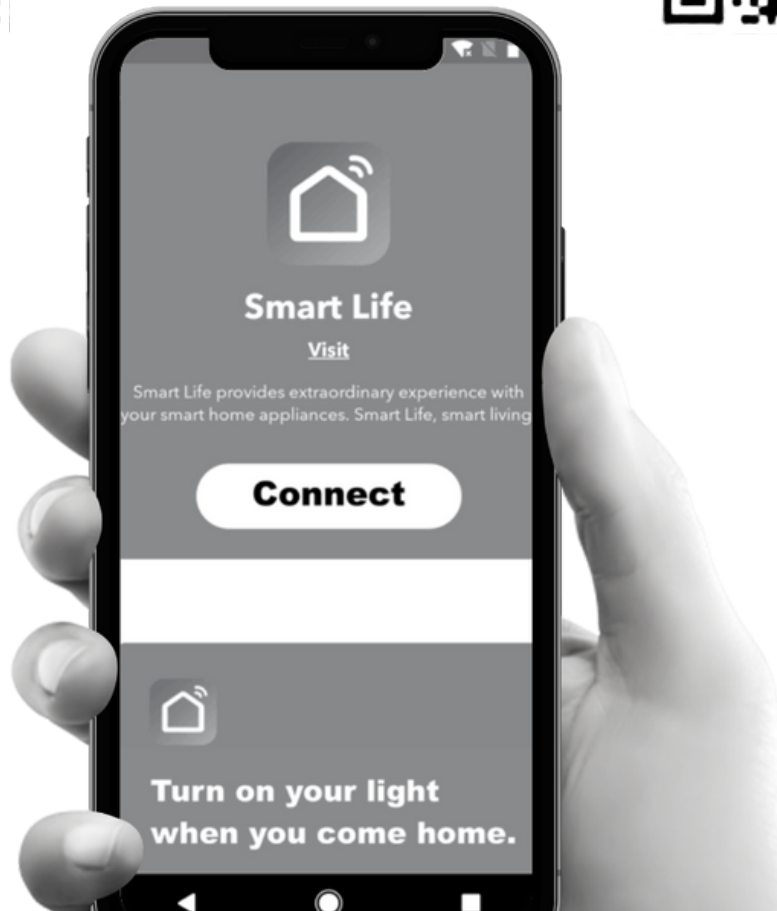

RIAS Range Hood & Smart Life App Pairing

4) When you log into the Smart Life app for the first time, you'll need to create an account (*if you have an account, skip this step*). After entering your RIAS range hood unit into pairing mode (hold power 3-5 seconds), Smart Life may automatically pick up the unit as a discovered device on the home menu. If not, please follow the below steps.

5) After creating an account successfully, follow the proceeding steps to sync your RIAS range hood to the Smart Life app device roster (*the operating procedures of Android and Apple IOS are extremely similar*).

6) Login to your Smart Life Account



7) Once logged in, click "Add Device"

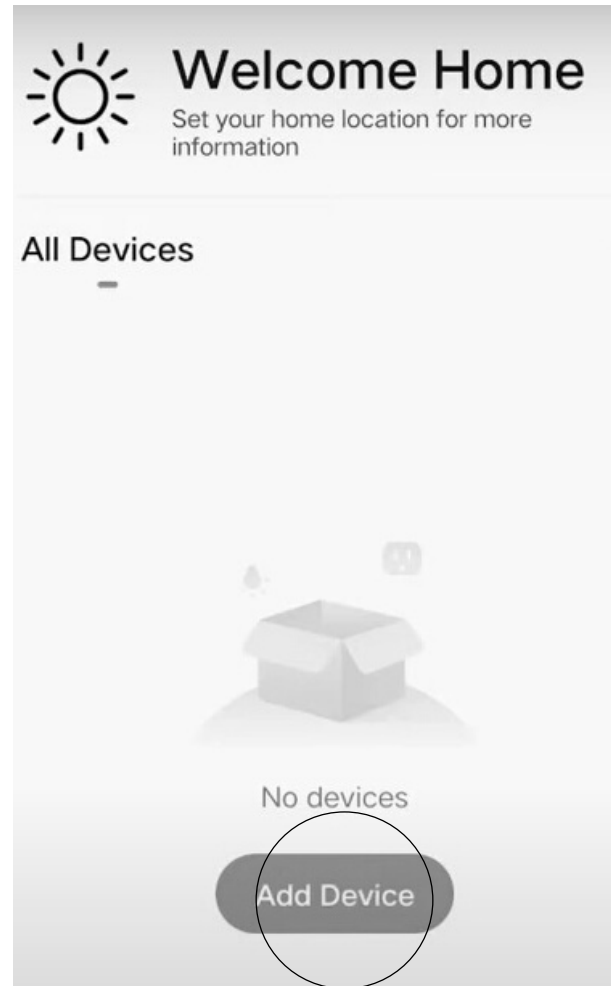

RIAS Range Hood & Smart Life App Pairing

8) Once on the device menu, select "Kitchen appliances".

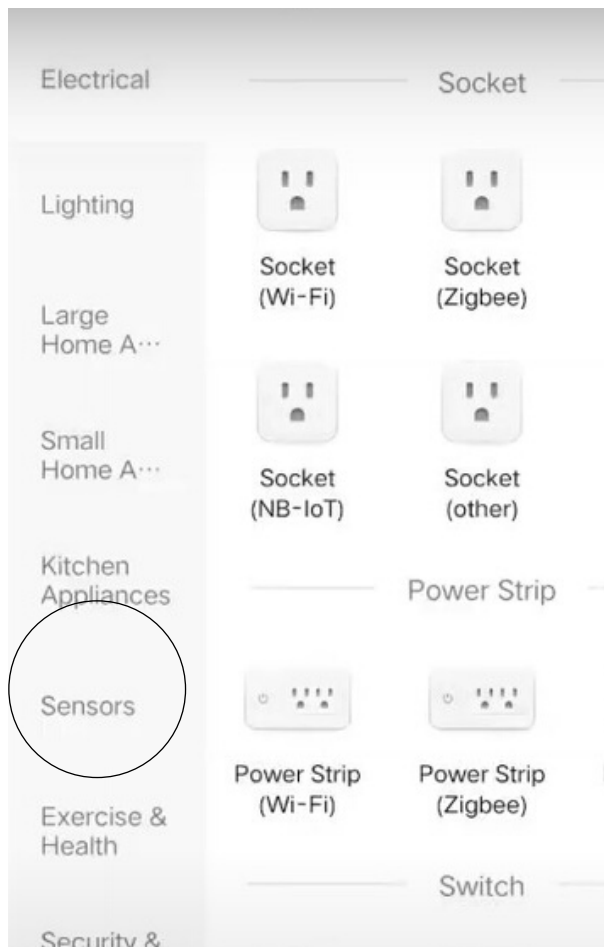

9) After clicking the kitchen appliances option, click "Kitchen Hood"

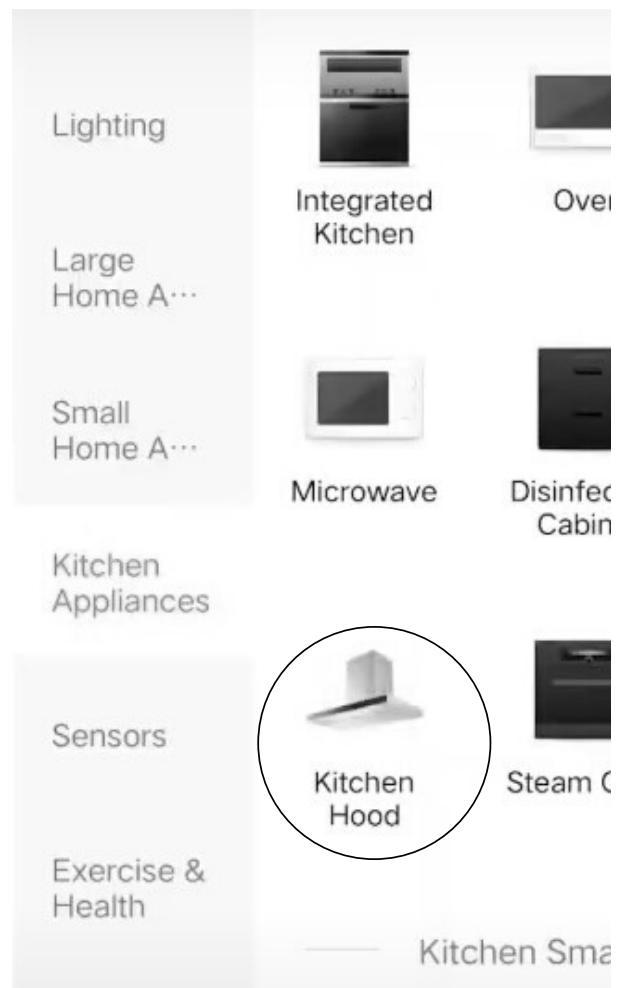

App & Hub Connection - Part 4

RIAS Range Hood & Smart Life App Pairing

10) After clicking the kitchen hood option you will be taken to the WiFi connection screen.

Login to your network.

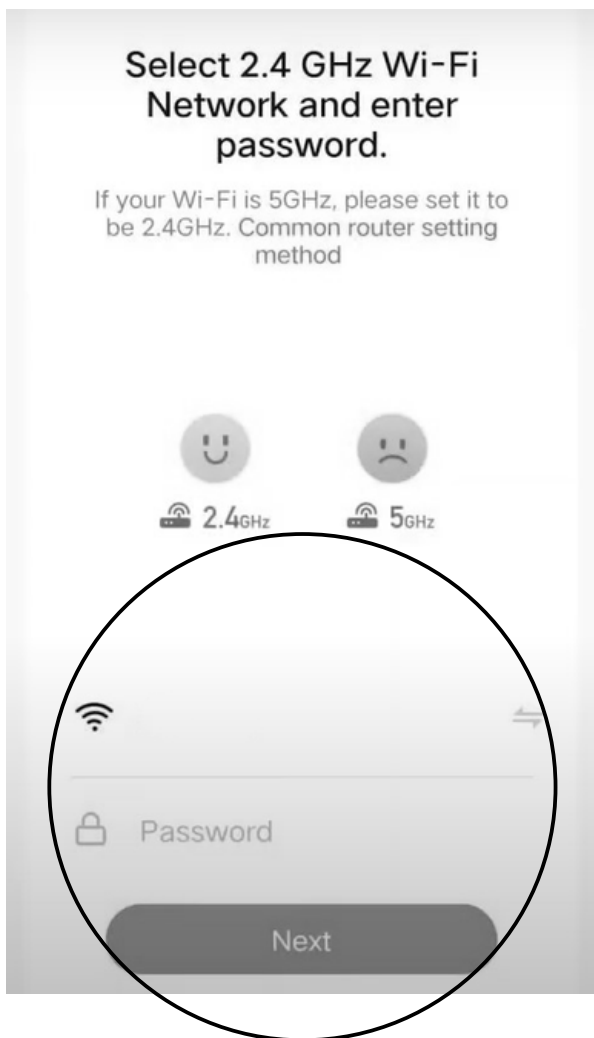

11) Make sure your RIAS range hood unit has entered pairing mode FIRST before attempting (steps on next page.)

After logging into your network, you will be taken to the net pairing screen. Please click "EZ Mode" in the top right for the quickest pairing option.

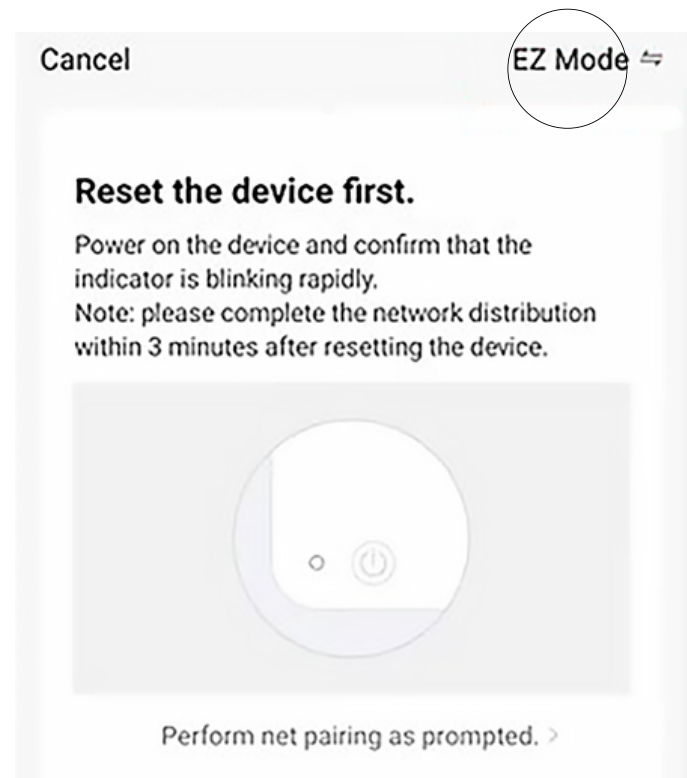

RIAS Range Hood & Smart Life App Pairing

12) * Enter pairing mode:

Press and hold down button D (power button) on your RIAS range hood for 3-5 seconds which will prompt the unit to enter pairing mode.

You will know your unit is in pairing mode if the dual lights on the LED display start to blink continuously after holding down button F for the required timeframe.

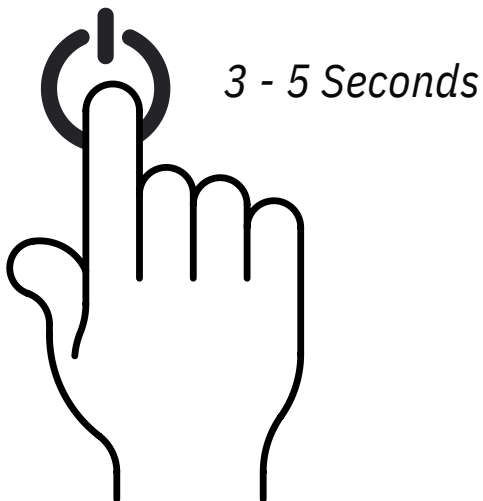

13) After entering pairing mode your unit should be picked up by your Smart Life app (depending on the manual or automated pairing process being displayed on the app.)



Add Manually



RIAS Range Hood & Smart Life App Pairing

14) If the pairing has been initiated correctly, and your RIAS range hood unit has been detected by Smart Life, you should be able to finalize the connection between the app and your RIAS range hood unit.

15) *SKIP STEP IF EZ MODE PAIRING WORKED You can also use the QR code below for a manual pairing option if the wireless pairing is not being detected (when on the prompted pairing screen within Smart Life.)

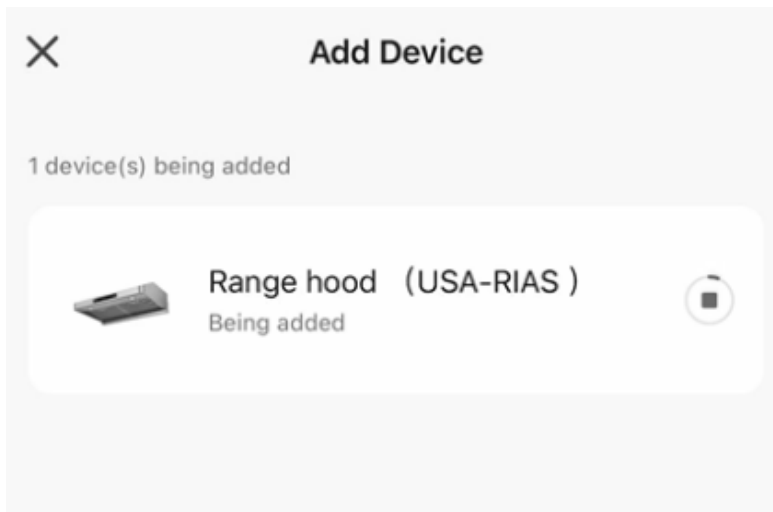

RIAS Range Hood & Smart Life App Pairing

16) *SKIP STEP IF EZ MODE PAIRING WORKED You may be prompted for a secondary WiFi connection request, and a manual unit selection pairing (via Bluetooth) if the EZ mode failed and 2-way AP mode pairing is initiated.

17) You now have access to remotely control your RIAS range hood via the Smart Life app user interface controls.

You MUST have your unit properly paired with the Smart Life app in order for Amazon Alexa or Google Home to pick up the unit for smart hub voice controls.

Enter Wi-Fi Information

Wi-Fi Name

Enter your Wi-Fi name or allow location access to find nearby Wi-Fi devices.

Password

Next

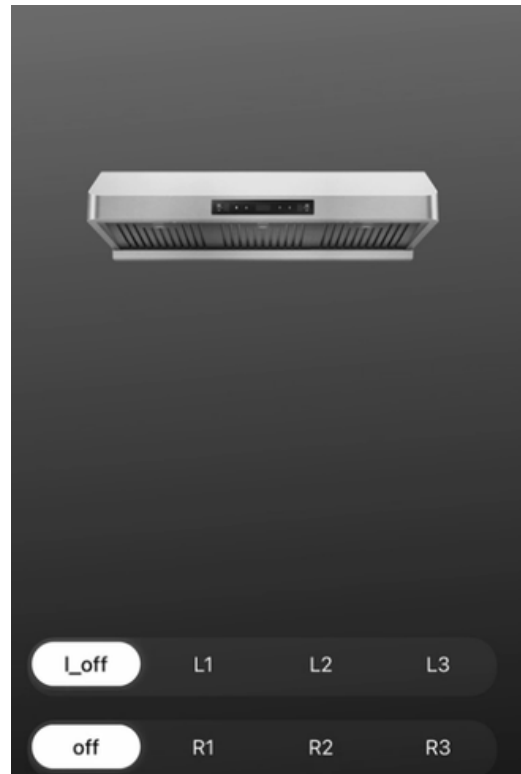

App & Hub Connection - Part 9

SKIP TO PART 12 IF YOU NEED GOOGLE HOME INSTRUCTIONS

RIAS Range Hood & Smart Life App Pairing

Amazon Alexa (Echo Devices)

18) Pre-Condition:

- You must have internet access and your device connected to the same Wi-Fi network (or have your RIAS rangehood connected to the Smart Life app, which is synced to the same network, depending on RIAS range hood model.)
- You must have your Echo device connected to the same network & preconditioned for proper setup, as advised by your specific device during general setup.
- You must download the amazon Alexa app on your mobile device that controls the amazon Echo device.
- You must have your Amazon account ready to go.
- Please make sure to change your device's name within the Smart Life app so that "Echo" may be able to recognize it.
- Smart Life account will need to be linked to Alexa for this to properly function.

RIAS Range Hood & Smart Life App Pairing

Amazon Alexa (Echo Devices)

19) Part 1: *Connect to Amazon Alexa app & Sync Smart Life account.*

- **1)** Open the Amazon Alexa app and click “more” in the bottom right corner.
- **2)** Now click “Skills & Games” that appears within the available on-screen menu.
- **3)** Once taken to the next step select “Discover” and click the search icon in the upper right corner of the screen.
- **4)** Search for “Smart Life” in the search box, and select the Smart Life app option that appears within the results section.
- **5)** On the next screen, click “Enable to use” (depending on operating system / app), then proceed to the next step.
- **6)** Click on the “Agree and Link” button that appears.
- **7)** When your Smart Life account has been successfully linked and the prompt has been displayed confirming so, please click the “Close” button.
- **8)** If a “Discover Devices” page appears, simply click cancel and go to the next step.

CONTINUE TO STEP 2 (AMAZON ALEXA (ECHO DEVICES)

RIAS Range Hood & Smart Life App Pairing

Amazon Alexa (Echo Devices)

20) Part 2: *Connect to Amazon Alexa app & Sync Smart Life account.*

- **9)** You may appear on a page that shows “Launch” or “Settings” for Smart Life within the Amazon Alexa app, which will require you to click “Launch”. Otherwise please click the devices option at the bottom of the Amazon Alexa app user interface screen.
- **10)** When taken to the next step, a screen showing discovered devices should be in view. Click “View” to go to the next required step.
- **11)** Click on “Range Hood” or whichever device name appears for your RIAS range hoods, then proceed to the next step.
- **12)** Now that your RIAS range hood & Smart Life account have been linked successfully to the Amazon Alexa app, you’ll have full access to the integrated voice control features.

Voice Control Commands / Formats:

- “ OK Alexa, turn on <device name>. Ex.: OK, Alexa, turn on “ Range Hood ”
- “ OK Alexa, turn off <device name>. Ex.: OK, Alexa, turn off “ Range Hood ”
- “ OK Alexa, set <device name> low . Ex.: OK, Alexa, set “ Range Hood ” low .
- “ OK Alexa, set <device name> high . Ex.: OK, Alexa, set “ Range Hood ” high .

RIAS Range Hood & Smart Life App Pairing

Google Assistant (Google Home Devices)

21) Pre-Condition:

- You must have internet access and your device connected to the same Wi-Fi network (or have your RIAS rangehood connected to the Smart Life app, which is synced to the same network, depending on RIAS range hood model.)
- You must have your Google Home device, or Android phone with google Assistant, connected to the same network.
- Precondition the Google device for proper setup, as advised by your specific device during general setup.
- You must download the newest version of the Google Home app, and/or the Google app (android only) that controls the Google device you plan to use for voice control features.
- You must have your Google account ready to go.
- You must select "English US" as the language of the phone or smart device.
- Smart Life account will need to be linked to Google Home for this to properly function.

App & Hub Connection - Part 13

RIAS Range Hood & Smart Life App Pairing

Google Assistant (Google Home Devices)

22) Part 1: *Connect to Google Home app & Sync Smart Life account.*

- **1)** Open the Google Home app and click the “ + ” button in the top left corner.
- **2)** Now click “Setup Device” that appears within the available on-screen menu.
- **3)** On this page please click “Works with Google” which will allow you to proceed to the next step.
- **4)** Search for “Smart Life” in the search box, and select the Smart Life app icon that appears within the results section.
- **5)** A prompt stating "Linking your Smart Life account" should appear, and once loaded, will take you to the next step.
- **6)** Click on the “Agree and Link” button that appears.
- **7)** When your Smart Life account has been successfully linked, the Google Home main page will show the name of the added device retrieved from your Smart Life app synced devices. Some times the option will say "Range Hood", though this is dependent on prior settings you may have inputted, or by RIAS range hood model.

CONTINUE TO STEP 2 Google Home Assistant (Google Home Devices)

RIAS Range Hood & Smart Life App Pairing

Google Assistant (Google Home Devices)

23) Part 2: *Connect to Google Home app & Sync Smart Life account.*

- **8)** Discovered devices on Google Home can only show what has been previously synced successfully with the Smart Life app.
- **9)** You should be able to select the option that is now available on your Google Home main page.
- **10)** Congratulations, you can now use Google Home voice control features to remotely control your RIAS range hood.

Voice Control Commands / Formats:

- “ OK Google, turn on <device name>. Ex.: OK, Google, turn on “ Range Hood ”
- “ OK Google, turn off <device name>. Ex.: OK, Google, turn off “ Range Hood ”
- “ OK Google, set <device name> low . Ex.: OK, Google, set “ Range Hood ” low .
- “ OK Google, set <device name> high . Ex.: OK, Google, set “ Range Hood ” high .

Continued Safety Information

- 1)** DO NOT attempt to install this range hood by yourself. Please consult a qualified professional.
- 2)** The minimum distance between the surface of GAS stove/range and the lowest part of the range hood should be at least 27.6 inches. If installation instructions of the gas stove specify a greater distance, please take that distance into account.
- 3)** There should be adequate ventilation in the room where the range hood is used if gas or other fuels are burning.
- 4)** The venting air from this range hood must not be discharged into a flue that is used for exhausting fumes from appliances burning gas and other fuels.



- 5)** All advised & non-RIAS advised regulations concerning the discharge of air have to be fulfilled. RIAS does not take responsibility for negligence on the consumer's end.
- 6)** Again, DO NOT leave open flame or flambe under range hood.
- 7)** This range hood is not intended for use by young children unless they have been supervised by a responsible adult.
- 8)** When conducting maintenance of this range hood and/or changing the hood light bulb, please make sure that all power switches are off.
- 9)** To prevent leaking, make sure detergent or dish soap DOES NOT flow into the electric box and switches when cleaning inside of the range hood.
- 10)** If range hood is not cleaned properly, in accordance to the manual, there is a risk of fire hazard.
- 11)** RIAS USA LLC does not accept responsibility of negligence from 3rd parties (such as installers, service technicians, Google, Amazon, or Tuya.)

Cleaning & Maintenance

- 1)** For your safety, please make sure to pull out range hood electric plug and shut off power before maintenance.

- 2)** Clean the inside and outside of the range hood with warm water containing neutral detergent, and dry the surface with a piece of dry cloth. To avoid potential damages to the surface, DO NOT scrub the surface with rough materials, such as cleansing ball. Gloves are recommended to use when cleaning inside of range hood, to avoid possible injury to your hands. Depending on the usage of range hood, cleaning can be conducted every three month or longer.

- 3) IMPORTANT:** DO NOT use your hands to tools to touch the wind wheel when cleaning inside of range hood. This will prevent deformation or malfunction of the wind wheel.

- 4)** When cleaning the grease filter panel, first press the spring on the edge of the filter to dismantle the filter OR grab the handle of the filter, and lift it off the range hood. You can either wash these filters in dishwasher or wash them by hand. When washing filters by hand, use either commercial grade detergent with a soft brush or apply baking soda on the surface of filter and pour white vinegar to gently brush grease off. And then clean the filters thoroughly with clean warm water. Please make sure the filters are fully dried before installing them back on. Depending on the usage of range hood, filters should be cleaned every month or so.

- 5)** DO NOT clean grease filters with combustible detergents, chemicals, or oils / gasoline not meant for kitchen environments.

Troubleshooting (RS-UCRH-S-30/36-1)

Issues	Possible Cause	Solution
Light on, but motor does not work	Fan switch turned off	Select a fan switch position.
	Fan switch failed	Contact customer service.
	Motor failed	Contact customer service.
Light does not work, motor does not work	House fuses blown	Reset/Replace fuses.
	Mains power cable is loose or disconnected	Replug main power cable to power outlet. Switch power outlet on.
Lights not working	Broken or faulty bulbs	Replace blubs as instructed in manual.
Insufficient suction	The distance between the cooker hood and the gas top is too far	Refit the range hood to the correct distance.
The range hood inclines	The holding screw is not tight enough	Tighten the hanging screw and make it horizontal.

Warranty & Service

Getting Help

Before calling for service, review the troubleshooting page, and familiarize yourself with each RIAS appliance's warranty terms/conditions.

If you cannot resolve the issue, call a RIAS Customer Service Representative, Mon – Fri, 9:00 a.m. to 6:00 p.m., Pacific Time: 1(949)209-9569, or visit our website: www.rias-usa.com

Warranty

What is Covered

CERTIFICATE OF WARRANTIES:

RIAS RANGE HOODS WITHIN THE 50 STATES OF THE USA, THE DISTRICT OF COLUMBIA, AND CANADA

FULL 3-YEAR WARRANTY

- The warranty applies only to the RIAS range hoods sold to the first-use purchaser, starting from the date of original retail purchase or closing date for new construction, whichever period is longer. Warranty is valid on products purchased brand new from a RIAS authorized retailer / dealer, or other sellers authorized by RIAS or an authorized RIAS distributor.
- If your RIAS product fails to function within 3 years of the original purchase date, due to material or manufacturing defect, RIAS will remedy it without charge to you.
- All cosmetic damage (e.g., scratches, blemishes, etc.) to the product or included accessories must be reported to RIAS within 60 days of the original purchase date to qualify for warranty coverage. Product must also be registered and issued a warranty ID number.
- Consumable parts such as filters and light bulbs are not covered and are the responsibility of the purchaser.

LIMITATIONS OF COVERAGE

- Service will be provided by a RIAS designated service company during regular business hours. These providers are independent entities and are not agents of RIAS USA LLC.
- Dealer display and model-home display products with a production date greater than 5 years, products sold “As Is,” and products installed for non-residential use, including but not limited to: religious organizations, fire stations, bed and breakfast, and spas carry a 1-year parts warranty only.
- All delivery, installation, labor costs, and other service fees are the purchaser's responsibility. Warranty is null and void on products that are altered, defaced, or missing serial numbers and tags.
- The owner must provide proof of purchase or closing statement for new construction upon request. All RIAS products must be accessible for service.
- Warranty is null and void if non-ETL or non-CUL approved product is transported from the U.S.A.

What Is Not Covered

- Slight color variations because of differences in painted parts, kitchen lighting, product placement, etc.; this warranty does not apply to color variation.
- Service calls to educate the customer on proper use and care of the product.
- Service fees for travel to islands and remote areas, including but not limited to: ferries, toll roads.
- Consequential or incidental damage, including but not limited to: food/medicine loss, time away from work, restaurant meals.
- Product failure when used for commercial, business, rental, or any non-residential-consumer use.
- Product failure due to improper product installation.
- Replacement of house fuses, fuse boxes, or circuit breaker reset.
- Product damage due to accident, fire, flood, power interruption, power surges, other “acts of God.”
- Liability/responsibility for damage to surrounding property, including but not limited to: cabinetry, floors, ceilings and other nearby structures/objects.
- Breakage/discoloration/damage to glass, metal surfaces, plastic components, trim, paint, or other cosmetic finish due to improper usage, care, abuse, or neglect.
- Discoloration or scratches of metal / stainless steel components.

OUT OF WARRANTY

- Should you experience a service issue beyond the standard warranty period, contact us anyway. RIAS reviews each issue and customer concern to provide the best possible solution under the circumstances.

THE REMEDIES PROVIDED IN THE ABOVE EXPRESS WARRANTIES ARE THE SOLE AND EXCLUSIVE REMEDIES. THUS, NO OTHER EXPRESS WARRANTIES ARE MADE, AND OUTSIDE THE 50 STATES OF THE UNITED STATES, THE DISTRICT OF COLUMBIA, AND CANADA, ALL IMPLIED WARRANTIES, INCLUDING BUT NOT LIMITED TO ANY IMPLIED WARRANTY OF MERCHANTABILITY OR FITNESS FOR A PARTICULAR USE OR PURPOSE, ARE LIMITED IN DURATION TO 3 YEARS FROM THE ORIGINAL PURCHASE DATE. IN NO EVENT SHALL RIAS BE LIABLE FOR INCIDENTAL EXPENSE OR CONSEQUENTIAL DAMAGES. IN THE EVENT RIAS PREVAILS IN ANY LAWSUIT, RIAS SHALL BE ENTITLED TO REIMBURSEMENT OF ALL COSTS AND EXPENSES, INCLUDING ATTORNEY'S FEES, FROM THE RIAS CUSTOMER. NO WARRANTIES, EXPRESS OR IMPLIED, ARE MADE TO ANY BUYER FOR RESALE.

Some states do not allow limitations on the length of an implied warranty, or do not allow the exclusion or limitation of inconsequential damages; therefore, the above limitations or exclusions may not apply to you. This warranty gives you specific legal rights, and you may also have other rights that vary from state to state.