

**New Cosmos USA, Inc.  
Natural Gas Alarm  
810NIT**

**User's Manual**

This manual has been prepared for the 810NIT Gas Alarm ("Gas Alarm"). If you have a Gas Alarm installed in your house or building, you should read and understand the important instructions and warnings contained in this manual and retain a copy for future reference.

When natural gas, which consists primarily of methane, is present at concentrations of 10% or greater of the lower explosive limit (LEL) for methane, the Gas Alarm is designed to activate a gas leak alarm. The gas leak alarm consists of a flashing red LED light, an audible warning sound (a loud beep), and a recorded message.

The Gas Alarm is equipped with an Itron Network Solutions (INS) communications module designed to automatically send information directly to your gas utility including information associated with gas leak alarm activation, Gas Alarm error, low battery, and end-of-service-life.

**⚠ DANGER: EXPLOSION, FIRE AND ASPHYXIATION**

Natural gas leak alarm indicates an emergency situation and risk of explosion.

- **EVACUATE IMMEDIATELY** and take others with you.
- **Do not use a phone, light a match, or turn on or off any light switches, flashlights, or appliances.** Doing so could **IGNITE a FIRE or EXPLOSION.**
- **CALL 911** once you are safely outside the premises.
- **Do not re-enter** until told to do so by authorities.

**⚠ DANGER: ELECTROCUTION**

- **Do not subject the Gas Alarm to water or liquid by submerging it, spraying liquid on it or otherwise.**
- **Do not disassemble.**

**⚠ DANGER: EXPLOSION**

**This Gas Alarm is designed to act as a continuous monitor of natural gas that reaches the sensor. This Gas Alarm should not be used as a short-term testing device to perform a onetime check for the presence of natural gas, as plugging the battery into the device in the presence of natural gas may cause an explosion.**

**⚠ DANGER: FIRE & EXPLOSION**

**Improper disposal may result in fire or explosion. Contact your gas utility to arrange for disposal.**

**⚠ DANGER: HAZARDOUS CONDITIONS**

**Follow these instructions completely. Failure to do so may result in an undetected natural gas leak or other hazardous conditions that may cause serious injury or death.**

**⚠ DANGER: HEARING DAMAGE**

**Do not place your ear directly against or in close proximity to the Gas Alarm when it is alarming. Such exposure to the audible gas leak alarm may damage your hearing.**

**⚠ WARNING**

- **Do not change the Gas Alarm's installation position, relocate it from where it is installed, or tamper with the Gas Alarm or its battery.**
- **Do not block, cover, obstruct or paint over the Gas Alarm or its sensor. The Gas Alarm can only detect natural gas that reaches its sensor.**

- **Network or power outages may prevent your gas utility from receiving or processing automated notifications from your Gas Alarm, including notifications related to gas leak alarms. Always follow these instructions, without relying on such automated notifications.**
- **This Gas Alarm will reach its end-of-service-life in approximately 10 years from the date of installation. Contact your gas utility for replacement if you observe the end-of-service-life alarm indicator LED.**
- **Do not modify, disassemble, submerge, strike, crush, or expose the Gas Alarm to high levels of volatile organic compounds. Doing so may cause the Gas Alarm to malfunction.**
- **Commercially available batteries will not work with the Gas Alarm. Contact your gas utility to arrange for replacement.**
- **Keep out of reach of children.**
- **For indoor use only.**

**⚠ NOTICE**

- **The Gas Alarm must only be installed by your gas utility or an authorized gas utility contractor.**
- **The Gas Alarm only detects natural gas. It does not detect carbon monoxide, fire, heat, smoke, flames, propane or any other gas.**
- **The Gas Alarm is not a substitute for proper installation, use, and maintenance of natural gas appliances and piping systems. The Gas Alarm does not prevent natural gas leaks from occurring, nor can it eliminate any existing natural gas leaks or problems.**

**General description & intended use**

**⚠ DANGER**

**If you smell natural gas, evacuate the area immediately, then call 911. Do not wait for the gas leak alarm to sound or for your gas utility to receive an automated notification.**

This Gas Alarm is designed to detect natural gas. Natural gas is a fossil fuel that is primarily made up of methane. It is commonly used for cooking, home heating and water heating. Natural gas is typically supplied through a gas main and utility service line connected to your home. Natural gas is odorless and colorless, but has a chemical odorant (mercaptan) added to it to give it a distinct "rotten eggs" smell. Even odorized natural gas may not be detected by smell in an unoccupied space, by an individual with reduced sensitivity to smell, or in other situations.

Natural gas is a highly flammable chemical compound. Although it happens rarely, a natural gas leak can occur inside a house or building. This can be dangerous because it increases risk of explosion and fire. The Gas Alarm is designed to activate a gas leak alarm when it detects 10% or greater of the LEL for methane, which is 0.5% or greater of methane in air. When the gas leak alarm activates, the Gas Alarm will beep 4 times and state "Danger - gas leak explosion risk - evacuate, then call 911." followed by 4 additional beeps and state "Peligro - riesgo de explosión por fuga de gas - evacuar, luego llamar al 911."

In the event of a gas leak, you may smell natural gas before the gas leak alarm is activated. If you smell natural gas at any time, do not wait for the gas leak alarm to sound or check for Gas Alarm malfunction. Evacuate immediately, then call 911.

Using the INS communications module, the Gas Alarm is designed to automatically send Gas Alarm-related information to your gas utility. When natural gas is detected at or above the gas leak alarm threshold, the Gas Alarm is designed to transmit a gas leak alarm notification to your gas utility. The Gas Alarm is also designed to send information about device health to your gas utility during automated health checks performed every 8 hours.

The Gas Alarm is not guaranteed to prevent personal injuries or property damage associated with a gas leak. For example, an error may occur that prevents detection of natural gas, including gas leaks. Network or power outages may prevent your gas utility from receiving or processing automated notifications from your Gas Alarm, including notifications related to gas leak alarms. Some people may sleep through and not hear the audible gas leak alarm. You should ensure that your natural gas appliances and piping systems are properly installed, used, and maintained to reduce the likelihood of a natural gas leak.

**Gas Alarm parts**

- **Green LED (Power)**  
This LED flashes when the test button is pressed.
- **Alarm speaker**  
Sounds an alarm when natural gas is present.
- **Red LED (Gas leak alarm)**  
This LED flashes when gas is detected.
- **Internal gas sensor**
- **Yellow LED (trouble)**  
This LED flashes when trouble occurs, when the battery is low, or when the end of service life has been reached.
- **Test button**

- **Production serial number label**

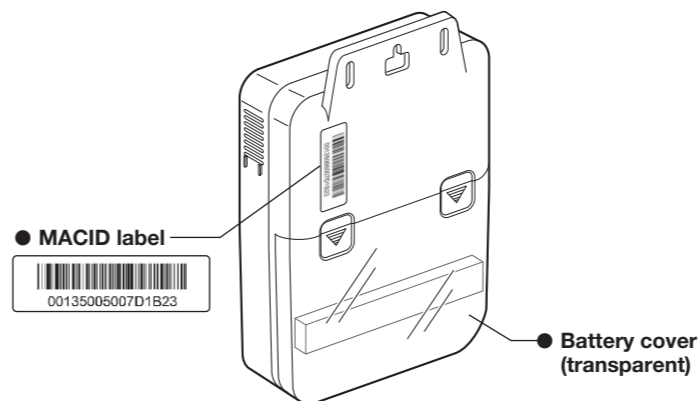

- **MACID label**



**Gas Alarm functions**

The Gas Alarm is designed to activate an audible gas leak alarm in the event of a natural gas leak, a Gas Alarm error, a low-battery condition, and when the Gas Alarm reaches its end-of-service-life. The INS communications module is also designed to send an automated notification to your gas utility when any of these alarms activate.

**Natural gas leak alarm activation**

The Gas Alarm is designed to activate a gas leak alarm when it detects natural gas at a concentration that reaches or exceeds 10% of the LEL for methane. When activated, the gas leak alarm is designed to:

**Beep 4 times and state "Danger – gas leak explosion risk – evacuate, then call 911." followed by 4 additional beeps and state "Peligro – riesgo de explosión por fuga de gas – evacuar, luego llamar al 911." This notification will repeat every 12 seconds for 4 minutes, and then every 1 minute thereafter. Send a gas leak alarm notification to your gas utility via the INS communications module every 30 seconds. Flash the Red LED light once every 2 seconds.**

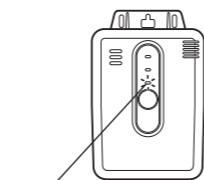

Red LED (gas leak alarm)  
Flashes once every 2 seconds

An alarm sounds every 12 seconds stating "Beep Beep Beep Beep Danger – gas leak explosion risk – evacuate, then call 911." followed by "Bip Bip Bip Peligro – riesgo de explosión por fuga de gas – evacuar, luego llamar al 911." Transmits gas leak alarm signals every 30 seconds.

**⚠ DANGER: EXPLOSION, FIRE AND ASPHYXIATION**

**Follow these instructions carefully in the event that the natural gas leak alarm activates. Never ignore any natural gas leak alarms. EVACUATE IMMEDIATELY and take others with you. Do not use a phone, light a match, or turn on or off any light switches, flashlights, or appliances. Doing so could IGNITE a FIRE or EXPLOSION. CALL 911 once you are safely outside the premises. Do not re-enter until told to do so by authorities.**

**⚠ DANGER: EXPLOSION RISK**

**Do not reset the Gas Alarm after gas leak alarm goes off, unless instructed to do so by emergency personnel. Resetting process can cause an explosion if conducted in an area with high concentrations of natural gas.**

Emergency responders or trained personnel may reset or instruct you to reset the Gas Alarm by removing and reinstalling the battery. After removing the battery, hold the test button for at least 10 seconds and leave the battery unplugged for at least 2 minutes. This will reset the device by turning off auditory and visual notifications.

**Error alarm activation**

An alarm indicates a Gas Alarm error by flashing the Yellow LED light (trouble) three times every 10 seconds, and an alarm will sound every 60 seconds, beep 3 times and state "Detector error" followed by 3 additional beeps and state "Error del detector". When this alarm activates, a Gas Alarm error notification is transmitted to your gas utility during the every-8-hour device health check.

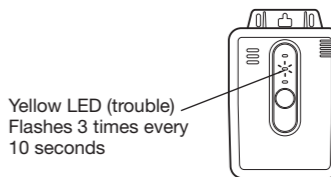

Yellow LED (trouble)  
Flashes 3 times every 10 seconds

Transmits Gas Alarm error notifications during the health checks performed every 8 hours.

**Low-battery alarm activation**

**⚠ NOTICE**

**Gas Alarm uses a specialized battery not available at retail. Contact your gas utility to arrange for replacement.**

An alarm sounds when the battery is low. When the low-battery alarm first activates, the Gas Alarm will beep 1 time and state "Low battery" followed by an additional beep and state "Batería baja". A low battery alarm will "Beep" every 60 seconds. Once every hour, the alarm will beep 1 time and state "Low Battery" followed by an additional beep and state "Batería baja."

By pressing the button for 3 seconds, an alarm will sound stating "Beep Low Battery" followed by "Bip Batería baja." If you observe the low-battery alarm indicator LED, contact your gas utility to arrange for replacement.

When this alarm activates, a low-battery notification is transmitted to your gas utility during the every-8-hour device health check.

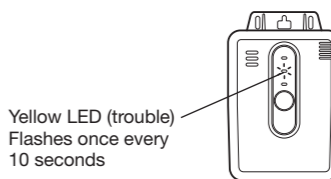

Yellow LED (trouble)  
Flashes once every 10 seconds

Initial transmission of the low battery payload occurs as soon as the battery voltage reaches the low battery threshold. Transmits a low battery notification during the health checks performed every 8 hours. The battery in this device is not available in retail. Contact your gas utility to arrange for replacement.

**End-of-service-life alarm activation**

An alarm sounds when the end of service life is reached. When the end-of-service-life alarm first activates, the Gas Alarm will beep 2 times and state "Please replace detector" followed by 2 additional beeps and state "Por favor, reemplace el detector."

An end of service life alarm will sound "Beep Beep" every 60 seconds. Once every hour, the alarm will state "Beep Beep Please replace detector" followed by "Bip Bip Por favor, reemplace el detector."

By pressing the button for 3 seconds, an alarm will sound stating "Beep Beep Please replace detector" followed by "Bip Bip Por favor, reemplace el detector." If you observe the end-of-service-life alarm indicator LED, contact your gas utility to arrange for replacement.

When this alarm activates, an end-of-service-life notification is transmitted to your gas utility during the every-8-hour device health check.

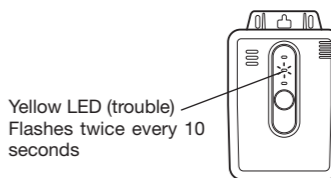

Yellow LED (trouble)  
Flashes twice every 10 seconds

Transmits an end-of-service-life notification during the health checks performed every 8 hours.

## Cleaning

### ⚠ WARNING

Dirt and dust can cause the Gas Alarm to malfunction. Follow these instructions to maintain proper operation.

If you observe dirt or dust accumulating on the Gas Alarm, contact your gas utility to arrange for the Gas Alarm to be cleaned. As an alternative, you can clean the Gas Alarm, as needed, by gently vacuuming the exterior of the unit including all slotted openings using a household vacuum's soft brush attachment.

Never use water, cleaners or solvents since they may damage the unit. Do not use spray cleaning chemicals, pesticides, or insect sprays directly on or near the Gas Alarm. Do not use any household cleaning agents, ammonia-based cleaners, paints, varnishes, aerosol sprays (including compressed gas dusters), or any other chemical on or near this Gas Alarm.

## Specifications

Detection principle	MEMS hot wire semiconductor sensor
Target gas	Methane gas (natural Gas)
Sensor immunity	Acetone, ethanol, bleach solution, among others
Operating temperature range	32°F (0°C) to 122°F (50°C)
Operating humidity range	5% to 95%, no condensation
Power supply	3V Lithium Battery
Alarm level	10% LEL
Sound Output	85 dB at 10 feet
Initial power-up timer	Approx. 30 seconds (green LED flashes once every second)
Weight and dimensions	Approx. 170g, W 85 x H 115 x D 28mm (excluding protrusions)
FCC Compliance	This device complies with Part 15 of the FCC Rules. Operation is subject to the following two conditions: (1) This device may not cause harmful interference and (2) this device must accept any interference received, including interference that may cause undesired operation.

## Contact Details

New Cosmos USA, Inc.  
650 Warrenville Rd, Suite 101  
Lisle, IL 60532  
Phone: (847) – 749 – 3064

## Troubleshooting Guide

This Gas Alarm is designed to be troubleshot exclusively by authorized professionals.

This guide is intended for professional use only.

## Testing the Gas Alarm

### ⚠ CAUTION

If the Gas Alarm does not operate properly, it cannot alert the presence of natural gas. Take immediate action if the Gas Alarm fails a test.

### Testing power

Press test button until you hear a “Beep” sound, then quickly release (within 10 seconds after pressing the test button). If the device is properly powered, the green LED will flash twice every second (for 3 seconds) to indicate that the power is on.

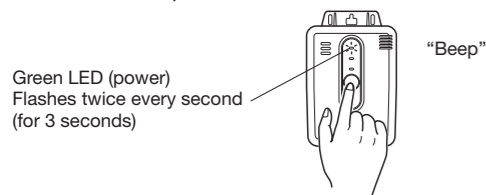

## Testing gas leak alarm notifications

Press test button until you hear a “Beep” sound, then continue to hold until you hear a “Beep Beep” sound approximately 10 seconds later. Release within 30 seconds of pressing the test button.

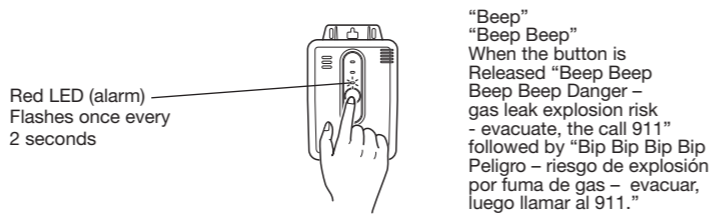

If the Gas Alarm is operating properly, the red LED will flash once every 2 seconds for a 12 second period, and the following alarm message will sound: “Beep Beep Beep Beep Danger – gas leak explosion risk – evacuate, then call 911.” followed by “Bip Bip Bip Bip Peligro – riesgo de explosión por fuma de gas – evacuar, luego llamar al 911.”

## Testing automated communications

Press and hold test button for at least 30 seconds, until you have heard a single “Beep” followed by a double beep (“Beep Beep”) followed by a triple beep (“Beep Beep Beep”). This will enable communications test mode, and the green LED will flash 3 times per second for as long as you are in communications test mode.

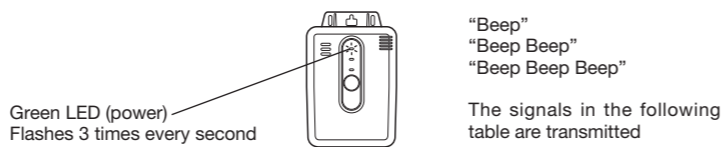

Once in communications test mode, press the test button additional times to test whether the Gas Alarm is communicating normally with your gas utility's systems, able to properly transmit Gas Alarm error signals, and able to properly transmit a low battery signal. Success will be indicated as follows:

	Green LED	Yellow LED
Communications test mode activated	Flashes 3x per second	Off
1st press: normal communication	Flashes 2x per second	Off
2nd press: proper transmission of device error signal	Flashes 2x per second	Flashes 3x per second
3rd press: proper transmission of low battery signal	Flashes 2x per second	Flashes 2x per second

If the red LED light activates or the alarm sounds during any of these tests, the Gas Alarm's communication functions are not working properly.

Additional presses will cycle you back through these three tests for as long as you are in communications test mode. Communications test mode will automatically end after 5 minutes.

## Troubleshooting

Symptom	Cause	Action
The green LED does not flash even when the switch is pressed	Battery connector not plugged in completely	Plug in the battery connector completely
	Battery is low	Replace the battery
The yellow LED is flashing 3 times every 10 seconds. After holding test button for an additional 3 seconds, yellow LED flashes twice.	Network connection error	Contact your gas utility
The yellow LED is flashing 3 times every 10 seconds. After holding test button for an additional 3 seconds, yellow LED flashes 3 times.	Device error unrelated to network connection	Replace the Gas Alarm
The yellow LED is flashing.	Flashes once every 10 seconds: Low battery	Replace the battery
	Flashes twice every 10 seconds: End of service life	Replace the Gas Alarm

## Professional Installation Guide

This Gas Alarm is designed to be installed and cleaned exclusively by authorized professionals. Users should not install or clean the gas alarm themselves.

This guide is intended for professional use only.

## Selecting location for installation

### ⚠ NOTICE

- Installation in an improper location can affect the sensitive electronic components in Gas Alarm.
- Improper placement can prevent detection of methane.
- Place out of reach of children.

Gas Alarm should be installed by attaching it to a pipe or, if a suitable pipe is unavailable, to a location on a wall that is:

- Within 12 inches (0.3 meters) from the ceiling.
- In an area where it will not be impeded by items hanging from or near the ceiling such as curtains, drapes, ceiling fans.
- At least 3 feet (0.9 meters) from cooking appliance or cooktop hood, no more than 10 feet (3 meters) away.
- At least 3 feet (0.9 meters) from gas appliances, no more than 10 feet (3 meters) away.

Product should **NOT** be installed:

- In the peak of a cathedral ceiling.
- Directly above or near sources of water or humidity such as a sink, cooktop, dishwasher or shower.
- Next to a door or window.
- Next to a ventilation fan.
- Near a room return or HVAC duct.
- In an area where the temperature will drop below 32°F (0°C) or exceed 122°F (50°C).
- In an area that is dusty or dirty.
- In an area where organic solvents exist or silicone vapors exist.
- In a damp or very humid location, such as a bathroom.
- Outside.

## Installing the battery

### ⚠ DANGER – SHOCK

Do not remove the plastic wrap surrounding the battery pack. Doing so may cause electrical short or shock.

### ⚠ NOTICE

Gas Alarm uses type of battery that is not available in retail. Contact your gas utility if replacement battery needed.

After installing battery, test the Gas Alarm following instructions in Troubleshooting Guide.

To reinstall the included battery or install a new battery you received from your gas utility:

- Open the battery cover on the back of the Gas Alarm. This cover slides out of place. To open, place both thumbs on the back of the battery cover where the battery cover hooks snap into place.
- Push down where the battery cover snaps into place with your thumbs and slide the cover out. Some force is required.

To remove the battery cover, push down at the indicated points with your thumbs and slide the cover in the direction of the arrow.

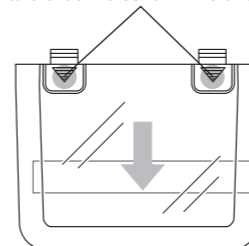

- Connect the included lithium battery by inserting the battery harness connector into the Gas Alarm as shown in the diagram below. Do not remove the plastic wrap surrounding the battery pack.

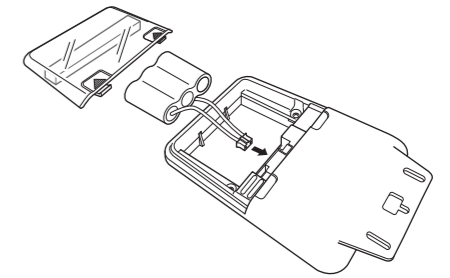

- The battery connector has a large notch on it that faces up when installed correctly. There is only one way in which the connector can be installed. A small portion of the connector will be exposed when connected properly.

## Mounting the Gas Alarm

### ⚠ NOTICE

After mounting the Gas Alarm, test it following instructions in Troubleshooting Guide.

If possible, mount the Gas Alarm to a pipe meeting the criteria discussed in the “Selecting location for installation” section.

To mount to a pipe:

- Pass a cable tie through the hole at the top of the Gas Alarm.

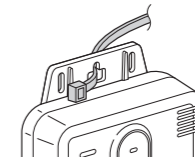

- Wrap the cable tie around the pipe and tie off.

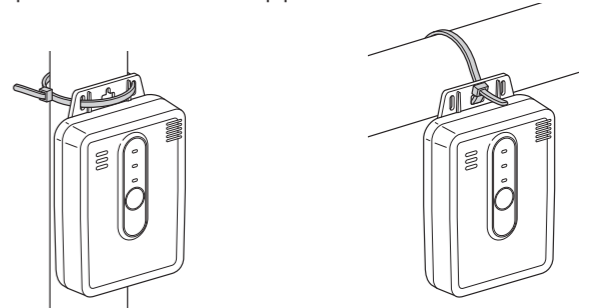

If mounting to a pipe is not feasible, mount the Gas Alarm to a wall.

- Choose a location on the wall within 12 inches (0.3 meters) from the ceiling. Make a mark in the Mounting Tab of the Gas Alarm where you will drill the mounting hole.
- Use a 3/16” (5 mm) drill bit to drill the mounting hole and insert included anchor.
- Tighten the screw into the anchor until the screwhead is about 3/16 inch (5 mm) away from the wall, leaving enough space for the Mounting Tab.
- Hang the Mounting Tab on the screw.

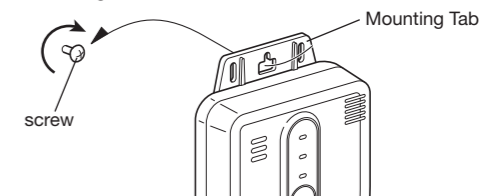

- Lightly tighten the screw to secure the Gas Alarm.