

cilicon⁺

EMPOWER CANNABIS COMMUNITY WITH DIVERSE AND
INNOVATIVE VAPING DEVICES

www.ciliconplus.com

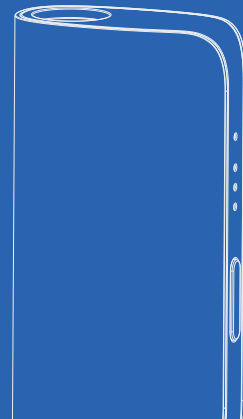

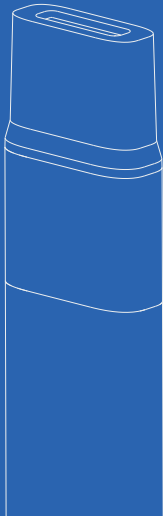
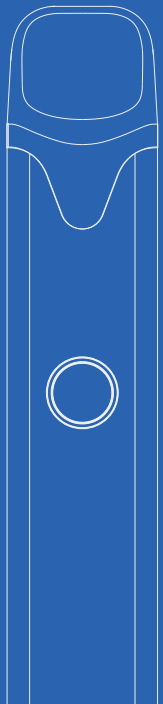

DEFINING AND UPGRADING CANNABIS VAPORIZATION

CILICON is established with one dream to be fully committed and improve the daily lives of our clients through our innovative vaping technology. We are equipped with world-class facilities to develop a comprehensive cannabis vape entity with efficient technology and product R&D, high-quality manufacturing, and competent customer service.

Amid the "Bad Money Drives Out Good" market dilemma, many low-quality counterfeit products circulating in the market. Those products are claimed to be harmful to our clients. Therefore, CILICON takes extra precautions to combat such a dilemma. We have integrated our comprehensive value chain system to establish a phenomenal professional cannabis vape solution platform. CILICON DESIGNED, is tailored to reduce customer investment of time and capital. Our brand aims to differentiate and specify our clients' demands by providing exclusive premium products to all cannabis companies.

At CILICON, we provide professional cannabis vape solutions to our driven international clients through innovative technology and a wide variety of products. We always welcome our clients and help them to increase their brand competitiveness. CILICON will never compromise on the quality and safety of our products. We always prioritize our customer satisfaction while we are dedicated to becoming the world's most iconic cannabis vape device provider. The success of your brand is our topmost priority.



A GLANCE ON CILICON

200,000+sq.ft

Manufacturing Base

20 million per month

Production Capacity

700+

Patents

1,500+

Served More Than 1500 Customers

35

Covered 35 Countries

4,000+

Have More Than 4000 Employees



OUR ADVANTAGES

01

ON TIME, UNDER BUDGET



02

YEARS OF MANUFACTURING EXPERIENCE



03

ALL-AROUND TECHNOLOGICAL SUPPORT

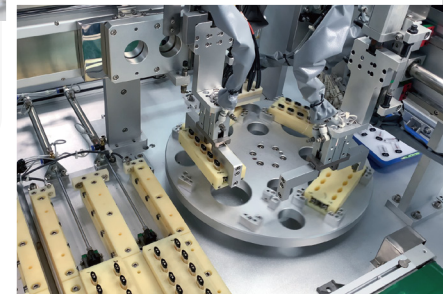
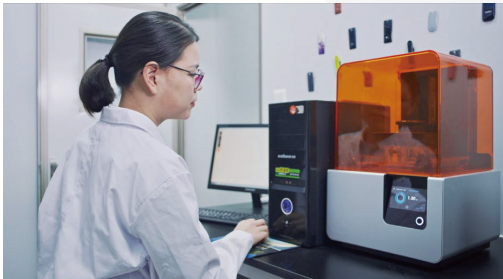

04

NOT JUST A MANUFACTURER, BUT ALSO A PROFESSIONAL SOLUTION SUPPLIER.



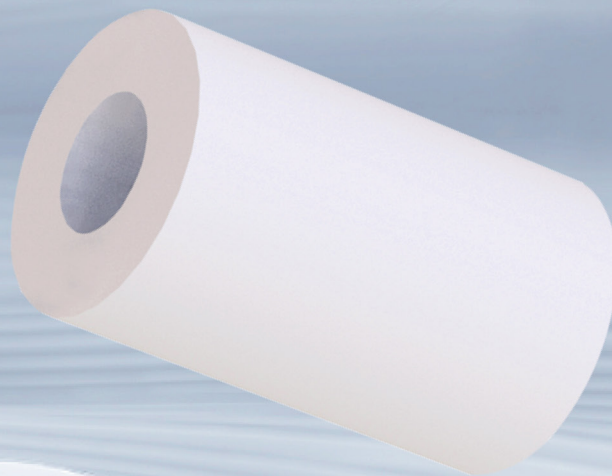

SAFE & SUPERIOR VAPING EXPERIENCE DRIVEN BY FORMATRIX™

We employ pure, durable, high-quality raw ceramics and industry-leading patent ceramic heating technology – Formatrix™ to produce a brand-new heating engine, that allows users to consume cannabis oil with superior and safe vaping experience.

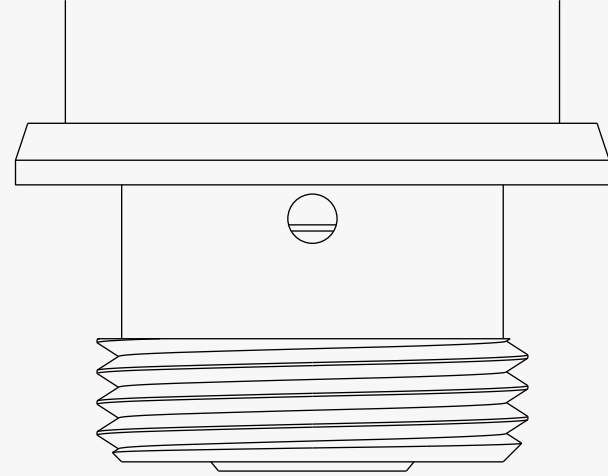

510 CARTRIDGE

A 510-thread cartridge is the most common type of vape cartridge. "510" refers to 10 threads at 5mm, describes the type of threading that is used to screw the bottom of the cartridge to the appropriate vape battery.

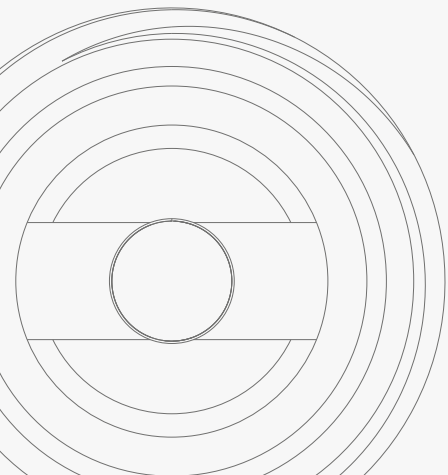

ELEV Nano1

More Joy with Less Cost



Glass Oil Tank

- High Corrosion Resistant



Spacfill™ Technology

- Increase Filling Efficiency



Formatrix™ Technology

- The New Generation of Ceramic Heating Technology

Specifications:

Dimension:	Φ14.0*48.0mm (1.5mL) Φ14.0*54.5mm (2.0mL)
Tank Volume:	1.5mL/2.0mL
Tank Material:	Glass
Central Post:	SUSL316 Stainless Steel
Mouthpiece:	Food Grade PC
Tip Type:	Press In
Ceramic Coil:	Formatrix™ Ceramic Heating Coil
Connection:	Universal 510 Thread Power Supply

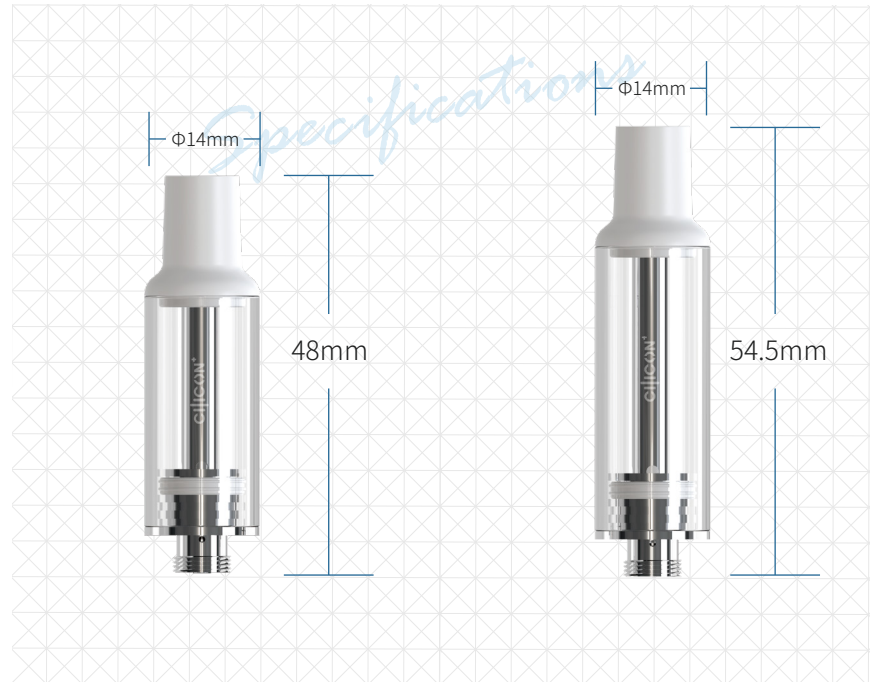

ELEV Nano2

Cartridges for More Reliable and Premium Experiences



Ceramic Mouthpiece

- Safe and Quality



Formatrix™ Technology

- The New Generation of Ceramic Heating Technology



Glass Oil Tank

- High Corrosion Resistant

Specifications:

Dimension:	Φ11.0*52.3mm (0.5mL) Φ11.0*64.6mm (1.0mL)
Tank Volume:	0.5mL/1.0mL
Tank Material:	Glass
Mouthpiece:	Ceramic
Tip Type:	Screw In
Ceramic Coil:	Formatrix™ Ceramic Heating Coil
Connection:	Universal 510 Thread Power Supply

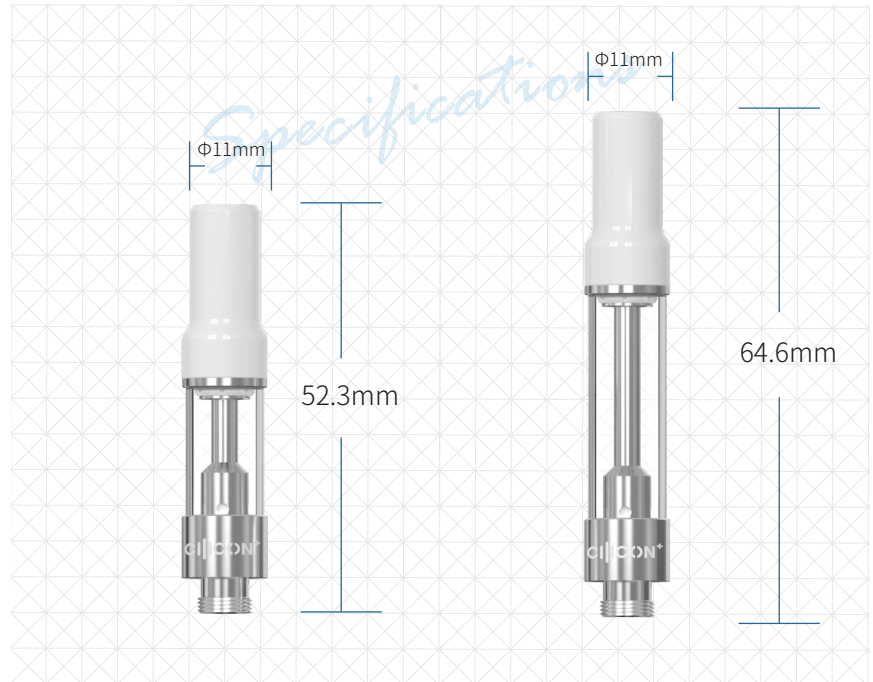

SOLO Nano1

The Best for Less

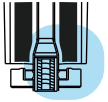

Oil Isolation Technology

- Solve 99% of Leaking Problem
- Maintain Extra Terpenes



More Space for Customization

- Including But Not Limited to Color or Material Design



Microfeel Technology®

- Extraordinary Ceramic Heating Technology

Specifications:

Dimension:	11.0*52.8mm (0.5mL) 11.0*63.6mm (1.0mL)
Tank Volume:	0.5mL/1.0mL
Coil Material:	Microfeel® Ceramic Coil
Tank Material:	Food Grade PCTG
Central Post:	316 Stainless Steel
Mouthpiece Material:	Food Grade PCTG
Tip Type:	Press In



SOLO Nano2

Mash The Stereotype by All New Technology



Oil Isolation Technology

- Solve 99% of Leaking Problem
- Maintain Extra Terpenes



More Space for Customization

- Different Color Fit with Different Terpene Flavor



Formatrix™ Technology

- The New Generation of Ceramic Heating Technology

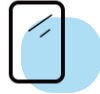

Glass Oil Tank

- High Corrosion Resistant

Specifications:

Dimension:	Ø11.0*56.2mm
Tank Volume:	1.0mL
Coil Material:	Formatrix™ Ceramic Coil
Central Post:	316 Stainless Steel
Mouthpiece Material:	Food Grade PCTG
Tank Material:	Glass
Tip Type:	Press In



SOLO Nano3

Breakthrough Design, Smaller but Better



Oil Isolation Technology

- Solve 99% of Leaking Problem
- Maintain Extra Terpenes



More Space for Customization

- Including But Not Limited to Color or Material Design



Formatrix™ Technology

- The New Generation of Ceramic Heating Technology

Specifications:

Dimension:	Ø11.0*46.3mm
Tank Volume:	1.0mL
Coil Material:	Formatrix™ Ceramic Coil
Central Post:	316 Stainless Steel
Mouthpiece Material:	Food Grade PP
Tank Material:	Glass/Food Grade PCTG
Tip Type:	Press In



LONG BATTERY LIFETIME & STEADY PRODUCT PERFORMANCE

How to prolong the life-time of the battery and raise the charge efficiency? Cilicon employs pure LiCoO₂ battery with high quality and designs a steady product structure to ensure an excellent performance of battery, that allows for the safeness in vaping.



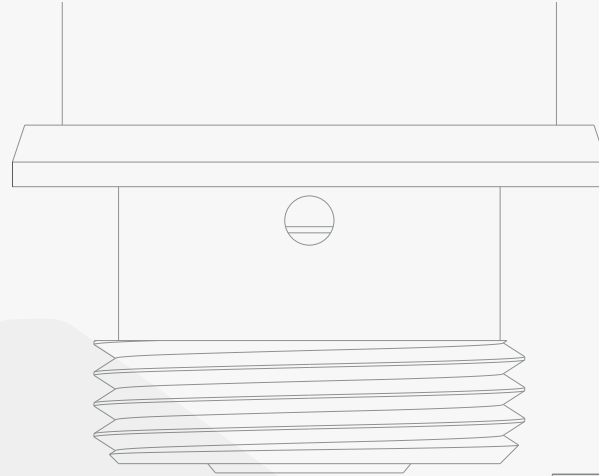

BATTERY

Batteries work with 510 Cartridges. The vape battery will power an atomizer in the cartridge that heats up the oil, be activating the vaping journey.



ELEV Buff1

Make a Change for Your Flavor Consistency



316L Stainless Steel Housing



2 Voltage Settings

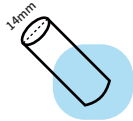

14mm Diameter Connection

Specifications:

Dimension:	Φ14.0*76.0mm
Battery Capacity:	400mAh
Output Power:	8.2W/3.5V (Standard) 5.2W/2.8V (Lower)
Charging:	Micro USB
Battery Housing:	SUS304 Stainless Steel
Connection:	Universal 510 Thread Power Supply

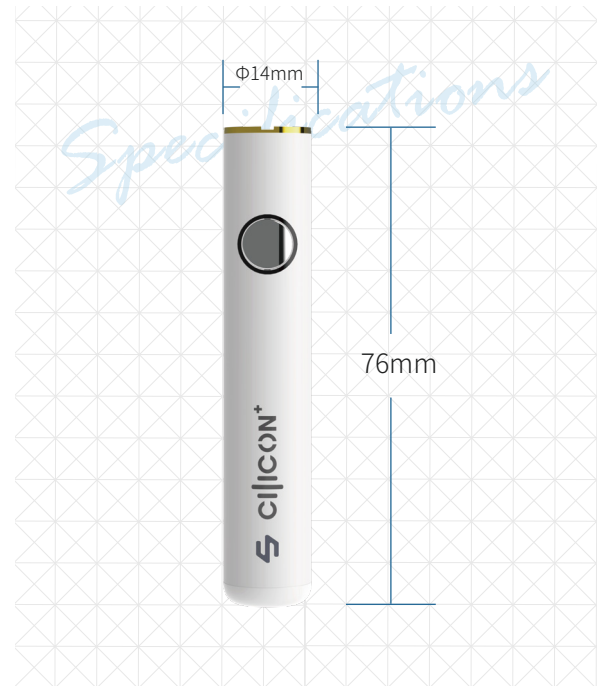

LIT Buff2

An affordable premium vape experience

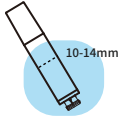

Compatible with 10mm-14mm 510 Cartridge

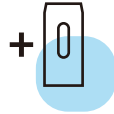

Magnet Connection Cartridge Cover Protection



Intelligent Temperature Control



3 Voltage Settings

Specifications:

Dimension:	Φ14.0*113.6mm
Battery Capacity:	290mAh
Output Power:	3.8W/2.4V (Standard) 5.2W/2.8V (Medium) 6.8W/3.2V (High)
Charging:	Type C
Battery Housing:	AL6063
Button Material:	Metal
Connection:	Universal 510 Thread Power Supply



EDGE Mod1

Illuminating the Industry



Temperature Controlled



Dose Control



Magnetic Connection



Vision Window

Specifications



Specifications:

Dimension:	65.1*34.4*18.0mm
Battery Capacity:	600mAh
Voltage:	3.8V, 3.3V, 2.8V
Activation:	Button/Breath Actuated
Material:	Aluminium Alloy
Charging:	Type-C USB

EDGE Buff1

Have a Seat and Spark it Up



Temperature Controlled



Pocket Size



Uneasy to Break

Specifications:

Dimension:	Φ12.5*82.74mm
Battery Capacity:	320mAh
Voltage:	3.8V,3.3V,2.8V
Charging:	Micro USB





THE ANSWER TO HOW COME CILICON TAKES 39.8% OF DISPOSABLE MARKET SHARE

The more recognizable and stylish industrial design embodies the unique aesthetic value of Cilicon, that leads the fashion trend in the industry. In addition, the superior product stability brought by more sophisticated structure allows for more high-received value for brand-building.

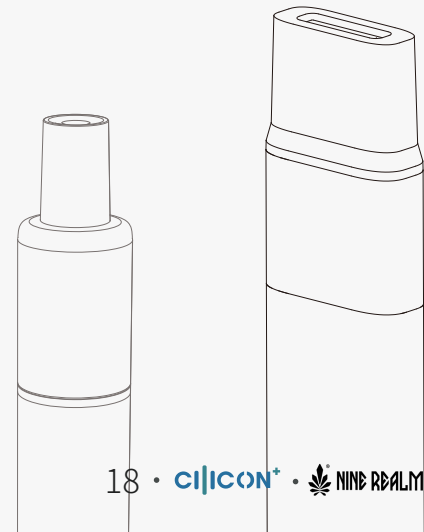

DISPOSABLE

Disposable contains a pre-charged battery designed to support the device until the cart empties. They contain no threading and are not meant to be separated from their battery, and meant to be disposed of after use.



GLIST Air1

Push Up for Your Portable Experience



Duair™ Technology

- Anti-Oil Clogging



BioBaleen™ Module

- Reducing Spit-Back by 99%



Formatrix™ Technology

- The New Generation of Ceramic Heating Technology

Specifications:

Dimension:	20.59*13.91*91.56mm
Tank Volume:	0.5mL
Battery Capacity:	270mAh
Tank Material:	Food Grade Plastic (PCTG)
Mouthpiece Material:	PC
Ceramic Coil:	Formatrix™ Ceramic Heating Coil
Central Post:	Stainless Steel (SUS316L)
Activation:	Breath Actuated
Charging:	Micro USB
Tip Type:	Snap In



SOLO 1

The Genius Combination of Disposable & Rechargeable



BioBaleen™ Module

- Reducing Spit-Back by 99%



Formatrix™ Technology

- The New Generation of Ceramic Heating Technology

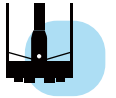

Vshaped™ Oil Tank

- Every Drop of Concentrate Will Be Consumed

Specifications:

Dimension:	19.1*8.1*92.0mm (0.5mL) 19.1*8.1*105.0mm (1.0mL)
Tank Volume:	0.5mL/1.0mL
Battery Capacity:	280mAh
Tank Material:	Food Grade Plastic (PCTG)
Central Post:	Stainless Steel (SUS316L)
Activation:	Breath Actuated
Ceramic Coil:	Microfeel® Ceramic Heating Coil
Charging:	Micro USB

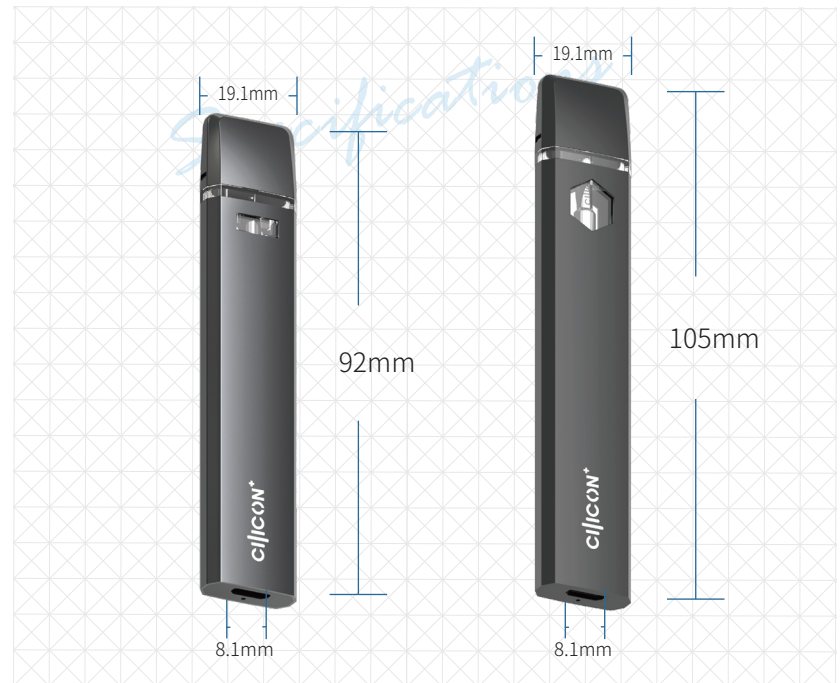

SOLO 1 Pro

Pro Your View, Pro Your Experience



BioBaleen™ Module

- Reducing Spit-Back by 99%



Panoramic Glassy Window

- Revealing When Others Hide



Formatrix™ Technology

- The New Generation of Ceramic Heating Technology

Specifications:

Dimension:	19.1*8.1*108.8mm
Tank Volume:	1.0mL
Battery Capacity:	280mAh
Tank Material:	Food Grade PCTG
Mouthpiece Material:	Food Grade PC
Central Post:	316 Stainless Steel
Coil Material:	Formatrix™ Ceramic Coil
Charging:	Micro USB
Battery Housing:	Aluminum Alloy



SOLO 2

Upgrade More Than the Capacity

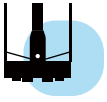

Vshaped™ Oil Tank

- Every Drop of Concentrate Will Be Consumed



BioBaleen™ Module

- Reducing Spit-Back by 99%



Duair™ Technology

- Anti-Oil Clogging



Formatrix™ Technology

- The New Generation of Ceramic Heating Technology

Specifications:

Dimension:	21.6*9.1*113.5mm (without button) 21.6*9.1*116.8mm (with button)
Tank Volume:	2.0mL
Battery Capacity:	270mAh
Tank Material:	Food Grade Plastic (PCTG)
Mouthpiece Material:	Food Grade Plastic (PCTG)
Central Post:	Stainless Steel (SUS316L)
Activation:	Breath/Button Actuated
Ceramic Coil:	Formatrix™ Ceramic Heating Coil
Charging:	Micro USB



SOLO 2

Upgrade More Than the Capacity

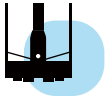

Vshaped™ Oil Tank

- Every Drop of Concentrate Will Be Consumed



Formatrix™ Technology

- The New Generation of Ceramic Heating Technology



BioBaleen™ Module

- Reducing Spit-Back by 99%



Duair™ Technology

- Anti-Oil Clogging

Specifications:

Dimension:	22.1*10.3*110.0mm
Tank Volume:	3.0mL
Battery Capacity:	280mAh
Tank Material:	Food Grade PCTG
Mouthpiece Material:	Food Grade PCTG
Central Post:	316 Stainless Steel
Activation:	Inhale Activated
Coil Material:	Formatrix™ Ceramic Coil
Charging:	Micro USB
Battery Housing:	Aluminum Alloy
Tip Type:	Snap In



ELEV Bar1

Elevate The Notion of Tradition



Spacexfill™ Technology

- Extended Oil-Injecting Space for Effectiveness



Formatrix™ Technology

- The New Generation of Ceramic Heating Technology

Specifications:

Dimension:	Φ14.0*88.3mm (0.5mL) Φ14.0*95.1mm (1.0mL)
Tank Volume:	0.5mL/1.0mL
Battery Capacity:	400mAh
Tank Material:	Glass
Mouthpiece Material:	Food Grade PP
Central Post:	316 Stainless Steel
Activation:	Inhale Activated
Coil Material:	Formatrix™ Ceramic Coil
Charging:	Micro USB (1mL only)
Battery Housing:	Stainless Steel
Tip Type:	Press In



ELEV Bar1

Elevate The Notion of Tradition



Spacexfill™ Technology

- Extended Oil-Injecting Space for Effectiveness



Formatrix™ Technology

- The New Generation of Ceramic Heating Technology

Specifications:

Dimension:	Φ14.0*101.5mm (1.5mL) Φ14.0*108.0mm (2.0mL)
Tank Volume:	1.5mL/2.0mL
Battery Capacity:	400mAh
Tank Material:	Glass
Mouthpiece Material:	Food Grade PP
Central Post:	316 Stainless Steel
Activation:	Inhale Activated
Coil Material:	Formatrix™ Ceramic Coil
Charging:	Micro USB
Battery Housing:	Stainless Steel
Tip Type:	Press In

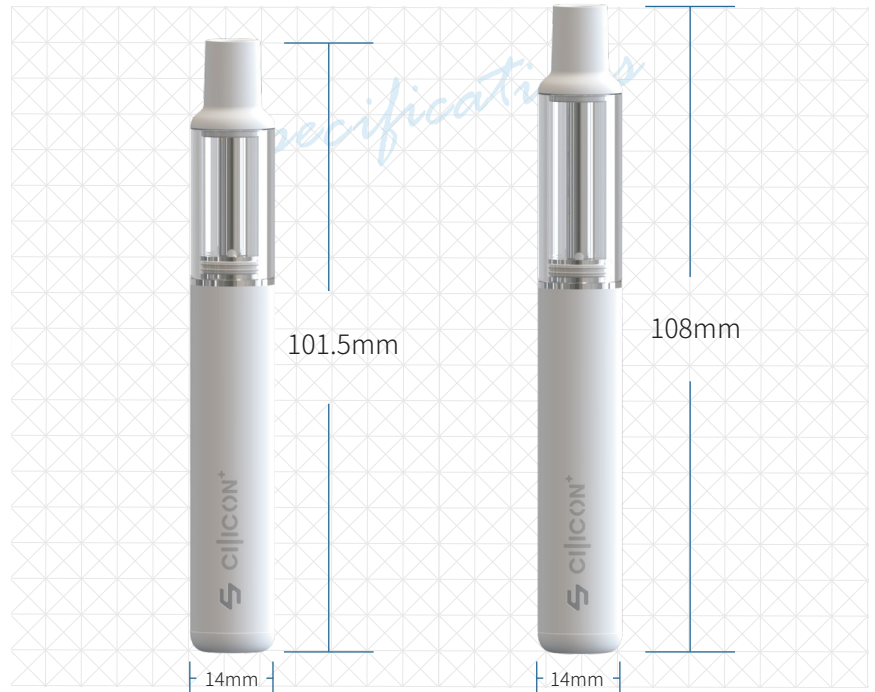

ELEV Bar1

Elevate The Notion of Tradition



Spacexfill™ Technology

- Extended Oil-Injecting Space for Effectiveness



Formatrix™ Technology

- The New Generation of Ceramic Heating Technology

Specifications:

Dimension:	Φ14.0*125.0mm
Tank Volume:	3.0mL
Battery Capacity:	400mAh
Tank Material:	Glass
Mouthpiece Material:	Food Grade PP
Central Post:	316 Stainless Steel
Activation:	Inhale Activated
Coil Material:	Formatrix™ Ceramic Coil
Charging:	Micro USB
Battery Housing:	Stainless Steel
Tip Type:	Press In



EDGE 1

Larger Capacity, Greater Design



BioBaleen™ Module

- Reducing Spit-Back by 99%

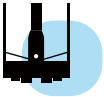

Vshaped™ Oil Tank

- Every Drop of Concentrate Will Be Consumed



Formatrix™ Technology

- The New Generation of Ceramic Heating Technology

Specifications:

Dimension:	22.0*9.5*118.0mm
Tank Volume:	2.0mL
Battery Capacity:	270mAh
Tank Material:	Food Grade Plastic (PCTG)
Mouthpiece Material:	PC
Battery Housing:	Aluminum Alloy
Central Post:	316 Stainless Steel
Charging:	Micro USB



ELEV Air2

The Search for Balance Between High Volume and Steady Performance

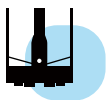

Vshaped™ Oil Tank

- Every Drop of Concentrate Will Be Consumed



BioBaleen™ Module

- Reducing Spit-Back by 99%



Duair™ Technology

- Anti-Oil Clogging



Formatrix™ Technology

- The New Generation of Ceramic Heating Technology

Specifications:

Dimension:	24.1*14.1*112.0mm
Tank Volume:	3mL
Battery Capacity:	270mAh
Tank Material:	Food Grade Plastic (PCTG)
Mouthpiece Material:	PC
Central Post:	Stainless Steel (SUS316)
Battery:	First Layer: PC; Second Layer: ABS
Activation:	Breath Actuated
Ceramic Coil:	Formatrix™ Ceramic Heating Coil
Charging:	Micro USB
Tip Type:	Snap In



ELEV Box1

Increased Storage, Uncompromised Performance



Vshaped™ Oil Tank

- Every Drop of Concentrate Will Be Consumed



BioBaleen™ Module

- Reducing Spit-Back by 99%



Duair™ Technology

- Anti-Oil Clogging



Formatrix™ Technology

- The New Generation of Ceramic Heating Technology

Specifications:

Dimension:	35.5*11.0*81.0mm
Tank Volume:	2mL
Battery Capacity:	280mAh
Tank Material:	Food Grade Plastic (PCTG)
Mouthpiece Material:	PC
Central Post:	Stainless Steel (SUS316)
Activation:	Breath Actuated
Ceramic Coil:	Formatrix™ Ceramic Heating Coil
Charging:	Micro USB



EDGE Box1

More Than Just a Chic and Traceless Look



Vshaped™ Oil Tank

- Every Drop of Concentrate Will Be Consumed



BioBaleen™ Module

- Reducing Spit-Back by 99%



Duair™ Technology

- Anti-Oil Clogging



Formatrix™ Technology

- The New Generation of Ceramic Heating Technology

Specifications:

Dimension:	35.0*19.5*81.3mm
Tank Volume:	2mL
Battery Capacity:	270mAh
Tank Material:	Food Grade Plastic (PCTG)
Mouthpiece Material:	PC
Central Post:	Stainless Steel (SUS316)
Activation:	Breath Actuated
Ceramic Coil:	Formatrix™ Ceramic Heating Coil
Charging:	Micro USB

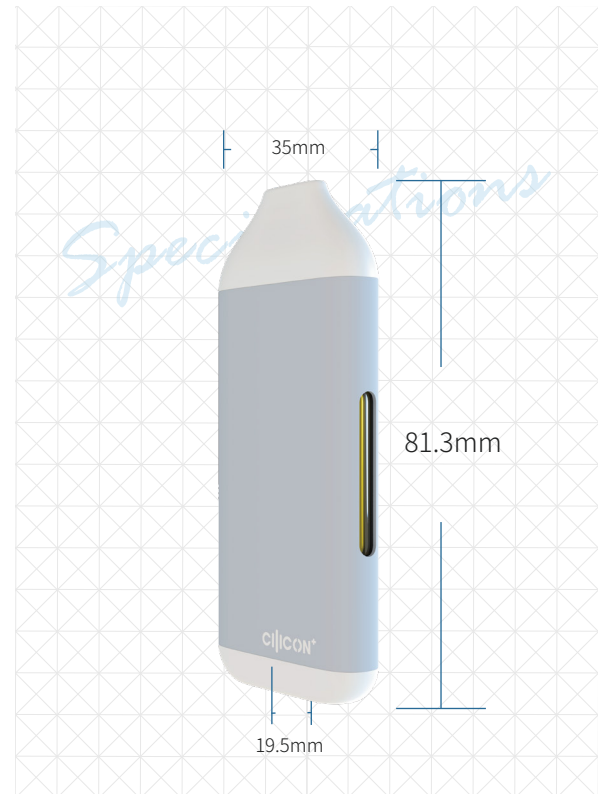

FLARE 1

Every Vapor Is a Gentle last



Microfeel Technology®

- Extraordinary Ceramic Heating Technology



Child Resistant Lock

- Prevent Children from Accidents



Vshaped™ Oil Tank

- Every Drop of Concentrate Will Be Consumed

Specifications:

Dimension:	19.67*8.98*109.05mm
Tank Volume:	1.0mL
Battery Capacity:	270mAh
Tank Material:	Food Grade PCTG
Central Post:	316 Stainless Steel
Activation:	Button Activated
Coil Material:	Microfeel® Ceramic Coil
Charging:	Micro USB
Battery Housing:	Aluminum Alloy
Mouthpiece Material:	Food Grade PC
Tip Type:	Snap In



ELEV 1

Elevate Notions of Purity



BioBaleen™ Module

- Reducing Spit-Back by 99%



Formatrix™ Technology

- The New Generation of Ceramic Heating Technology

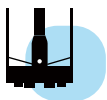

Vshaped™ Oil Tank

- Every Drop of Concentrate Will Be Consumed

Specifications:

Dimension:	19.4*8.3*106.0mm (without button) 19.4*8.3*109.0mm (with button)
Tank Volume:	1.0mL
Battery Capacity:	280mAh
Tank Material:	Food Grade PCTG
Mouthpiece Material:	Food Grade PC
Central Post:	316 Stainless Steel
Coil Material:	Formatrix™ Ceramic Coil
Charging:	Micro USB
Battery Housing:	Aluminum Alloy
Activation:	Inhale/Button Activated
Tip Type:	Snap In



EDGE Air1

Slip from the lightness to the greatness



Vshaped™ Oil Tank

- Every Drop of Concentrate Will Be Consumed



BioBaleen™ Module

- Reducing Spit-Back by 99%

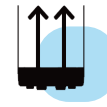

Duair™ Technology

- Anti-Oil Clogging



Formatrix™ Technology

- The New Generation of Ceramic Heating Technology

Specifications:

Dimension:	20.5*10.1*109.0mm
Tank Volume:	1.0mL
Battery Capacity:	280mAh
Tank Material:	Food Grade Plastic
Mouthpiece Material:	PC
Battery Housing:	Plastic
Ceramic Coil:	Matrex™ Ceramic Heating Coil
Central Post:	Stainless Steel (SUS316L)
Activation:	Breath Actuated
Charging:	Micro USB

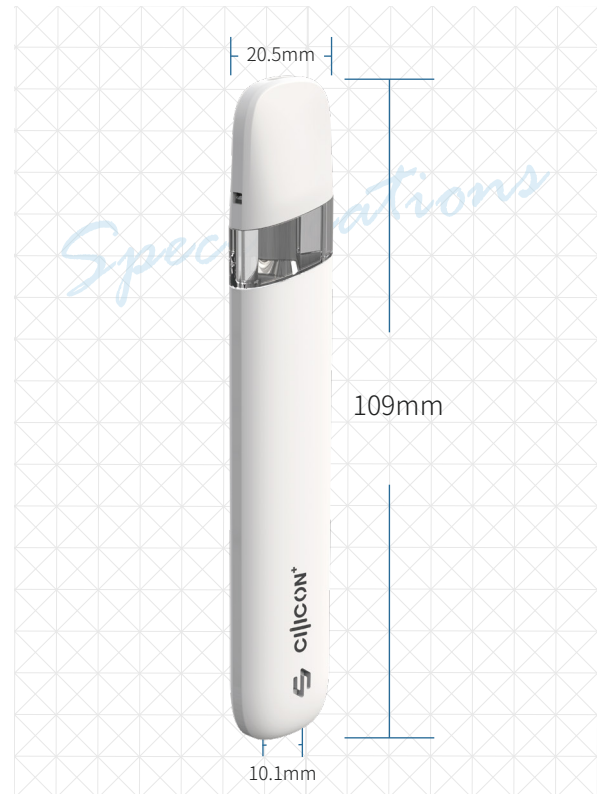

ELEV Air1

Silky-Smooth From the Inside Out



Vshaped™ Oil Tank

- Every Drop of Concentrate Will Be Consumed



Formatrix™ Technology

- The New Generation of Ceramic Heating Technology



BioBaleen™ Module

- Reducing Spit-Back by 99%



Duair™ Technology

- Anti-Oil Clogging

Specifications:

Dimension:	20.5*19.5*104.5mm
Tank Volume:	1.0mL
Battery Capacity:	270mAh
Tank Material:	Food Grade Plastic
Mouthpiece Material:	PC
Central Post:	Stainless Steel (SUS316L)
Charging:	Micro USB
Ceramic Coil:	Formatrix™ Ceramic Heating Coil
Battery Housing:	Plastic



LIT 1

The Most Reliable Child-Resistant Disposable on the Market



Microfeel Technology®

- Extraordinary Ceramic Heating Technology



Child Resistant Lock

- Prevent Children from Accidents



Oil Isolation Technology

- Solve 99% of Leaking Problem Maintain Extra Terpenes

Specifications:

Dimension:	Φ11.4*111.0mm
Tank Volume:	0.5mL
Battery Capacity:	335mAh
Tank Material:	Food Grade PCTG
Central Post:	316 Stainless Steel
Activation:	Inhale Activated
Coil Material:	Microfeel® Ceramic Coil
Charging:	Micro USB
Battery Housing:	314 Stainless Steel
Mouthpiece Material:	Food Grade PCTG
Tip Type:	Press In



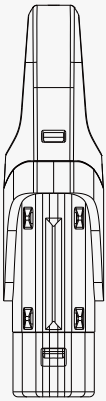

SMALL POD BIG EXPERT



Combining a variety of brand-new technologies, we design a multi-functional and top-class pod system. Excelling in preserving the authentic aroma of your terpene profile and delivering maximum potency, it is a truly marvelous creation by a group of proud pioneers.

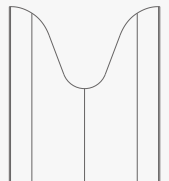
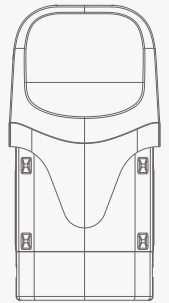

POD



POD SYSTEM

Pod System contains a battery housing unit that is rechargeable and meant to be kept by the user, and a “pod” that is filled with concentrate and can be easily dropped into the battery housing unit in order to vape. Once the “pod” is empty, the user simply removes and swaps in a brand new fully filled pod.

FLARE X1

Exclusive Experience, Excellent Exploration



Duair™ Technology

- Anti-Oil Clogging



Oil Isolation Technology

- Solve 99% of Leaking Problem Maintain Extra Terpenes



Formatrix™ Technology

- The New Generation of Ceramic Heating Technology

Specifications:

Dimension:	20.1*10.1*110.0mm
Tank Volume:	1.0mL
Battery Capacity:	280mAh
Tank Material:	Food Grade Plastic (PCTG)
Central Post:	Stainless Steel (SUS316L)
Battery Housing:	Aluminum Alloy (AL6063)
Mouthpiece:	Material: PC



FLARE X1 Pro

Exclusive Experience, Excellent Exploration



Duair™ Technology

- Anti-Oil Clogging



Oil Isolation Technology

- Solve 99% of Leaking Problem Maintain Extra Terpenes



Matching Wireless Base Charger

Specifications:

Dimension:	20.1*10.1*115.5mm
Tank Volume:	1.0mL
Battery Capacity:	300mAh
Tank Material:	Food Grade Plastic (PCTG)
Central Post:	Stainless Steel (SUS316L)
Battery Housing:	Aluminum Alloy (AL6063)
Mouthpiece Material:	PC
Tip Type:	Snap In



FLARE X2

Offering Extraordinary Flavor Payoff, You'd Expect



Microfeel Technology®

- Extraordinary Ceramic Heating Technology



Oil Isolation Technology

- Solve 99% of Leaking Problem Maintain Extra Terpenes



10 Mins Auto Off

- Power Saving, Protect Children

Specifications:

Dimension:	111.2*19.9*9.9mm
Tank Volume:	1.0mL
Battery Capacity:	300mAh
Tank Material:	Food Grade PCTG
Central Post:	316 Stainless Steel
Activation:	Button/Breathe Activated
Coil Material:	Microfeel® Ceramic Coil
Charging:	Micro USB
Battery Housing:	Aluminum Alloy
Mouthpiece Material:	Food Grade PC
Tip Type:	Snap In



