

# Installation and Maintenance Manual

MRRW-E

## Radial<sup>®</sup> Electric Winch 60 Rewind<sup>™</sup>

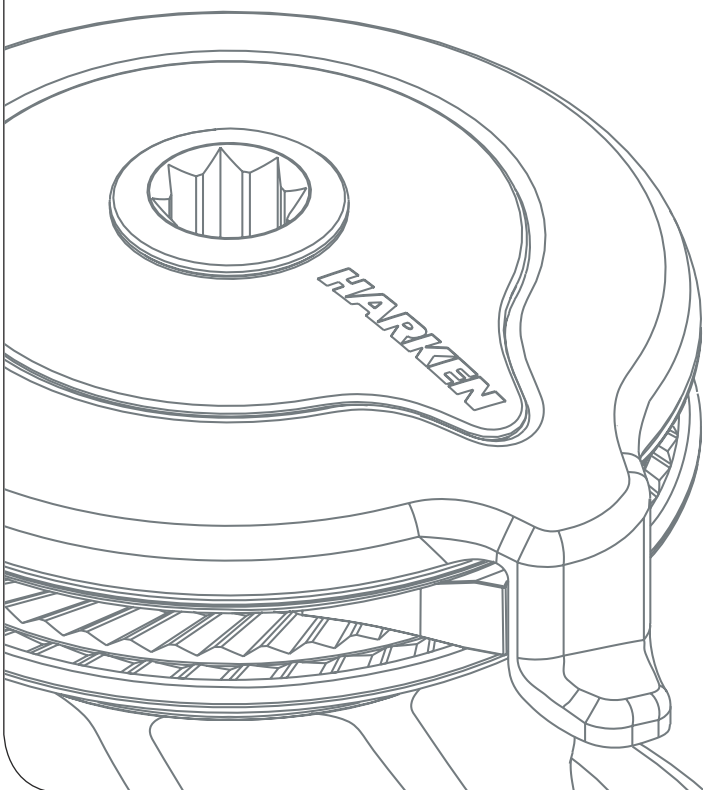

**HARKEN<sup>®</sup>**

<b>Introduction</b>	<b>3</b>
<b>Technical characteristics</b>	<b>3</b>
<i>Performance data</i>	3
<i>Weight</i>	3
<i>Maximum working load</i>	4
<b>Outline</b>	<b>4</b>
<i>Radial® 60 Rewind™</i>	4
<i>Horizontal electric motor</i>	4
<b>Installation</b>	<b>4</b>
<i>Winch installation procedure</i>	6
<i>Winch drilling cut-out</i>	8
<i>Positioning the self-tailing arm</i>	8
<b>Motor installation procedure</b>	<b>10</b>
<i>Electric equipment</i>	11
<b>Maintenance</b>	<b>13</b>
<i>Washing</i>	13
<i>Maintenance table</i>	13
<i>Disassembly procedure</i>	13
<i>Exploded view with maintenance products</i>	16
<i>Assembly</i>	17
<b>Harken® limited worldwide warranty</b>	<b>18</b>
<b>Ordering spare parts</b>	<b>18</b>
<b>Exploded view</b>	<b>19</b>
<b>Parts List</b>	<b>21</b>
<i>Winch 60 Rewind™ STA EL</i>	21
<i>Winch 60 Rewind™ STC EL</i>	22
<i>Winch 60 Rewind™ STCW EL</i>	23
<i>Winch 60 Rewind™ STBBB EL</i>	24
<i>Winch 60 Rewind™ STCCC EL</i>	25
<i>Horizontal electric motor 12V/24V</i>	26

## Introduction

This manual gives technical information on winch installation and maintenance, including disassembling and reassembling.

This information is DESTINED EXCLUSIVELY for specialised personnel or expert users.

Installation, disassembling and reassembling of the winch by personnel who are not experts may cause serious damage to users and those in the vicinity of the winch.

Harken® accepts no responsibility for defective installation or reassembly of its winches.

In case of doubt the Harken® Tech Service is at your disposal at [techservice@harken.it](mailto:techservice@harken.it)

This Manual is available only in English. If you do not fully understand the English language, do not carry out the operations described in this Manual.

## NOTICE

To use and understand this manual, user must refer to other documents, available on web site [www.harken.com](http://www.harken.com) and listed below:

- The Dual Function Control Box user manual, for the use of the Dual Function Control Box.
- The Dual Function Control Box installation manual, for all details, informations, wiring schemes and warnings about its installation

## Technical characteristics

	Power ratio	Gear ratio
1st speed	20,30 : 1	4,80 : 1
2nd speed	61,00 : 1	14,41 : 1

*The theoretical power ratio does not take friction into account.*

### Performance data

#### 60 Rewind™ Winch

	horizontal motor		horizontal motor	
	12 V (1500 W)		24 V (2000 W)	
	1st speed	2nd speed	1st speed	2nd speed
line speed (m/min)**	17,7	5,9	17,7	5,9
max load (Kg)	600	1800	600	1800

*\*\*Line speed is measured with no load*

		motor nominal power (W)		current absorption at winch MWL (A)	
		12 V	24 V	12 V	24 V
		60 Rewind™ Winch	horizontal	1500	2000

## Weight

	ST A	ST C/CW	ST BBB/CCC
weight (Kg)	22	26	27,3

### Versions:

A = drum in anodised aluminium

C = drum in chrome bronze

CW = chrome/white

BBB = all bronze

CCC = All-Chrome bronze

## Maximum working load



### WARNING!

The maximum working load (MWL) for the 60 Rewind™ Winch is 1800 Kg (3968 lb).

Subjecting the winch to loads above the maximum working load can cause the winch to fail or pull off the deck suddenly and unexpectedly during high loads causing severe injury or death.

## Outline

60 Rewind™ Winch

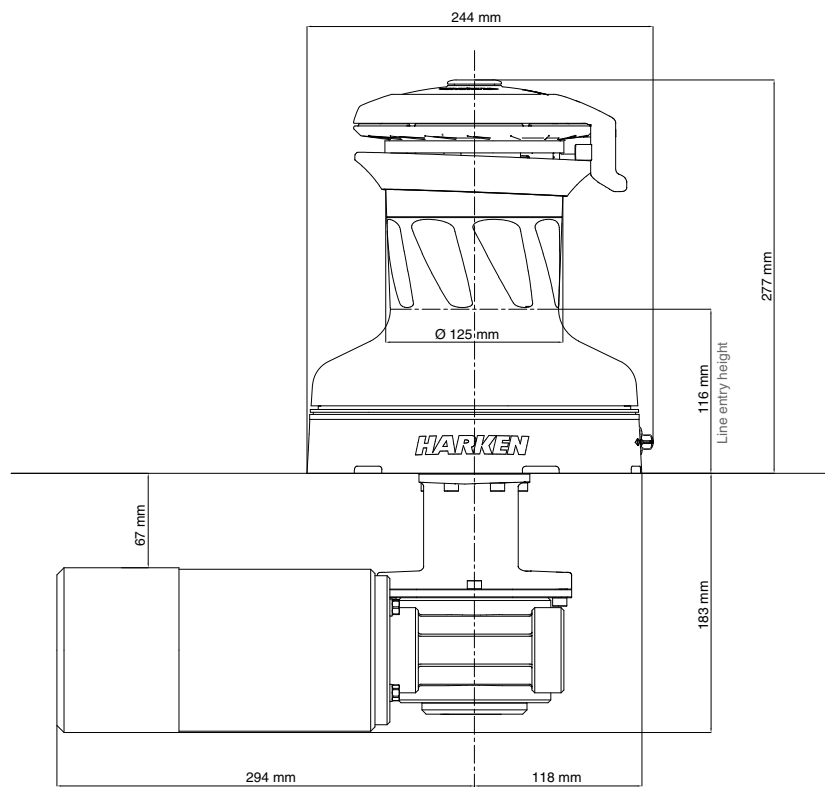

## Installation

The winch must be installed on a flat area of the deck, reinforced if necessary to bear a load equal to at least twice the maximum working load of the winch.

It is the installer's responsibility to carry out all structural tests needed to ensure that the deck can bear the load.

Harken® does not supply the screws needed to install the winch since these may vary depending on the deck on which it is to be installed.

It is the installer's responsibility to choose the correct screws taking account of the loads they will have to bear.

Harken® assumes no responsibility for incorrect installation of its winches or for an incorrect choice of mounting screws.



### **DANGER!**

Incorrect installation of the winch may cause severe injury or death. Consult the yard that built the boat in the case of doubt over the correct positioning of the winch.



### **WARNING!**

Failure to use the correct number and type of mounting fasteners or failure to ensure the correct deck strength can result in the winch pulling off the deck suddenly and unexpectedly during high loads causing severe injury or death.



### **WARNING!**

Verify the entry angle of the sheet. This must be  $8^\circ$  with tolerance of  $\pm 2^\circ$ , to avoid sheet overrides and damaging the winch or making the winch inoperable leading to loss of control of the boat which can lead to severe injury or death.



### **WARNING!**

Mount the winch on the deck so that the final drive gear is positioned where the sheet enters the winch drum. Incorrect position of drive gear can weaken winch leading to failure which can cause an accident leading to severe injury or death.

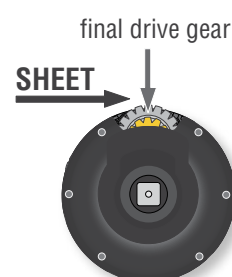
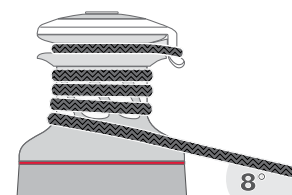

After correctly positioning the final drive gear with respect to the load, check that the motor, gearing, electrical wiring and/or hydraulic pipes can be housed below decks. To help find the optimal compromise, remember that, to make the installation of the motor easier, it can be coupled to the winch in different positions.

Once you have decided the correct mounting position for the winch on the deck and checked the space available below deck, proceed with the installation.

The winch can be installed following the two procedure below (**Winch installation procedure**).

**Before starting the Installation procedure, set the knob in the following position:**

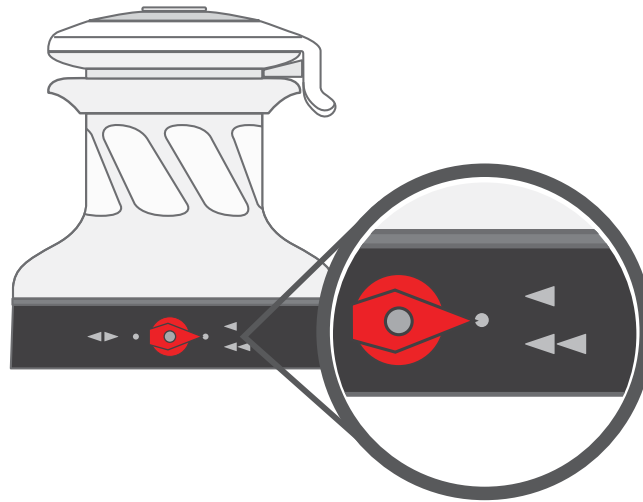

### Winch installation procedure

To install the winch, remove the drum and use Socket Head (SH) bolts.

#### Tools needed

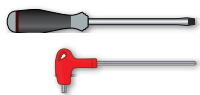

One medium flat-bladed screwdriver

A number 5 hex key

A number 6 hex key

A number 3 hex key

To identify the various parts, refer to the exploded view at the end of this Manual.

 Torque to apply when assembling



1. Pull out the disconnect rod n°21



2. Unscrew the central screw ( $\approx 2\text{Nm}/18\text{ in-lb}$ )



3. Slide off the assy socket n°35 and the cover n°19.  
Pay attention to the o-ring in the socket.



4. Unscrew the three screws n°41  
( $\approx 4\text{Nm}/35\text{ in-lb}$ )



5. Remove the stripper arm n°44 by rotating and lifting it.



6. Lift off the drum n°20

Install the winch on the deck in the position you have chosen, keeping in mind the limits described on page 4 and using socket head (SH) bolts.

*Follow steps below only to install the winch using hexagonal headed bolts*



7. Unscrew the 6 hex screws n°14  
( 20Nm/177 in-lb)



8. Lift off the spacer n°38



9. Remove the assy drum support n°13

Install the winch on the deck in the position you have chosen, keeping in mind the limits described on page 4 and using hexagonal headed (HH) M8 bolts.



### Winch drilling cut-out

#### **NOTICE**

Before drilling the deck, check the space available below deck for the flange and the motor

- A.** Position the base of the winch on the deck and mark the position of the holes or use the drilling cut-out template at the point where you have decided to place the winch.

Below is a reduced scale diagram.

The drilling cut out template is available on the Harken® website, [www.harken.com](http://www.harken.com)

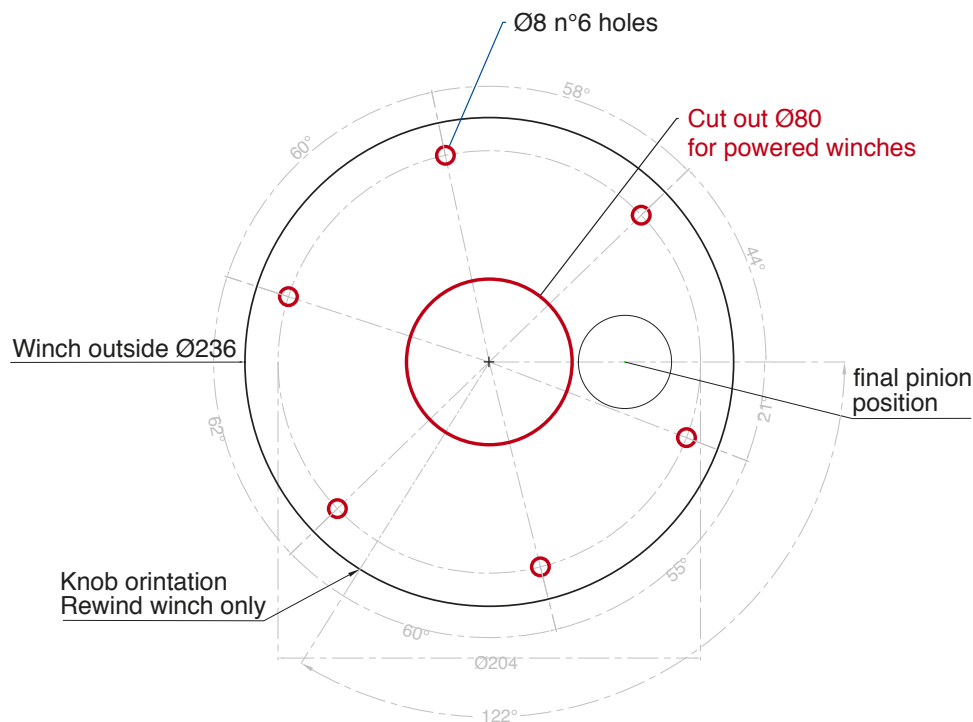

- B.** Remove the winch and drill the six 8.5 mm diameter holes.
- C.** Bolt the base of the winch to the deck using six M8 Socket Head (SH) bolts for Winch installation procedure (not supplied by Harken®), correctly chosen for the thickness and type of the boat deck. Consult the yard that built the boat in case of doubt.



#### **WARNING!**

To install the winch on the deck, use only bolts in A4 stainless steel (DIN 267 part11). Bolts made of other materials may not have sufficient strength or may corrode which can result in winch pulling off deck suddenly and unexpectedly during high loads causing severe injury or death.

#### **NOTICE**

To mount winches on the deck, do not use countersunk bolts.

- D.** Fill the mounting holes with a suitable marine sealant.
- E.** Remove the excess adhesive/sealant from the holes and base drainage channels
- F.** Reassemble the winch following the steps in **Winch installation procedure** in the reverse order, and apply the products indicated in the section on maintenance.

### Positioning the self-tailing arm

Position the self-tailing arm so that the line leaving the winch is led into the cockpit.

## Motor installation procedure

Once you have installed the winch on the deck, proceed with motor installation. The motor can be coupled to the winch in different positions. Check the space available below deck and choose the suitable position.

### Tools needed

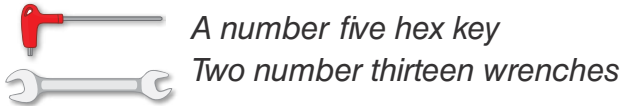

1. Position the flange (see Page 12)



2. Tighten six M6 precote coated screws (8 Nm/ 71 in-lb)



3. Position the reduction gear and motor



4. Tighten the two screws (8 Nm/ 71in-lb). Be sure to align the flange.

**NOTICE**

Before positioning the flange, check to make sure that seal is seated correctly.



After winch is assembled and before sailing, test the powered winch functioning.

Electric equipment

To guarantee greater efficiency in terms of safety and long life, for every winch model is mandatory to install the Dual Function Control Box.

*To fasten the Dual Function Control Box containing solenoids to bulkhead or wall, for all installation details and for all electric wiring schemes, refer to the Dual Function Control Box manual.*



**WARNING!**

Before installing and using the device, read carefully the Dual Function Control Box manual available on web site [www.harken.com](http://www.harken.com)

Refer to the following chart for wire size:

*Total distance between winch and battery*

Winch size	Current voltage	Under 16.4 ft AWG	Under 5 m mm <sup>2</sup>	16.4 - 32.8 ft AWG	5 m - 10 m mm <sup>2</sup>	32.8 - 49.2 ft AWG	10 m - 15 m mm <sup>2</sup>	49.2 - 65.6 ft AGW	15m - 20 m mm <sup>2</sup>
60 Rewind™	12 V	2	32	0	50	00	70	000	95
60 Rewind™	24 V	5	16	3	25	2	35	0	50

Refer to the following chart for HCP model:

Winch size	Current voltage	HCP model	Ampere rating
60 Rewind™	12 V	HCP1720	135A
60 Rewind™	24 V	HCP1717	80A

**NOTICE**

To connect motor, attach cable terminals to clamps between nut and lock nut. Hold nut in contact with motor using a spanner and tighten other nut with second spanner. Take special care not to turn the central spindles. These instructions apply when assembling and disassembling. We recommend using a torque wrench so as to obtain a torque equal to and no greater than 10 Nm (88 in-lb).

**NOTICE**

Note that correct electrical contact sequence is:  
Nut – Cable Terminal – Self-Locking Washer – Lock Nut



## Maintenance

### Washing

Winches must be washed frequently with fresh water, and in any case after each use. Do not allow teak cleaning products or other cleaners containing caustic solutions to come into contact with winches and especially anodised, chrome plated or plastic parts. Do not use solvents, polishes or abrasive pastes on the logos or stickers on the winches. Make sure that the holes and drainage channels in the base of the winch are not obstructed so that water does not collect.

### Maintenance table

Winches must be visually inspected at the beginning and end of every season of sailing or racing. In addition they must be completely overhauled, cleaned and lubricated at least every 12 months. After an inspection, replace worn or damaged components. Do not replace or modify any part of the winch with a part that is not original.



#### **WARNING!**

Periodic maintenance must be carried out regularly. Lack of adequate maintenance shortens the life of the winch, can cause serious injury and also invalidate the winch warranty. Installation and maintenance of winches must be carried out exclusively by specialized personnel.

In the case of doubt contact Harken® Tech Service at [techservice@harken.it](mailto:techservice@harken.it)







#### **WARNING!**

Make sure that the power is switched off before installing or carrying out maintenance on the winch.

### Winch disassembly procedure

#### *Tools needed*

-  One medium flat-bladed screwdriver
-  A number five and six hex key
-  Brush
-  Rags

To identify the various parts refer to the exploded view at the end of this Manual.

 Torque to be applied in assembly phase

Carry out **Winch Installation Procedure** as shown in the paragraph on winch installation and then do the following:



7. Unscrew the 6 hex screws n°14  
( 20Nm/177 in-lb)



8. Lift off the spacer n°38



9. Remove the assy drum support n°13



10. Slide out the central shaft n°24 and pay attention to the two balls n°26



11. Remove the idler and pinion n°11 and slide out the two roller bearing n°12



12. Remove the pawls carrier gear n°8 and slide out the 2 roller bearings n°9



13. Remove the ratchet gear n°7



If it is necessary to replace any **jaws** of the winch, proceed as follows:



I. Unscrew the 4 screws n°39  
( $\approx 4\text{Nm}/35\text{ in-lb}$ )



II. Remove the jaws n°43

Inspect balls inside the drum and carefully check the correct position; if it is necessary to put back any balls, push balls in the race (as shown below):



Once the winch is completely disassembled, clean the parts with a degreasing that does not leave residues, proper to clean metal components; rinse plastic parts in fresh water. Once you have done this, dry the parts with cloths that do not leave residue.

Inspect gears, bearings, pins and pawls for any signs of wear or corrosion.

Carefully check the teeth of gears and ring gears to make sure there are no traces of wear.

Check the roller bearings and check there are no breaks in the bearing cages.

Replace worn or damaged components.

Carry out maintenance on components using the products listed below.

For more information on which products to use where, refer to the exploded diagram below.

Use a brush to lightly lubricate all gears, gear pins, teeth and all moving parts with grease.

Lightly lubricate the pawls and springs with oil. Do not use grease on the pawls!

Winch exploded view with maintenance products

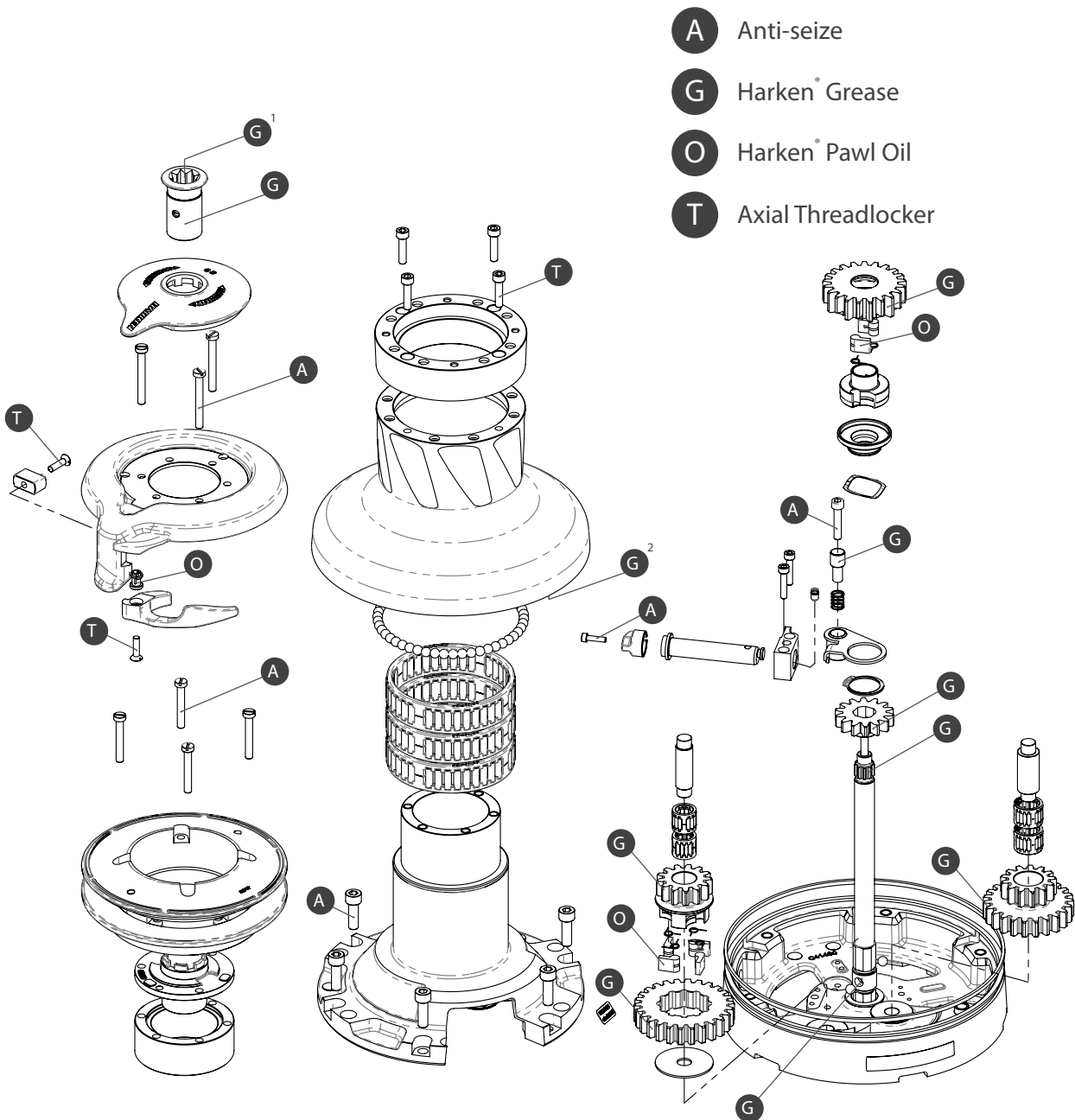

- A** Anti-seize
- G** Harken® Grease
- O** Harken® Pawl Oil
- T** Axial Threadlocker

Apply Harken® grease where indicated above  
 Apply Harken® grease: 1. on assy socket screw - 2. on drum gear

**NOTICE**

On every gear and every component that must be greased, apply Harken® grease with a brush in a proper quantity as shown below:



**NOTICE**

Harken® grease to apply on all teeth: do not use excessive quantity of product to void wastes. If in contact with the pawls, an excess of grease can compromise the safety of the winch.



Winch assembly

Make sure that the holes and drainage channels in the base of the winch are not obstructed  
 Assemble the winch in the reverse order of the sequence in the section on disassembly.

To tighten bolts, use the torque indicated in the disassembly procedure.

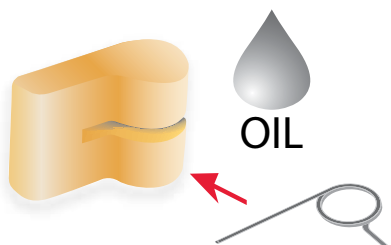

**To assemble the pawls:**

correctly position the spring in its housing as shown at left. Hold the spring closed and slide the pawl into its housing. Once in position, check that the pawls can be easily opened and closed with a finger.

**NOTICE!** Before closing the winch, make sure the holes and drainage channels in the base of the winch are not obstructed.

**NOTICE!** Before screw the central screw, check the correct position of the o-ring in the assy socket and apply Harken® grease.

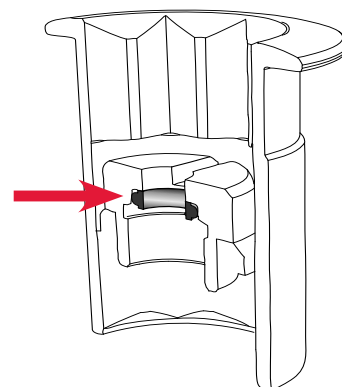

**NOTICE!** Insert the disconnect rod in the winch, with the groove in the lower part of the rod.

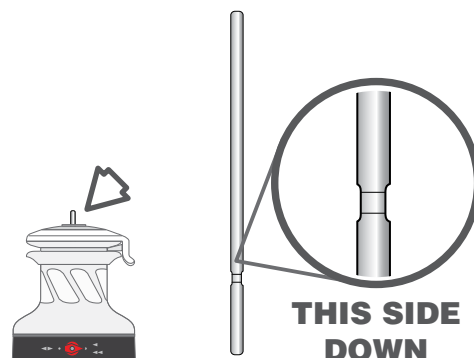

In case of doubt concerning the assembly procedure contact Harken® Tech Service: [techservice@harken.it](mailto:techservice@harken.it)

**Harken® limited worldwide warranty**

Refer to the Harken® Limited Worldwide Warranty in the Harken® Catalogue and on the website [www.harken.com](http://www.harken.com)

**Ordering spare parts**

Spare parts can be requested from Harken® as described in the Harken® Limited Worldwide Warranty, indicating the part number in the Parts List and including the serial number of the winch for which the parts are required.

***The serial number of the winch is printed on a plate on the drum support of the winch.***



**Manufacturer**

**Harken® Italy S.p.A.**

Via Marco Biagi, 14  
 22070 Limido Comasco (CO) Italy  
 Tel: (+39) 031.3523511  
 Fax: (+39) 031.3520031  
 Email: [info@harken.it](mailto:info@harken.it)  
 Web: [www.harken.com](http://www.harken.com)

- **Tech Service**  
 Email: [techservice@harken.it](mailto:techservice@harken.it)
- **Customer Service**  
 Tel: (+39) 031.3523511  
 Email: [info@harken.it](mailto:info@harken.it)

**Headquarters**

**Harken®, Inc.**

1251 East Wisconsin Avenue  
 Pewaukee, Wisconsin 53072-3755 USA  
 Tel: (262) 691.3320  
 Fax: (262) 691.3008  
 Email: [harken@harken.com](mailto:harken@harken.com)  
 Web: [www.harken.com](http://www.harken.com)

- **Tech Service**  
 Email: [technicalservice@harken.com](mailto:technicalservice@harken.com)
- **Customer Service**  
 Tel: (262) 691-3320  
 Email: [customerservice@harken.com](mailto:customerservice@harken.com)

**Exploded view**

Winch 60 Rewind STA, STC, STCW, STBBB, STCCC EL

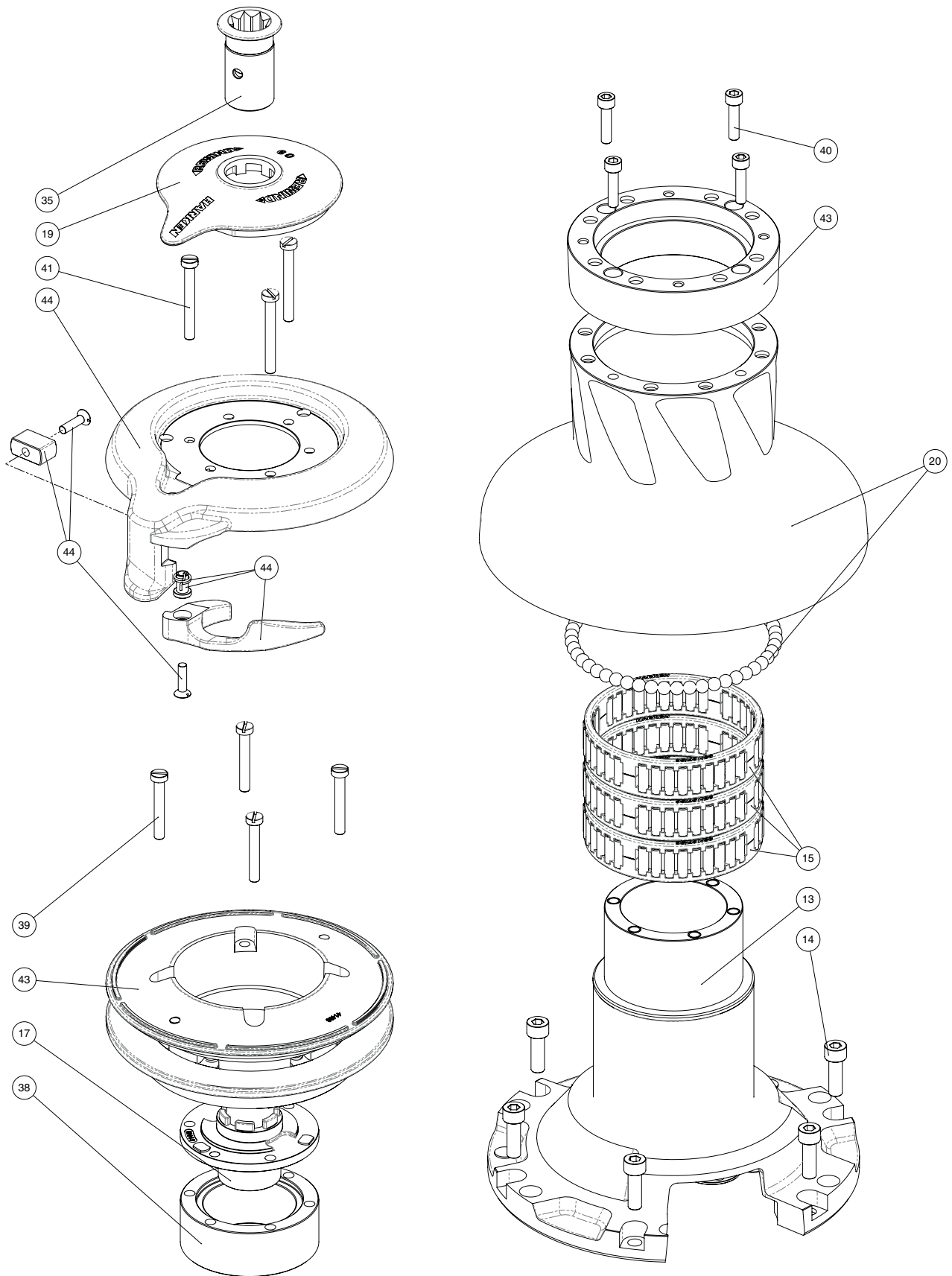

Winch 60 Rewind STA, STC, STCW, STBBB, STCCC EL

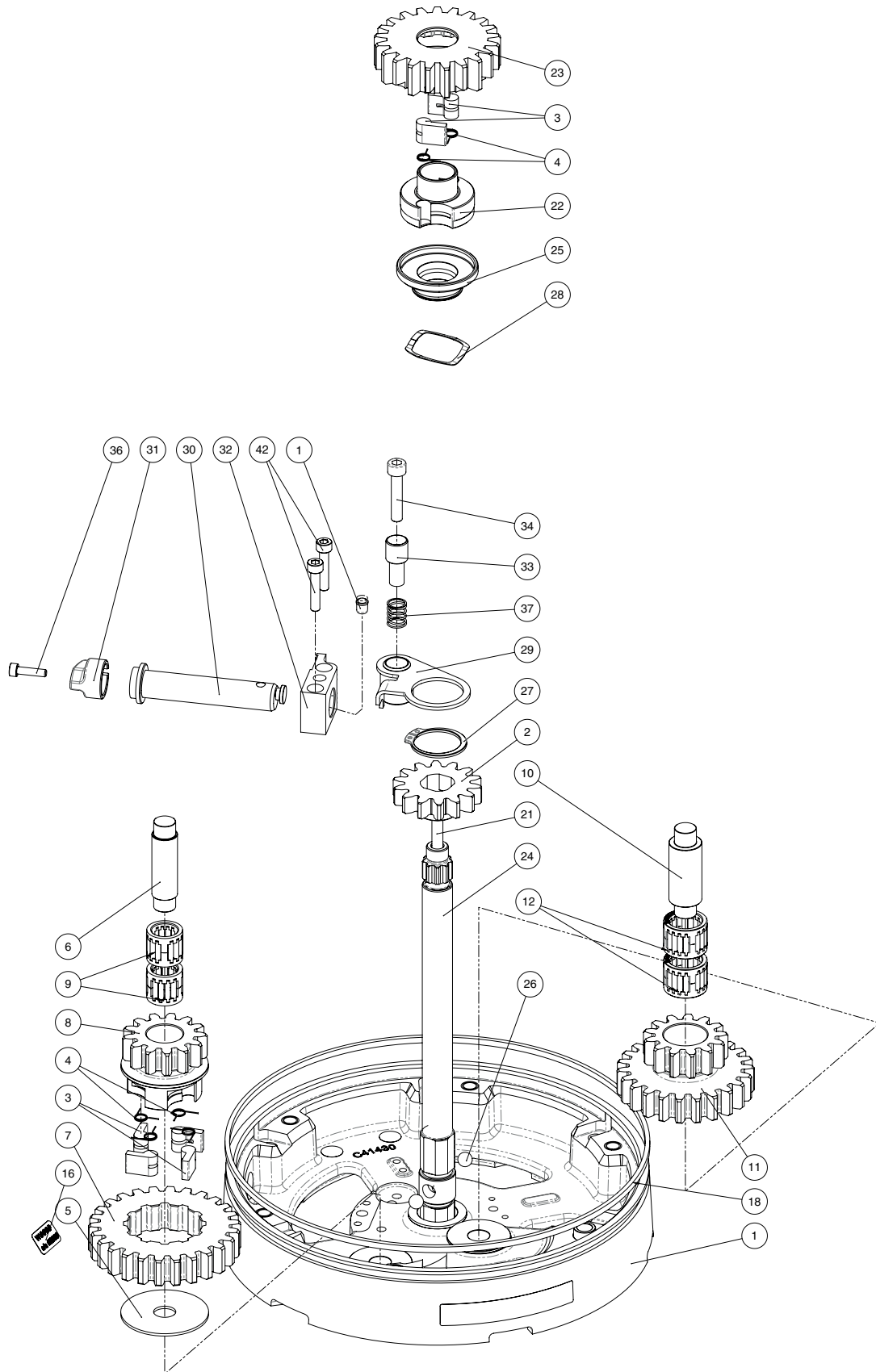

**Parts List**

*Winch 60 Rewind™ STA EL*

A = drum in anodised aluminium

Pos.	Q.ty	Code	Description	Pos.	Q.ty	Code	Description
1	1	A96575800	Assy Base W60 RW <i>Base W60RW</i>	27	1	M0616603	Retaining ring UNI 7435 - Ø28
	1	S476030004	<i>Centering bushing Ø12</i>	28	1	M0630802	Elastic ring SSR0137-S17
	1	S4130900A7	<i>Bushing Ø22xØ25x8.5</i>	29	1	A76575600	Command x W60 Rewind
	2	S415580085	<i>Bushing Ø12xØ35x9</i>	30	1	A96575700	Assy knob W60 Rewind <i>Knob W60 Rewind</i>
	1	M6009463	<i>Spring loaded ball plunger Ø6</i> <i>Winch Product Sticker**</i>		1	S419190004	<i>Heli-coil M4x8</i>
2	1	S657550004	Gear Z14 W60RW		1	S419200041	<i>Pin for knob</i>
3	6	S000080003	Pawl Ø8*		1	S497400180	<i>Bushing Ø6.5xØ4x3</i>
4	6	S000380001	Pawl Spring Ø8*	31	1	S497400180	Knob Rewind
5	1	S278170002	Washer Ø12.5xØ48x1.5	32	1	S657590080	Switch Support W60RW
6	1	S281010004	Pin for gear	33	1	S416530004	Pin for switch
7	1	S414420041	Ratchet Gear Z26xN4	34	1	M0624203	Screw M6x30
8	1	S414410004	Pawls Carrier Gear Z13 N4	35	1	A94165200	Assy socket Rewind <i>Socket Handle</i>
9	2	A72821800	Roller Bearing Ø14xØ20x18		1	S414940085	<i>Washer Ø25xØ15x4</i>
10	1	S416030004	Gear Pin Ø12xØ18x52,5		1	S414930003	<i>Nut Screw for Disconnect Rod</i>
11	1	S414480004	Idler and Pinion Z23/Z13 W60		1	M0679797	<i>O ring RC 2025 series</i>
12	2	A74162300	Roll bearing Ø24xØ18x18	36	1	M0624103	Screw M4x16 UNI5931
13	1	A94143100	Assy Housing Winch 60.2 <i>Housing W60</i>	37	1	S418590001	Spring Ø10.67x12.7
	2	S415580085	<i>Bushing Ø12xØ35x9</i>	38	1	S657620052	Spacer for stripper arm support W60 Rew
	1	S4130900A7	<i>Support Bushing W60</i>	39	4	M0623103	Screw M6x40 TC DIN84 A4
			<i>Bushing Ø22xØ25x8.5</i>	40	4	M0601703	Screw M6x25 UNI 5931
14	6	M0606303	Screw M8x25 UNI 5931	41	3	M6007103	Screw M6x50 UNI6107
15	3	A74145000	Roller Bearing Ø95xØ107x26	42	2	M0627602	Screw M5x25 TCCE U5931 D912 A2
16			Winch Serial Number Sticker	43	1	A96574900	Assy jaws Winch 60 <i>Upper Jaw W60</i>
17	1	S4144300A0	Stripper Arm Housing W60/70				<i>Lower Jaw W60RW</i>
18	1	S281700097	Red line		8	S385970001	<i>Spring</i>
19	1	S6574800B1	Cover 2 Speed W60 REWIND		1	S657610052	<i>Tapered spacer for W60RW drum</i>
20	1	A96575000	Assembly Kit drum Winch 60 STA Rewind <i>Drum Assembly W60 RW</i>		1	S665780080	<i>Spacer ring Winch 60 Rewind</i>
	50	M0610280	<i>Ball 5/16"</i>	44	1	A96574600	Assy stripper arm <i>Stripper arm W60 Rewind</i>
21	1	S657540002	Disconnect rod 60 Rewind		1	S657470019	<i>Peeler W60 Rewind</i>
22	1	S657530004	Pawls carrier Ø8xN2		1	S416570001	<i>Spring stripper arm W46 Rewind</i>
23	1	S657520041	Gear Z21		1	S416580041	<i>Bushing</i>
24	1	S657510004	Main shaft W60 Rewind		2	M0619003	<i>Screw M5x20 UNI 6109</i>
25	1	S416260041	Disconnect flange		1	S419170080	<i>Slider</i>
26	2	M0614103	Ball 5-16" inox				

\*Available with service kit; see website [www.harken.com](http://www.harken.com)

\*\*Winch product sticker



## Winch 60 Rewind™ STC EL

C = drum in chrome bronze

Pos.	Q.ty	Code	Description	Pos.	Q.ty	Code	Description
1	1	A96575800	Assy Base W60 RW <i>Base W60RW</i>	27	1	M0616603	Retaining ring UNI 7435 - Ø28
	1	S476030004	<i>Centering bushing Ø12</i>	28	1	M0630802	Elastic ring SSR0137-S17
	1	S4130900A7	<i>Bushing Ø22xØ25x8.5</i>	29	1	A76575600	Command x W60 Rewind
	2	S415580085	<i>Bushing Ø12xØ35x9</i>	30	1	A96575700	Assy knob W60 Rewind <i>Knob W60 Rewind</i>
	1	M6009463	<i>Spring loaded ball plunger Ø6</i> <i>Winch Product Sticker**</i>		1	S419190004	<i>Heli-coil M4x8</i>
2	1	S657550004	Gear Z14 W60RW		1	S419200041	<i>Pin for knob</i>
3	6	S000080003	Pawl Ø8*		1	S419200041	<i>Bushing Ø6.5xØ4x3</i>
4	6	S000380001	Pawl Spring Ø8*	31	1	S497400180	Knob Rewind
5	1	S278170002	Washer Ø12.5xØ48x1.5	32	1	S657590080	Switch Support W60RW
6	1	S281010004	Pin for gear	33	1	S416530004	Pin for switch
7	1	S414420041	Ratchet Gear Z26xN4	34	1	M0624203	Screw M6x30
8	1	S414410004	Pawls Carrier Gear Z13 N4	35	1	A94165200	Assy socket Rewind <i>Socket Handle</i>
9	2	A72821800	Roller Bearing Ø14xØ20x18		1	S414940085	<i>Washer Ø25xØ15x4</i>
10	1	S416030004	Gear Pin Ø12xØ18x52,5		1	S414930003	<i>Nut Screw for Disconnect Rod</i>
11	1	S414480004	Idler and Pinion Z23/Z13 W60		1	M0679797	<i>O ring RC 2025 series</i>
12	2	A74162300	Roll bearing Ø24xØ18x18	36	1	M0624103	Screw M4x16 UNI5931
13	1	A94143100	Assy Housing Winch 60.2 <i>Housing W60</i>	37	1	S418590001	Spring Ø10.67x12.7
	2	S415580085	<i>Bushing Ø12xØ35x9</i>	38	1	S657620052	Spacer for stripper arm support W60 Rew
	1	S4130900A7	<i>Support Bushing W60</i> <i>Bushing Ø22xØ25x8.5</i>	39	4	M0623103	Screw M6x40 TC DIN84 A4
14	6	M0606303	Screw M8x25 UNI 5931	40	4	M0601703	Screw M6x25 UNI 5931
15	3	A74145000	Roller Bearing Ø95xØ107x26	41	3	M6007103	Screw M6x50 UNI6107
16			Winch Serial Number Sticker	42	2	M0627602	Screw M5x25 TCCE U5931 D912 A2
17	1	S4144300A0	Stripper Arm Housing W60/70	43	1	A96990500	Assy jaws Winch 60STC Rewind <i>Upper Jaw W60</i>
18	1	S281700097	Red line		8	S385970001	<i>Lower Jaw W60RW</i>
19	1	S6574800B1	Cover 2 Speed W60 REWIND		1	S657610041	<i>Spring</i>
20	1	A96645700	Kit Assembly drum Winch 60 STC Rewind <i>Drum Winch 60 Rewind</i>		1	S665780080	<i>Tapered spacer for W60RW drum</i>
	50	M0610280	<i>Ball 5/16"</i>		1	S665780080	<i>Spacer ring Winch 60 Rewind</i>
21	1	S657540002	Disconnect rod 60 Rewind	44	1	A96574600	Assy stripper arm <i>Stripper arm W60 Rewind</i>
22	1	S657530004	Pawls carrier Ø8xN2		1	S657470019	<i>Peeler W60 Rewind</i>
23	1	S657520041	Gear Z21		1	S416570001	<i>Spring stripper arm W46 Rewind</i>
24	1	S657510004	Main shaft W60 Rewind		1	S416580041	<i>Bushing</i>
25	1	S416260041	Disconnect flange		2	M0619003	<i>Screw M5x20 UNI 6109</i>
26	2	M0614103	Ball 5-16" inox		1	S419170080	<i>Slider</i>

\*Available with service kit; see website [www.harken.com](http://www.harken.com)

\*\*Winch product sticker





**Winch 60 Rewind™ STCW EL**

CW = chrome/white

Pos.	Q.ty	Code	Description	Pos.	Q.ty	Code	Description
1	1	A96760800W	Base Assy W60 Rewind RAL9003 <i>Base W60RW</i>	27	1	M0616603	Retaining ring UNI 7435 - Ø28
	1	S6760800A5W	<i>Skirt W60 REWIND RAL9003</i>	28	1	M0630802	Elastic ring SSR0137-S17
	1	S476030004	<i>Centering bushing Ø12</i>	29	1	A76575600	Command x W60 Rewind
	1	S4130900A7	<i>Bushing Ø22xØ25x8.5</i>	30	1	A96575700	Assy knob W60 Rewind <i>Knob W60 Rewind</i>
	2	S415580085	<i>Bushing Ø12xØ35x9</i>		1	S419190004	<i>Heli-coil M4x8</i>
	1	M6009463	<i>Spring loaded ball plunger Ø6</i>		1	S419200041	<i>Pin for knob</i>
			<i>Winch Product Sticker**</i>				<i>Bushing Ø6.5xØ4x3</i>
2	1	S657550004	Gear Z14 W60RW	31	1	S497400180	Knob Rewind
3	6	S000080003	Pawl Ø8*	32	1	S657590080	Switch Support W60RW
4	6	S000380001	Pawl Spring Ø8*	33	1	S416530004	Pin for switch
5	1	S278170002	Washer Ø12.5xØ48x1.5	34	1	M0624203	Screw M6x30
6	1	S281010004	Pin for gear	35	1	A94165200	Assy socket Rewind <i>Socket Handle</i>
7	1	S414420041	Ratchet Gear Z26xN4		1	S414940085	<i>Washer Ø25xØ15x4</i>
8	1	S414410004	Pawls Carrier Gear Z13 N4		1	S414930003	<i>Nut Screw for Disconnect Rod</i>
9	2	A72821800	Roller Bearing Ø14xØ20x18		1	M0679797	<i>O ring RC 2025 series</i>
10	1	S416030004	Gear Pin Ø12xØ18x52,5	36	1	M0624103	Screw M4x16 UNI5931
11	1	S414480004	Idler and Pinion Z23/Z13 W60	37	1	S418590001	Spring Ø10.67x12.7
12	2	A74162300	Roll bearing Ø24xØ18x18	38	1	S657620052	Spacer for stripper arm support W60 Rew
13	1	A94143100	Assy Housing Winch 60.2 <i>Housing W60</i>	39	4	M0623103	Screw M6x40 TC DIN84 A4
	2	S415580085	<i>Bushing Ø12xØ35x9</i>	40	4	M0601703	Screw M6x25 UNI 5931
	1	S4130900A7	<i>Support Bushing W60</i>	41	3	M6007103	Screw M6x50 UNI6107
			<i>Bushing Ø22xØ25x8.5</i>	42	2	M0627602	Screw M5x25 TCCE U5931 D912 A2
14	6	M0606303	Screw M8x25 UNI 5931	43	1	A96574900W	Assy jaws Winch 60 STCW Rewind <i>Upper Jaw W60 RAL 9003</i>
15	3	A74145000	Roller Bearing Ø95xØ107x26				<i>Lower Jaw W60RW</i>
16			Winch Serial Number Sticker		8	S385970001	<i>Spring</i>
17	1	S4144300A0	Stripper Arm Housing W60/70		1	S657610041	<i>Tapered spacer for W60RW C</i>
18	-	-	-		1	S665780080	<i>Spacer ring Winch 60 Rewind</i>
19	1	S6574800B1W	Cover 2 Speed W60 REWIND RAL9003	44	1	A96574600	Assy stripper arm <i>Stripper arm W60 Rewind</i>
20	1	A96645700	Kit Assembly drum Winch 60 STC Rewind <i>Drum Winch 60 Rewind</i>		1	S657470019	<i>Peeler W60 Rewind</i>
	50	M0610280	<i>Ball 5/16"</i>		1	S416570001	<i>Spring stripper arm W46 Rewind</i>
21	1	S657540002	Disconnect rod 60 Rewind		1	S416580041	<i>Bushing</i>
22	1	S657530004	Pawls carrier Ø8xN2		2	M0619003	<i>Screw M5x20 UNI 6109</i>
23	1	S657520041	Gear Z21		1	S419170080	<i>Slider</i>
24	1	S657510004	Main shaft W60 Rewind				
25	1	S416260041	Disconnect flange				
26	2	M0614103	Ball 5-16" inox				

 \*Available with service kit; see website [www.harken.com](http://www.harken.com)

\*\*Winch product sticker



## Winch 60 Rewind™ STBBB EL

BBB = all bronze

Pos.	Q.ty	Code	Description	Pos.	Q.ty	Code	Description
1	1	A96934300	Assy Base W60STBBB Rewind <i>Base W60RW BBB-CCC</i>	27	1	M0616603	Retaining ring UNI 7435 - Ø28
	1	S693430043	<i>Cover for base W60 REW BBB</i>	28	1	M0630802	Elastic ring SSR0137-S17
	1	S476030004	<i>Centering bushing Ø12</i>	29	1	A76575600	Command x W60 Rewind
	1	S4130900A7	<i>Bushing Ø22xØ25x8.5</i>	30	1	A96575700	Assy knob W60 Rewind <i>Knob W60 Rewind</i> <i>Heli-coil M4x8</i>
	2	S415580085	<i>Bushing Ø12xØ35x9</i>		1	S419190004	<i>Pin for knob</i>
	1	M6009463	<i>Spring loaded ball plunger Ø6</i> <i>Winch Product Sticker**</i>		1	S419200041	<i>Bushing Ø6.5xØ4x3</i>
2	1	S657550004	Gear Z14 W60RW	31	1	S497400180	Knob Rewind
3	6	S000080003	Pawl Ø8*	32	1	S657590080	Switch Support W60RW
4	6	S000380001	Pawl Spring Ø8*	33	1	S416530004	Pin for switch
5	1	S278170002	Washer Ø12.5xØ48x1.5	34	1	M0624203	Screw M6x30
6	1	S281010004	Pin for gear	35	1	A94165200	Assy socket Rewind <i>Socket Handle</i>
7	1	S414420041	Ratchet Gear Z26xN4		1	S414940085	<i>Washer Ø25xØ15x4</i>
8	1	S414410004	Pawls Carrier Gear Z13 N4		1	S414930003	<i>Nut Screw for Disconnect Rod</i>
9	2	A72821800	Roller Bearing Ø14xØ20x18		1	M0679797	<i>O ring RC 2025 series</i>
10	1	S416030004	Gear Pin Ø12xØ18x52.5	36	1	M0624103	Screw M4x16 UNI5931
11	1	S414480004	Idler and Pinion Z23/Z13 W60	37	1	S418590001	Spring Ø10.67x12.7
12	2	A74162300	Roll bearing Ø24xØ18x18	38	1	S657620052	Spacer for stripper arm support W60 Rew
13	1	A94143100	Assy Housing Winch 60.2 <i>Housing W60</i>	39	4	M0623103	Screw M6x40 TC DIN84 A4
	2	S415580085	<i>Bushing Ø12xØ35x9</i>	40	4	M0601703	Screw M6x25 UNI 5931
	1	S4130900A7	<i>Support Bushing W60</i> <i>Bushing Ø22xØ25x8.5</i>	41	3	M6007103	Screw M6x50 UNI6107
14	6	M0606303	Screw M8x25 UNI 5931	42	2	M0627602	Screw M5x25 TCCE U5931 D912 A2
15	3	A74145000	Roller Bearing Ø95xØ107x26	43	1	A96990600	Assy jaws Winch 60STBBB Rewind <i>Upper Jaw W60</i> <i>Lower Jaw W60RW BBB</i>
16			Winch Serial Number Sticker		8	S385970001	<i>Spring</i>
17	1	S4144300A0	Stripper Arm Housing W60/70		1	S693490043	<i>Tapered spacer for W60RW drum BBB</i>
18	1	S281700097	Red line		1	S665780080	<i>Spacer ring Winch 60 Rewind</i>
19	1	A76934800	Cover W60 RW BBB	44	1	A76934000	Stripper arm Winch 60 Rewind BBB <i>Stripper arm Winch 60 Rewind BBB</i>
20	1	A96934400	Kit Assembly drum Winch 60 STBBB Rewind <i>Drum Assembly W60STBBB RW</i>		1	S6933900F0	<i>Peeler Winch 60 Rewind BBB</i>
	50	M0610280	<i>Ball 5/16"</i>		1	S416570001	<i>Spring stripper arm W46 Rewind</i>
21	1	S657540002	Disconnect rod 60 Rewind		1	S416580041	<i>Bushing</i>
22	1	S657530004	Pawls carrier Ø8xN2		1	S419170080	<i>Slider</i>
23	1	S657520041	Gear Z21		2	M0619003	<i>Screw M5x20 UNI 6109</i>
24	1	S657510004	Main shaft W60 Rewind				
25	1	S416260041	Disconnect flange				
26	2	M0614103	Ball 5-16" inox				

\*Available with service kit; see website [www.harken.com](http://www.harken.com)

\*\*Winch product sticker





**60 Rewind™ STCCC EL Winch**
**CCC = All-Chrome bronze**

Pos.	Q.ty	Code	Description	Pos.	Q.ty	Code	Description
1	1	A96934500	Base Assy W60STCCC REWIND <i>Base W60RW BBB-CCC</i>	27	1	M0616603	Retaining ring UNI 7435 - Ø28
	1	S693450043	<i>Cover for base W60 REW CCC</i>	28	1	M0630802	Elastic ring SSR0137-S17
	1	S476030004	<i>Centering bushing Ø12</i>	29	1	A76575600	Command x W60 Rewind
	1	S4130900A7	<i>Bushing Ø22xØ25x8.5</i>	30	1	A96575700	Assy knob W60 Rewind <i>Knob W60 Rewind</i>
	2	S415580085	<i>Bushing Ø12xØ35x9</i>		1	S419190004	<i>Heli-coil M4x8</i>
	1	M6009463	<i>Spring loaded ball plunger Ø6</i>		1	S419200041	<i>Pin for knob</i>
			<i>Winch Product Sticker**</i>				<i>Bushing Ø6.5xØ4x3</i>
2	1	S657550004	Gear Z14 W60RW	31	1	S497400180	Knob Rewind
3	6	S000080003	Pawl Ø8*	32	1	S657590080	Switch Support W60RW
4	6	S000380001	Pawl Spring Ø8*	33	1	S416530004	Pin for switch
5	1	S278170002	Washer Ø12.5xØ48x1.5	34	1	M0624203	Screw M6x30
6	1	S281010004	Pin for gear	35	1	A94165200	Assy socket Rewind <i>Socket Handle</i>
7	1	S414420041	Ratchet Gear Z26xN4		1	S414940085	<i>Washer Ø25xØ15x4</i>
8	1	S414410004	Pawls Carrier Gear Z13 N4		1	S414930003	<i>Nut Screw for Disconnect Rod</i>
9	2	A72821800	Roller Bearing Ø14xØ20x18		1	M0679797	<i>O ring RC 2025 series</i>
10	1	S416030004	Gear Pin Ø12xØ18x52,5	36	1	M0624103	Screw M4x16 UNI5931
11	1	S414480004	Idler and Pinion Z23/Z13 W60	37	1	S418590001	Spring Ø10.67x12.7
12	2	A74162300	Roll bearing Ø24xØ18x18	38	1	S657620052	Spacer for stripper arm support W60 Rew
13	1	A94143100	Assy Housing Winch 60.2 <i>Housing W60</i>	39	4	M0623103	Screw M6x40 TC DIN84 A4
	2	S415580085	<i>Bushing Ø12xØ35x9</i>	40	4	M0601703	Screw M6x25 UNI 5931
	1	S4130900A7	<i>Support Bushing W60</i>	41	3	M6007103	Screw M6x50 UNI6107
			<i>Bushing Ø22xØ25x8.5</i>	42	2	M0627602	Screw M5x25 TCCE U5931 D912 A2
14	6	M0606303	Screw M8x25 UNI 5931	43	1	A96934600	Assy jaws Winch 60 STCCC Rewind <i>Upper Jaw W60 RAL 9003</i>
15	3	A74145000	Roller Bearing Ø95xØ107x26				<i>Lower Jaw W60RW CCC</i>
16			Winch Serial Number Sticker		8	S385970001	<i>Spring</i>
17	1	S4144300A0	Stripper Arm Housing W60/70		1	S657610041	<i>Tapered spacer for W60RW C</i>
18	1	S281700097	Red line		1	S665780080	<i>Spacer ring Winch 60 Rewind</i>
19	1	A76934700	Assy cover W60 RW CCC	44	1	A96574600	Assy stripper arm <i>Stripper arm W60 Rewind</i>
20	1	A96645700	Kit Assembly drum Winch 60 STC Rewind <i>Drum Winch 60 Rewind</i>		1	S657470019	<i>Peeler W60 Rewind</i>
	50	M0610280	<i>Ball 5/16"</i>		1	S416570001	<i>Spring stripper arm W46 Rewind</i>
21	1	S657540002	Disconnect rod 60 Rewind		1	S416580041	<i>Bushing</i>
22	1	S657530004	Pawls carrier Ø8xN2		2	M0619003	<i>Screw M5x20 UNI 6109</i>
23	1	S657520041	Gear Z21		1	S419170080	<i>Slider</i>
24	1	S657510004	Main shaft W60 Rewind				
25	1	S416260041	Disconnect flange				
26	2	M0614103	Ball 5-16" inox				

\*Available with service kit; see website [www.harken.com](http://www.harken.com)

\*\*Winch product sticker



Horizontal electric motor 12V/24V

**TOP VIEW**

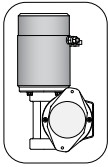

\* Motor installed in right-hand configuration.

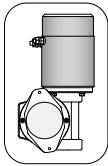

\*\* Motor installed in left-hand configuration.

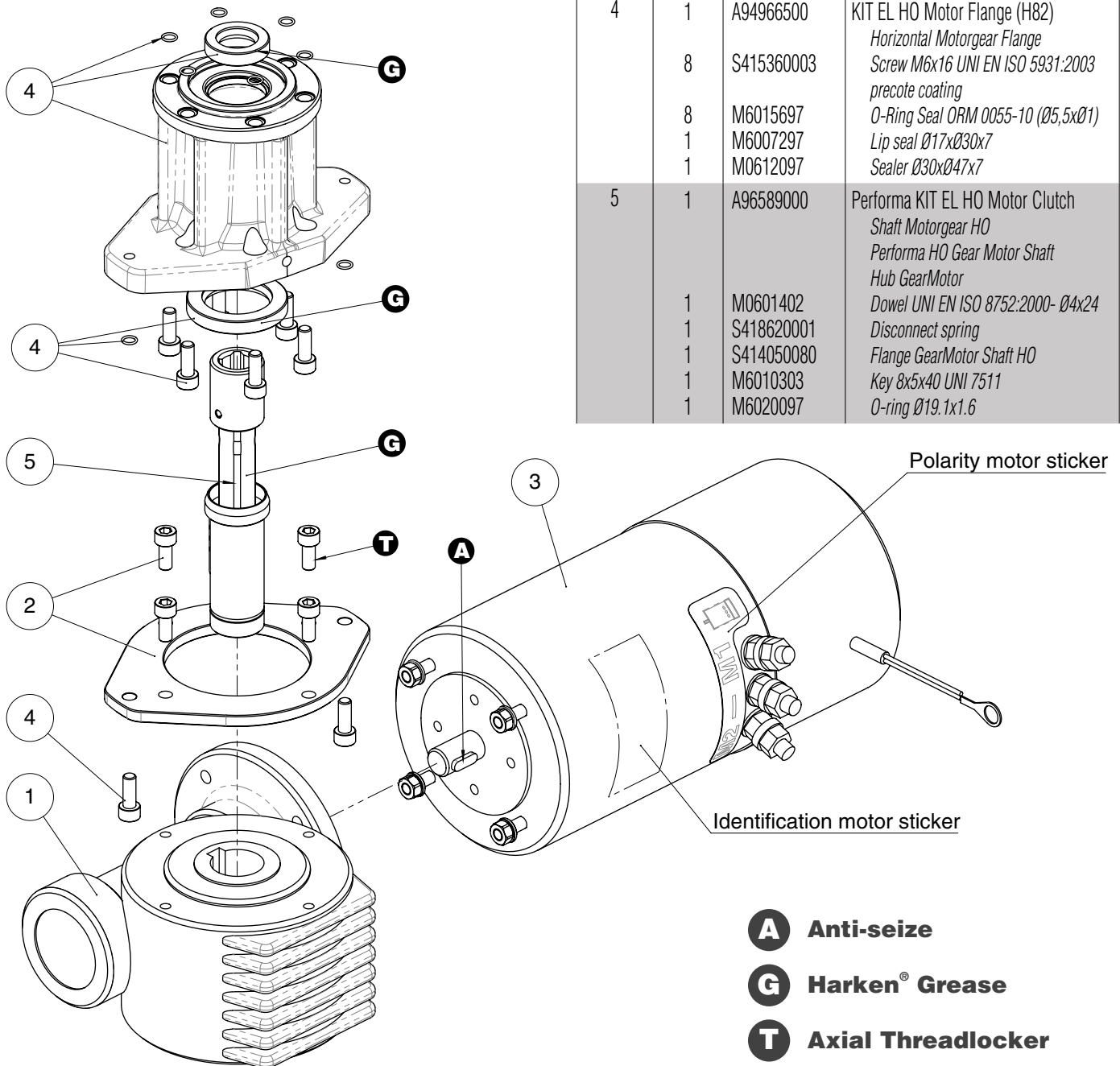

Pos.	Q.ty	Code	Description
1	1	A93127900	KIT Gear Reduction VF49
	1	A94194900	KIT LM Gear Reduction 1/24
2	1	A94149200	KIT Assy Electric Motor Flange
	1	A94149200L	KIT Assy Electric Motor Flange Left
	4	M0606803	Electric Motor Flange Screw M6x14 UNI 5931
3	1	A96656800	Kit electric motor HO 12V W.60 RW
	1	A96656900	Kit electric motor OR 24V Winch 60 RW
4	1	A94966500	Kit EL HO Motor Flange (H82)
	8	S415360003	Horizontal Motorgear Flange Screw M6x16 UNI EN ISO 5931:2003 precote coating
	8	M6015697	O-Ring Seal ORM 0055-10 (Ø5,5xØ1)
	1	M6007297	Lip seal Ø17xØ30x7
	1	M0612097	Sealer Ø30xØ47x7
5	1	A96589000	Performa KIT EL HO Motor Clutch
			Shaft Motorgear HO
			Performa HO Gear Motor Shaft
			Hub GearMotor
	1	M0601402	Dowel UNI EN ISO 8752:2000- Ø4x24
	1	S418620001	Disconnect spring
	1	S414050080	Flange GearMotor Shaft HO
1	M6010303	Key 8x5x40 UNI 7511	
1	M6020097	O-ring Ø19.1x1.6	

Polarity motor sticker

Identification motor sticker

- A** Anti-seize
- G** Harken® Grease
- T** Axial Threadlocker