

# Installation and Maintenance Manual

MRRW-02

## Radial<sup>®</sup> Electric Winch 60 Rewind<sup>™</sup>

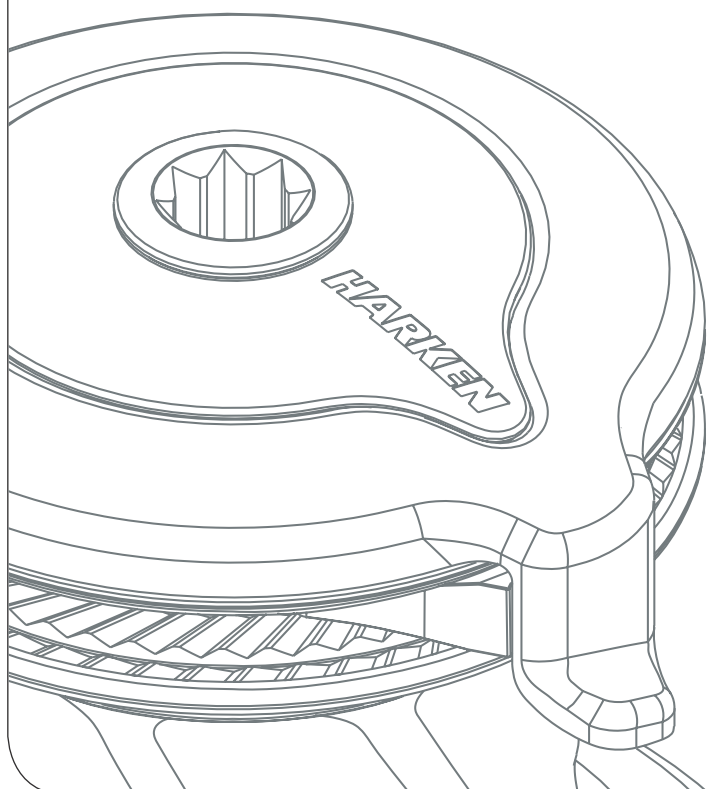

**HARKEN<sup>®</sup>**

<b>Introduction</b>	3
<b>Technical characteristics</b>	3
Performance data	3
Weight	3
Maximum working load	4
<b>Outline</b>	4
Radial® 60 Rewind™	4
Horizontal electric motor	4
<b>Installation</b>	4
Winch installation procedure	6
Winch drilling cut-out	9
Positioning the self-tailing arm	10
Motor installation procedure	11
Electric wiring diagrams	12
<b>Maintenance</b>	13
Washing	13
Maintenance table	13
Winch disassembly procedure	14
Winch exploded view with maintenance products	17
Winch assembly	18
<b>Harken® limited worldwide warranty</b>	19
<b>Ordering spare parts</b>	19
<b>Exploded view</b>	20
Radial® 60 Rewind™ Winch	20
Horizontal electric motor	25
<b>Parts list</b>	22
Radial® 60 STA Rewind™ Winch	22
Radial® 60 STC Rewind™ Winch	23
Radial® 60 STCW Rewind™ Winch	24
Horizontal electric motor 12V	25
Horizontal electric motor 24V	26

## Introduction

This manual gives technical information on winch installation and maintenance, including disassembling and reassembling.

This information is DESTINED EXCLUSIVELY for specialised personnel or expert users.

Installation, disassembling and reassembling of the winch by personnel who are not experts may cause serious damage to users and those in the vicinity of the winch.

Harken® accepts no responsibility for defective installation or reassembly of its winches.

In case of doubt the Harken® Tech Service is at your disposal at [techservice@harken.it](mailto:techservice@harken.it)

This Manual is available only in English. If you do not fully understand the English language, do not carry out the operations described in this Manual.

## Technical characteristics

	Power ratio	Gear ratio
1st speed	20,24 : 1	4,80 : 1
2nd speed	60,73 : 1	14,41 : 1

*The theoretical power ratio does not take friction into account.*

### Performance data

#### 60 Rewind™ Winch

	horizontal motor		horizontal motor	
	12 V (1500 W)		24 V (2000 W)	
	1st speed	2nd speed	1st speed	2nd speed
line speed (m/min)**	17,7	5,9	17,7	5,9
max load (Kg)	606	1800	606	1800

*\*\*Line speed is measured with no load*

		motor nominal power (W)		current absorption at winch MWL (A)	
		12 V	24 V	12 V	24 V
		60 Rewind™ Winch	horizontal	1500	2000

### Weight

	ST A	ST C
weight (Kg)	22	26

Versions:

A = drum in anodised aluminium

C = drum in chromed steel

## Maximum working load



### **WARNING!**

The maximum working load (MWL) for the 60 Rewind™ Winch is 1800 Kg (3968 lb). Subjecting the winch to loads above the maximum working load can cause the winch to fail or pull off the deck suddenly and unexpectedly during high loads causing severe injury or death.

## Outline

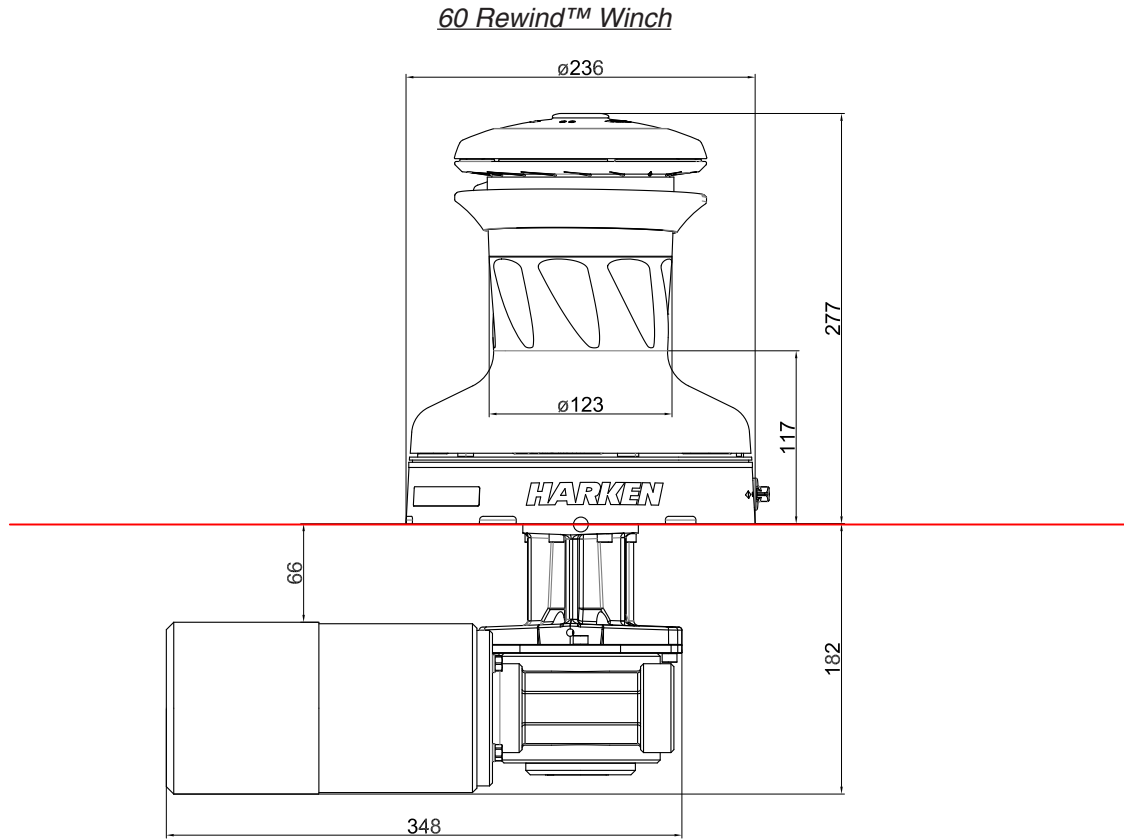

## Installation

The winch must be installed on a flat area of the deck, reinforced if necessary to bear a load equal to at least twice the maximum working load of the winch.

It is the installer's responsibility to carry out all structural tests needed to ensure that the deck can bear the load.

Harken® does not supply the screws needed to install the winch since these may vary depending on the deck on which it is to be installed.

It is the installer's responsibility to choose the correct screws taking account of the loads they will have to bear.

Harken® assumes no responsibility for incorrect installation of its winches or for an incorrect choice of mounting screws.



### **DANGER!**

Incorrect installation of the winch may cause severe injury or death. Consult the yard that built the boat in the case of doubt over the correct positioning of the winch.



**WARNING!**

Failure to use the correct number and type of mounting fasteners or failure to ensure the correct deck strength can result in the winch pulling off the deck suddenly and unexpectedly during high loads causing severe injury or death.



**WARNING!**

Verify the entry angle of the sheet. This must be  $8^\circ$  with tolerance of  $\pm 2^\circ$ , to avoid sheet overrides and damaging the winch or making the winch inoperable leading to loss of control of the boat which can lead to severe injury or death.



**WARNING!**

Mount the winch on the deck so that the final drive gear is positioned where the sheet enters the winch drum. Incorrect position of drive gear can weaken winch leading to failure which can cause an accident leading to severe injury or death.

**NOTICE**

You can find the icon ▲ on the skirt to identify the drive gear position.

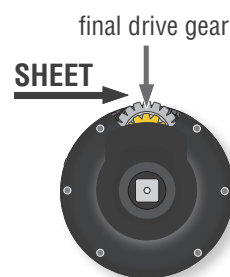
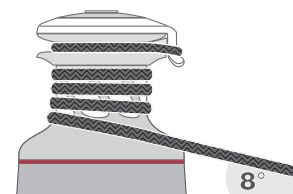

After correctly positioning the final drive gear with respect to the load, check that the motor, gearing, electrical wiring and/or hydraulic pipes can be housed below decks. To help find the optimal compromise, remember that, to make the installation of the motor easier, it can be coupled to the winch in any one of four different positions that differ by  $60^\circ$  from each other.

Once you have decided the correct mounting position for the winch on the deck and checked the space available below deck, proceed with the installation.

The winch can be installed following the two procedure below (**Winch installation procedure**).



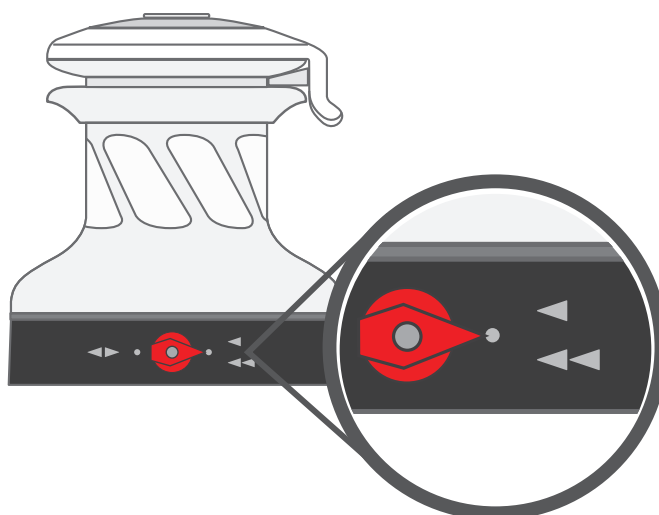

**Before starting the Installation procedure, set the knob in the following position:**



### Winch installation procedure

To install the winch you must remove the drum and use Socket Head (SH) bolts.

#### Tools needed

-  One medium flat-bladed screwdriver
-  A number 5 hex key
-  A number 6 hex key
-  A number 3 hex key

To identify the various parts, refer to the exploded view at the end of this Manual.

 Torque to apply when assembling



1. Pull out the disconnect rod n°22



2. Unscrew the central screw ( $\curvearrowright$  2Nm/18 in-lb)



3. Slide off the assy socket n°38 and the cover n°19.  
Pay attention to the o-ring in the socket.



4. Unscrew the three screws n°42  
( $\curvearrowright$  4Nm/35 in-lb)



5. Remove the stripper arm n°48 by rotating and lifting it.



6. Lift off the drum n°20

Install the winch on the deck in the position you have chosen, keeping in mind the limits described on page 4 and using socket head (SH) bolts.

*Follow steps below only to install the winch using hexagonal headed bolts*



7. Unscrew the 6 hex screws n°14  
( $\approx$  20Nm/177 in-lb)



8. Lift off the spacer n°41



9. Remove the stripper arm n°48 by rotating and lifting it.

Install the winch on the deck in the position you have chosen, keeping in mind the limits described on page 4 and using hexagonal headed M8 bolts.



### Winch drilling cut-out

#### **NOTICE**

Before drilling the deck, check the space available below deck for the flange and the motor

- A.** Position the base of the winch on the deck and mark the position of the holes or use the drilling cut-out template at the point where you have decided to place the winch.

Below is a reduced scale diagram.

The drilling cut out template is available on the Harken® website, [www.harken.com](http://www.harken.com)

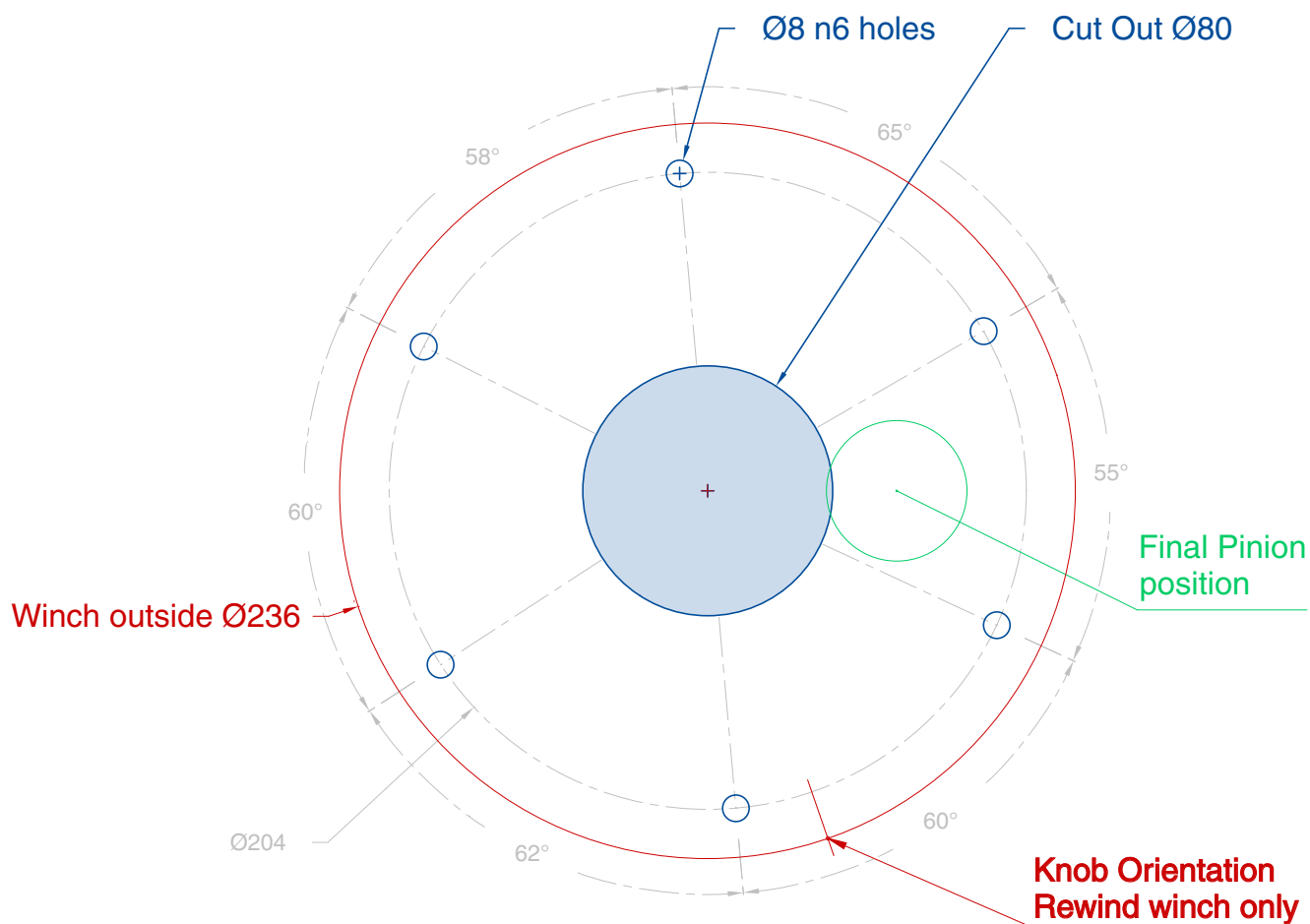

- B.** Remove the winch and drill the six 8.5 mm diameter holes.
- C.** Bolt the base of the winch to the deck using six M8 Socket Head (SH) bolts for Winch installation procedure (not supplied by Harken®), correctly chosen for the thickness and type of the boat deck. Consult the yard that built the boat in case of doubt.



#### **WARNING!**

To install the winch on the deck, use only bolts in A4 stainless steel (DIN 267 part11). Bolts made of other materials may not have sufficient strength or may corrode which can result in winch pulling off deck suddenly and unexpectedly during high loads causing severe injury or death.

#### **NOTICE**

To mount winches on the deck, do not use countersunk bolts.

- D.** Fill the mounting holes with a suitable marine sealant.
- E.** Remove the excess adhesive/sealant from the holes and base drainage channels
- F.** Reassemble the winch following the steps in **Winch installation procedure** in the reverse order, and apply the products indicated in the section on maintenance.

*Positioning the self-tailing arm*

Position the self-tailing arm so that the line leaving the winch is led into the cockpit.

## Motor installation procedure

Once you have installed the winch on the deck, proceed with motor installation. The motor can be coupled to the winch in different positions. Check the space available below deck and choose the suitable position.

### Tools needed

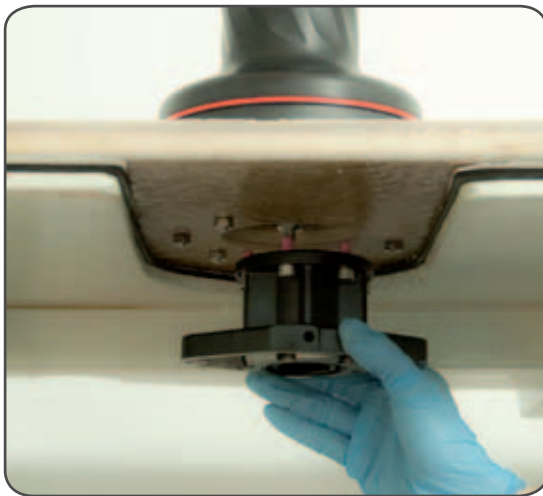
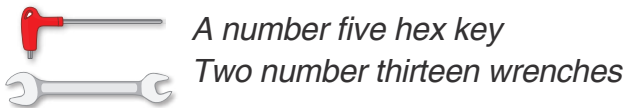

1. Position the flange (see Page 12)



2. Tighten the six screws (8 Nm/ 71 in-lb)



3. Position the reduction gear and motor



4. Tighten the two screws (8 Nm/ 71in-lb).  
Be sure to align the flange.

**NOTICE**

Before positioning the flange, check to make sure that seal is seated correctly.



After winch is assembled and before sailing, test the powered winch functioning.

Electric wiring diagrams

Refer to the following diagrams for the electric wiring:

Fasten electric control box containing solenoids to bulkhead or wall. Install remote circuit breaker between power supply and electric control box. Locate push-buttons on deck in a convenient spot for easy winch operation.

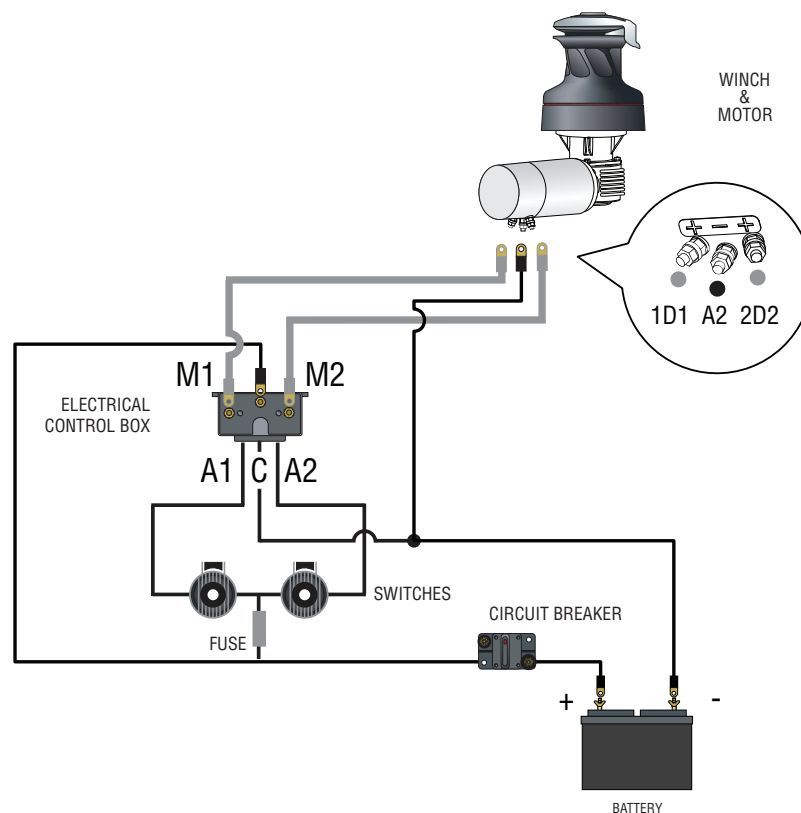

Refer to the following chart for wire size:

Total distance between winch and battery

Winch	Current voltage	Under 16.4 ft AWG	Under 5 m mm <sup>2</sup>	16.4 - 32.8 ft AWG	5 m - 10 m mm <sup>2</sup>	32.8 - 49.2 ft AWG	10 m - 15 m mm <sup>2</sup>	49.2 - 65.6 ft AGW	15 m - 20 m mm <sup>2</sup>
60 Rewind™	12 V	2	32	0	50	00	70	000	95
60 Rewind™	24 V	5	16	3	25	2	35	0	50

**NOTICE**

To connect motor, attach cable terminals to clamps between nut and lock nut. Hold nut in contact with motor using a spanner and tighten other nut with second spanner. Take special care not to turn the central spindles. Be careful not to turn central spindles. These instructions apply when assembling and disassembling. We recommend using a torque wrench so as to obtain a torque equal to and no greater than 10 Nm (88 in-lb).

**NOTICE**

Note that correct electrical contact sequence is:  
Nut – Cable Terminal – Self-Locking Washer – Lock Nut

**Maintenance**Washing

Winches must be washed frequently with fresh water, and in any case after each use. Do not allow teak cleaning products or other cleaners containing caustic solutions to come into contact with winches and especially anodised, chrome plated or plastic parts. Do not use solvents, polishes or abrasive pastes on the logos or stickers on the winches. Make sure that the holes and drainage channels in the base of the winch are not obstructed so that water does not collect.

Maintenance table

Winches must be visually inspected at the beginning and end of every season of sailing or racing. In addition they must be completely overhauled, cleaned and lubricated at least every 12 months. After an inspection, replace worn or damaged components. Do not replace or modify any part of the winch with a part that is not original.



**WARNING!**

Periodic maintenance must be carried out regularly. Lack of adequate maintenance shortens the life of the winch, can cause serious injury and also invalidate the winch warranty. Installation and maintenance of winches must be carried out exclusively by specialized personnel.

In the case of doubt contact Harken® Tech Service at [techservice@harken.it](mailto:techservice@harken.it)



**WARNING!**

Make sure that the power is switched off before installing or carrying out maintenance on the winch.

Winch disassembly procedure

*Tools needed*



*One medium flat-bladed screwdriver*



*A number five and six hex key*



*Brush*



*Rags*

To identify the various parts refer to the exploded view at the end of this Manual.

 Torque to be applied in assembly phase

Carry out **Winch Installation Procedure** as shown in the paragraph on winch installation and then do the following:

If it is necessary to replace any **jaws** of the winch, proceed as follows:



7. Unscrew the 6 hex screws n°14  
( 20Nm/177 in-lb)



8. Lift off the spacer n°41



9. Remove the stripper arm n°48 by rotating and lifting it



10. Slide out the central shaft n°25



11. Remove the idler and pinion n°11 and slide out the two roller bearing n°12



12. Remove the pawls carrier gear n°8 and slide out the 2 roller bearings n°9



13. Remove the ratchet gear n°7

Inspect balls inside the drum and carefully check the correct position; if it is necessary to put back



I. Unscrew the 4 screws n°43  
( $\approx 4\text{Nm}/35\text{ in-lb}$ )



II. Remove the jaws n°54

any balls, push balls in the race (as shown below):

Once the winch is completely disassembled, clean the parts: use a basin of diesel oil to soak



metal components and rinse plastic parts in fresh water. Once you have done this, dry the parts with cloths that do not leave residue.

Inspect gears, bearings, pins and pawls for any signs of wear or corrosion.

Carefully check the teeth of gears and ring gears to make sure there are no traces of wear.

Check the roller bearings and check there are no breaks in the bearing cages.  
Replace worn or damaged components.

Carry out maintenance on components using the products listed below.  
For more information on which products to use where, refer to the exploded diagram below.

Use a brush to lightly lubricate all gears, gear pins, teeth and all moving parts with grease.  
Lightly lubricate the pawls and springs with oil. Do not use grease on the pawls!



Winch exploded view with maintenance products

- A** Anti-seize
- G** Harken® Grease
- O** Harken® Pawl Oil

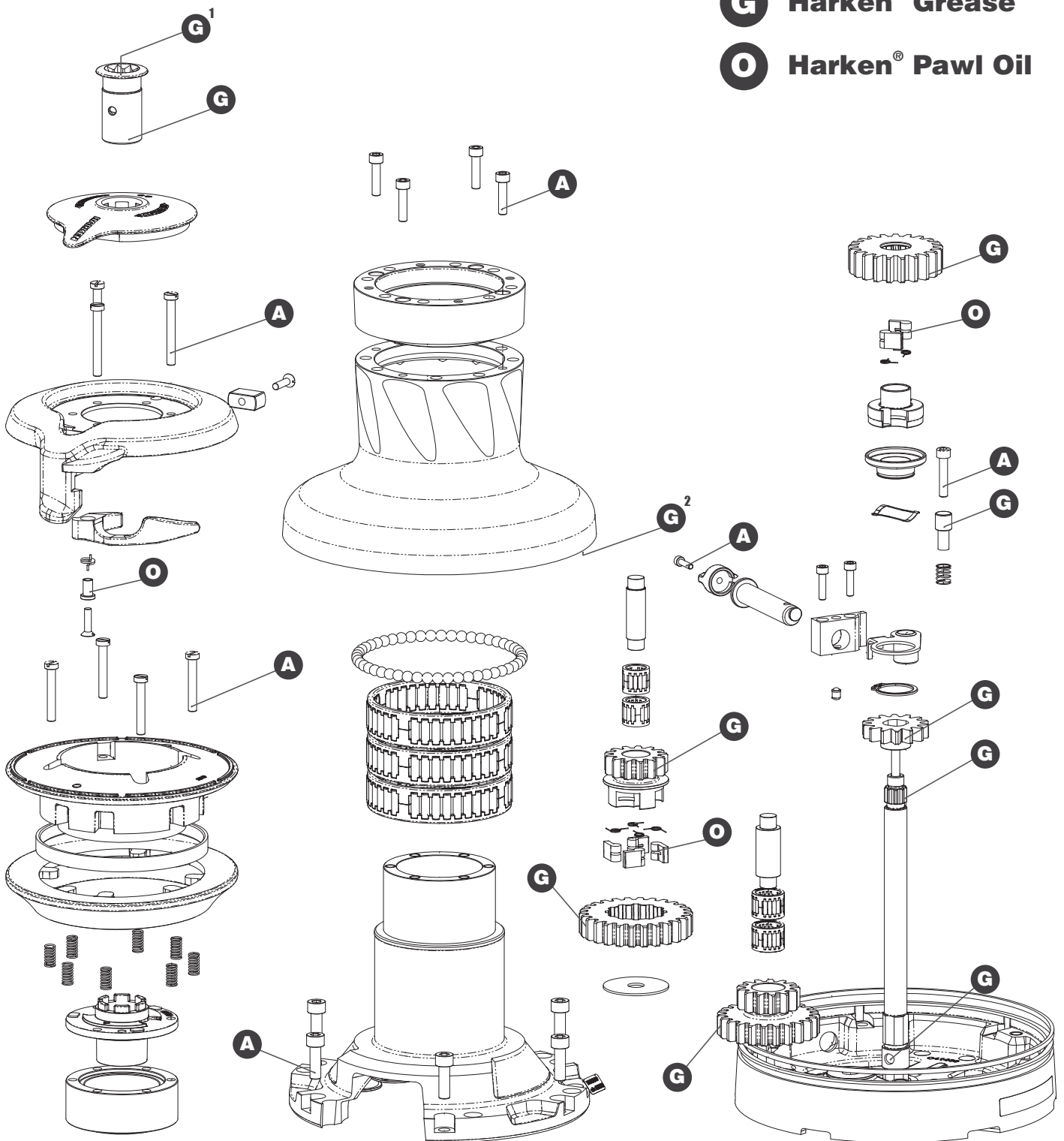

<sup>1</sup>Apply Harken® grease on assy socket screw  
<sup>2</sup>Apply Harken® grease on drum gear

Winch assembly

Make sure that the holes and drainage channels in the base of the winch are not obstructed  
 Assemble the winch in the reverse order of the sequence in the section on disassembly.

To tighten bolts, use the torque indicated in the disassembly procedure.

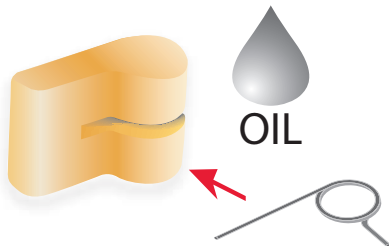

**To assemble the pawls:**

correctly position the spring in its housing as shown at left. Hold the spring closed and slide the pawl into its housing. Once in position, check that the pawls can be easily opened and closed with a finger.

**NOTICE!** Before closing the winch, make sure the holes and drainage channels in the base of the winch are not obstructed.

**NOTICE!** Before screw the central screw, check the correct position of the o-ring in the assy socket

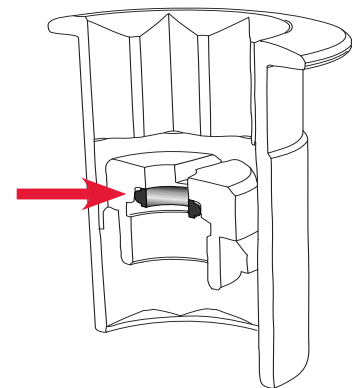

**NOTICE!** Insert the disconnect rod in the winch, with the groove in the lower part of the rod.

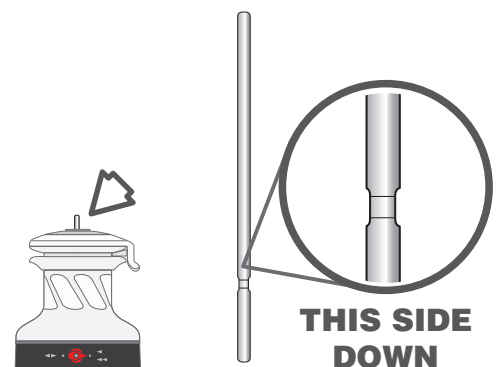

In case of doubt concerning the assembly procedure contact Harken® Tech Service: [techservice@harken.it](mailto:techservice@harken.it)

**Harken® limited worldwide warranty**

Refer to the Harken® Limited Worldwide Warranty in the Harken® Catalogue and on the website [www.harken.com](http://www.harken.com)

**Ordering spare parts**

Spare parts can be requested from Harken® as described in the Harken® Limited Worldwide Warranty, indicating the part number in the Parts List and including the serial number of the winch for which the parts are required.

***The serial number of the winch is printed on a plate on the drum support of the winch.***



**Manufacturer**

**Harken® Italy S.p.A.**  
 Via Marco Biagi, 14  
 22070 Limido Comasco (CO) Italy  
 Tel: (+39) 031.3523511  
 Fax: (+39) 031.3520031  
 Email: [info@harken.it](mailto:info@harken.it)  
 Web: [www.harken.com](http://www.harken.com)

- **Tech Service**  
 Email: [techservice@harken.it](mailto:techservice@harken.it)
- **Customer Service**  
 Tel: (+39) 031.3523511  
 Email: [info@harken.it](mailto:info@harken.it)

**Headquarters**

**Harken®, Inc.**  
 1251 East Wisconsin Avenue  
 Pewaukee, Wisconsin 53072-3755 USA  
 Tel: (262) 691.3320  
 Fax: (262) 691.3008  
 Email: [harken@harken.com](mailto:harken@harken.com)  
 Web: [www.harken.com](http://www.harken.com)

- **Tech Service**  
 Email: [technicalservice@harken.com](mailto:technicalservice@harken.com)
- **Customer Service**  
 Tel: (262) 691-3320  
 Email: [customerservice@harken.com](mailto:customerservice@harken.com)

*Radial*<sup>®</sup> 60 STA Rewind<sup>™</sup> Winch

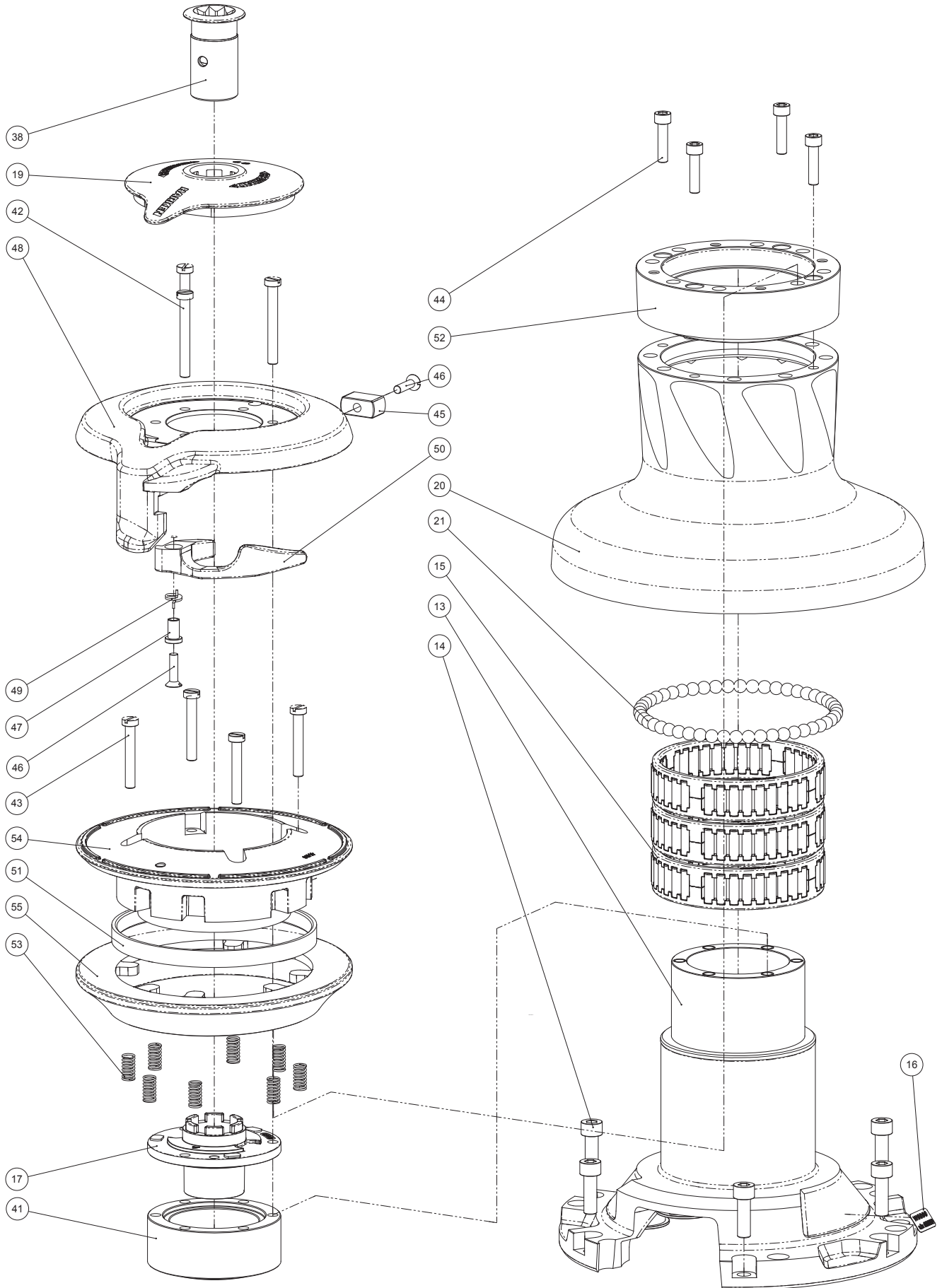

*Radial*<sup>®</sup> 60 STA Rewind<sup>™</sup> Winch

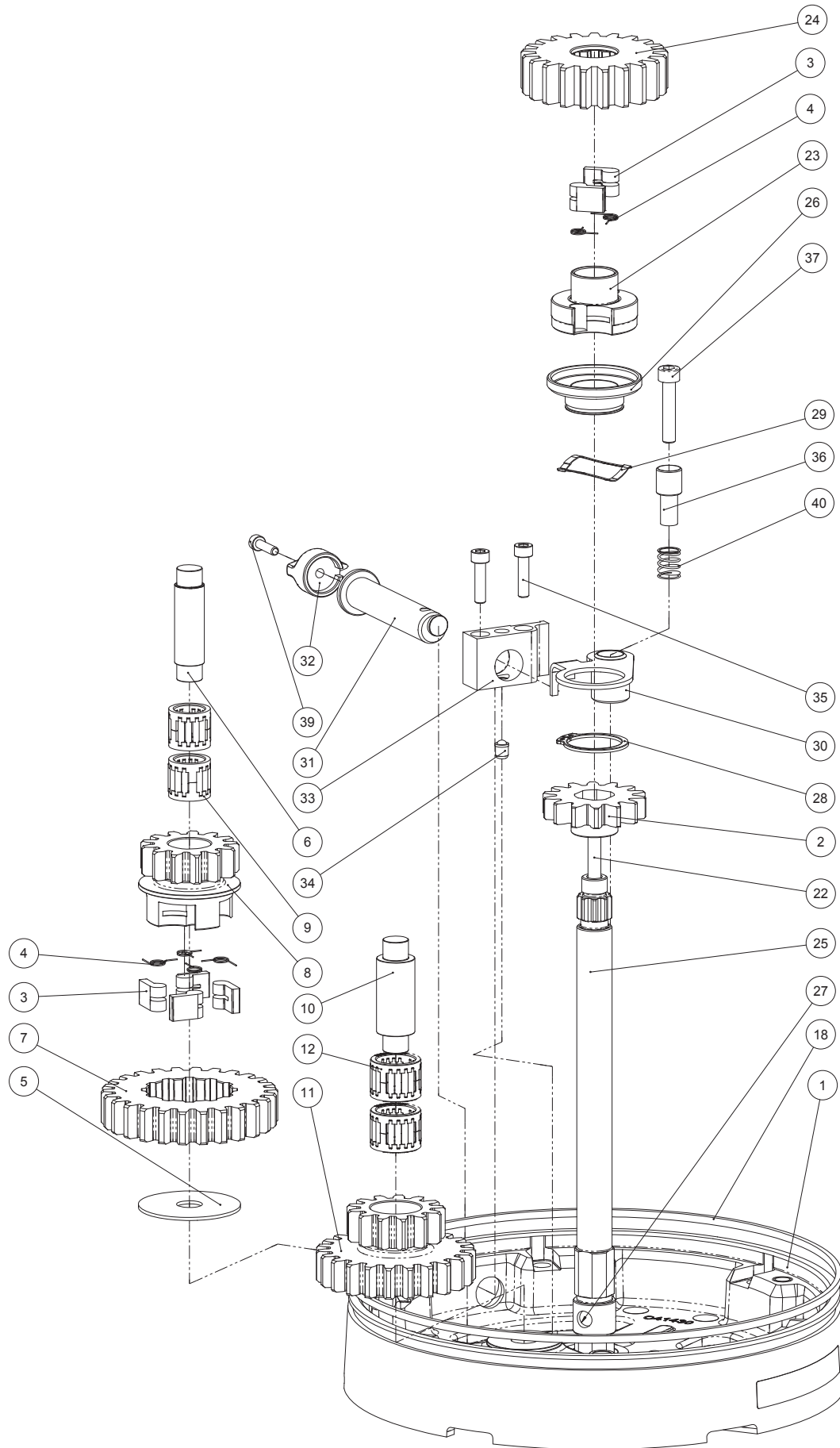

## Radial® 60 STA Rewind™ Winch

Pos.	Q.ty	Code	Description	Pos.	Q.ty	Code	Description
1	1	A 965758 00	Assy Base W60**	29	1	M 06308 02	SMALLEY RING SSR0137-S17
2	1	S 65755 00 04	Gear Z14 W60	30	1	A 765756 00	Command x W60
3	6	S 00008 00 03	Pawl Ø8*	31	1	A 965757 00	Assy knob W60
4	6	S 00038 00 01	Pawl Spring dia 8*	32	1	S 49740 00 80	Knob W46
5	1	S278170002	Washer 12.5x48x1.5*	33	1	S 65759 00 80	Swich Support W60
6	1	S281010004	Pin for gear	34	1	M6009463	Spring loaded ball plunger Ø6*
7	1	S 41442 00 41	Rachet Gear Z26xN4	35	2	M 06446 03	Hex key M5x20 UNI 5931*
8	1	S 41441 00 04	Pawls Carrier Gear Z13 N4	36	1	S 41653 00 04	Pin for switch W46
9	2	A72821800	Roller Bearing 14/20/18*	37	1	M 06242 03	Screw M6x30*
10	1	S 41603 00 04	Gear Pin Ø12xØ18x52,5	38	1	A 941652 00	Assy socket W46
11	1	S 41448 00 04	Idler and Pinion Z23/Z13 W60	39	1	M0624103	Screw M4x16 UNI5933*
12	2	A 741623 00	Roll bearing 24x18x18*	40	1	S 41859 00 01	Spring Ø10.67x12.7 rif.SPEC C0420-035-0500S*
13	1	A 941431 00	Assy Housing Winch 60 <i>Winch Serial Number Sticker</i>	41	1	S 65762 00 52	Spacer for stripperarm support W60*
14	6	M0606303	Screw M8x25 UNI 5931*	42	3	S 41875 00 03	Screw M6x50 U6107 Teflon Coating*
15	3	A 741450 00	Roller Bearing Ø95xØ107x26*	43	4	M0623103	Screw M6x40 TC DIN84 A4*
16	1	S 41876 00 63	Winch Serial Number Sticker	44	4	M 06017 03	Screw M6x25 UNI 5931*
17	1	S 41443 00 A0	Stripper Arm Housing W60	45	1	S 41917 00 80	Slider
18	1	S 28170 00 97	Red line	46	2	M 06190 03	Screw M5x20 UNI 6109*
19	1	S 65748 00 B1	Cover 2 Speed W60	47	1	S 41658 00 41	Bushing
20	1	A 765750 00	Drum Assembly W60	48	1	S 65746 00 03	Stripper-arm W60
21	50	M 06102 80	Ball 5/16"	49	1	S 41657 00 01	Spring stripper arm W46
22	1	S 65754 00 02	Disconnect rod 60	50	1	S 65747 00 19	Peeler W60 Rewind
23	1	S 65753 00 04	Pawls carrier Ø8xN2*	51	1	S 66578 00 80	Spacer ring Winch 60*
24	1	S 65752 00 41	Gear Z23	52	1	S 65761 00 52	Tapered spacer for W60 drum
25	1	S 65751 00 04	Main shaft W60	53	8	S385970001	Spring*
26	1	S 41626 00 41	Disconnect flange	54	1	S 41436 00 A9	Upper Jaw W60
27	2	M 06141 03	Ball 5-16" inox	55	1	S 65749 00 53	Lower Jaw W60
28	1	M0616603	Seeger Ring UNI 7435:1975 - Ø28 mat. 17-7 Ph				

\*Service kit available; see winch kit section on the website [www.harken.com](http://www.harken.com)

\*\*Winch product sticker



**Radial® 60 STC Rewind™ Winch**

Pos.	Q.ty	Code	Description	Pos.	Q.ty	Code	Description
1	1	A 965758 00	Assy Base W60**	29	1	M 06308 02	SMALLEY RING SSR0137-S17
2	1	S 65755 00 04	Gear Z14 W60	30	1	A 765756 00	Command x W60
3	6	S 00008 00 03	Pawl Ø8*	31	1	A 965757 00	Assy knob W60
4	6	S 00038 00 01	Pawl Spring dia 8*	32	1	S 49740 00 80	Knob W46
5	1	S278170002	Washer 12.5x48x1.5*	33	1	S 65759 00 80	Swich Support W60
6	1	S281010004	Pin for gear	34	1	M6009463	Spring loaded ball plunger Ø6*
7	1	S 41442 00 41	Rachet Gear Z26xN4	35	2	M 06446 03	Hex key M5x20 UNI 5931*
8	1	S 41441 00 04	Pawls Carrier Gear Z13 N4	36	1	S 41653 00 04	Pin for switch W46
9	2	A72821800	Roller Bearing 14/20/18*	37	1	M 06242 03	Screw M6x30*
10	1	S 41603 00 04	Gear Pin Ø12xØ18x52,5	38	1	A 941652 00	Assy socket W46
11	1	S 41448 00 04	Idler and Pinion Z23/Z13 W60	39	1	M0624103	Screw M4x16 UNI5933*
12	2	A 741623 00	Roll bearing 24x18x18*	40	1	S 41859 00 01	Spring Ø10.67x12.7 rif.SPEC C0420-035-0500S*
13	1	A 941431 00	Assy Housing Winch 60 <i>Winch Serial Number Sticker</i>	41	1	S 65762 00 52	Spacer for stripperarm support W60*
14	6	M0606303	Screw M8x25 UNI 5931*	42	3	S 41875 00 03	Screw M6x50 U6107 Teflon Coating*
15	3	A 741450 00	Roller Bearing Ø95xØ107x26*	43	4	M0623103	Screw M6x40 TC DIN84 A4*
16	1	S 41876 00 63	Winch Serial Number Sticker	44	4	M 06017 03	Screw M6x25 UNI 5931*
17	1	S 41443 00 A0	Stripper Arm Housing W60	45	1	S 41917 00 80	Slider
18	1	S 28170 00 97	Red line	46	2	M 06190 03	Screw M5x20 UNI 6109*
19	1	S 65748 00 B1	Cover 2 Speed W60	47	1	S 41658 00 41	Bushing
20	1	A 766457 00	Drum Assembly W60	48	1	S 65746 00 03	Stripper-arm W60
21	50	M 06102 80	Ball 5/16"	49	1	S 41657 00 01	Spring stripper arm W46
22	1	S 65754 00 02	Disconnect rod 60	50	1	S 65747 00 19	Peeler W60 Rewind
23	1	S 65753 00 04	Pawls carrier Ø8xN2*	51	1	S 66578 00 80	Spacer ring Winch 60*
24	1	S 65752 00 41	Gear Z23	52	1	S 65761 00 41	Tapered spacer for W60 drum
25	1	S 65751 00 04	Main shaft W60	53	8	S385970001	Spring*
26	1	S 41626 00 41	Disconnect flange	54	1	S 41436 00 A9	Upper Jaw W60
27	2	M 06141 03	Ball 5-16" inox	55	1	S 65749 00 53	Lower Jaw W60
28	1	M0616603	Seeger Ring UNI 7435:1975 - Ø28 mat. 17-7 Ph				

\*Service kit available; see winch kit section on the website [www.harken.com](http://www.harken.com)

\*\*Winch product sticker



**Radial® 60 STCW Rewind™ Winch (White Line)**

Pos.	Q.ty	Code	Description	Pos.	Q.ty	Code	Description
1	1	A 967608 00 W	Assy Base W60 RAL 9003 (for White Line)**	29	1	M 06308 02	SMALLEY RING SSR0137-S17
2	1	S 65755 00 04	Gear Z14 W60	30	1	A 765756 00	Command x W60
3	6	S 00008 00 03	Pawl Ø8*	31	1	A 965757 00	Assy knob W60
4	6	S 00038 00 01	Pawl Spring dia 8*	32	1	S 49740 00 80	Knob W46
5	1	S278170002	Washer 12.5x48x1.5*	33	1	S 65759 00 80	Swich Support W60
6	1	S281010004	Pin for gear	34	1	M6009463	Spring loaded ball plunger Ø6*
7	1	S 41442 00 41	Rachet Gear Z26xN4	35	2	M 06446 03	Hex key M5x20 UNI 5931*
8	1	S 41441 00 04	Pawls Carrier Gear Z13 N4	36	1	S 41653 00 04	Pin for switch W46
9	2	A72821800	Roller Bearing 14/20/18*	37	1	M 06242 03	Screw M6x30*
10	1	S 41603 00 04	Gear Pin Ø12xØ18x52,5	38	1	A 941652 00	Assy socket W46
11	1	S 41448 00 04	Idler and Pinion Z23/Z13 W60	39	1	M0624103	Screw M4x16 UNI5933*
12	2	A 741623 00	Roll bearing 24x18x18*	40	1	S 41859 00 01	Spring Ø10.67x12.7 rif.SPEC C0420-035-0500S*
13	1	A 941431 00	Assy Housing Winch 60 <i>Winch Serial Number Sticker</i>	41	1	S 65762 00 52	Spacer for stripperarm support W60*
14	6	M0606303	Screw M8x25 UNI 5931*	42	3	S 41875 00 03	Screw M6x50 U6107 Teflon Coating*
15	3	A 741450 00	Roller Bearing Ø95xØ107x26*	43	4	M0623103	Screw M6x40 TC DIN84 A4*
16	1	S 41876 00 63	Winch Serial Number Sticker	44	4	M 06017 03	Screw M6x25 UNI 5931*
17	1	S 41443 00 A0	Stripper Arm Housing W60	45	1	S 41917 00 80	Slider
18	1	S 28170 00 97	Red line	46	2	M 06190 03	Screw M5x20 UNI 6109*
19	1	S 65748 00 B1 W	Cover 2 Speed W60 RAL 9003 (for White Line)	47	1	S 41658 00 41	Bushing
20	1	A 766457 00	Drum Assembly W60	48	1	S 65746 00 03	Stripper-arm W60
21	50	M 06102 80	Ball 5/16"	49	1	S 41657 00 01	Spring stripper arm W46
22	1	S 65754 00 02	Disconnect rod 60	50	1	S 65747 00 19	Peeler W60 Rewind
23	1	S 65753 00 04	Pawls carrier Ø8xN2*	51	1	S 66578 00 80	Spacer ring Winch 60*
24	1	S 65752 00 41	Gear Z23	52	1	S 65761 00 41	Tapered spacer for W60 drum
25	1	S 65751 00 04	Main shaft W60	53	8	S385970001	Spring*
26	1	S 41626 00 41	Disconnect flange	54	1	S 41436 00 A9 W	Upper Jaw W60 RAL 9003 (for White Line)
27	2	M 06141 03	Ball 5-16" inox	55	1	S 65749 00 53	Lower Jaw W60
28	1	M0616603	Seeger Ring UNI 7435:1975 - Ø28 mat. 17-7 Ph				

\*Service kit available; see winch kit section on the website [www.harken.com](http://www.harken.com)

\*\*Winch product sticker





Horizontal electric motor 12V

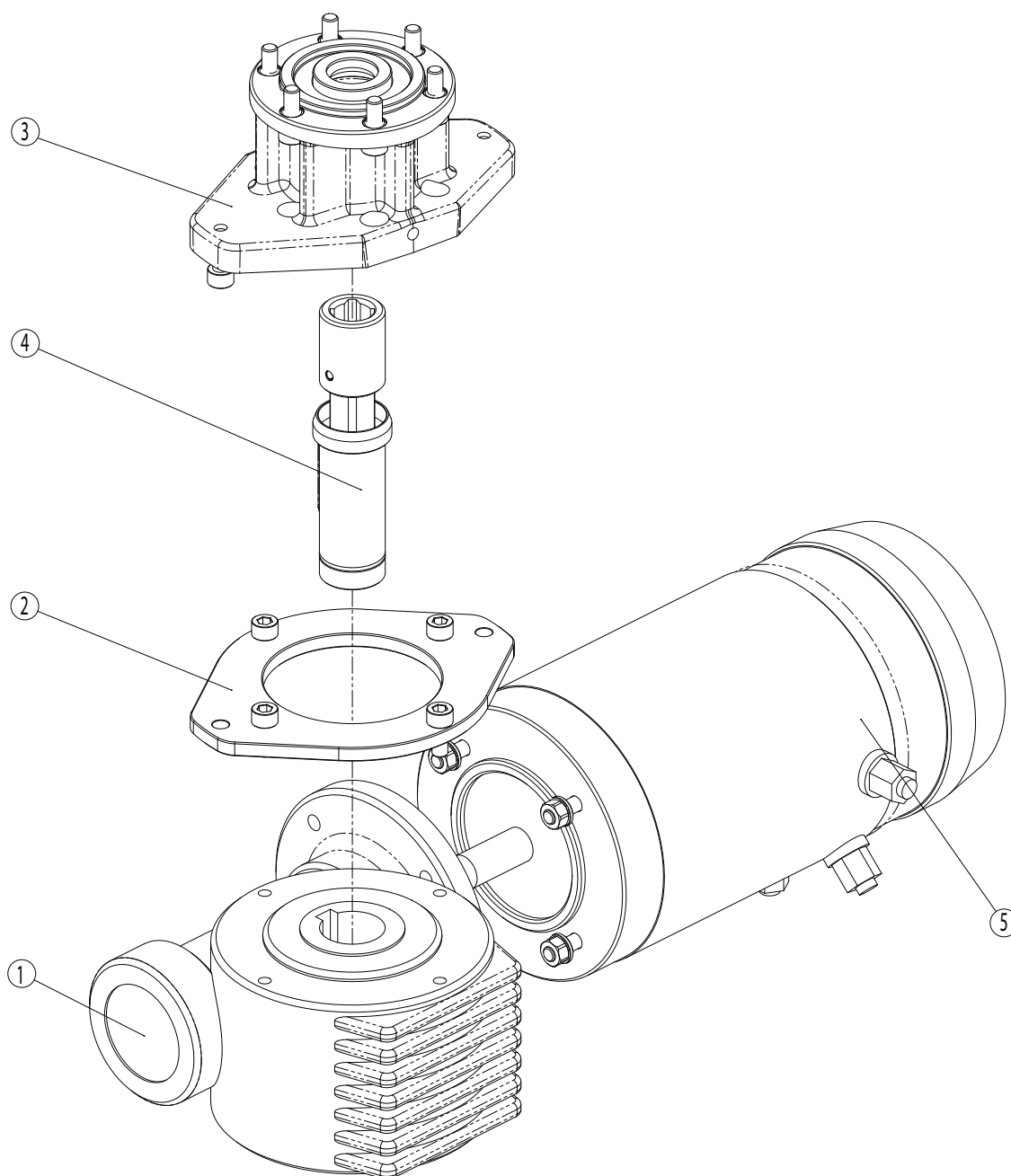

**TOP VIEW**

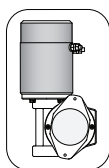

**\* Motor installed in right-hand configuration.**

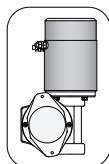

**\*\* Motor installed in left-hand configuration.**

Pos.	Qty	Code	Description
1	1	A 931279 00	KIT Gear Reduction VF49*
		A 941949 00	KIT LM Gear Reduction VF49**
2	1	A 941492 00	KIT Assy Electric Motor Flange
3	1	A 949665 00	KIT EL HO Motor Flange
4	1	A 965890 00	KIT EL HO Motor Clutch
5	1	A 966568 00	Motor 12 V 1.5 kW

Horizontal electric motor 24V

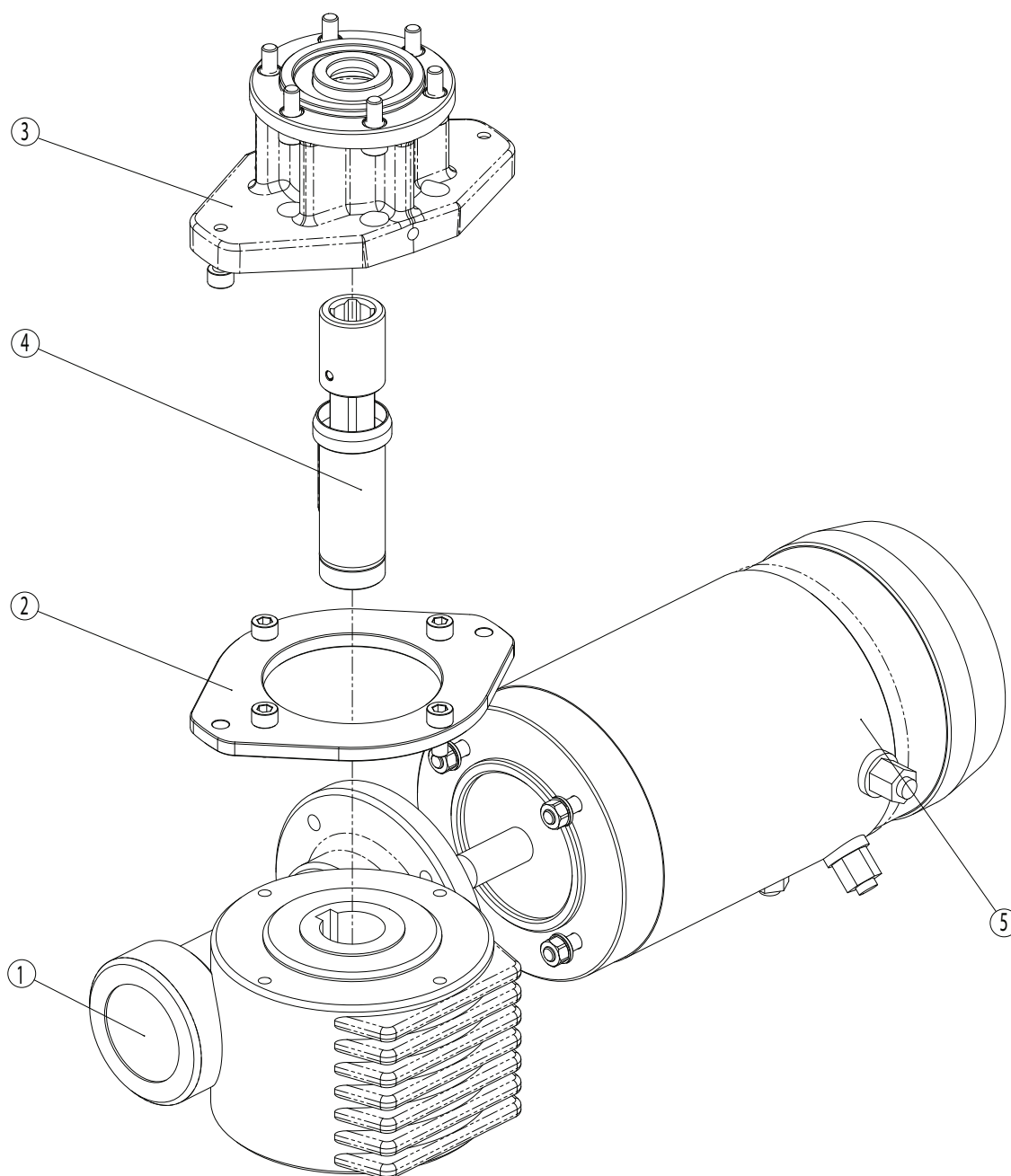

**TOP VIEW**

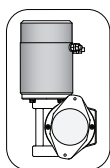

**\* Motor installed in right-hand configuration.**

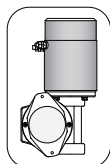

**\*\* Motor installed in left-hand configuration.**

Pos.	Qty	Code	Description
1	1	A 931279 00	KIT Gear Reduction VF49*
		A 941949 00	KIT LM Gear Reduction VF49**
2	1	A 941492 00	KIT Assy Electric Motor Flange
3	1	A 949665 00	KIT EL HO Motor Flange
4	1	A 965890 00	KIT EL HO Motor Clutch
5	1	A 966569 00	Motor 24 V 2 kW