23920 SERIES

RUN DRY UTILITY PUPPY 2000 & 3000 FLEXIBLE IMPELLER PUMP



a xylem brand

1. INTRODUCTION

ATTENTION



It is essential that anyone who will install, operate, service/maintain or be involved with this pump shall read the whole of this manual before pump installation, operation or servicing/maintenance, as it contains important safety information. Failure to follow these instructions could result in damage to the pump, equipment, or injury to yourself or other people. Adherence to the procedures and specifications outlined in the following chapters will assist in providing economical and reliable operation throughout the life of the pump. If service or repair other than that described in this manual should become necessary, contact your supplier for assistance. Any pump returned to the supplier for any reason must be fully cleaned and decontaminated and accompanied by details of what fluids have been pumped, including full Health and Safety information (SDS sheets) if any of those fluids are hazardous. **DO NOT USE THIS PUMP TO TRANSFER LIQUIDS WITH A FLASH POINT BELOW 100°F (37°C) OR USE WHERE FLAMMABLE VAPORS ARE PRESENT.**

The 23920 Series self-priming Jabsco Flexible impeller pump is of bronze pump head, nitrile flexible impeller, lip seal (2000 model) and mechanical shaft seal (3000 model) construction powered by a 12V or 24V DC motor for marine, domestic and industrial applications, where short duration over running without flow is a possibility. The ability to handle solids and robust construction suits marine/domestic waste discharge (including bilge discharge), aqueous industrial fluid transfer and ability to handle other fluids compatible with construction materials. The pump is designed to be powered from fully charged batteries or other DC supply with adequate amperage provision. Pump connections are BSP/NPT thread, the pump being designed to operate with 1" reinforced hose. Dependent on system pressures, flows up to 29.5 litres per minute at 3m H₂O (2000 model) and 40 litres per minute at 3m H₂O (3000 model) can be expected with flow declining as differential pressure across the pump increase. The pump will reliably operate where differential pressures are at or below 6m H₂O (2000 model) or 12m H₂O (3000 model). The dry running feature means the pump is not reversible, the discharge being the vertical port. The pump comes with 250mm long electrical connecting leads (2000 model AWG14 or 2mm²; 3000 model AWG12 or 3.3mm²).

2. SAFETY

Please keep this manual carefully and available to all operators. Do not ignore safety instructions. Throughout this manual your attention is drawn to certain procedures which must be followed to ensure safe operation and servicing of this product.



ATTENTION

- Failure to observe the recommended safety procedures can lead to material damage.
- Do not use the pump if the end cover is removed, custom fitted guards are missing or inlet & outlet pipework is not connected.
- Do not forget the hazards of moving parts, high fluid pressure, extremes of temperature, hazardous liquids and electricity.
- Do not use the pump with fluids of flash point below 37°C
- Always isolate and lock-out the pump before inspecting or servicing pump.
- Only qualified Service personnel should attempt to repair / service the pump. Only use Original Equipment Manufacturer's Parts and Accessories.
- Do not run the pump without suitable supervision as established for safe working practices and company procedures.
- Not to be used by children and non-authorized personnel.
- Always follow good working practice when using this equipment.
- Follow legislation applicable to your areas of operation.
- Do not touch the motor surface during or after operation of the pump as the surface can become hot.
- The appliance is not to be used by children or persons with reduced physical, sensory or mental capabilities, or lack of experience and knowledge. Cleaning and user maintenance shall not be made by children unless they have been given supervision or instruction.
- Children not being supervised should not play with the appliance.
- **WARNING:** all marine pumps discharging overboard must be installed with overboard discharge well above static and heeled waterlines. Flooding and death may occur.
- California Proposition 65 warning: This product may contain a chemical known to the State of California to cause cancer birth defects or other reproductive harm.
- The equipment is not spark, flame or explosion proof and has not been designed for use in hazardous areas in terms of the ATEX Directive 2014/34/EU.
- Use recommended fuses

3. OPERATING CONDITIONS

The pumps are designed using modern design techniques and manufactured from high quality materials. However, there are certain limitations to the operating conditions of the pump to ensure long life and trouble-free running. During pump selection and specification these limitations must be taken into account and not be exceeded.

- Ambient working temperature -5°C/23°F to 60°C/140°F
- All pump models are rated to handle pumped fluid temperatures: 10°C (50°F) to 90°C (194°F)
- Maximum suggested viscosity is 1000cP but care with pipe losses is required
- Maximum prime height is 1.2m (4ft) for 2000 model and 2.4m (8ft) for 3000 model
- No leaks or blockages should be in the system. Inlet leaks will degrade self-priming capability
- Initial pump priming must not last longer than 30s before fluid enters the pump head providing impeller lubrication
- After initial prime and with flooded pump head, run dry duration is 20 minutes (2000 model) and 10 minutes (3000 model)
- Do not restrict the inlet pipework. Flexible impeller pumps can handle solids so strainers are not generally recommended
- Do not exceed differential pressures; 6m H₂O (2000 model) or 12m H₂O (3000 model). Keep pipe runs straight and short to minimize pipe losses.
- Hard and soft Solids handling should present little or no problem for the pump with solids size below approx. 6-7mm

4. INSPECTION UPON RECEIPT

- Check the pump for any physical damage sustained in shipping.
- If loss or damage is found, notify your carrier and supplier immediately.
- Remove packing material from container and check the pump label for voltage and part number

Model series and pump part numbers

Part No	Model		Thread		Voltage	
	2000	3000	BSP	NPT	12V	24V
23920-2223		X	X		X	
23920-2323		X	X			X
23920-9223		X		X	X	
23920-9323		X		X		X
23920-2423	X		X		X	
23920-2523	X		X			X
23920-9423	X			X	X	
23920-9523	X			X		X

5. INSTALLATION

Model	Voltage (V)	Overall Height mm (inch)	Overall Length mm (inch)	Overall Width mm (inch)	Weight kg (lb)	Ports	Flow @3m head l/min (USGPM)	Max head (mH ₂ O)	Min Wire Size mm ² (SWG)	Max. length of wire between (+) & (-) Battery Terminals M (Ft)	Output (W)	Fuse (A)
23920-2223	12	110 (4 5/16)	216 (8 1/2)	124 (4 7/8)	3.9 (8.6)	3/4" BSP	44 (11.6)	12	6 (8)	4.5 (15)	252	25
23920-2323	24	110 (4 5/16)	216 (8 1/2)	124 (4 7/8)	3.9 (8.6)	3/4" BSP	44 (11.6)	12	4 (10)	4.5 (15)	264	15
23920-9223	12	110 (4 5/16)	216 (8 1/2)	124 (4 7/8)	3.9 (8.6)	3/4" NPT	44 (10.6)	12	6 (8)	4.5 (15)	252	25
23920-9323	24	110 (4 5/16)	216 (8 1/2)	124 (4 7/8)	3.9 (8.6)	3/4" NPT	44 (11.6)	12	4 (10)	4.5 (15)	264	15
23920-2423	12	110 (4 5/16)	179 (7 1/16)	124 (4 7/8)	3.3 (7 1/3)	3/4" BSP	29.5 (7.8)	6	1.5 (14)	4.5 (15)	156	15
23920-2523	24	110 (4 5/16)	179 (7 1/16)	124 (4 7/8)	3.3 (7 1/3)	3/4" BSP	29.5 (7.8)	6	1.5 (14)	4.5 (15)	180	10
23920-9423	12	110 (4 5/16)	179 (7 1/16)	124 (4 7/8)	3.3 (7 1/3)	3/4" NPT	29.5 (7.8)	6	1.5 (14)	4.5 (15)	156	15
23920-9523	24	110 (4 5/16)	179 (7 1/16)	124 (4 7/8)	3.3 (7 1/3)	3/4" NPT	29.5 (7.8)	6	1.5 (14)	4.5 (15)	180	10

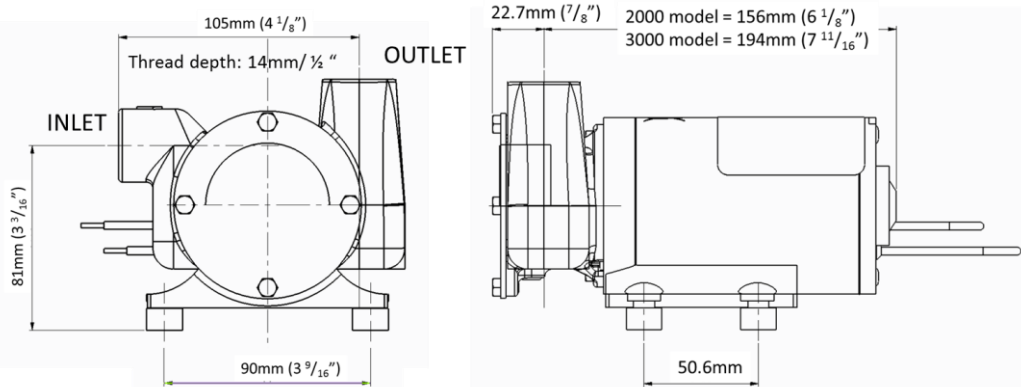

NB Imperial dimensions are derived from metric equivalents. Minor Discrepancies may exist

Pump Setup

Jabsco Utility Puppies can be mounted on any flat surface. Fit the pump in a dry, well ventilated position where there is full access for service. If installed in the vertical position, the motor must be above the pump head. Use the rubber grommets provided to minimize vibration. M6x25 screws, M6 nuts and M6 washers to BS4320 form A are suggested. Do not over tighten the mounting screws.

Dependent on model, 3/4" BSP or NPT threaded hose connectors should be used to connect 1" (25.4mm) inlet and outlet hoses. Secure the hose to the fitting with stainless steel hose clamps. Use spiral reinforced hose (with a smooth internal bore) that will not collapse under suction, or ridged or semi ridged pipework. The pipework must be compatible with the liquid being pumped. Pipe runs should be kept as straight and short as possible. For BSP models, Jabsco 3/4" BSP thread fitting part number 23543-1200 with bonded washer SP1613-1415 can be used.

When considering longer pipe runs, ensure the overall pump differential pressure is not exceeded due to pipe losses and static heads. Ensure priming heights are within the pump capability and included in pipe loss calculations. Keep the inlet pipe run short, placing the pump as close to the feed fluid as is practicably possible

Electrical Setup



ATTENTION

- All electrical installation must be installed according to national wiring rules. Ensure only the correct rated fuses are fitted. Please refer to the Pump specification Table in section 5 for a suitable size fuse that must be fitted to ensure the safety of product. Check the voltage on the pump data label
- Wire the pump to a DC source of correct voltage and adequate amperage capacity
- Make all electrical connections in dry locations. Connections in humid environments should be sealed to prevent corrosion.
- Protect the circuit with a correctly sized fuse or circuit breaker in the positive (+) lead as close as possible to the

power source. Select the correct cable size from the chart above. Inadequate voltage at the terminals when the pump is running (less than 10% below rated voltage at full load) due to partially discharged batteries or insufficient cable size may result in blowing fuses, failure to start or poor pump performance.

- The pump may be switched manually, via a relay or automatically via a float switch. Only use switching gear of adequate power rating and position after the fuse.
- Connections made should use insulated spade and blade connectors or equivalent robust connection capable of handling the fuse rated current.

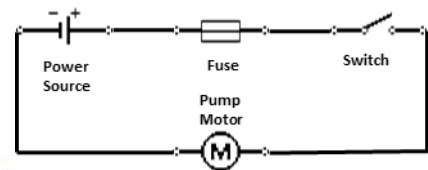

ATTENTION

Connecting wire lengths may be extended beyond the standard recommendations above. The following considerations should be made by qualified personnel when selecting suitable wire diameter

- Voltage drops occur over long wire runs. Ensure these voltage drops do not exceed the recommended 10% from rated voltage drop.
- As a guideline, the voltage drop E, at load, in volts may be calculated by the following formula:

$$E = \frac{0.0164 \times I \times L}{S}$$

Where S is the cross-sectional area of the conductor in square millimetres; I is the load, in amperes; L is the length, in metres, of the conductor from the positive power source to the pump motor and back to the negative source connection.

6. PRODUCT OPERATION

Permitted Fluids



ATTENTION

DO NOT USE WITH LIQUIDS WITH A FLASH POINT BELOW 100°F (37°C) OR USE WHERE FLAMMABLE VAPORS ARE PRESENT.

- Ensure operating conditions are in line with section 3 before initial and primed starting of pump.

Initial Start-Up

- Complete the installation.
- Check the inlet pipework is in contact with fluid to be pumped
- Do not run the pump dry for more than 30 seconds
- Do not operate any switches with wet hands

Primed Start-Up

- Check the inlet pipework is in contact with fluid to be pumped
- Do not operate any switches with wet hands
- With flooded pump head, run dry duration is 20 minutes (2000 model) and 10 minutes (3000 model) Do not exceed these durations

Storage and Cleaning

- Should viscous or potentially aggressive fluids be pumped, it is recommended the pump be cleaned internally after each use.
- If the pump needs to be removed for storage purposes, it must be stored in a cleansed condition in a cool dry location.
- If storage is for longer than 3 months, a suggestion is to remove the impeller. This will prevent a set being taken and improve performance at startup
- If storage is over a year, using a new impeller will guarantee specified performance.
- Pump units have been designed to meet IP55 standards and can be pressure washed. Care should nevertheless be taken to prevent wetting exposed electrical connections
- Winterization – Remove the impeller, ensure pump and system is thoroughly drained for winterization to prevent freezing ice damage from occurring to pump and system.

Performance

In addition to poor installation and operating conditions, the following conditions will degrade performance and should be avoided:

- Leaks in inlet pipework - will degrade pump priming
- Over pressurization of the pump – typically, impeller blades will be seen to break half way down their length
- Dry running – typically impeller blades tear unevenly, break at the impeller hub and there is a blacking internally on the end cover and impeller body bore
- Chemical attack – impeller swells and loses shape

Utility Puppy 2000 Performance			
Typical performance for new pump running water at 20C with fully charged battery.			
Total head		Flow	
m	ft	lpm	USgpm
2	7	32	8.5
3	10	29.5	7.8
4	13	26	6.9
6	20	22	5.8

Utility Puppy 3000 Performance			
Typical performance for new pump running water at 20C with fully charged battery.			
Total head		Flow	
m	ft	lpm	USgpm
3	10	44	11.6
6	20	38	10
9	30	32	8.5
12	40	25	6.6

7. MAINTENANCE, SERVICE & CUSTOMER REPAIR

The pumps are designed to require minimal amounts of maintenance.

However it is recommended as good practice to:

- Check hose connections are secure once a month
- Check the electrical connectors and cables are in good condition once a month
- Check the condition of the impeller every 100hours operation and replace every 12 months or when degraded performance is evident. It is recommended the end cover O ring is replaced at the time of impeller replacement
- Lip seals should be replaced every 800 hours or when seal leaks occur – Use Service kit SK415-0003
- Mechanical seals should be replaced every 3500 hours or when seal leaks occur. – Use Service kit SK415-0113
- Note that motors are not serviceable.

Pump disassembly and assembly

Parts list (model 2000)

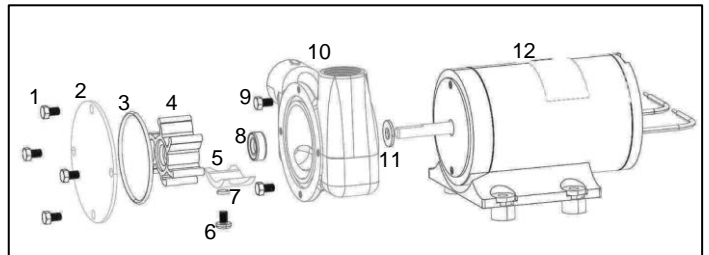

Description	Quantity	Part number	Key
*End cover screw	*4	*X3001-147F	1
End cover	1	23825-0000	2
End cover seal	1	*X4020-257A	3
Impeller	1	6303-0003	4
CAM	1	53023-0100	5
*CAM screw	*1	*X3002-147F	6
*CAM screw seal	*1	*X4020-105A	7
*Lip Seal	*1	*SP2701-52	8
Pump/Motor Screws	2	X3001-147F	9
Pump Body (NPT)	1	53024-9100	10
Pump Body (BSP)	1	53024-2100	10
Slinger 2000	1	6342	11
Motor (12V)	1	98012-2652C	12
Motor (24V)	1	98012-2653C	12
*Service Kit		SK415-0003	

Disassembly Instructions common to 2000 and 3000 models:
To disassemble the pump, Ensure power is isolated from the pump. Ensure pipework is drained of fluid. Disconnect physical and electrical connections. Remove the 4 off end cover M5 screws using an 8mm (5/16") spanner. Remove the end cover and end cover O ring. Clean these parts removing deposits and scum build up. Remove the impeller. The impeller should come out easily manually. If encouragement is required, long nose pliers can be used to grip the impeller hub to aid removal. Check the impeller sides and blade tips for signs of wear; check the blades are all present and free of cracks, tears, distortion. Replace the impeller if imperfect. Note an impeller will take set over time if not regularly used. This is not important to the performance of the pump and set can be alleviated by placing the impeller in hot water for five or so minutes. The Cam regulates flow. It can wear but usually only over many hundreds of hours use. It will normally not require replacement. If the cam does wear, a reduction in flow will be seen. To remove the Cam, undo the slot head screw at the base of the body. Remove the screw and its accompanying small sealing O ring. The Cam then comes away from inside the pump body. Clean up the Cam, Cam screw and O ring

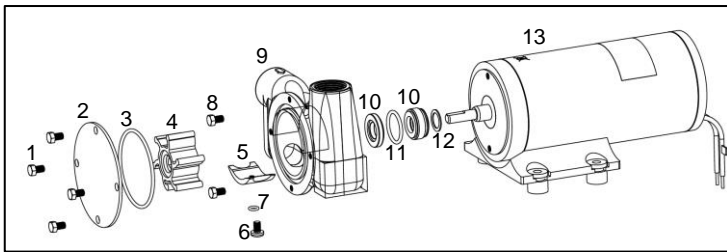

Parts list (model 3000)

Description	Quantity	Part number	Key
*End cover screw	*4	*X3001-147F	1
End cover	1	23825-0000	2
*End cover seal	*1	*X4020-257A	3
*Impeller	*1	*7273-0003	4
CAM	1	53023-0100	5
*CAM screw	*1	*X3002-147F	6
*CAM screw seal	*1	*X4020-105A	7
*Pump/Motor Screws	*2	*X3001-147F	8
Pump Body (NPT)	1	53024-9000	9
Pump Body (BSP)	1	53024-2000	9
*Mechanical Seal (static)	*1	*SP8021-0301B	10
*O ring Slinger	*1	*X4020-221B	11
Mechanical Seal (Dynamic)	1	Part of SP8021-0301B	10
Support washer	1	X5263-002	12
Motor (12V)	1	98012-0161C	13
Motor (24V)	1	98012-0162C	13
*Service Kit		SK415-0113	

Disassembly specific to 2000 lip seal model:

To avoid inducing leaks, remove the lip seal from the body only if being replaced. To remove the seal from the body seal bore, remove the pump body from the motor by loosening and removing the 2 off M5 screws using an 8mm (5/16") spanner. With the body removed, manually press the lip seal out the front of the body seal bore. Alternatively the lip seal can be removed from the front of the body using a small screwdriver to pry out the seal from the seal bore. Ensure not to scratch the seal bore with the screwdriver as this will create a leak path for the fluid to escape the pump. With the body removed, the slinger can be accessed and removed. This component deters any leaking fluid from entering the motor; a small but important part of the pump. Replace it if perished or it no longer grips the shaft. Clean the body and slinger before re-assembly. Component cleaning should be done with soap and water. Do not clean elastomers with solvents.

Disassembly specific to 3000 mechanical seal model:

To avoid inducing leaks, remove the mechanical seal from the pump only if being replaced. To remove the seal from the pump, remove the pump body from the motor by loosening and removing the 2 off M5 screws using an 8mm (5/16") spanner. On removal, the static face of the seal (white ceramic) will be left in the body, the dynamic face of the seal (metal encased carbon) will be on the shaft. Press the static face out the back of the body, taking care not to scratch the seal bore. The O ring on the dynamic metal case circumference is the slinger. Remove the slinger. Slide off the dynamic seal face. Whilst inspecting the mechanical seal faces, take care not to touch, scratch or otherwise damage the shiny lapped seal surfaces. If the seal leaks, look for radial grooves, large chips or scratches traversing in the carbon seal face. Also look for effective grip of the elastomer on the shaft. If no fault can be found, the leak may not be from the mechanical seal. Finally remove the plastic Support washer. The support washer optimizes the mechanical seal function and is an important part of the design.

Reassemble the pump in the reverse order to the disassembly.

Specific to 2000 lip seal model

Position the slinger to within 4mm (3/16") of the motor end cover. Press the lip seal ("closed" face first) into the pump body seal bore. Ensure it is fully seated. Lubricating with soapy water may help seating. Do not use grease.

Specific to 3000 mechanical seal model:

Place the support washer over the motor shaft and rest against the motor bearing. Place the O ring slinger centrally over the dynamic

seal face metal casing and slide that over the motor shaft to sit against the support washer. Push the static seal face fully into the body seal bore. The above two actions will be eased using soapy water as a lubricant. Do not use grease. Ensure the seal faces are clean and free of debris, grit and other contaminants which will cause the seal to leak.

Secure the pump body to the motor by fitting and tightening the 2 off M5 screws using an 8mm (5/16") spanner. Tighten to 3.7-4.2Nm (2.7-3.1ftlb). Secure the Cam to the body with cam screw and O ring. Tighten to 3.7-4.2 Nm (2.7-3.1ftlb). Do not over tighten as this will potentially cause leaks due to over compression of the O ring. The impeller hub single flat mates with the shaft single flat. Lubricate the impeller and body impeller bore with Jabsco impeller lubricant 43000-0802 (lubricant and end cover O ring included in impeller kit 6303 & 7273-0003-P). Insert the impeller using a clockwise twisting movement. Place the end cover O ring into the body O ring groove. Smearing the O ring with lubricant helps keep it in place whilst the end cover is fitted. Secure the end cover to the body with the 4 off end cover M5 screws using an 8mm (5/16") spanner. Tighten to 3.7-4.2 Nm (2.7-3.1ftlb). Re-install to the system secure electrical and physical connections and follow the "initial startup procedure" detailed above

8. CUSTOMER SUPPORT

- If any pump units for any reason need to be returned, please ensure the pump unit has been fully drained before returning. Please contact customer services for more information

9. ENVIRONMENTAL PROTECTION



Due consideration to environmental issues have been made within the design and manufacturing process of this product without compromising product performance and value.

WEEE Policy

The Waste Electrical and Electronic Equipment Directive (WEEE Directive) is a European Community Directive 2012/19/EU on waste electrical and electronic equipment which became European Law in February 2003. The

WEEE Directive set collection, recycling and recovery targets for all types of electrical goods.

Xylem Water Services Limited has identified that their product range comes under Category 6 (Electrical tools) and as such will undertake their responsibilities in line with the above directive and will fulfill their legal obligation by means of joining a compliance scheme. All products are identified by means of the Wheelie bin logo as laid down in the above directive.

The Xylem Water Services Limited WEEE producer registration number is **WEEE/RM07081**

Full details of scheme can be found @ Valpak Limited Unit 4, Montague House, Stratford-upon-Avon Business and Technology Park, Banbury Road, Stratford-upon-Avon, At the end of your product and accessories life, it must not be discarded as domestic waste.

Please contact your distributor / supplier for further information. For end users outside of the EU consult applicable regulations. This product should only be dismantled for recycling by an authorized recycling company.

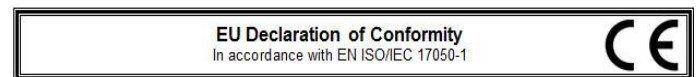

EU Declaration of Conformity			
In accordance with EN ISO/IEC 17050-1			
Equipment/Model number:	23920-XXXX	Utility Puppy 2000 / 3000 Bronze DC Pump	
Product Name:	23920 SERIES		
	23920-2423	2000 Bronze 12 (Vdc) 15 (amp)	3/4" BSP
	23920-2523	2000 Bronze 24 (Vdc) 10 (amp)	3/4" BSP
	23920-9423	2000 Bronze 12 (Vdc) 15 (amp)	3/4" NPT
	23920-9523	2000 Bronze 24 (Vdc) 10 (amp)	3/4" NPT
	23920-2223	3000 Bronze 12 (Vdc) 25 (amp)	3/4" BSP
	23920-2323	3000 Bronze 24 (Vdc) 15 (amp)	3/4" BSP
	23920-9223	3000 Bronze 12 (Vdc) 25 (amp)	3/4" NPT
	23920-9323	3000 Bronze 24 (Vdc) 15 (amp)	3/4" NPT

Is in conformity with the applicable requirements of the following documents:

DIRECTIVE	STANDARDS
2014/30/IEC Electromagnetic Compatibility	IEC 60945:2002 Maritime navigation and radio communication equipment and systems. General requirements. Methods of testing and required test results ISO 8846:1990
2013/53/EU Recreational Craft Directive	Small Craft- Electrical devices Protection against ignition of surrounding flammable gases ISO 8846:1990 Small craft- Electrically operated direct-current bilge pumps
2011/65/EU Restriction of Hazardous Substances (RoHS)	

11. WARRANTY

XYLEM LIMITED WARRANTY WARRANTS THIS PRODUCT TO BE FREE OF DEFECTS AND WORKMANSHIP FOR A PERIOD OF 2 YEARS. THE WARRANTY IS EXCLUSIVE AND IN LIEU OF ANY AND ALL OTHER EXPRESS OR IMPLIED WARRANTIES, GUARANTEES, CONDITIONS OR TERMS OF WHATEVER NATURE RELATING TO THE GOODS PROVIDED HEREUNDER, INCLUDING WITHOUT LIMITATION ANY IMPLIED WARRANTIES OF MERCHANTABILITY AND FITNESS FOR A PARTICULAR PURPOSE, WHICH ARE HEREBY EXPRESSLY DISCLAIMED AND EXCLUDED. EXCEPT AS OTHERWISE PROVIDED BY LAW, BUYER'S EXCLUSIVE REMEDY AND SELLER'S AGGREGATE LIABILITY FOR BREACH OF ANY OF THE FOREGOING WARRANTIES ARE LIMITED TO REPAIRING OR REPLACING THE PRODUCT AND SHALL IN ALL CASES BE

LIMITED TO THE AMOUNT PAID BY THE BUYER HEREUNDER. IN NO EVENT IS SELLER LIABLE FOR ANY OTHER FORM OF DAMAGES, WHETHER DIRECT, INDIRECT, LIQUIDATED, INCIDENTAL, CONSEQUENTIAL, PUNITIVE, EXEMPLARY OR SPECIAL DAMAGES, INCLUDING BUT NOT LIMITED TO LOSS OF PROFIT, LOSS OF ANTICIPATED SAVINGS OR REVENUE, LOSS OF INCOME, LOSS OF BUSINESS, LOSS OF PRODUCTION, LOSS OF OPPORTUNITY OR LOSS OF REPUTATION. THIS WARRANTY IS ONLY A REPRESENTATION OF THE COMPLETE LIMITED WARRANTY. FOR A DETAILED EXPLANATION, PLEASE VISIT US AT www.xylemflowcontrol.com/support/, CALL OUR OFFICE NUMBER LISTED, OR WRITE A LETTER TO YOUR REGIONAL OFFICE

Xylem |'zīləm|

- 1) The tissue in plants that brings water upward from the roots;
- 2) a leading global water technology company.

We're a global team unified in a common purpose: creating innovative solutions to meet our world's water needs. Developing new technologies that will improve the way water is used, conserved, and re-used in the future is central to our work. We move, treat, analyze, and return water to the environment, and we help people use water efficiently, in their homes, buildings, factories and farms. In more than 150 countries, we have strong, long-standing relationships with customers who know us for our powerful combination of leading product brands and applications expertise, backed by a legacy of innovation.

For more information on how Xylem can help you, go to www.xyleminc.com

CHINA

32/F Tower A. Hongqiao City
Centre of Shanghai
100 Zunyi Road
Tel +86 21 2208 2888
Fax +86 21 2208 2999
www.xylemflowcontrol.com

GERMANY

Deutschland GmbH
Oststrasse 28
22844 Norderstedt
Tel +49.(0)40 53 53 730
Fax +49.(0)40 53 53 7311
www.xylemflowcontrol.com

ITALY

Via Tommaseo, 6,
20059 Vimercate,
Milano,
Tel +39 0039 685 2323
Fax +39 0039 666 307
www.xylemflowcontrol.com

UNITED STATES

SA - West Coast
17942 Cowan
Irvine, CA 92614
Tel +1.949 608 3900
Fax +1.949 608 3888
www.xylemflowcontrol.com



Xylem, Inc.
Bingley Road, Hoddesdon
Hertfordshire, EN11 0BU
United Kingdom
Tel +44 (0)1992 450145
Fax +44.(0)1992 4671332
www.xyleminc.com

Flojet is a trademark of Xylem Inc. or one of its subsidiaries.

