

Ispire

Ispire Technology, Inc.
(NASDAQ: ISPR)

Management Presentation

September 2023

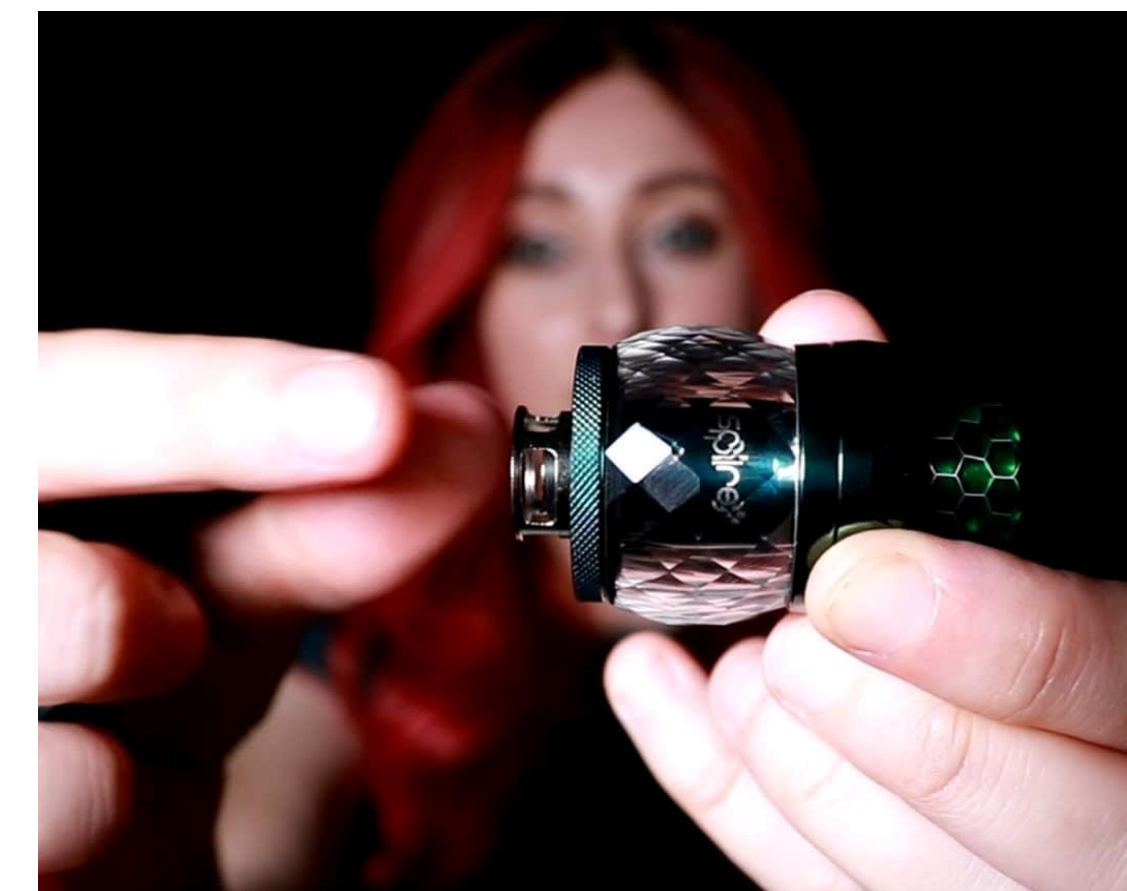
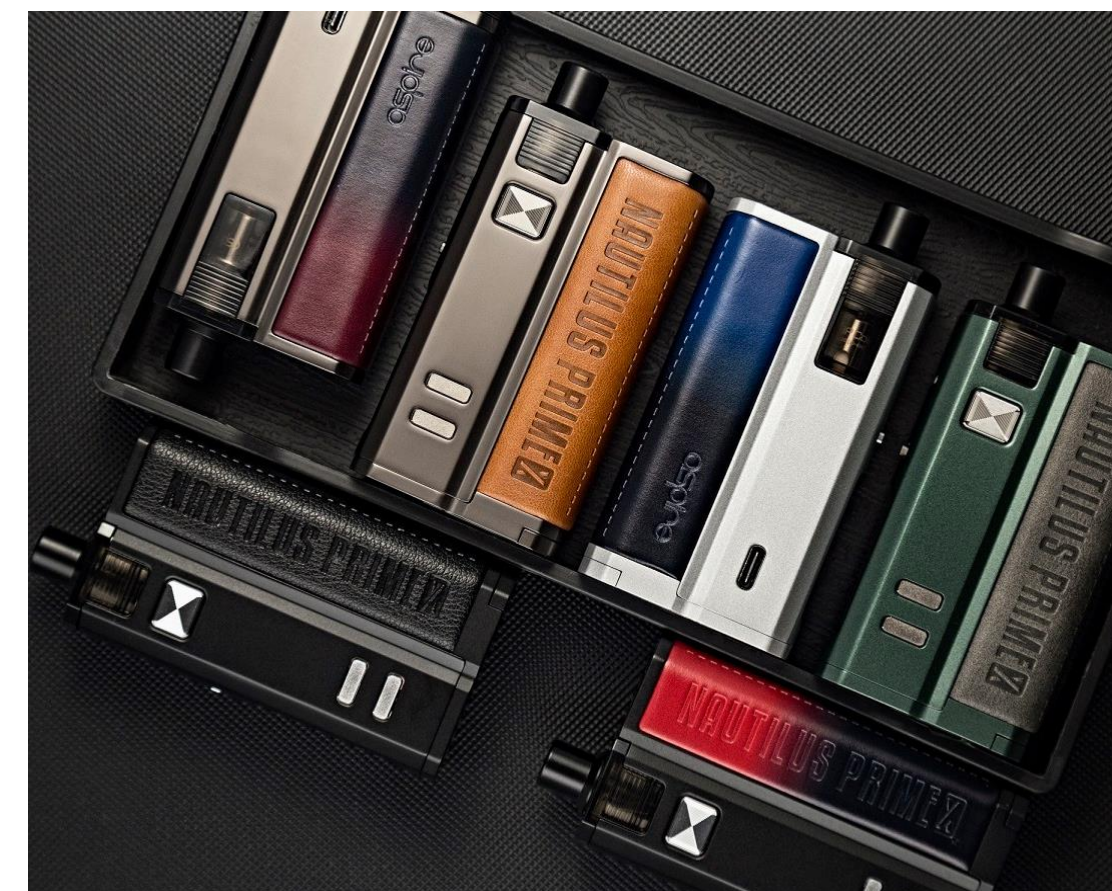
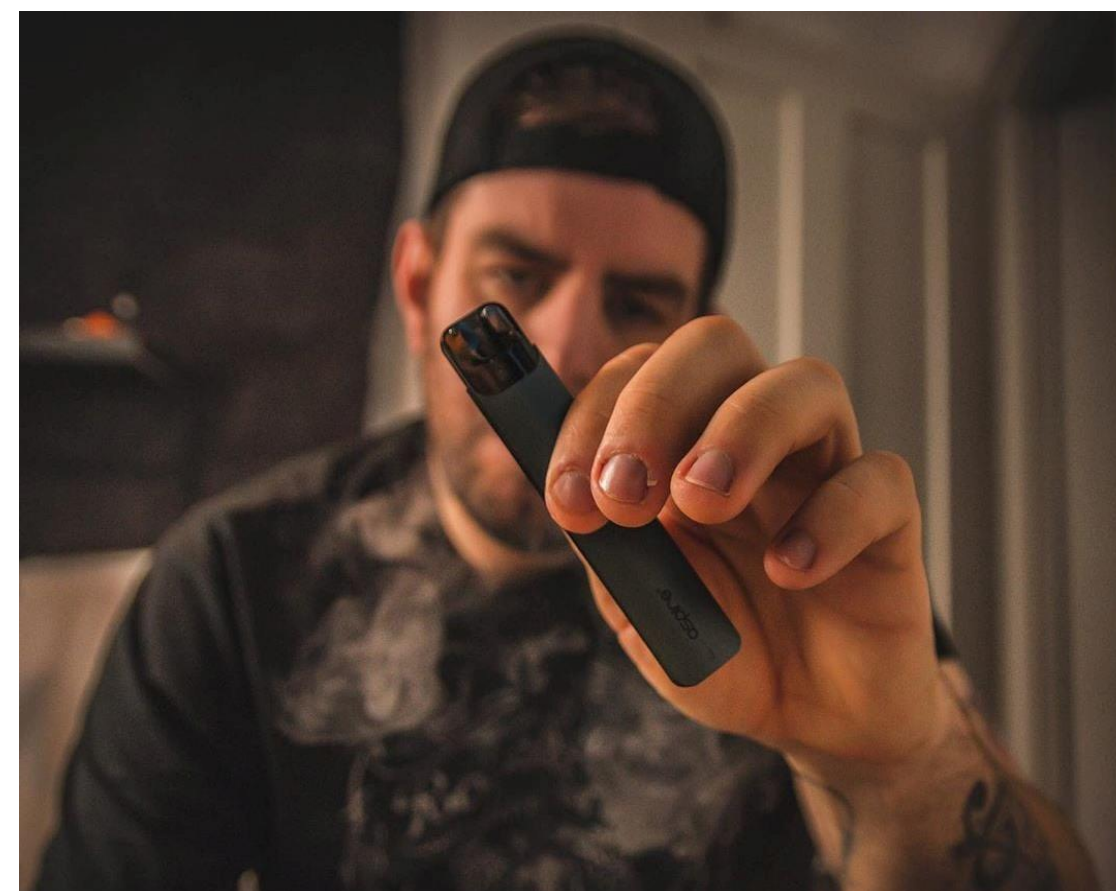
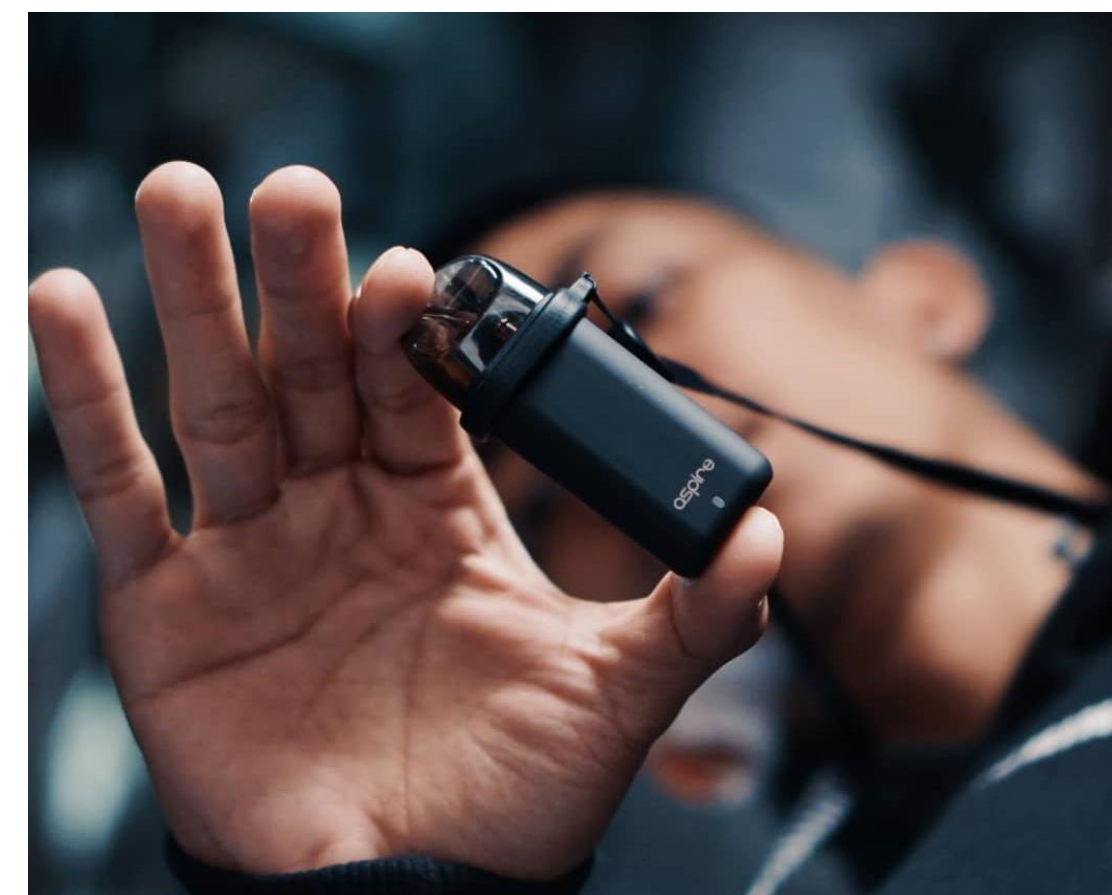
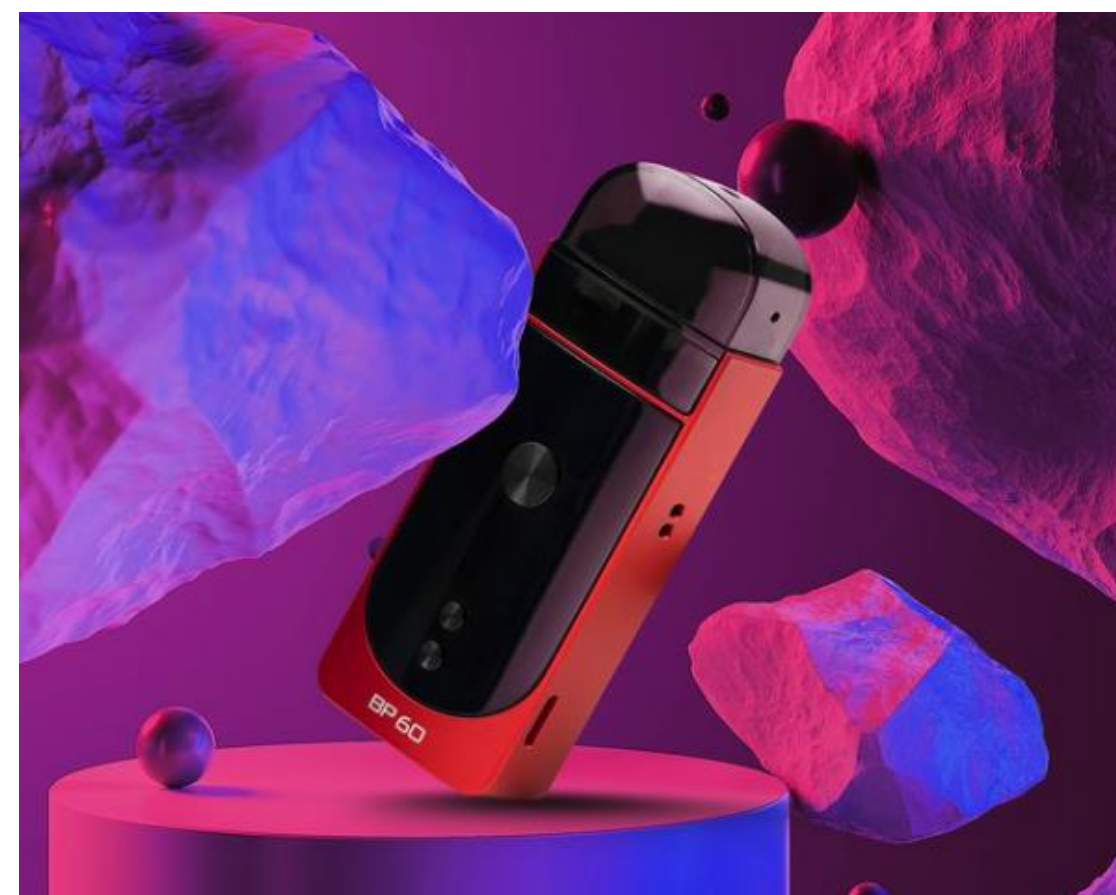

Disclaimer

This presentation (this "Presentation") has been prepared by Ispire Technology Inc. (the "Company") solely for informational purposes. The information included herein in this Presentation has not been independently verified. No representations, warranties or undertakings, express or implied, are made by the Company or any of its affiliates, advisers or representatives or the underwriters as to, and no reliance should be placed upon, the accuracy, fairness, completeness or correctness of the information or opinions presented or contained in this presentation. By viewing or accessing the information contained in this Presentation, you acknowledge and agree that none of the Company or any of its affiliates, advisers or representatives or the underwriters accept any responsibility whatsoever (in negligence or otherwise) for any loss howsoever arising from any information presented or contained in this Presentation or otherwise arising in connection with this Presentation. The information presented or contained in this Presentation is subject to change without notice and its accuracy is not guaranteed. None of the Company or any of its affiliates, advisers or representatives or the underwriters make any undertaking to update any such information subsequent to the date hereof except as required by law. This Presentation should not be construed as legal, tax, investment or other advice.

The Company filed a registration statement on Form S-1 with the U.S. Securities and Exchange Commission (the "SEC"), as well as other documents and any amendments or supplements thereto filed with the SEC, File No. 333—269470 (the "Registration Statement"), relating to its initial public offering of its securities in the United States, and the Registration Statement was declared effective by the SEC on April 3, 2023. The offering of the Company's securities made in the United States was made solely on the basis of the prospectus included in the Registration Statement. Any decision to purchase the Company's securities in any offering should be made solely on the basis of the information contained in the prospectus included in the Registration Statement.

This Presentation contains statements that reflect the Company's intent, beliefs or current expectations about the future. These statements can be recognized by the use of words such as " expects," " plans," "will," "estimates," "projects," "intends" or words of similar meaning, but the absence of these words does not mean that a statement is not forward-looking. These forward-looking statements are not guarantees of future performance and are based on estimates and information available to the Company, as of the date of this Presentation, and a number of assumptions about the Company's operations and certain risk factors, including those described in the "Risk Factors" section of the Company's annual report on Form 10-K for the fiscal year ended June 30, 2023 filed with the SEC on September 19, 2023. All statements other than statements of historical fact in this Presentation are forward-looking statements, including but not limited to, the Company's goals and growth strategies; the Company's expectations regarding demand for and market acceptance of the Company's brand and platforms; the Company's future business development, results of operations and financial condition; the Company's ability to establish manufacturing operations in Vietnam and the United States; the Company's ability to establish relationships with suppliers other than Shenzhen Yi Jia; the effect of regulations relating to the marketing and sale of vaping products in the United States and other countries; the Company's ability to maintain and improve the Company's infrastructure necessary to operate the Company's business; competition in the vaping industry; the expected growth of, and trends in, the markets for the Company's products and services in the markets in which jurisdictions that we sell the Company's products; the development of a market for cannabis vaping products outside of the United States, including the legalization of cannabis in certain European countries; the expected growth of, and trends in, the markets for the Company's products and services in the markets in which jurisdictions that we sell the Company's products; the effect of supply chain issues on the Company's ability to manufacture and the Company's ability and the ability of the Company's distributors to distribute product; the development of a market for cannabis vaping product and the Company's ability to market cannabis products to adult users; the Company's ability to compete successfully for both tobacco and cannabis products, the expected growth of, and trends in, the markets for the Company's products and services jurisdictions that we sell or plan to sell the Company's products; effects of the COVID-19 pandemic and steps taken by governments to address the pandemic and the effect of the COVID-19 pandemic on the Company's supply chain; government policies and regulations relating to the Company's operations, including regulations relating to the sale and distribution of the Company's vaping products and those relating to manufacturing operations; the Company's ability to develop and maintain effective disclosure controls and internal controls over financial reporting; the Company's ability to use of proceeds from its initial public offering in the manner contemplated by the Company; the effect of any sales or the anticipation of sales by the selling stockholders upon the market price of the Company's common stock; the Company's ability to meet the continued listing requirement on the Nasdaq Stock Market; general economic and business condition in China and elsewhere; the Company's ability to operate as a public company; the period of time for which its current liquidity will enable the Company to fund its operations; general economic and business conditions; the volatility of the Company's operating results and financial condition and the price of its common stock; the Company's ability to attract and retain qualified senior management personnel and research and development staff; and assumptions underlying or related to any of the foregoing and other risks detailed in the Company's filings with the SEC, including the Registration Statement, and available on the SEC's website at <http://www.sec.gov>.

Disclaimer (Continued)

These forward-looking statements involve known and unknown risks and uncertainties and are based on current expectations, assumptions, estimates and projections about the Company and the industry. The Company undertakes no obligation to update forward-looking statements to reflect subsequent occurring events or circumstances, or to changes in its expectations, except as may be required by law. Although the Company believes that the expectations expressed in these forward-looking statements are reasonable, it cannot assure you that its expectations will turn out to be correct, and investors are cautioned that actual results may differ materially from the anticipated results.

This Presentation does not constitute an offer to sell or an invitation to purchase or subscribe for any securities of the Company for sale in the United States or anywhere else. No part of this Presentation shall form the basis of or be relied upon in connection with any contract or commitment whatsoever. Specifically, these materials do not constitute a “prospectus” within the meaning of the US Securities Act of 1933, as amended, and the regulations enacted thereunder. This Presentation does not contain all relevant information relating to the Company or its securities, particularly with respect to the risks and special considerations involved with an investment in the securities of the Company and is qualified in its entirety by reference to the detailed information in the prospectus relating to its offering. Any decision to purchase the Company’s securities in any offering should be made solely on the basis of the information contained in the prospectus relating to its offering.

Neither the SEC nor any state securities commission has approved or disapproved of these securities or passed upon the accuracy or adequacy of this presentation. Any representation to the contrary is a criminal offense.

Investment Highlights

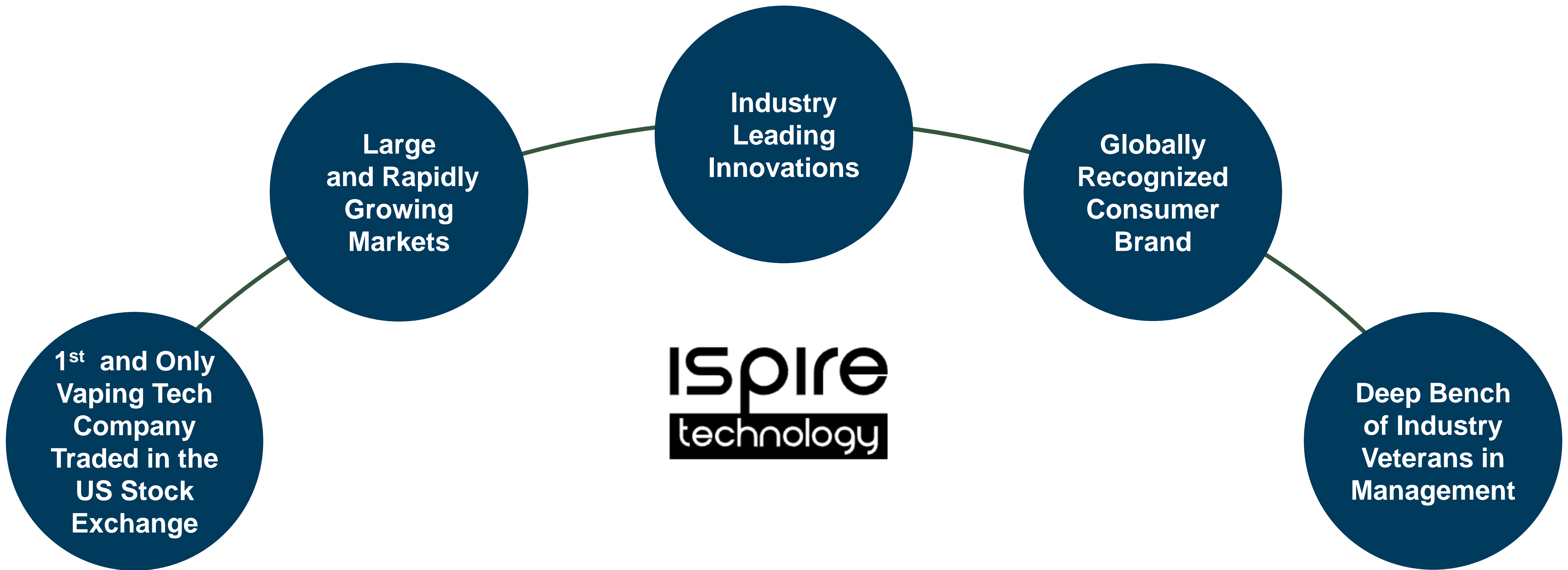

Company Overview

Ispire is a US company engaged in the research and development, design, commercialization, sales, marketing and distribution of our branded vaping products

Cannabis Products

Marketed under “**Ispire**” brand name, primarily on an ODM basis, cannabis vaping hardware sales currently are only in the US

Tobacco Products

Marketed under “**Aspire**” brand name, sold primarily through distribution network worldwide (except for China, US and Russia)

Strong R&D Capabilities

- +15 Years of experience
- +200 Core patents

Extensive Distribution Network (Tobacco Products Only)

- +150 Distributors
- +30 Countries

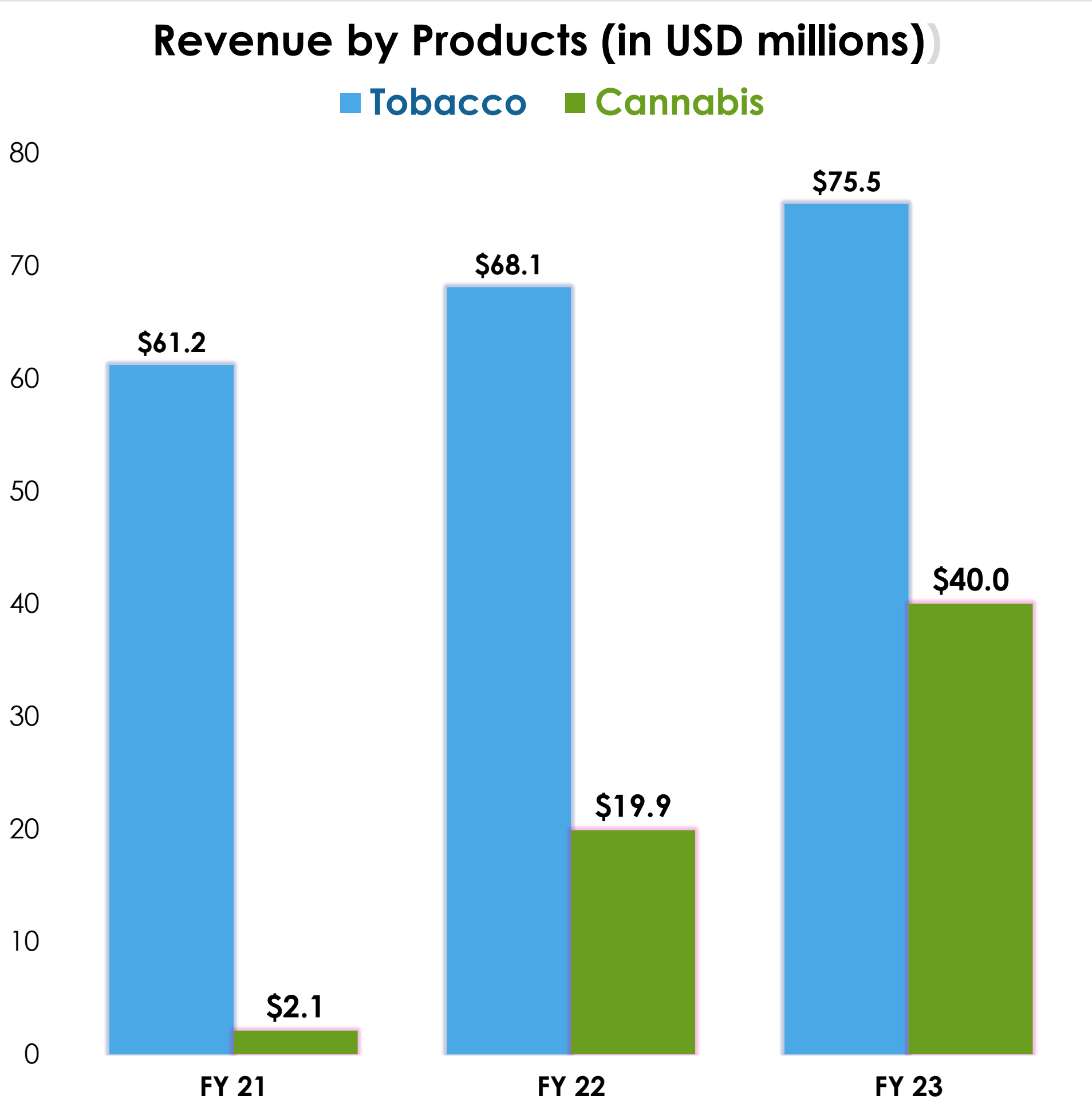

Corporate Structure ---- US-Based Corporation

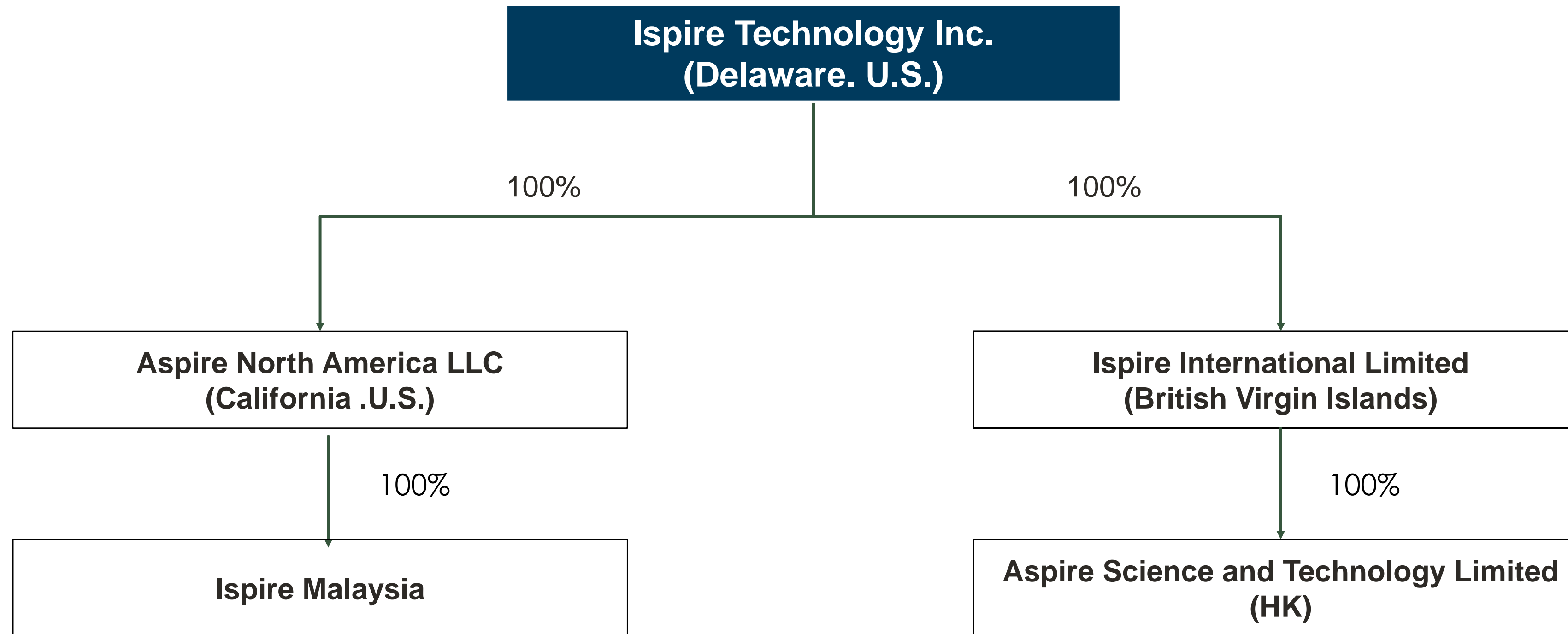

- Ispire Technology Inc. (the Company) is incorporated in Delaware on June 13, 2022.
- Aspire North America (product development, marketing and sales of cannabis vaping products)
- Aspire Science and Technology (product development, marketing and sales of tobacco vaping products)
- Ispire Malaysia (manufacturing and supply chain)

Our Technology : Disrupting the Cannabis Vaping Market

Proprietary Technology

Ducore™

Patented dual coil and airflow system technology enables users to create massive plumes of vape without burning the cannabis oil and eliminates the leakage of the oil from the unit, which we believe could provide the best-in-class airflow and taste

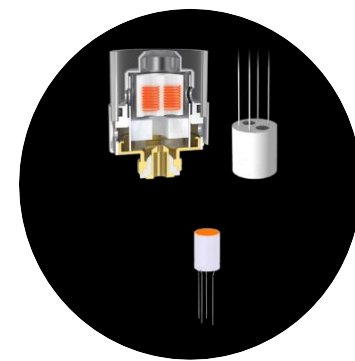

Dual Coils

Patented Ducore technology and a leak-proof anti-clog body to ensure hassle-free performance

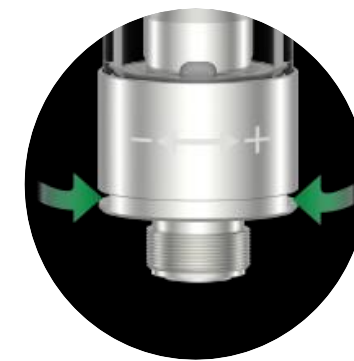

Adjustable Airflow Control

A fully customizable airflow system that allows you to easily adjust for the perfect hit every time



Stainless Steel & Pyrex Glass

Food-grade stainless steel center-tube is highly resistant to rust as well as heat, enhancing safety and durability



Huge Airflow Delivery

Airflow system that provides exceptional airflow that we believe is unrivaled by comparable products

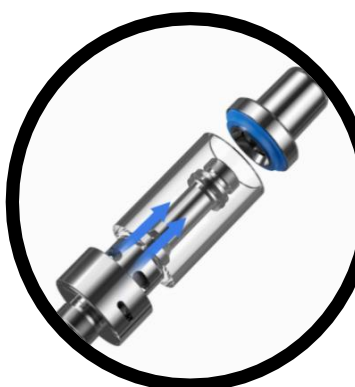

Leak-proof Design

Multi-channel airflow design that prevents oil leakage by capturing oil in the inner chambers

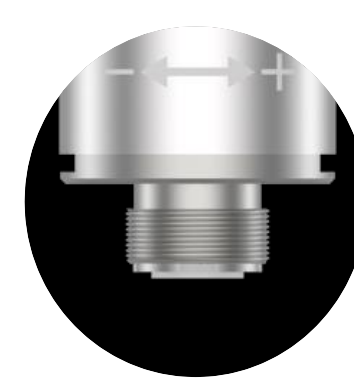

Connection Thread

The connector makes Ducore cartridge compatible with most batteries on the market

History of Industry Driving Innovation⁽¹⁾

Ispire will own or license a total of 200+ core technology patents issued across China, U.S. and Europe.



Technologies Leading the Marketplace

BDC (bottom dual coil) coil technology

- Enhances the flavor performance of e-liquid; Extends the tank e-liquid capacity; Improves the speed of wicking to increase coil life

BVC (bottom vertical coil) coil technology

- Enables the coil to last longer while still giving users the purest and cleanest taste from e-liquids

New coil technology with Cleito tank⁽¹⁾

- Frees up more restriction in the airflow, expands flavor profile and increases vapor production

(1)The technology was developed by a related party, which was 95% owned by our Co-Chief Executive Officer and which is our present supplier. Pursuant to agreements, the technology related to cannabis vaping products was transferred to our wholly-owned subsidiary, and the technology relating to tobacco products is licensed to a wholly-owned indirect subsidiary.

Sales and Distribution

Cannabis Products

- ✓ Sold directly by Ispire sales team in California, primarily on an ODM basis
- ✓ All sales to date have been in the United States, commenced marketing efforts in Canada and Europe, primarily in the European Union

Tobacco Products

- ✓ Network of more than 150 distributors, covering over 30 countries
- ✓ Distributors sell our products to wholesalers or directly to retail outlets and operate online channels such as Amazon



100%

FY23 sales of cannabis products within the United States



77.8%

FY23 sales of tobacco products within Europe



95.5%

FY23 sales of tobacco products from self-branded products



32.4%

FY23 sales of tobacco products from largest distributor

Overall Sales Ratio By Region

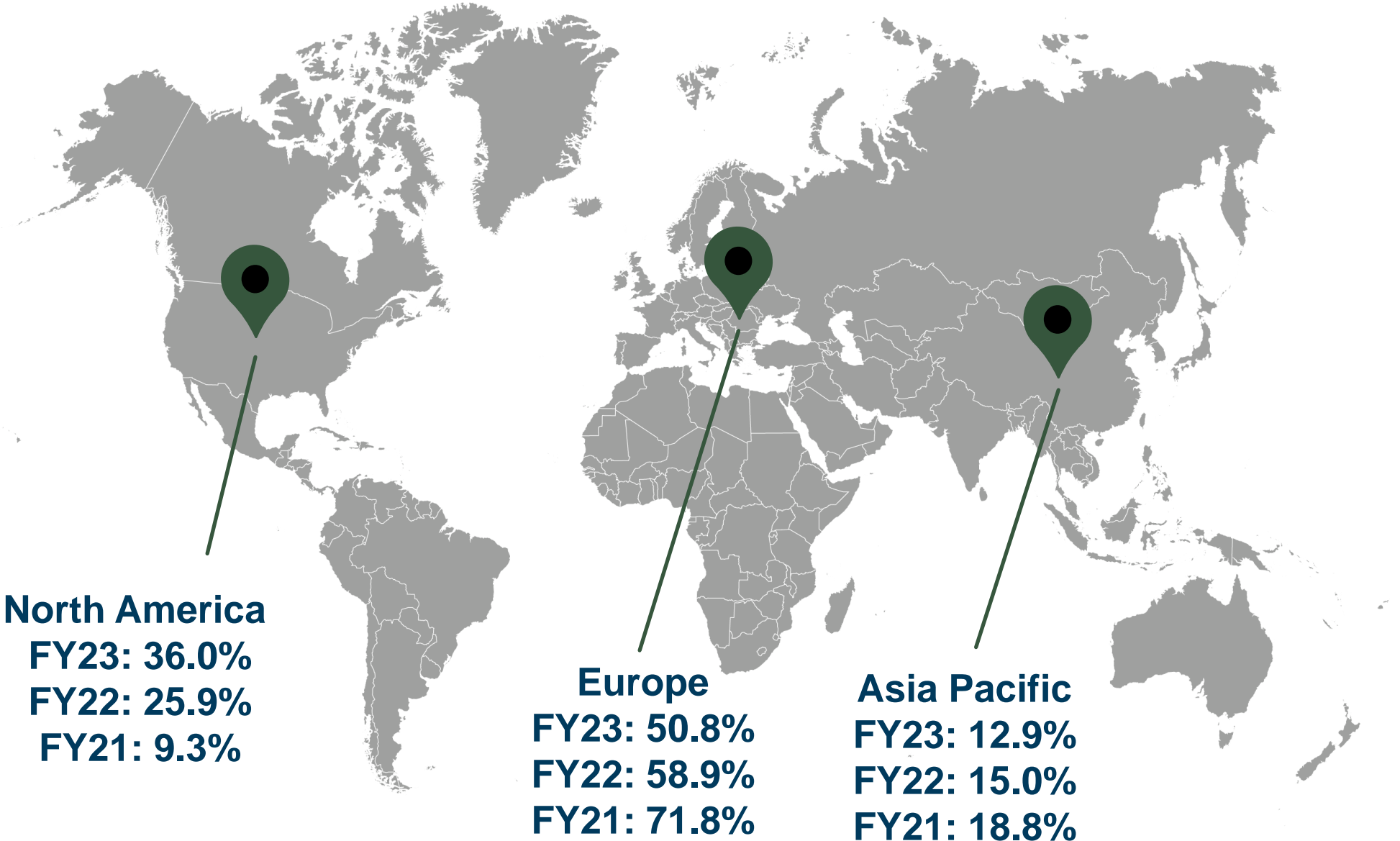

Regulatory Environment Provides Tailwinds for Growth

THE WALL STREET JOURNAL.

FINANCE | INVESTING

Health Care Roundup: Market Talk

Sept. 15, 2023 6:52 am ET



PHOTO: TOM WILLIAMS/CO-ROLL CALL/GETTY IMAGES

The **Department of Health and Human Services** has recommended the Drug Enforcement Agency to **move cannabis to Schedule 3 from Schedule I.**

Analysts expect the DEA to heed the recommendation in a few months.

...**The current tax treatment had a cash impact between \$40 million and \$140 million for some companies in the industry last year**, according to Alliance Global Partners' Aaron Grey. He estimates the DEA may move fast enough that some firms might see a cash-flow benefit by next year.

Europe



German cabinet OKs landmark bill over legal cannabis use

BERLIN, Aug 16 (Reuters) - Germany's cabinet passed a contentious bill on Wednesday to legalize recreational marijuana use and cultivation, one of the most liberal cannabis laws in Europe that could potentially provide further momentum for a similar worldwide trend.

The legislation, which still has to pass parliament, would allow adults to possess up to 25 grams (0.88 oz) of the drug, grow a maximum of three plants, or acquire weed as associates of non-profit cannabis clubs.



The Minnesota legislature legalized the possession and use of cannabis for persons 21 years of age or older effective August 1, 2023. The state is developing the regulatory framework for commercial cannabis activity, expected to roll out in 2024-25.

Cannabis Legalization in the U.S.

Though cannabis is still a Schedule I drug under federal law, 22 states and District of Columbia (D.C.) have approved marijuana for recreational purposes, and 42 states and US territories for medicinal use

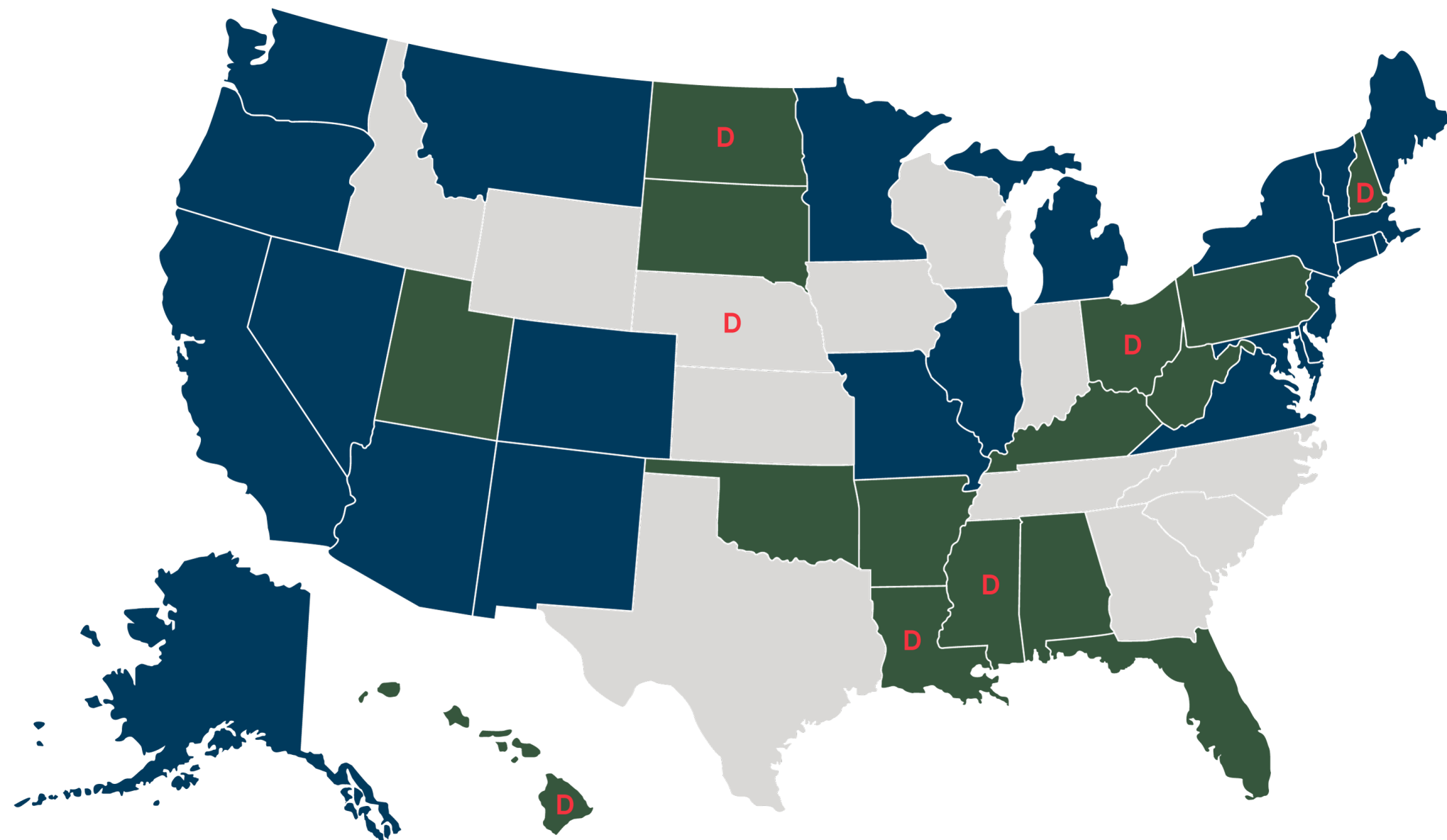

Notes: • Reflects law of states and territories, including laws which have not yet gone into effect. Does not reflect federal, tribal, or local laws.

Source: Wikipedia

Recent timeline of marijuana legalization

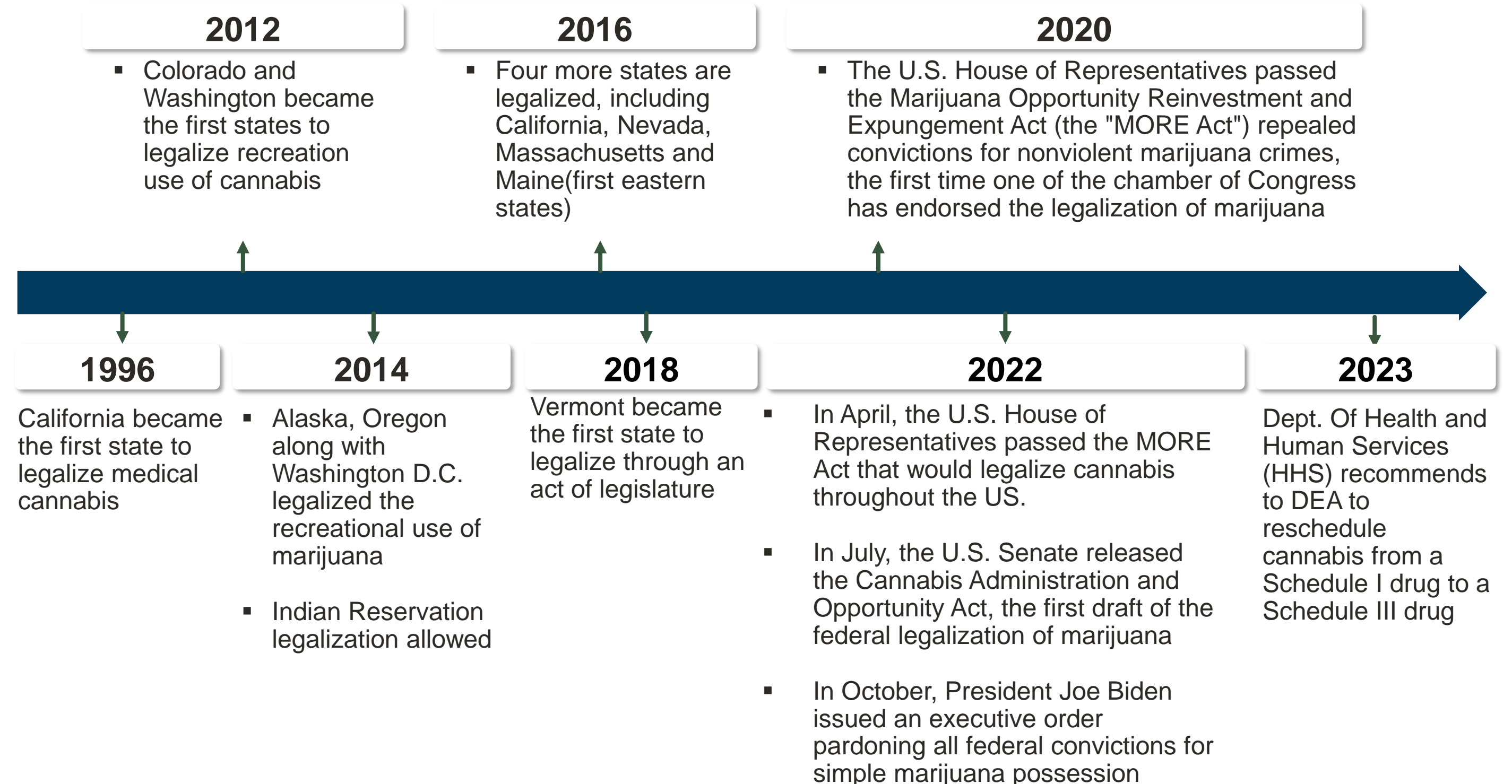

Growth Potential for Cannabis Markets

**Projected US Cannabis Market
2015 – 2025E (Retail Value)⁽¹⁾**

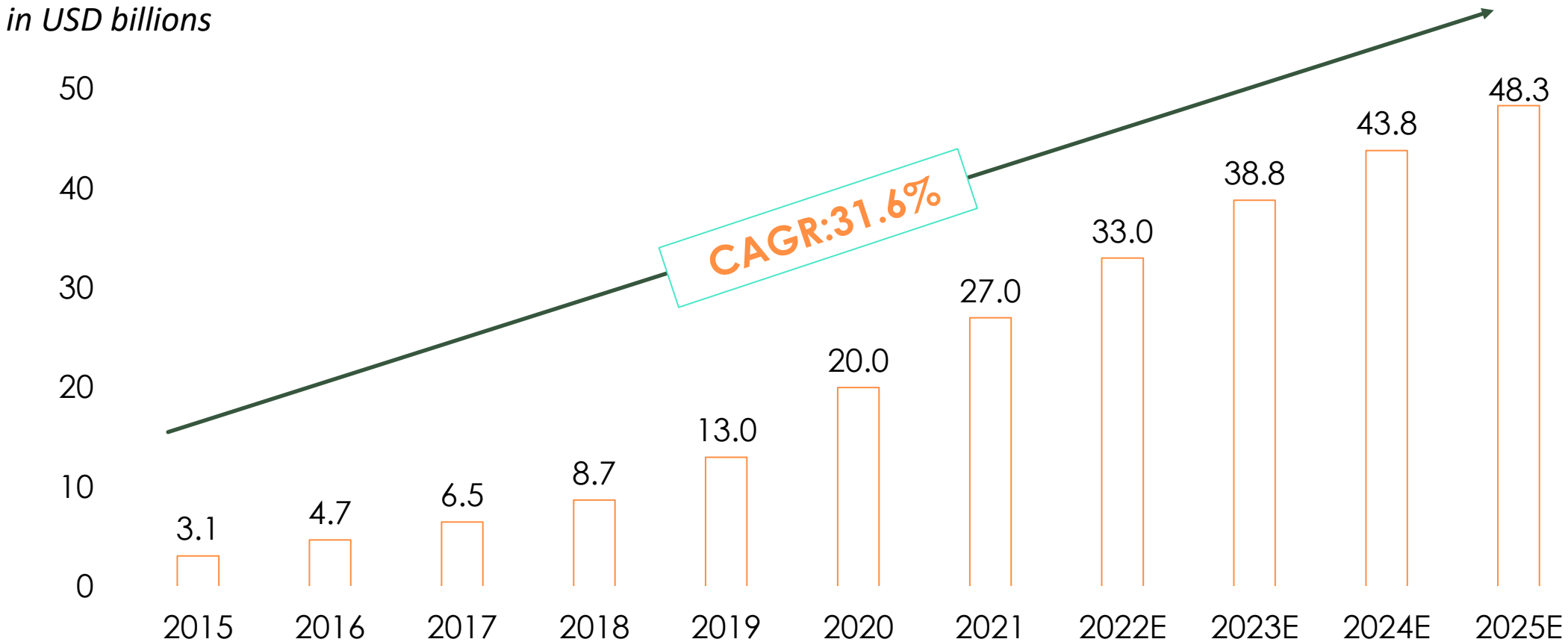

**Market Size of Cannabis Vapor Products
2020 – 2025E (Retail Value)⁽¹⁾**

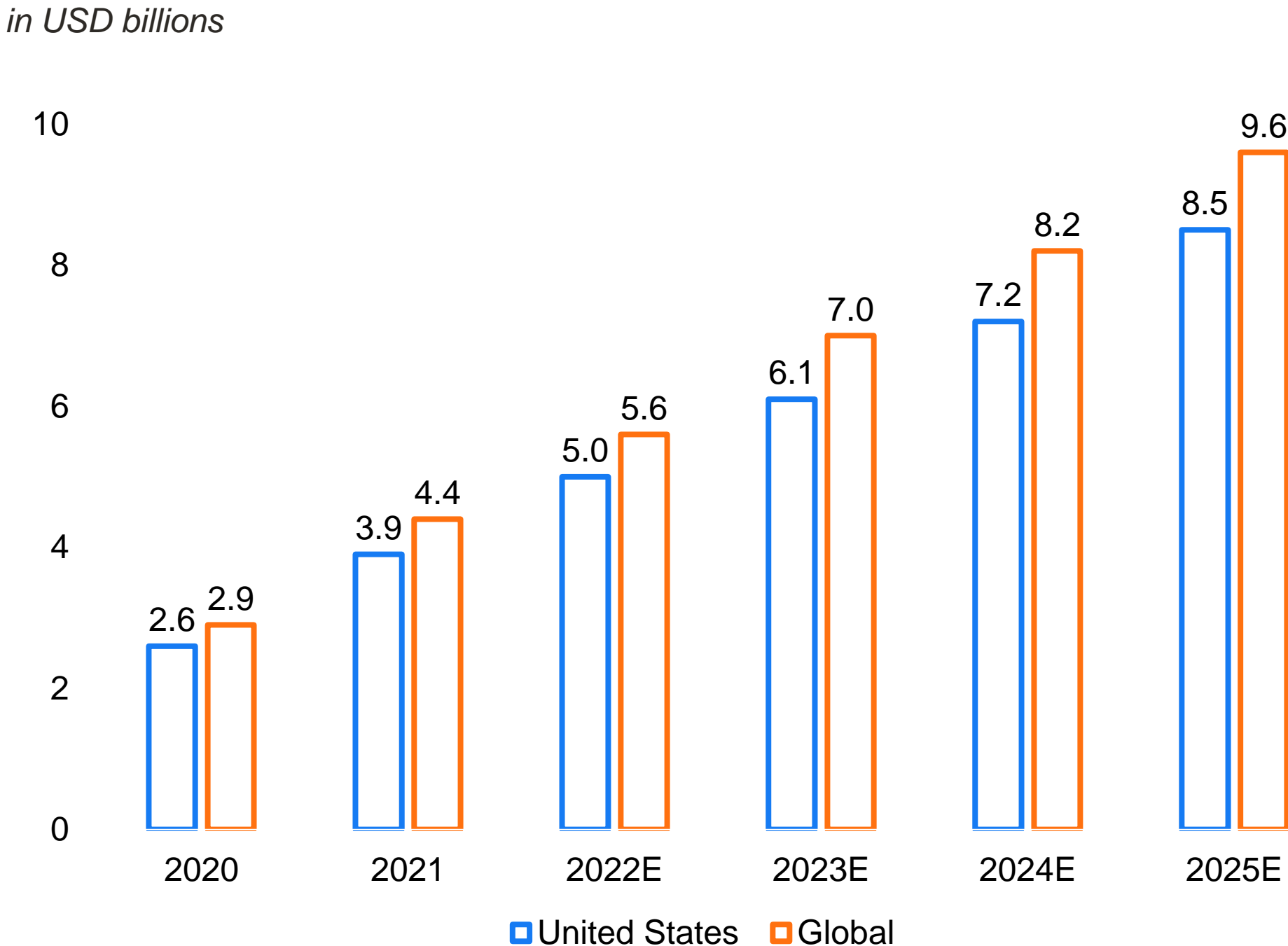

⁽¹⁾Source: The MJBiz Factbook/Euro Monitor

Ispire Cannabis Vaping Hardware ---- Current US Market TAM

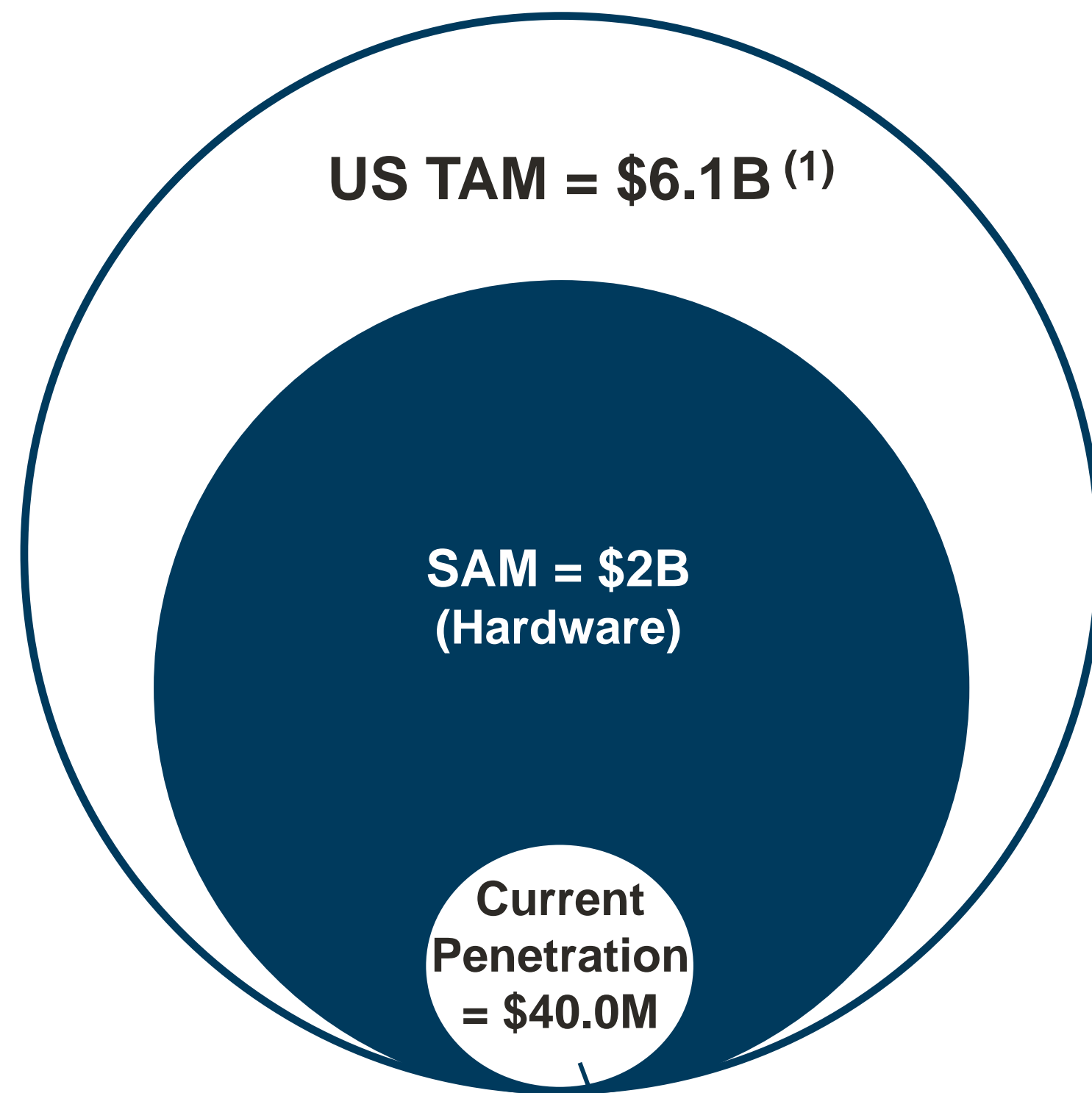

Ispire 2023 Revenue is approximately 2% of Serviceable Addressable Market

- Cannabis/CBD vaping total addressable market is projected at \$9.6 billion in 2025 ⁽¹⁾ with expected penetration from \$250M-\$280M, approximately 8-9% of SAM
- Cannabis vaping – Fastest growing segment in the fast-growing cannabis industry
- Favorable political environment anticipated based on the rise of popularity of cannabis

(1)Source: The MJBiz Factbook/Euro Monitor

Globally Recognized Tobacco Vaping Brand

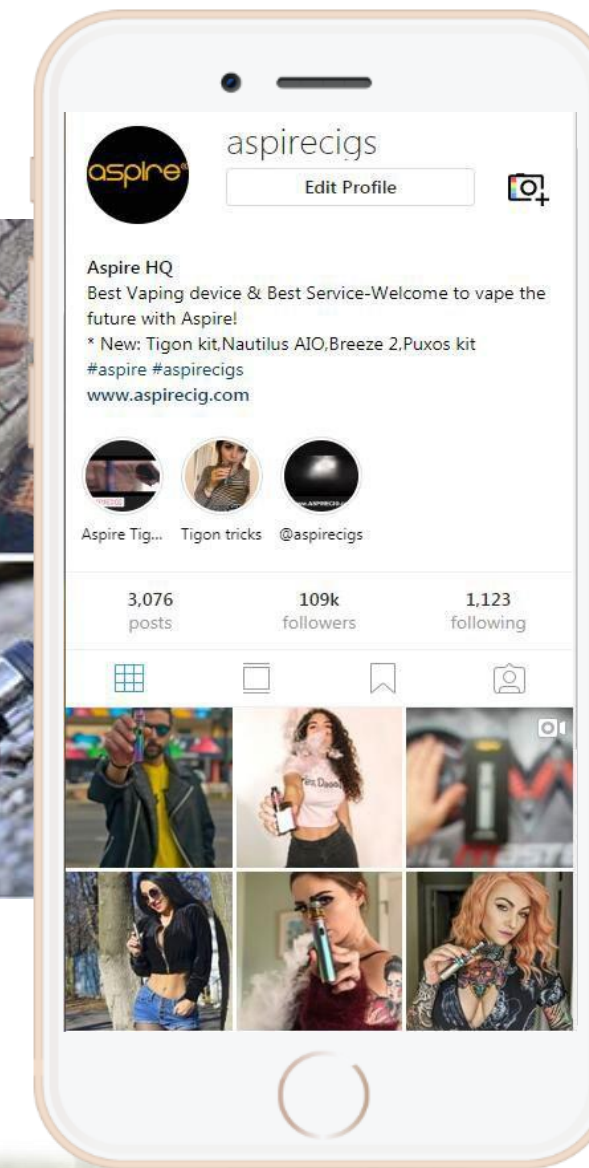

We are a well-known brand in Europe & US

- ✓ Tobacco products are marketed and sold in over 30 countries
- ✓ Our social media strategies aim to increase brand awareness; synergy across all platforms, including Instagram, Facebook and YouTube, following 21+ age verification guidelines
- ✓ Through social media, we promote and educate on current and new products, as well as to provide real-time support to customers



Bench of Industry Veterans

Tuanfang Liu | Co-Chief Executive Officer & Chairman



- Over 14 years of experience in research and development of the e-cigarette products and quality control management.
- Mr. Liu founded Shenzhen Yi Jia in 2010 and has served as its Chairman since then.
- Mr. Liu is responsible for daily operations and research and development of the e-cigarette and cannabis vaporizer technology products.
- Mr. Liu holds doctorate degrees in Business Management from Victoria University School of Management in Switzerland and EuroPort Business School in the Netherlands, respectively.

Daniel Machock | Chief Financial Officer



- Mr. Machock has been the Chief Financial Officer since August 2023. Dan brings 25 years of experience overseeing the financial strategy and performance at a number of fast-growing companies.
- Mr. Machock was most recently CFO at Appetize Technologies, a point-of-sale hardware and software company. He has previously led successful teams at several other technology companies in Los Angeles including as CFO at Chrome River and PostSMSCo.
- Mr. Machock received his bachelor's degree in accounting and finance from Indiana University and started his career in public accounting at Ernst and Young LLP in Chicago.

Michael Wang | Co-Chief Executive Officer



- 20+ years of experience as CEO, COO, and President. Approximately 12 years of internet technology and e-commerce experience.
- Mr. Wang served as the President, COO and Co-CEO of The Pharm/Sunday Goods (located in California and Arizona), a vertically integrated leader in the cannabis cultivation, processing, manufacturing, distribution, wholesale, and retail industry between 2018 to 2020.
- Mr. Wang received Bachelor of Science and Master of Science degrees in Aerospace Engineering in 1983 and 1985 respectively and received an MBA in Finance and General Management from the University of Chicago's Booth School of Business in 1992.

Tirdad Rouhani | Chief Operating Officer

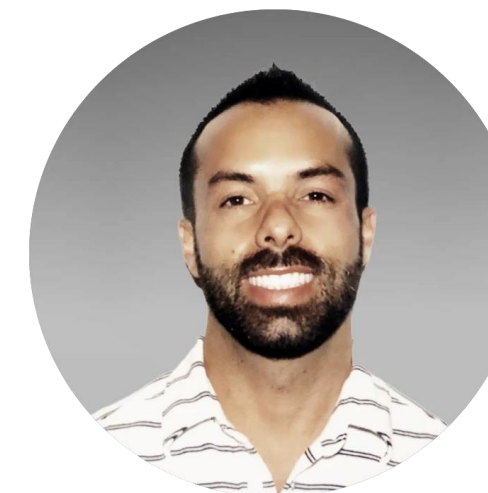

- Mr. Rouhani has been the Chief Operating Officer since July 2022 and held the role of Chief Operating Officer at Touchstone before taking on the role of Chief Executive Officer for Napalm Brands in March 2020.
- Mr. Rouhani co-founded two tech companies before converging on the cannabis industry.
- Mr. Rouhani received his undergraduate and graduate degrees from the University of Arizona.

Financial Performance (in USD mm)

	FY21	FY22	FY23
Tobacco Revenue	61.3	68.1	75.6
Cannabis Revenue	2.1	19.9	40.0
Total Revenue	63.4	88.0	115.6
Gross Profit	10.4	13.3	21.0
Gross Margin %	16.4%	15.1%	18.2%
Cash	85.2	74.4	40.3

Financial Overview (All figures in Millions)

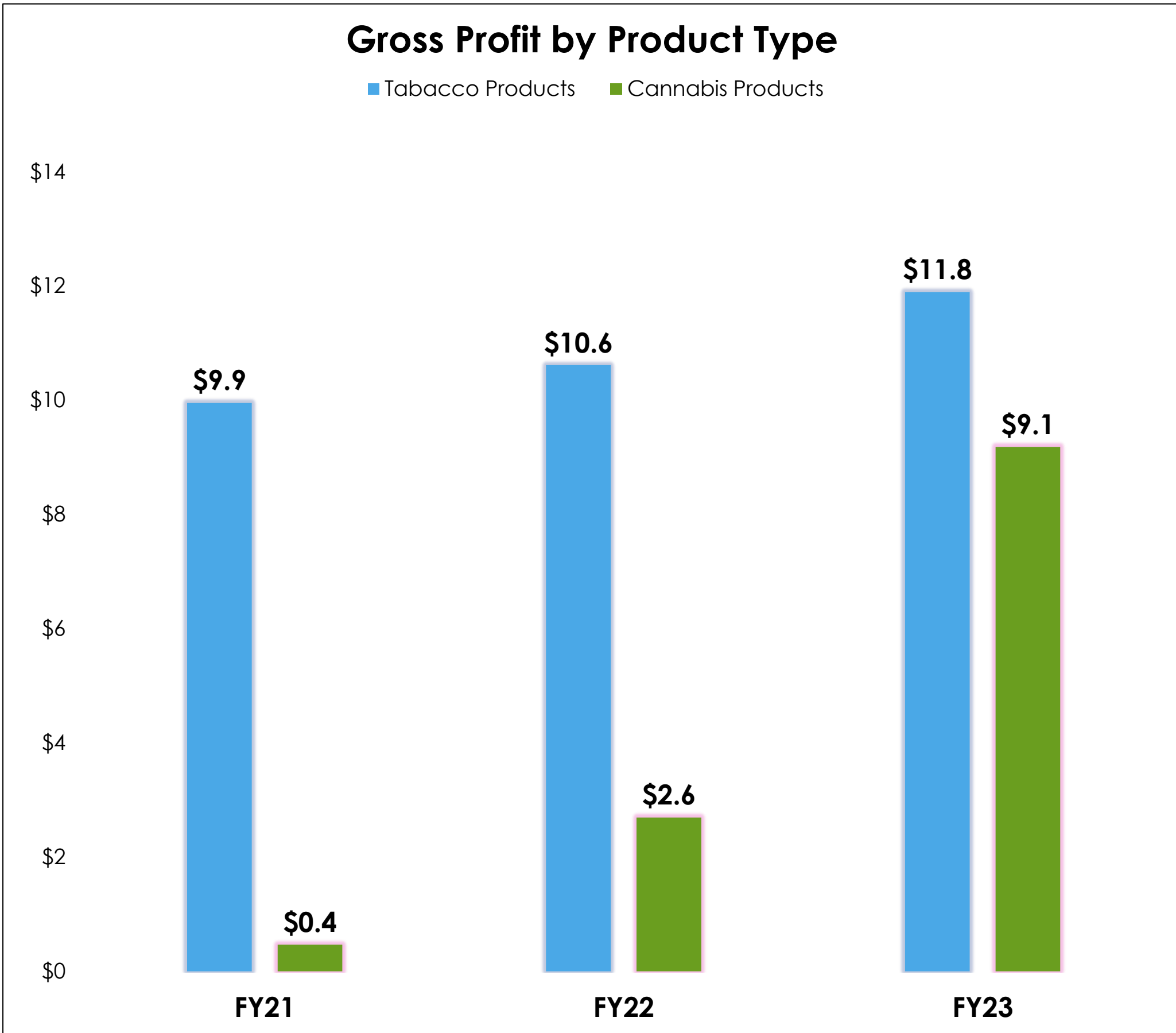
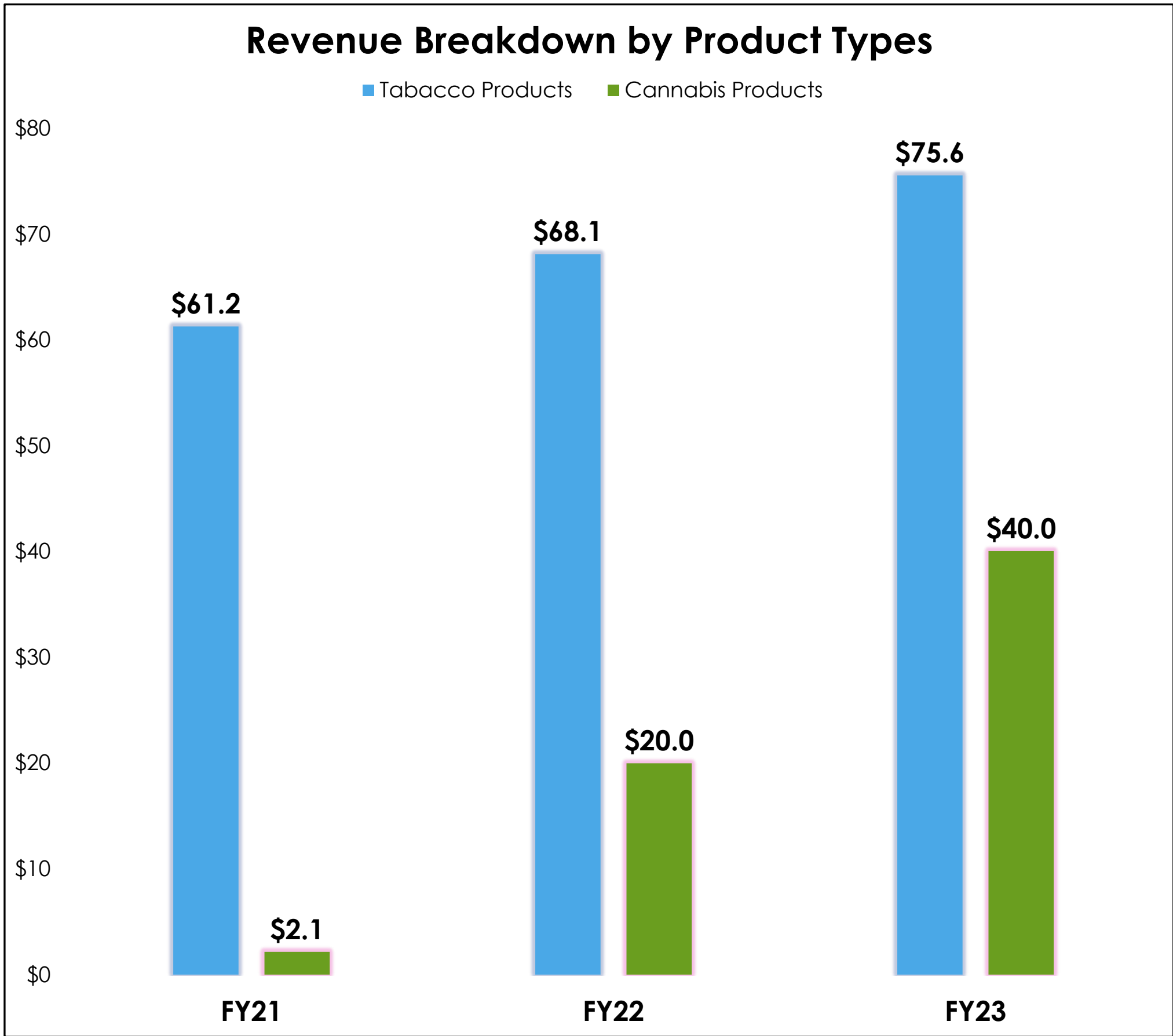

Investor Relations & Media Contact

Daniel Machock
Chief Financial Officer
Ispire Technologies Inc.
ir@getispire.com



Appendix

Highlights

1st Vaping Company Listed in the US

- The first vaping technology company listed in the U.S. stock market
- Driven by R&D leadership and history, **Ispire** provides innovative solutions to solve consumer pain points

Large and Rapidly Growing Markets

- Cannabis/CBD vaping total addressable market is projected at **\$9.6 billion in 2025⁽¹⁾**
- Cannabis vaping – Fastest growing segment in the fast growing cannabis industry
- Favorable political environment anticipated based on the rise of popularity of cannabis

Industry Leading Innovations

- As the pioneer of the vaporizer industry, Ispire's management has a history of ground-breaking vaping technologies
- We own, will own or license a total of **200+ core technology patents** issued across China, U.S., E.U. and etc.
- Capitalizing on proven success in products developments to **expand our OEM/ODM business in tobacco**

Globally Recognized Consumer Brand

- A well-known tobacco e-vaping brand in US and Europe, our brand Aspire e-vapor is sold in more than **30 countries**

Deep Bench of Industry Veterans

- Senior management team has a combined experience of **over 50 years** in consumer products with track record of innovation and execution in the vaping industry

(1)Market study for Ispire by Euromonitor International Limited dated January 12,2022

Cannabis and Tobacco Outlook

Ispire is providing the following outlook for the cannabis and tobacco vaping products for the fiscal year of 2024, which ends on June 30, 2024.

- Revenue from cannabis and tobacco vaping products was **\$40.0 million** and **\$75.6 Million** respectively for the fiscal year 2023
- Revenue for cannabis vaping products for the fiscal year 2024 is projected at somewhere between **\$80 million** and **\$90 million**, representing **growth between 100% and 125% from fiscal year of 2023**.
- Revenue for tobacco vaping products for the fiscal year of 2024 is projected at somewhere between **\$95 million** and **\$105 million**, representing **growth between 25% and 40% from the fiscal year 2023**.

Non-GAAP Fourth Quarter Net Income/Loss

(1)

	FY2023	FY2022
Net (LOSS)/INCOME for Q1-Q3	(4,512,513)	288,124
NET LOSS for Q4	(1,586,090)	(2,162,277)
+ Income Tax	175,304	-
+ IPO related expenses that's not used to offset proceeds	47,216	226,205
+ Allowance for doubtful accounts	1,103,058	-
+ HK patent legal expense	498,446	-
+ US patent legal fee	238,152	-
Non-GAAP NET INCOME/LOSS - Q4	476,086	(1,936,072)

(1) The Company believes that the non-GAAP financial information is important to an understanding of the Company business because the add-backs include one-time legal expenses that related to the Company's acquisition of intellectual property rights from a control party, expenses relating to the Company's initial public offering that were expensed and not treated as a cost of the offering, taxes and the allowance for doubtful accounts. Because Ispire does not have sufficient experience to establish a policy for establishing a reserve for doubtful accounts, at June 30, 2023 it established a reserve based on the age of the outstanding receivables. Although the Company believes that a significant percentage of these accounts receivable will be collected, and that this allowance is non-recurring; it is possible that a significant percentage of the reserved accounts will be not collected. Accordingly, non-GAAP information relating to the allowance for doubtful account should be viewed with the understanding it may become a recurring expense, and thus part of the Company's normal operations.