

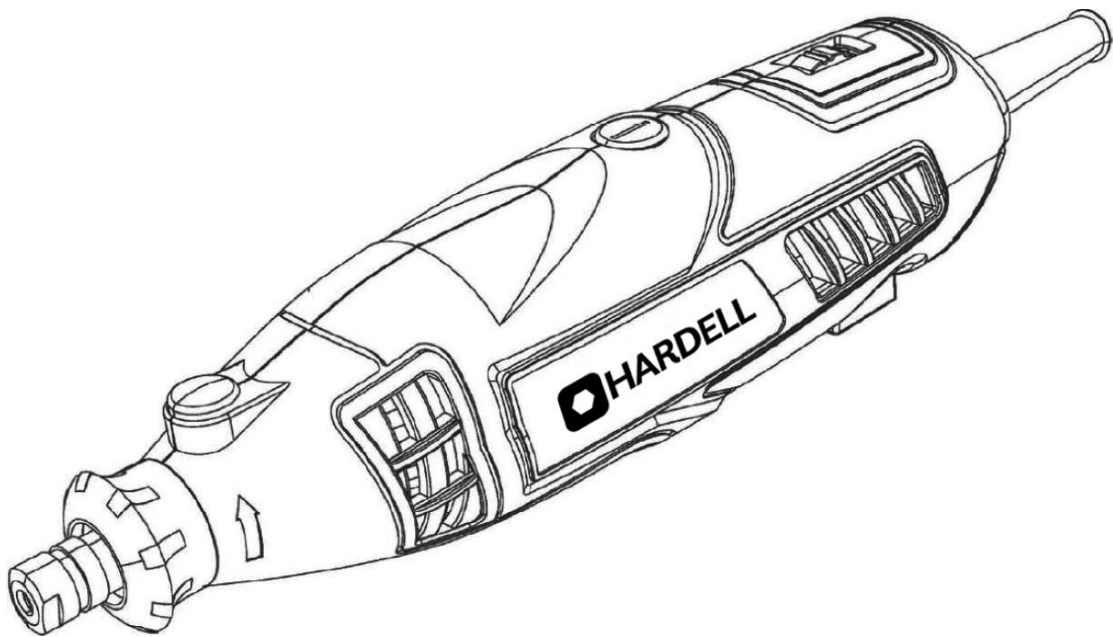

## Variable Speed Rotary Tool Kits Instruction Manual



Thank you for purchasing this product. To ensure proper use and trouble-free operation, please read this guide carefully before operating. If there is any issue, please contact us via Amazon or email: [hardell.service@gmail.com](mailto:hardell.service@gmail.com), we will help you within 12 hours.

## TECHNICAL SPECIFICATIONS

Available Voltages	110V/220V~
Maximum Output	160W 50/60Hz
No Load Speed	8,000-35,000rpm
Collet Chuck Capacity	Max 1/8" dia.

## KNOW YOUR ROTARY TOOL

Before attempting to use any tool, familiarize yourself with all operating features and safety requirements.

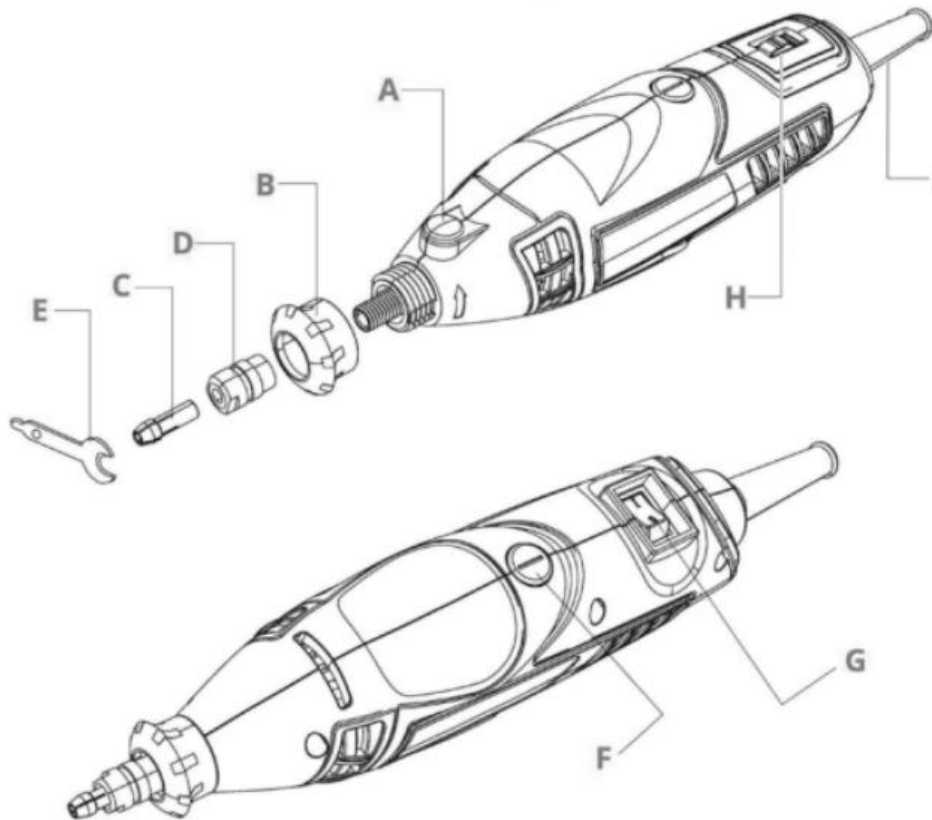

PART	DESCRIPTION	PART	DESCRIPTION
A	Shaft lock button	F	Brush cap
B	Housing cap	G	ON/OFF switch
C	Collet	H	Speed control dial
D	Collet nut	I	Power cord
E	Collet wrench		

## FUNCTION DESCRIPTION

### ON/OFF SWITCH

This product has an easy access power switch(G) located at the bottom of the tool. To turn the tool ON, push the ON/OFF(I/O) switch(G) to the ON(I) position.

To turn the tool OFF, push the ON/OFF(I/O) switch(G) to OFF(O) position.

Never start up or stop the tool when the accessory is in contact with the piece.

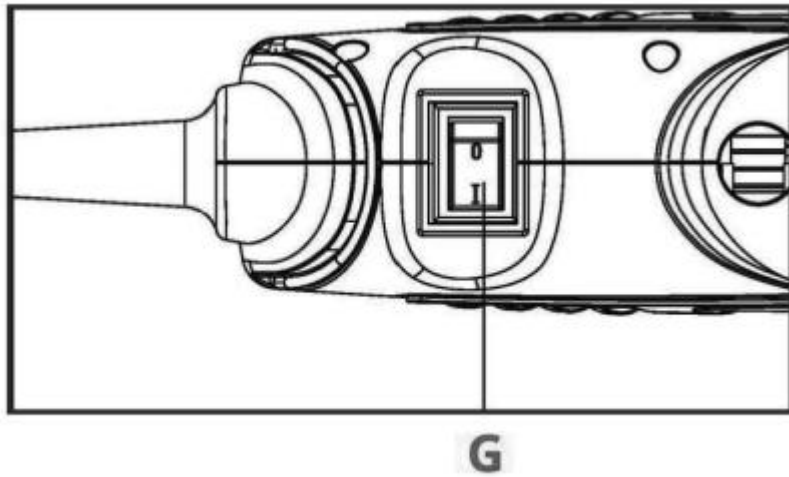

### INSTALLING ACCESSORIES

**WARNING!** Do not press the shaft lock button(A) while rotary tool is running.

1. Unplug the rotary tool.
2. Press and hold the shaft lock button(A), and rotate the shaft by hand until the shaft lock engages the shaft, preventing further rotation.
3. With the shaft lock button engaged, use the collet wrench(E) to loosen the collet nut(D), if necessary.
4. Insert the shank of the accessory into the collet as deep as possible. With the shaft lock(A) engaged, tighten the collet nut(D) with the provided wrench (E) until the accessory shank is gripped by the collet.
5. Avoid excess tightening of the collet nut(D).

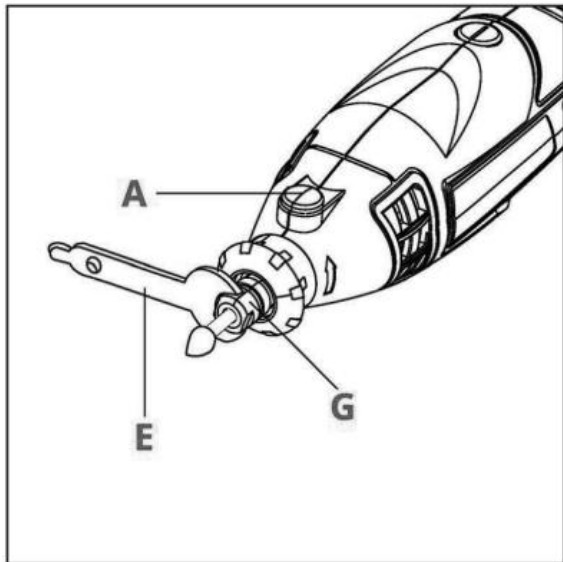

## REMOVING ACCESSORIES

1. Unplug the rotary tool.
2. With the shaft lock(A) engaged, loosen the collet nut(D) with the provided wrench(E).
3. Remove the accessory.

## TO INSTALL:

### IF USING THE DRUM MANDREL:

1.Align appropriate sized sanding drum over mandrel and push down to completely cover drum end of mandrel.

2.Insert the slot end of the provided wrench into the slot on top of the mandrel and tighten the screw on the drum mandrel head to expand the drum and securely hold the sanding drum in place.

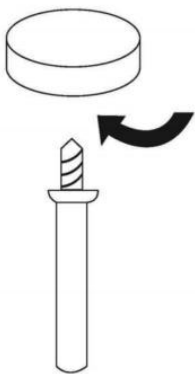
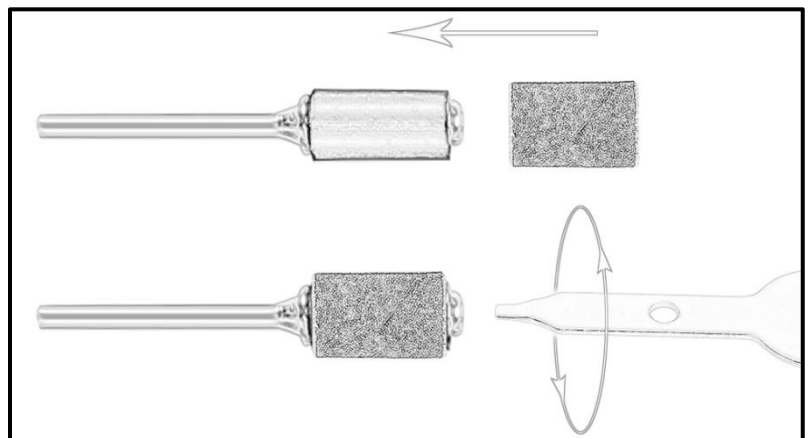

### IF USING THE SCREW MANDREL:

- 1.Align desired accessory hole with mandrel screw head.
- 2.Screw accessory onto mandrel by twisting clockwise until secure.



Whenever you hold the tool, be careful not to cover the air vents with your hand. This blocks the air flow and causes the motor to overheat.

## CUTTING GUIDE

The cutting guide comes completely assembled and ready to use on a variety of materials up to 20mm thick. Always hold the tool firmly, using a slow steady pressure to guide the tool through your work. The speed of the tool will do the work.

**IMPORTANT:** Always cut in clockwise direction except when following a template(outlet box), then cut in counter clockwise direction.

## INSTALLATION INSTRUCTION OF THE CUTTING GUIDE

STEP 1. Remove the housing cap (A) from the end of the tool and set housing cap aside. The original housing cap must be reinstalled when this attachment is not used (Fig.1).

STEP 2. Screw the Shield onto the tool using the lock nut B (Fig.2).

Tighten collet nut.

STEP 3. Position the Shield such that it will redirect debris, sparks, and dust away from the user using the positioning tabs C (Fig.3).

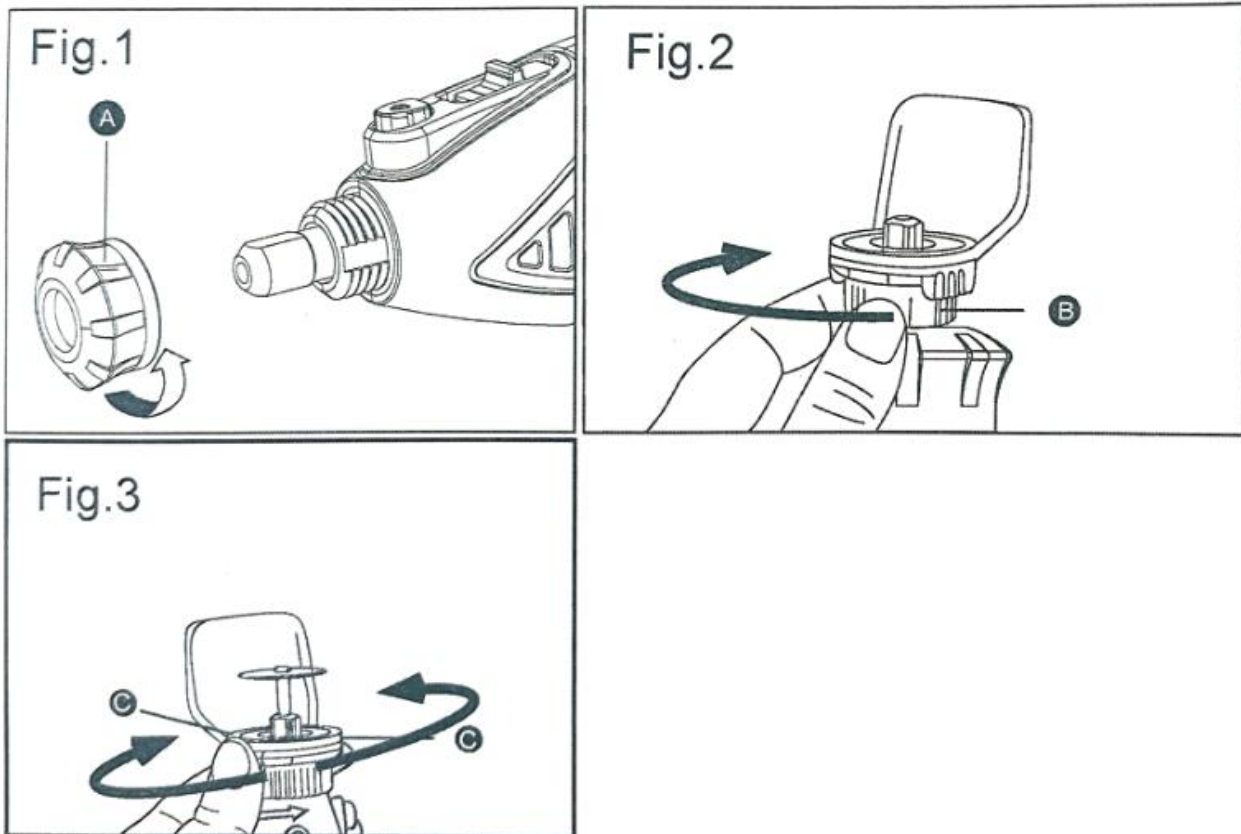

## INSTALLATION DIAGRAM OF FLEXIBLE DRIVER

It is extremely important to carefully read and follow the directions below.

Do not operate the flexible shaft with a sharp or multiple bends. Over bending the shaft can generate excessive heat on the cover or hand piece and may cause the Flexible Driver to disengage from the tool. The minimum recommended bend radius is 6".



1. Unscrew the plastic nut, hold the lock cap, and unscrew the chuck nut.

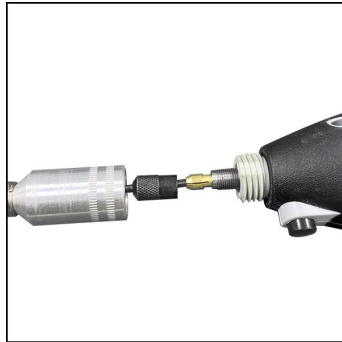

2. Pull out the shaft and insert the chuck.



3. Hold down the lock cap and use a spanner to tighten the collet nut.

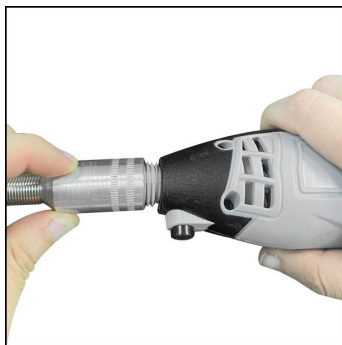

4. Tighten the shaft cap.

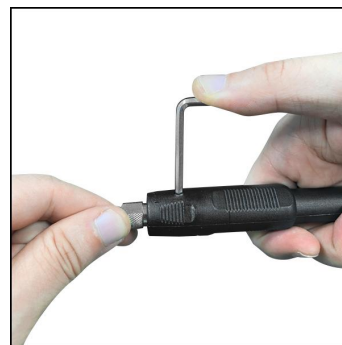

5. Insert the soft shaft hook into the small hole at the end of the flexible shaft and hold it to open the chuck nut.



6. Insert the accessories that need to be installed, hold down the hook, and use a small wrench to tighten the nut.









1. Hold down the lock cap and unscrew the chuck nut.

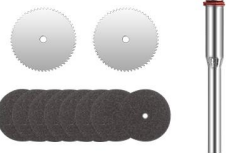

2. Insert the accessories that need to be installed and then hold down the lock cap and use a small wrench to tighten the nut.

## DIRECTIONS FOR USE

1. With small milling cutters /grinding pins: Use a high speed.
2. With large milling cutters/grinding pins: Use a low speed
3. Exert only moderate pressure on the work piece and allow it to be processed at uniform speed.
4. You will not finish your work sooner by exerting heavy pressure. On the contrary, heavy pressure will cause the drive unit to slow down or stop and will overload the motor.

<b>Drilling</b>		Drill Bits 2.4mm * 1 Drill Bits 3.2mm * 1	Diamond drill bits are perfect for drilling holes in hard materials such as glass, rock, and wood.
<b>Carving/Engraving</b>		Engraving Needle * 2	It is very easy to use for accurate DIY craft engraving on glass, wood, metal, plastic, mirrors, and other materials.
<b>Cutting</b>		Saw blades * 2 Resin Cutting Disc * 25 Red piece Holder * 1	Suitable for cutting only light and small projects. Easy to cut plastics, wood, housings, and aluminum brass, etc.
<b>Polishing</b>		Wool felt wheels * 4 Slef-tapping Holder * 1 Stainless Steel Brush * 1 Sanding paper * 25	Suitable for polishing on hardwood, softwood, plastic, steel, aluminum, copper, shell, stone, ceramic, glass and other materials
<b>Sanding</b>		Large sanding bands * 5 Grinding Stones * 8 Large rubber column * 1	Suitable for polishing and grinding on plastic, steel plate, aluminum, copper, shell, stone, ceramics and other rough surfaces, removing rust from metal surfaces
<b>Others</b>		Collets * 2(2.4mm/3.2mm) Sharpening stone * 1 Small Wrench * 1 L-shaped wrench * 1 Flexible shaft * 1 Cover Shield * 1	Suitable for polishing and grinding on plastic, steel plate, aluminum, copper, shell, stone, ceramics and other rough surfaces, removing rust from metal surfaces

Speed setting for Rotary accessories please refer to the picture on the next page.

**FC CE RoHS**



Made in China

**Note:Each number settings listed in the speed charts=000RPM'S**

Speed setting for Rotary accessories										
Function	Accessory Description	Soft wood	Hard wood	Plastic	Steel	Aluminum, brass, ect.	Shell, stone	Ceramic	Glass	
Polished Debur	Grinding wheel	/	/	25-32	25-32	25-32	25-32	25-32	/	
	Diamond Grinding Needle	15-32	15-32	15-32	15-32	15-32	15-32	15-32	15-32	
	Sanding band	10-25	10-25	10-25	10-25	10-25	10-25	10-25	/	
Drilling	Drill bits	25-30	25-30	25-30	/	/	/	/	/	
Polishing	Wool felt wheel	12-25	12-25	12-25	12-25	12-25	12-25	12-25	12-25	
Engarving	Engarving cutters	15-32	15-32	15-32	/	/	/	/	/	
Cleaning	Stainless brush	10-20	10-20	10-20	10-20	10-20	10-20	10-20	10-20	
Cutting	Cut off wheel	/	/	25-35	25-35	25-35	25-35	/	/	
	Cut off wheels fiberglass	/	/	25-35	25-35	25-35	25-35	/	/	
	Diamond cutting disc	/	/	/	/	/	25-35	25-35	/	
	Spiral Cutting Bits	Spiral Cutting Bits	For best results, use at 30 RPM.							
Switch Setting		1	2	3	4	5	6	MAX		
Speed Range		7-15	15-18	18-23	23-27	27-30	30-33	33-35		