



### Product Name

Niche Unframed Cistern

### Product Line *(from which the product is customised)*

Niche

### Intended Use

### Product Identifier *(if applicable)*

n/a

### Product Description *(measurements, materials, usage)*

A 4.5/3 litre dual flush plastic cistern suitable for inwall applications. The cistern features a number of contemporary button design options with concealed fixing that are pneumatically operated for ease of operation and installation.

### Place of manufacture

China

### Legal and Trading name of the manufacturer(s)

Harrier Imports Ltd

### Legal and Trading name of the importer

Harrier Imports Ltd

### Address for service

**Street** 195 Whites Road  
**Suburb** Ohoka  
**City, Country** Christchurch, New Zealand  
**Postcode** 7692

### Website

<https://www.propelindustries.co.nz>

### Email

[orders@propelindustries.co.nz](mailto:orders@propelindustries.co.nz)

### Phone number

0800 427 335

### NZBN *(if applicable)*

9429045864780

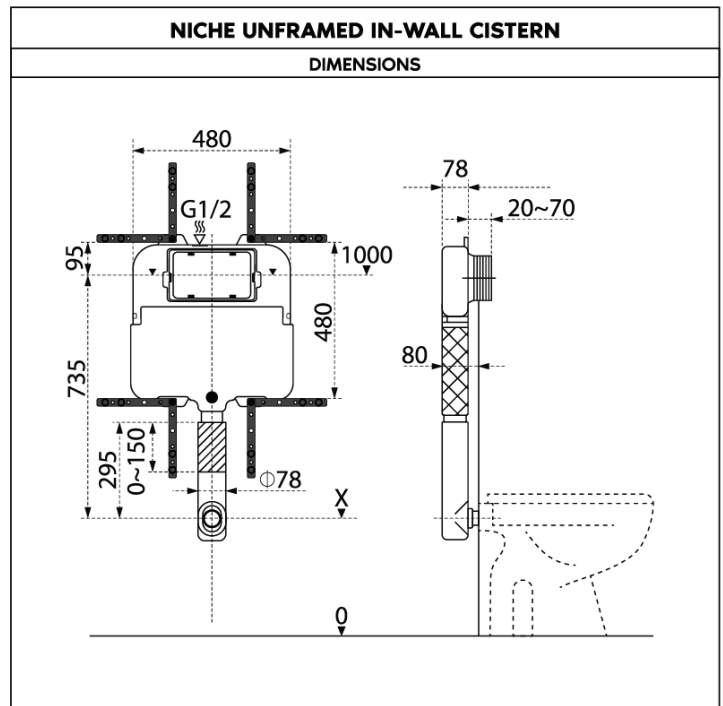

**IMPORTANT:** Dimensions provided are as accurate as possible at the time of publication and may vary within a reasonable tolerance range. Measurements are subject to change or cancellation as products are improved. No responsibility is assumed for use of superseded or voided dimensions. Be sure to measure product before installation and visit the Propel Industries website for the most up to date measurements  
Version Date: 22/06/2023

## Relevant Building Code clauses

F2.3.1

## Statement on how the building product is expected to contribute the compliance

**F2 Hazardous Building Materials** This product is constructed of materials that will not emit harmful concentrations of substances from exposed surfaces.

## Limitations on the use of the building product

n/a

## Design requirements that would support the use of the building product

## Installation and Maintenance requirements

Install guides are available on our website for download

[DOWNLOAD INSTALL GUIDE](#)

Is the building product/building product line subject to warning or ban under section 26?

Yes

No