

SELF-CONTAINED UNIT

INSTALLATION & OPERATION INSTRUCTIONS

*Read all instructions before you operate your Self-Contained Unit.
Save these instructions!*

www.theoutdoorplus.com



TO INSTALLER: Leave this manual with the Self-Contained Unit
TO CONSUMER: Keep this manual for future reference.



WARNING

Improper installation, adjustment, alteration, service, or maintenance can cause injury or property damage. Read the installation, operating, and maintenance instructions thoroughly before installing or servicing this equipment.



WARNING

Do not store or use gasoline or other flammable vapors and liquids in vicinity of this or any other appliance. An LP-cylinder not connected for use shall not be stored in the vicinity of this or any other appliance.

WARNING LABELS & SYMBOLS





THIS IS A SAFETY ALERT SYMBOL

When you see this symbol in on the fire feature or manual, look for one of the following signal word panels alerting you to the potential for personl injury, death or major properety damage.

 **DANGER**
FOR OUTDOOR USE ONLY

 **DANGER**
If you smell gas:
• Shut off gas to the appliance.
• Extinguish any open flame.
• If odor coutinues, keep away from appliance and immediately call supplier or fire department.

 **WARNING**
Do not store or use gasoline or other flammable vapors and liquids, in the vicinity of this or any other appliance.
An LP-Cylinder not connected for use shall not be stored in the vicinity of this or any other appliance.
For use with Natural or Propane gas only. NO SOLID FUELS TO BE USED WITH THIS SYSTEM.

 **WARNING**
If the information in this manual is not followed exactly, a fire or explosion may result causing property damage, personal injury, or loss of life.

 **DANGER!**



CARBON MONOXIDE HAZARD

This appliance can produce carbon monoxide which has no odor.

Using it in an enclosed space can kill you. Never use this appliance in an enclosed space such as a camper, tent, car, or home.

 **WARNING**
All fire pits must have a gas shut off on the outside of the exterior of the fire pit to allow for emergency shut off and maintenance.

 **WARNING**
Product is not intended to be a starter for wood or any other combustibles.

WARNING LABELS & SYMBOLS

 **WARNING**

Select a location where the fire pit can be attended during operation. Never leave an operating fire pit unattended.

 **WARNING**

Young children should be carefully supervised when they are in the area of the fire pit.

 **WARNING**

Flammable gas under pressure. Leaking LP-gas may cause a fire or explosion if ignited causing serious bodily injury or death. Contact a certified LP-gas supplier for repairs, or disposal of this cylinder or unused LP-gas.

 **WARNING**

Use only in compliance with applicable codes.

 **WARNING**

Never alter product or configuration in any way.

Installation must conform with local codes or, in the absence of local codes, with the National Fuel Gas Code, ANSI Z223.1 / NFPA 54, or International Fuel Gas Code. The appliance, when installed, must be electrically grounded in accordance with local codes or, in the absence of local codes, with the National Electric Code, ANSI/NFPA 70, if applicable.

WARNING LABELS & SYMBOLS

IMPORTANT SAFETY INFORMATION FOR INSTALLERS:

Leave this manual with the end-user and instruct them to retain it for future reference. Instructions and product updates are also available at www.theoutdoorplus.com under the Manuals/Documents tab.

IMPORTANT SAFETY INFORMATION FOR END USERS:

Never leave an operating fire pit unattended or with someone not familiar with its operation or emergency shut-off locations. Both children and adults should be alerted to the hazards of high surface temperatures and should stay away to avoid burns and clothing ignition. Young children should be carefully supervised when they are in the area of fire pit.

Keep the appliance area clear and free from combustible materials, gasoline, and other flammable vapors and liquids.

- The Outdoor Plus Company, Inc./TOPFIRES recommends that our products are installed by professionals locally licensed by the authority having jurisdiction in gas piping. All installation instructions must be followed to ensure proper performance and safety. The Outdoor Plus Company, Inc./TOPFIRES assumes no responsibility for problems relating to the installation.

- To qualify for warranty, all instructions must be strictly followed. Otherwise, warranty may be void. Never alter product or configuration in any way.

- Annual servicing should be handled by professionals certified in the US by the National Fireplace Institute (NFI) as NFI Gas Specialists or in Canada by WETT (Wood Energy Technical Training).

- It is the installer's responsibility to ensure a safe installation and to educate the end-user regarding the features, safety recommendations and proper operation of this product.

- Installers must carefully follow the instructions in this manual to prevent personal injury or property loss. These instructions contain information critical to the safe installation and operation of the fire pit.

- Instructions are updated as needed. It is the responsibility of the installers to check for product updates and installation manual updates at www.theoutdoorplus.com/documents/ prior to installation.

- It is the responsibility of the installer to follow:

- The National Fuel Gas Code, ANSI Z223.1/NFPA 54 or International Fuel Gas Code.

- Natural Gas and Propane Installation Code CSA B149.1 or CSA B149.2.

- The National Electrical Code, ANSI/NFPA 70. In Canada, Canadian Electrical Code CSA 22.1.

- Local codes

- Only use gas/fuel type specified for this fire pit as noted on the fire pit control box label. NEVER use an alternative fuel to include bio-fuel, ethanol, lighter fluid or any other fuel.

- Gas pressure and type should be checked prior to installation and use.

Natural Gas Fire Pit: Supply Pressure: Minimum: 6.0 inches W.C.; Maximum: 7.0 inches W.C.

LP Gas: Supply Pressure: Minimum: 8.0 inches W.C.; Maximum: 11.0 inches W.C.

! **DANGER** FLAMMABLE GAS UNDER PRESSURE.
 LEAKING LP-GAS MAY CAUSE A FIRE OR EXPLOSION IF IGNITED
 CAUSING SERIOUS BODILY INJURY OR DEATH.
 CONTACT LP GAS SUPPLIER FOR REPAIRS, OR DISPOSAL OF THIS CYLINDER
 OR UNUSED LP-GAS.

! **WARNING** FOR OUTDOOR USE ONLY.*
 DO NOT USE OR STORE CYLINDER IN A BUILDING,
 GARAGE OR ENCLOSED AREA.

WARNING:

Know the order of LP-gas. If you hear, see or smell leaking LP-gas, immediately get everyone away from the cylinder and call the Fire Department. Do not attempt repairs.

Caution your LP-gas supplier to:

- Be certain cylinder is purged of trapped air prior to first filling.
- Be certain not to over fill the cylinder.
- Be certain cylinder requalification date is checked.

LP-gas is heavier than air and may settle in low places while dissipating.

Contact with the liquid contents of cylinder will cause freeze burns to the skin.

Do not allow children to tamper or play with cylinder.

When not connected for use, keep cylinder valve turned off. Self contained appliances shall be limited to a cylinder of 30 lb capacity or less.

Do not use, store or transport cylinder where it would be exposed to high temperatures. Relief valve may open allowing a large amount of flammable gas to escape.

When transporting, keep cylinder secured in an upright position with cylinder valve turned off.

WHEN CONNECTING FOR USE:

Use only in compliance with applicable codes.

Read and follow manufacturer's instructions.

Consult manufacturer's instructions concerning the cylinder connection provided with your appliance.

Be sure regulator vent is not pointing up.

Turn off all valves on the appliance.

Do not check for gas leaks with a match or open flame. Apply soapy water at areas marked "X". Open cylinder valve. If bubble appears, close valve and have LP-gas service person make needed repairs. Also, check appliance valves and connections to make sure they do not leak before lighting appliance.

Light appliance(s) following manufacturer's instructions.

When appliance is not in use, keep the cylinder valve closed.

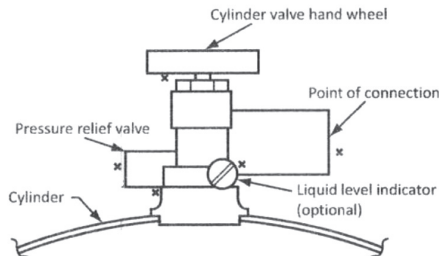

DO NOT REMOVE, DEFACE, OR OBLITERATE THIS LABEL
***EXCEPT AS AUTHORIZED BY ANSI/NFPA 58.**

! **DANGER:** Do not store a spare LP Cylinder under or near a barbecue grill, or other heat sources. NEVER fill an LP cylinder beyond 80% full: a fire causing death or serious injury may occur.

TABLE OF CONTENT

SAFETY INFORMATION

Warning Labels & Symbols.....002

SITE PREPARATION

Selecting A Information.....007

Electrical & Gas Supply Information.....008

Water Connection.....009

ASSEMBLY

Fire Feature Installation.....010

Enclosure Clearance.....012

Water Feature Installation.....013

Leveling Your Fire & Water Feature.....015

Electrical Wiring Schematic.....016

START-UP & TESTING

Gas Leak Test.....018

Start Up.....019

MAINTENANCE & TROUBLESHOOTING

Self-Contained Unit Maintenance.....022

Troubleshooting Guide.....023

Replacement Parts.....024

WARRANTY & SUPPORT

Customer Support Contact Information.....025

Warranty Information.....026



This product can expose you to chemicals including lead, which is known to the State of California to cause cancer and birth defects or other reproductive harm. For more information go to www.P65Warnings.ca.gov.

SELECTING THE LOCATION:

Choosing the right location for your Self-Contained Unit is crucial to ensuring a safe and enjoyable experience. Before you begin assembling your fountain, you should carefully consider the following factors when selecting a location:

- 1. Ventilation:** Some self-contained units have both fire & water features. If your unit has these both elements which require proper ventilation to prevent any harmful build-up of carbon monoxide or other gases. Always install the fountain in a well-ventilated area with plenty of fresh air flow.
- 2. Wind:** Avoid installing your self-contained unit in an area with high-winds, as this can cause safety hazards and negatively affect the performance of your unit.
- 3. Clearance:** The fire & water fountain should be installed in an area with enough clearance around it, free from any obstructions.
- 4. Water Source:** Make sure your chosen location has access to a reliable and adequate water source for the fountain's water feature.
- 5. Gas and Electrical Supply:** The Fire & Water Fountain requires a gas and electrical supply to operate, so ensure that the location you choose has easy access to these connections.
- 6. Level Surface:** A level surface is essential for proper installation and function of the fountain. Make sure the installation site is level, flat, and stable.
- 7. Visibility:** The Fire & Water Fountain is an impressive visual display, so choose a location that allows for maximum visibility, both for yourself and your guests.

CAUTION

The Fire & Water Fountain is a large and heavy structure that can create safety hazards if not placed in a suitable location. Always ensure that the fountain is installed on a stable and level surface and that there is enough clearance around the fountain for safe movement.

CAUTION

Failure to properly select a location for your Fire & Water Fountain can result in injury or property damage. If you are unsure about any aspect of the location selection process, consult a licensed professional for assistance.

ELECTRICAL & GAS SUPPLY

The Fire & Water Fountain requires both electrical and gas supplies to operate. It's important to ensure that both of these supplies are installed correctly to prevent any safety hazards or damage to the fountain.

Electrical Supply:

- 1. Voltage:** The Fire & Water Fountain requires a specific voltage to operate. Check page 001, to see the Wiring Diagram.
- 2. Outlet location:** The electrical outlet should be installed in a location that is easily accessible and is not too far from the fountain. It's important to avoid using extension cords or power strips as they can create safety hazards.
- 3. Ground Fault Circuit Interrupter (GFCI):** The electrical outlet should be installed with a GFCI to prevent electrical shocks. Ensure that the GFCI is working correctly before connecting the fountain.

GAS REQUIREMENTS:

The Fire & Water Fountain can be powered by either natural gas or propane, both gases are clean-burning fuels that produce low emission and are widely available. It is important to note that both natural gas and propane require special safety precautions to prevent gas leaks and ensure proper operation of the fountain. Proper installation, maintenance, and safety procedures must be followed when using either fuel to ensure the safe and reliable operation of the fountain.

120 VAC PRIMARY INPUT - 300 W OUTPUT

DISTANCE FEET	6AWG	8AWG	10AWG	12AWG
5FT	12VAC	12VAC	12VAC	12VAC
10FT	12VAC	12VAC	12VAC	13VAC
20FT	12VAC	12VAC	13VAC	13VAC
30FT	12VAC	13VAC	13VAC	14VAC
40FT	13VAC	13VAC	14VAC	
50FT	13VAC	13VAC	14VAC	
60FT	13VAC	14VAC		
70FT	13VAC	14VAC		
80FT	13VAC	14VAC		
90FT	14VAC			
100FT	14VAC			
110FT	14VAC			

GAS PRESSURE:

Natural Gas

Supply Pressure: Minimum 3.5" W.C. Maximum 7.0" W.C.
 Outlet Pressure: 3.5" W.C.

Liquid Propane

Supply Pressure: Minimum 8.0" W.C. Maximum 11.0" W.C.
 Outlet Pressure: 10.0" W.C.

ELECTRONICS:

- CSA Certified ANSI Z21.97-(2017) / CSA 2.41-(2017) certified
- If you plan to install your fire & water feature within 5 feet of water, the electrical supply **must be 12 or 14 VAC.**
- The Thermocouple Flame Sense operates by sensing the heat produced by the flame and producing an electrical signal to keep the gas valve open. In the event of a flame outage, the thermocouple sends a signal to close the gas valve, thereby stopping the gas supply and preventing the accumulation of gas that can lead to fire or explosion.
- The Low Voltage Electronic System features LEDdiagnostics that aid in field service and troubleshooting. The LED diagnostics display visual feedback on the electronic system's status, facilitating the identification and resolution of any problems that may arise.

GAS VALVES & PILOT COMPONENTS:

- All connectors are water resistant
- Certified CSA ANSI Z21.97-(2017) / CSA 2.41-(2017) certified.
- The Pilot is designed to have robust flame pattern that is wind-resistant.
- The coils are encapsulated to protect against moisture ensuring that the electrical components remain safe and operational.

WATER CONNECTION:

Connecting the water system on the Fire & Water Fountain is an important step in the installation process. The fountain uses a water supply line to provide water to the fountain and its components. It is important to ensure that the water supply line is properly installed and connected to a shut-off valve that can be easily accessed in case of an emergency. We recommend that you keep a copy of the checklist on hand throughout the installation process as a quick reference.

Use this checklist to ensure that the water system on your fire & water fountain is properly connected:

- Check that the water supply line is properly sized and installed.
- Ensure that the water supply line is connected to a shut-off valve that can be easily accessed in case of emergency.
- Locate the water inlet on the fountain's base.
- Connect the water supply line to the fountain's water pump using a hose connector.
- Turn on the water supply and check for any leaks or issues with water flow.
- Adjust the water pressure to the recommended level for the fountain.
- Regularly inspect the water supply line and connections for signs of wear or damage.
- Clean the water supply line and check the shut-off valve periodically.
- Inspect the water inlet for any clogs or blockages that could impact performance.

PROPER LOCATION:

Ensure that the fountain is located in an area that meets all local building and safety codes. Check for adequate ventilation, clearance from combustible materials, and appropriate electrical and gas connections.

 **WARNING**

For outdoor use only and must comply with instructions and clearances.

 **WARNING**

The water basin must be supplied power via GFCI protected circuits.

 **WARNING**

FIRE OPTION: For a water basin with the fire option refer to the correct fire pit installation instructions contained in this document.

 **IMPORTANT**

WARRANTY REQUIREMENTS: The Fire & Water Fountain must be installed in a location that meets all local building and safety codes, including adequate ventilation, clearance from combustible materials, and appropriate electrical and gas connections.

 **IMPORTANT**

WARRANTY REQUIREMENTS: The Fire & Water Fountain is a carefully designed and engineered product that should not be altered in any way. Any modification to the fountain may void the warranty. To ensure that your fountain is covered under warranty, please follow the installation and operation instructions provided in this manual. If you have any questions or concerns about the installation or operation of the fountain, please contact the manufacturer or a qualified professional. Failure to follow the instructions provided in this manual or any alterations made to the fountain will void the warranty.

Failure to meet any of these requirements may void the warranty. The manufacturer reserves the right to inspect the installation and determine whether it meets the warranty requirements.

PROPER VENTING:

The Fire & Water Fountain needs to have a proper venting system that ensure safe and efficient operation of the unit. The fountain uses a gas-powdered burner system to produce flames, which produce heat and carbon dioxide.

 **WARNING**

Improper venting of the Fire & Water Fountain can result in the buildup of harmful gases, which can be a serious safety hazard.

ELECTRICAL REQUIREMENTS:

NOTE: The Electronic Box is can only be operated using 12 Volts.

DO NOT attempt to power the Electronic Box using 110 Volts, it will damage the internal components.

RUNNING GAS LINE:

Installing a gas piping below your fire feature is recommended.

In order to ensure that gas flows smoothly and efficiently through a system, it is important to minimize pressure drop.

Reduce the length of the gas piping and the amount of elbows used. This will improve gas flow & better overall system performance.

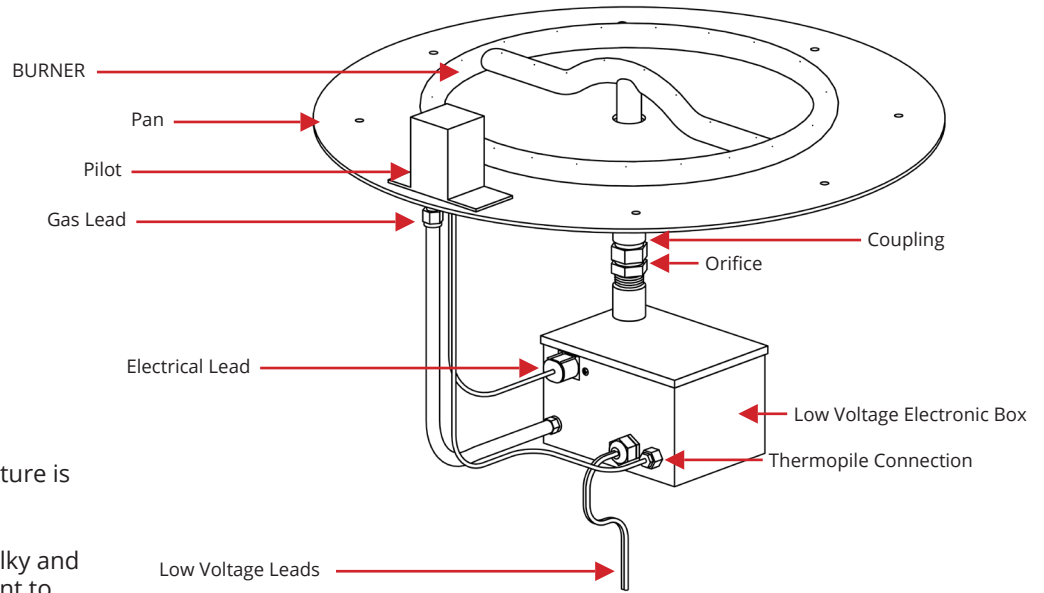

120 VAC PRIMARY INPUT - 300 W OUTPUT

DISTANCE FEET	6AWG	8AWG	10AWG	12AWG
5FT	12VAC	12VAC	12VAC	12VAC
10FT	12VAC	12VAC	12VAC	13VAC
20FT	12VAC	12VAC	13VAC	13VAC
30FT	12VAC	13VAC	13VAC	14VAC
40FT	13VAC	13VAC	14VAC	
50FT	13VAC	13VAC	14VAC	
60FT	13VAC	14VAC		
70FT	13VAC	14VAC		
80FT	13VAC	14VAC		
90FT	14VAC			
100FT	14VAC			
110FT	14VAC			

CLEARANCE AROUND FIRE PIT	
Under Valve Box when applicable for drainage	2"
Sides Surrounding Fire Pit From Structure or Combustibles	48"
Overhead Clearance above Product	96"

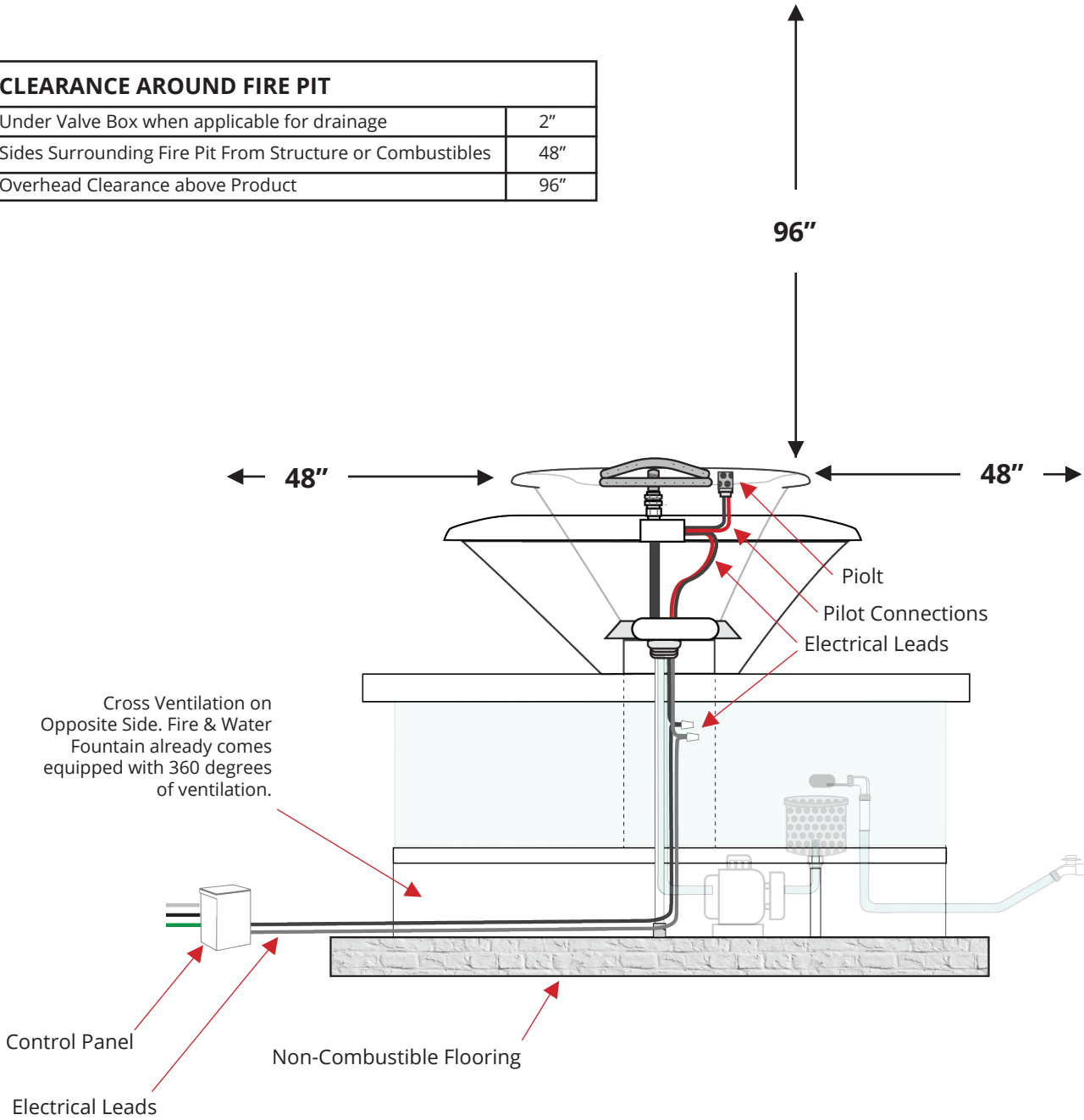

⚠ WARNING

Never lift the unit by the Bowl, Tower, or Ring. This will damage the unit.

⚠ CAUTION

Before connecting the water system, ensure that the fountain is completely dry and free of debris. Failure to do so can result in clogging or damage to the fountain's components

⚠ IMPORTANT

WARRANTY REQUIREMENTS: The Fire & Water Fountain must be constructed on a stable surface.

⚠ IMPORTANT

WARRANTY REQUIREMENTS: Adequate drainage is essential to prevent damage to surrounding surfaces in your chosen location. Please note that The Outdoor Plus does not provide a warranty against drips or leaks and assumes no responsibility for any damages. As the installer, it is your responsibility to ensure that there is sufficient drainage to enable maintenance, repair, winterization, or potential leaks from the water basin.

INSTALLING THE WATER FEATURE:

1. Install the pump, place it on a level surface below the water level. For future maintenance, it is recommended to install shut-off valves on both the inlet and outlet of the pump. The installation area should have sufficient floor drainage and the pump should be protected from excessive moisture. Ensure that there is enough access area to service both the pump and plumbing.

NOTE: Hand Tighten Unions Only!

DO NOT use a wrench or any adhesives or solvents!

DO NOT use wrong sealant. Use Teflon or approved sealing compounds for plastic. Wrong sealants can damage plastic. New installations need plumbing inspection. City water pressure is used for this test. Pressure should not exceed 40 PSI. Remove air from the system when pump and filter are under pressure. Be careful during the pressure test to avoid injury and voided warranties.

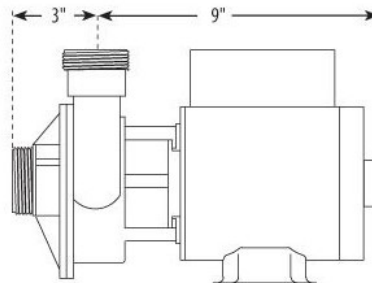
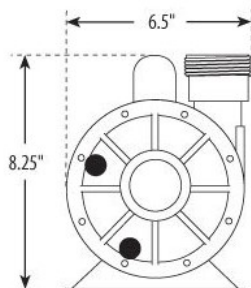

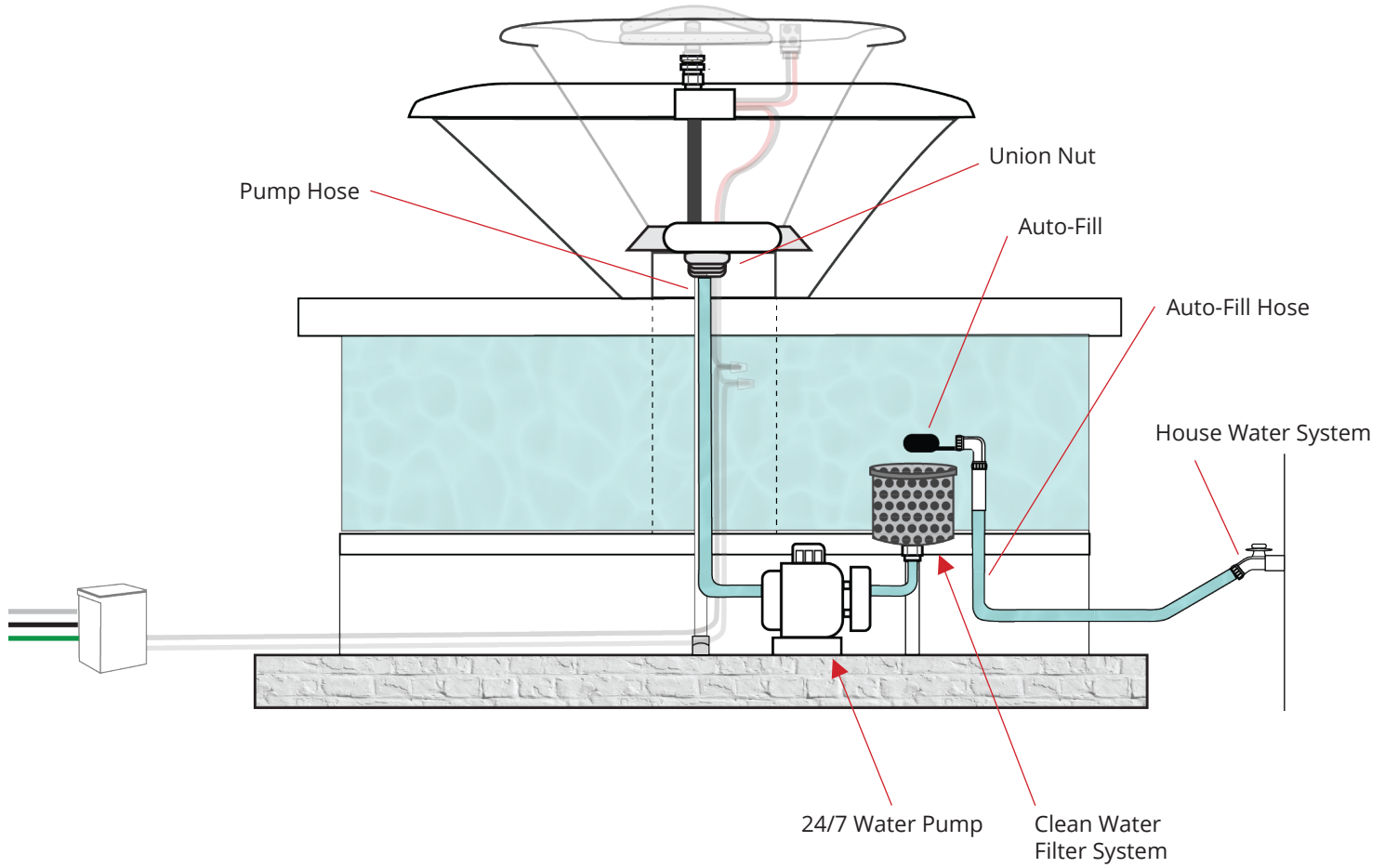

IMPORTANCE OF LEVELING:

It is important to your Fire & Water Fountain. When the fountain is not level, it can affect the overall appearance and functionality of the fountain. A sloping fountain can cause water to overflow in on area, leading to an unbalanced appearance.

You will need the following tools:



1. A Spirit Level



2. Shims



3. Measuring Tape



4. Rubber Mallet

Before starting any type of leveling - make sure your water and gas supply are Turned Off.

1. Start by removing any debris or dirt from the area you will be working on.
2. Place the fountain on a leveled area and check its balance using the Spirit Level. Check both horizontal and vertically levels to ensure the fountain is level in both directions. If needed follow steps 3-9, to safely add shims.

Adding Shims

3. If the fountain is not leveled. You can use sometype of shim, wooden or rubber shims work well. Start by removing any material under its base. Adjust the shims accordinly. Until the fountain gets leveled.
4. Once the fountain is level, check it again using the level tool to ensure that it is still balanced. Adjust as needed.

⚠ WARNING

Do not attempt to level the fountain by yourself. Always have at least two people present to avoid accidents and injury.

⚠ WARNING

Never attempt to level the fountain while it is in operation. Turn off all electrical and gas connections before beginning the leveling process.

ELECTRICAL SCHEMATIC OVERVIEW:

The Electrical Wiring Schematic is an essential component of the Fire & Water Fountain installation process. The schematic diagram illustrates the electrical connection and wiring for the Fire & Water Fountain, Lighting, and Ignition System.

It is important to note that only a qualified and licensed electrician should carry out the electrical wiring of the Fire & Water Fountain. They should have a good understanding of electrical systems and be able to read and interpret the schematic diagram.

Before starting the electrical wiring, the installer should ensure that the electrical power to the fountain is turned off. The wiring schematic is designed to ensure that the fountain operates safely and efficiently. It is crucial to note that any modifications or deviations from the wiring instructions provided in the manual could also void the manufacturer's warranty.

By following the wiring instructions provided, the installer can ensure that the fountain functions correctly and meets all necessary safety requirements. This can help to avoid potential hazards, including electric shock or other safety risks.

 **DANGER**

Electrical shock hazard. Only a qualified and licensed electrician should carry out the electrical wiring of the Fire & Water Fountain.

 **WARNING**

Do not attempt to perform any electrical work without disconnecting power to the fountain first. Failure to do so can result in serious injury or death.

 **CAUTION**

Modifications or deviations from the wiring instructions provided in the manual could void the manufacturer's warranty and create serious safety hazards. Always follow the wiring instructions carefully to ensure safe and proper operation of the fountain.

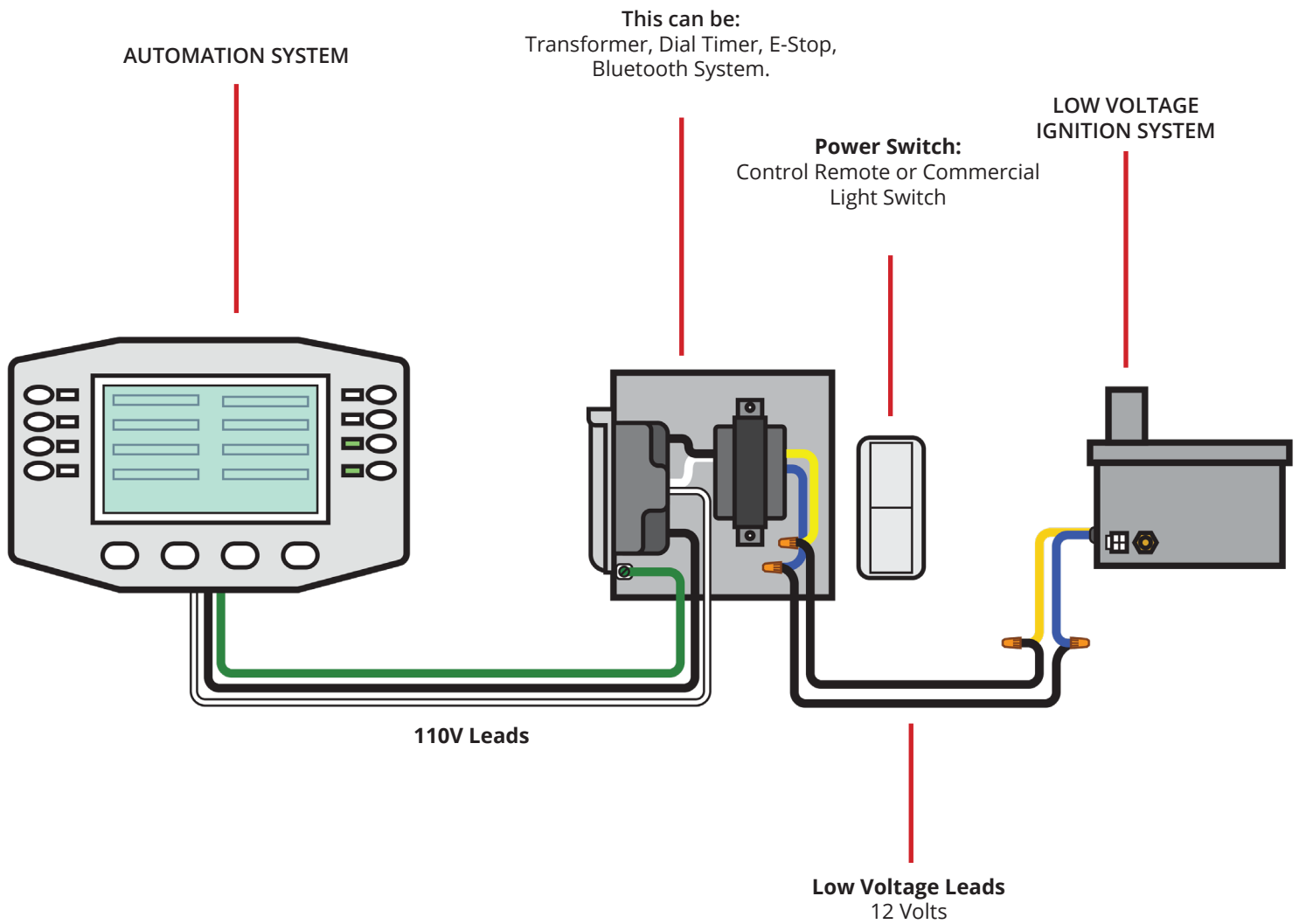

PERFORM A GAS LEAK TEST:

It is important to ensure that you conduct a gas leak test before starting your Fire Feature on your Self-Contained Unit.

Here a step-by-step guide on how to conduct a gas leak test on your unit:

Step 1: Turn off the Gas Supply

The first step is to turn off the gas supply to the fire and water fountain. It's important to make sure that the gas supply is completely turned off before proceeding to the next step.

Step 2: Make The Solution

Grab an empty container that can hold enough atleast 8oz of water. Apply inside the container both water and liquid soap. 1:1

Step 3: Apply The Solution

Using the solution (Soap & Water), apply a small amount to the connection point of the gas line. The solution will bubble up if there is a gas leak present.

Step 4: Check for Bubbles

If bubbles are present, this indicates a gas leak. If no bubbles are present, the connection is secure and there is no gas leak.

Step 5: Turn on the Gas Supply

Finally, turn on the gas supply to the fire and water fountain. Check for any gas leaks at the connection point once more. If no

OPERATING YOUR FIRE & WATER FOUNTAIN:

Before operating your fire feature ensure there is not any debris, leaves, or other combustible material. It is important to keep safety in mind, here are some quick tips for safely operating your fire & water fountain:

1. Keep the area clear of any combustible materials.
2. Never leave the Self-Contained Unit unattended
3. Never use other flammable materials such as gasoline or lighter fluid to start the fire.
4. Ensure there is always a fire extinguisher nearby in case of an emergency.
5. Keep children and pets away from the fountain when in use.
6. Regularly inspect and maintain the fountain and its components, including the gas line and electrical wiring, to ensure they are in good working condition.

POOL AUTOMATION (Start-Up):

If you are using a Pool Automation System to turn on your Fire Feature follow these steps:

1. Ensure your pool automation system is compatible with our Fire Feature, most automation systems are compatible with our Fire Features.
2. Once you have properly connected the pool automation to your fire feature, access the automation system's programming mode, and select fire feature as one of the controllable devices. Depending on your automation system you might need to put more information about the fire feature like BTU output. Read your automation system's manual to guide correctly install the Fire Feature Unit.
3. Once the fire feature has been added, you can schedule the self-contained unit to turn on to a set schedule, when an event occurs, or you can manually turn each feature on.

WARNING

Use of the pool automation system can be dangerous and result in injury or death if not used properly. Before using the pool automation system, carefully read and follow all manufacturer instructions and safety guidelines.

WARNING

Do not use the pool automation system if you are not familiar with its operation, or if you are not able to operate it safely. Always keep the system out of reach of children and pets.

WARNING

If you detect any issues with the pool automation system, including malfunctioning or abnormal behavior, immediately discontinue use and contact a qualified technician for assistance.

REMOTE CONTROL (Start-Up):

Always follow the manufacturer's instructions and safety guidelines when operating any kind of fire & water features. If you have any concerns or issues with the operation of your fire & water feature or remote control system, consult the manufacturer or a qualified technician for assistance. Follow these steps to properly pair your control remote unit.

1. Make sure that the gas and water supply to the fire & water feature are turned on and functioning properly. This will ensure that the feature is able to operate once it is turned on.
2. Turn on the Bluetooth system that is connected to the low voltage electronic box. Make sure that the system is paired with the remote control and that both devices are functioning properly.
3. Locate the button or switch on the remote control that is used to activate the fire & water feature. Depending on the specific remote control and system, this may be labeled or identified as the control for the feature.
4. Press the button or flip the switch to activate the fire & water feature. Depending on the specific system, you may need to hold the button down for a few seconds until the feature is fully activated and functioning.
5. Once the fire & water feature is activated, monitor it closely to ensure that it is operating safely and correctly. Make sure that the gas and water supply remain connected and functioning properly, and that there are no leaks or other issues.
6. When you are finished using the fire & water feature, use the remote control to turn it off. Make sure that the

 **WARNING**

Do not use the remote control if it is damaged or not functioning properly.

 **WARNING**

Keep the remote control out of reach of children and pets

 **WARNING**

Do not allow the remote control to become wet or submerged in water.

 **WARNING**

Make sure that the remote control is paired properly with the Bluetooth system and that both devices are functioning properly before use.

DIAL TIMER (Start-Up):

Always follow the manufacturer's instructions and safety guidelines when operating any kind of fire or water feature, and exercise caution when using a timer or other electronic device to activate it. If you have any concerns or issues with the operation of your fire & water fountain or timer system, consult the manufacturer or a qualified technician for assistance.

1. Ensure that the gas and water supply to the fire & water fountain are turned on and functioning properly. This will ensure that the fountain is able to operate once it is turned on.
2. Decide on the location for the dial timer. The timer can be mounted on the fire & water fountain unit itself if it is being built with non-combustible material. Alternatively, the timer can be mounted next to the house away from the fountain.
3. Follow the manufacturer's instructions for installation and make sure that the timer is securely mounted in the chosen location.
4. Set the timer to the desired start time for the fire & water fountain. Depending on the specific dial timer, this may involve adjusting the time of day or setting a specific duration for the fountain to run.
5. Once the timer is set, wait for it to activate the fire & water fountain at the designated start time. Depending on the specific timer, this may involve a mechanical switch or a digital signal being sent to the fountain.
6. Monitor the fire & water fountain closely to ensure that it is operating safely and correctly. Make sure that the gas and water supply remain connected and functioning properly, and that there are no leaks or other issues.
7. When you are finished using the fire & water fountain, use the dial timer to turn it off. Make sure that the fountain has fully cooled down before attempting to move or adjust it.

 **WARNING**

Do not use the dial timer if it is damaged or malfunctioning. This could result in unsafe operation of the fire & water fountain and could cause injury or damage.

 **WARNING**

Always ensure that the gas and water supply to the fire & water fountain are turned off before installing or adjusting the dial timer. Failure to do so could result in gas leaks, fire, or other hazards.

 **WARNING**

When setting the timer, ensure that the start time and duration are appropriate for the specific fire & water fountain unit. Do not set the timer to run for longer than recommended or to start at an unsafe time of day.

TAKING CARE OF YOUR SELF-CONTAINED UNIT:

It is important to properly maintain your Self-Contained Unit clean to ensure its longevity and safe operation. By regularly maintaining your unit it helps to prevent costly repairs, but also ensure that your fountain is always looking its best. Follow these steps to maintain your Fire & Water Fountain in good working condition:

1. **Keep it clean:** Regularly clean your Fire & Water Fountain to remove any debris or dirt that may accumulate on its surface. Use a soft-bristled brush or sponge to gently scrub the fountain, and rinse with clean water. Avoid using harsh cleaners or abrasive tools that can damage the fountain's finish.
2. **Check the gas and water connections:** Make sure to regularly check the gas and water connections to your Fire & Water Fountain to ensure they are tight and free of leaks. If you detect any leaks or damage to the connections, turn off the gas and water supply and contact a qualified technician to perform repairs.
3. **Inspect electronic components:** Periodically inspect the electronic components of the fountain, including the ignition system, control panel, and timer. Look for signs of damage or wear, and replace any damaged components as soon as possible to prevent unsafe operation.
4. **Keep an eye on water levels:** Ensure the water level in your Fire & Water Fountain is maintained at the proper level. Low water levels can cause the fountain to operate improperly or even become damaged.
5. **Schedule professional maintenance:** Regularly schedule a qualified technician to perform maintenance on your Fire & Water Fountain at least once a year, or more frequently if you notice any issues or concerns.
6. **Protect it from the elements:** Cover your Fire & Water Fountain during inclement weather to protect it from damage. Additionally, make sure to drain the fountain and turn off the gas supply during the winter months to prevent damage from freezing temperatures.

WINTERIZE YOUR UNIT:

If you live in a colder climate like the Midwest or East Coast, it's important to properly winterize your Fire & Water Fountain to prevent any damage from freezing temperatures. Here is a step-by-step guide on how to properly winterize your unit:



1. **Turn off the water supply:** Locate the water shutoff valve for your Fire & Water Fountain and turn it off. This will prevent any water from flowing into the fountain and freezing.
2. **Drain the fountain:** Once the water supply is turned off, use a submersible pump or a wet/dry vac to remove all of the water from the fountain. Make sure to also drain any water from the supply line.
3. **Disconnect and drain the hoses:** If your Fire & Water Fountain is connected to a hose or any other external water source, disconnect and drain the hose. Store the hose in a dry, indoor location to prevent any damage.
4. **Turn off the gas supply:** Locate the gas shutoff valve for your Fire & Water Fountain and turn it off. This will prevent any gas from flowing into the fountain.
5. **Drain the gas line:** Once the gas supply is turned off, use a wrench to disconnect the gas line from the fountain. Use a rag or towel to catch any excess gas that may leak out. Store the gas line in a dry, indoor location.
6. **Cover the fountain:** Use a waterproof cover to protect your Fire & Water Fountain from any snow, ice, or other winter weather. Make sure the cover is secured tightly to prevent any moisture from getting inside.

PROBLEM	POSSIBLE CAUSES	SOLUTION
WATER IS NOT TURNING ON	<ol style="list-style-type: none"> 1. Not enough water. 2. No Power 3. Breaker Tripped 4. Defective Pump 	<ol style="list-style-type: none"> 1. Add more water 2. Ensure there is power running to the unit 3. Reset breaker on electrical control box 4. Replace Pump
LIGHTS ARE NOT TURNING ON	<ol style="list-style-type: none"> 1. Defective Lights 2. LED BOX Defective 3. No Power 4. Breaker Tripped 	<ol style="list-style-type: none"> 1. Replace LED 2. Replace LED Box 3. Ensure there is power running to the LED 4. Reset breaker on electrical control box
WEAK WATER FLOW	<ol style="list-style-type: none"> 1. Dirty Filter 2. Ball Valve 3. Defective Pump 	<ol style="list-style-type: none"> 1. Clean filter 2. Closed open ball valve on the outlet side of pump 3. Replace Pump
WATER LEVEL TO LOW	<ol style="list-style-type: none"> 1. Overflowing due to a clog. 	<ol style="list-style-type: none"> 1. Clean the fountain
BURNER WILL NOT LIGHT	<ol style="list-style-type: none"> 1. Air in gas line 2. No gas flow 	<ol style="list-style-type: none"> 1. Bleed air from gas line by slowly opening valve 2. Possible debris in line - Clean the line.
BURNER WILL NOT STAY LIT	<ol style="list-style-type: none"> 1. Gas Pressure Improper 2. Burner obstructed 3. Too much media 4. Too windy 	<ol style="list-style-type: none"> 1. Confirm proper gas pressure 2. Ensure there is no debris in the burner 3. Re-apply media 4. Use when it's less windy.
LOW FLAME WHEN TURNED ON	<ol style="list-style-type: none"> 1. Gas Pressure Improper 2. (NG) undersized gas supply. 3. Lack of gas 4. Gas hose is pinched 	<ol style="list-style-type: none"> 1. Confirm proper gas pressure 2. Gas line must be sized to deliver fire pit input pressure 3. Check gas level of LP tank 4. Reposition supply hose
FLAME CREATE LOTS OF SOOT	<ol style="list-style-type: none"> 1. Venturis might be blocked with debri. 	<ol style="list-style-type: none"> 1. Clean out the venturi.
NOISE WHEN LIT	<ol style="list-style-type: none"> 1. Whistling Noise 2. Humming Regulator 	<ol style="list-style-type: none"> 1. Reduce the hose bend. 2. Normal - due to Hot Days.

FOUNTAIN REPLACEMENT PARTS:

 <p>WATER PUMP OPT-RP-WPMP</p>	 <p>AUFO-FILL OPT-AUTORF</p>	 <p>FILTER CARTRIDGE OPT-RP-FCRT</p>	 <p>DRAIN VALVE OPT-RP-DRV</p>	 <p>HOUSING KIT OPT-RP-LEDHU</p>	 <p>LED LIGHT OPT-RP-LEDLF</p>
 <p>LED MODULE OPT-RP-LEDMD</p>	 <p>TRANSFORMER OPT-RP-LED12V</p>	 <p>UNION NUT OPT-RP-UNT</p>			

FIRE FEATURE REPLACEMENT PARTS:

 <p>LOW VOLTAGE COMPLETE KIT TOP-500EIS-100-12</p>	 <p>ELECTRICAL LEADS KIT OPT-PIEXT</p>	 <p>PILOT OPT-500PI</p>
--	--	---

At The Outdoor Plus, we are committed to providing excellent customer service to all of our customers. If you need assistance in ordering parts for your Fire & Water Fountain, please contact our sales team at: **sales@theoutdoorplus.com** Our knowledgeable sales team can assist you in identifying the correct parts and accessories needed for your fountain.

If you need assistance in installing your Fire & Water Fountain, please contact our support team at: **support@theoutdoorplus.com**. Our team of experts can provide guidance and assistance to ensure a safe and successful installation.

We are dedicated to making your experience with The Outdoor Plus as seamless and enjoyable as possible. Don't hesitate to reach out to us with any questions or concerns you may have. Our team is always ready to assist you in any way we can.

REGISTER YOUR FIRE & WATER FOUNTAIN:

Thank you for choosing The Outdoor Plus for your fire and water feature needs. We hope that your product has exceeded your expectations and has provided you with countless hours of enjoyment.

We would like to remind you of the importance of registering your product online. By doing so, you will receive the most efficient and helpful service should you ever need to use your product warranty. Our registration process is quick and easy, and it will help us to better serve you in the future.

Thank you again for choosing The Outdoor Plus, and we hope to continue serving you for many years to come.

SCAN TO REGISTER YOUR PRODUCT ONLINE:



The Outdoor Plus Company (TOP) warranties fire pits against manufacturing defects that prevent safe and correct function as follows: Warranty periods are as follows:

Electronics, Gas Valves, & Pilot Assembly:

Commercial - 6 Months ; Residential - 1 Year

Stainless Steel & Aluminum Pans:

Commercial - 6 Months ; Residential - 1 Year

Burner Ring & Burner Bars:

Lifetime Warranty

Electrodes & Spark Igniter Components

Not Warrantied (due to lifespan)

- Warranty starts from the original sale/shipment date from The Outdoor Plus.
- Warranty only applies to claims made by T.O.P's original customer and replaces all other warranties expressed or implied.
- Defective products must be returned to TOP with an RMA issued by TOP and original purchase information is required.
- RMA is only valid for 30 days and must be indicated on the outside of the return package with a copy placed inside.
- TOP is not responsible for shipping damage, surface level rust, or actions of the installer.
- Labor involving installation or maintenance is not covered.
- This warranty excludes claims for incidental or consequential damage and indirect collateral expenses arising from product defects or warranty recovery.
- Product cannot be altered or modified in any way if it is cLCus, UL, or CSA certified.
- TOP is not responsible for local codes and will not accept a return on any product not approved for installation. Check with local authorities for proper approvals before purchasing.

PRODUCT RETURN POLICY

No returns on made-to-order goods.

No returns on custom features, NO EXCEPTIONS.

If a product is delivered incorrectly, it is the recipients responsibility to notify TOP within 48 hours. TOP is not responsible for incorrect or damaged packages and shipments 48 hours after they have been received.

Please call (909) 460-5579 or email: support@theoutdoorplus.com for help with warranty, replacements, returns, or if you have any support related questions.

PRODUCT TESTING PROGRAM

If you suspect that a unit or component you received is defective, you can send it to The Outdoor Plus for testing at their facility. The Outdoor Plus will cover the shipping costs for sending the component back to you.

DEFECTIVE

If a product is found to be defective, T.O.P will repair or replace it at their discretion. If the product is under warranty, T.O.P will cover all costs associated with outgoing freight and replacement.

NON-DEFECTIVE

If the product is determined to be non-defective, it will be returned to the customer, and no credit will be issued.

TOP ERROR

If T.O.P makes a mistake and a return is required, we will provide an RMA and Return Services Label. Once we receive the products at T.O.P, we will issue a credit for the products and the outgoing freight on the original invoice.

CUSTOMER ERROR

If a Return Merchandise Authorization (RMA) is requested for new products in their original packaging, we will authorize the return. However, the customer will be responsible for the shipping cost of the return. Once we receive the products, we will issue a credit for the original cost of the products, minus a 25% restocking fee. Please note that custom orders are exempt from this policy.

FREIGHT POLICY

All orders will be shipped Freight on Board (FOB) Ontario, California, with a standard shipping carrier selected by TOP unless the customer specifically requests their own carrier and account. A freight quote may be requested in advance. TOP works diligently with standard carriers to achieve the best discounts available.

CONGRADULATIONS!

We wanted to take a moment to extend our sincere gratitude for choosing The Outdoor Plus for your recent Fire & Water Fountain purchase. We hope that it will provide many years of enjoyment.

Our team takes great pride in crafting each unit with the utmost attention to detail and precision, and we are delighted to hear that you appreciate the hard work and craftsmanship that has gone into making your fountain.

Thank you for your purchase and trust in our products. If you have any questions or concerns, please do not hesitate to reach out to us. We are always here to help.



THE OUTDOOR PLUS

USA MANUFACTURER OF FIRE & WATER PRODUCTS

THE OUTDOOR PLUS

701 S DUPONT AVE
ONTARIO, CA 91761

Contact Information:

Phone: (909) 460 5579
Sales: sales@theoutdoorplus.com
Support: support@theoutdoorplus.com

