

# 50" PORTABLE INTERACTIVE BASKETBALL HOOP

## INSTRUCTION MANUAL

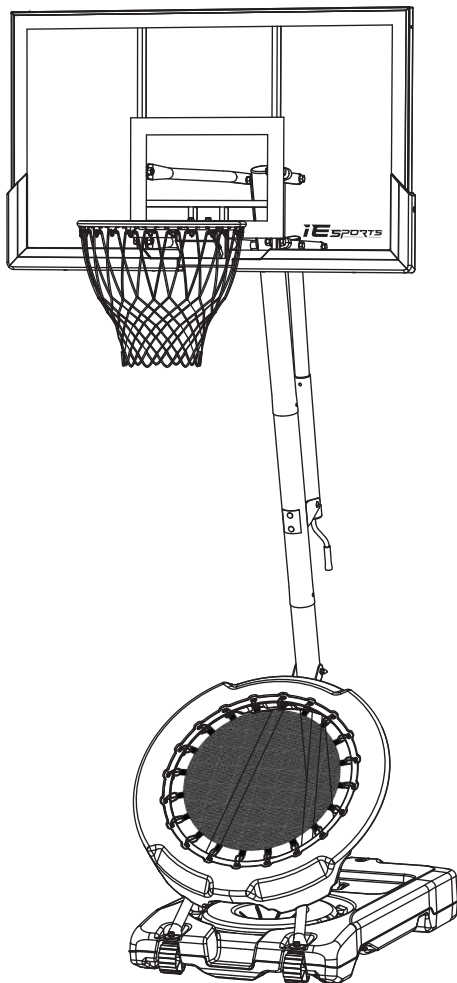

Installation Video



**STYLE/MODEL NUMBER**  
**Portable Basketball Hoop**  
**Item No.: 50IEF1**

Save these instructions for future reference. For assistance:

**Customer Service Mailbox: [info@ie-sport.com](mailto:info@ie-sport.com)**  
**Customer Service Number: 909-966-9015**

Hours of Operation: Mon-Sat 10:00am - 4:00pm EDT (9:00am - 3:00pm EST)

**INNOVATIVE ENTERPRISE(US) 3647 De Forest Cir, Mira Loma, CA 91752**



**⚠ WARNING!**

READ AND UNDERSTAND  
OPERATOR'S MANUAL BEFORE  
USING THIS UNIT.

FAILURE TO FOLLOW OPERATING  
INSTRUCTIONS COULD RESULT IN  
INJURY OR DAMAGE TO PROPERTY.

# POLE CARE AND SYSTEM MAINTENANCE

The life of your basketball hoop depends on many variables. The climate, exposure to corrosives such as salt, pesticides or herbicides, and excessive use, or misuse can all contribute to product damage, which may cause personal injury. Check your basketball hoop frequently for loose hardware, excessive wear, and signs of corrosion. For safety reasons, and to extend the life of your basketball hoop, you must take the following preventative measures:

1. Check all nuts and bolts. If any are loose, tighten them.
2. Check all parts for excessive wear and tear. If necessary, replace any parts that have been worn or damaged through usage.
3. Check all parts for visible rust, chips, or cracked paint. If any are present, do the following:
  - a) Use an emery cloth to completely remove any rust or chipped paint.
  - b) Clean the area with a damp cloth and allow it to dry.
  - c) Spray two coats of rust preventative, high gloss enamel paint on the area.

IF RUST HAS PENETRATED THROUGH THE POLE ANYWHERE, REPLACE THE POLE IMMEDIATELY!

## **WARNING!!!**

NEVER PLAY WITH THE PORTABLE BASKETBALL SYSTEM WITHOUT FILLING UP THE BASE WITH WATER AND/OR SAND FULLY, AS THE SYSTEM MAY TIP OVER CAUSING INJURIES.

## **SAFETY INSTRUCTIONS**

- DO NOT HANG on the rim or any part of the hoop, including backboard, support braces, or net.
- During play, keep the player's face away from the backboard, rim, and net. Serious injury could occur if teeth/face come in contact with a backboard, rim, or net.
- Only adults should adjust or move the basketball hoop. When adjusting the height or moving the hoop, keep hands and fingers away from moving parts.
- Always check the unit to ensure that the base is full of water and/or sand, all nuts, bolts and hardware are tight before each use.
- The surface beneath the base must be smooth and free of gravel or other sharp objects. Punctures cause leakage and could cause the device to tip over.
- Do not allow water to freeze in the base if it is full of water.
- Two adults are required to complete the installation.
- Use extreme caution if placing the hoop on a sloped surface. The hoop may tip over more easily.
- Keep this manual for future reference.



# SAFETY INSTRUCTIONS



FAILURE TO FOLLOW THESE SAFETY INSTRUCTIONS MAY RESULT IN SERIOUS INJURY AND/OR PROPERTY DAMAGE.

Owner must ensure that all players know and follow these rules for safe operation of the Basketball Hoop.

To ensure safety, do not attempt to assemble this Basketball Hoop without following the instructions carefully. Check entire box and inside all packing material for parts and/or additional instruction material. Before beginning assembly, read the instructions and identify parts using the hardware identifier and parts list in this document. Proper and complete assembly, use, and supervision are essential for proper operation and to reduce the risk of accident or injury. A high probability of serious injury exists if this Basketball Hoop is not installed, maintained and operated properly.

- If using a ladder during assembly, use extreme caution.
- 2 capable adults are recommended for this operation.
- Check base daily for leakage. Leaks could cause system to fall.
- Assemble the pole sections properly. Failure to do so could cause the pole sections to separate during play or transport.
- Operational height is 7.5ft (2.28m) to 10ft (3.05m) from the ground to the rim.

*Most injuries are caused by misuse and/or not following instructions. Use caution when using this unit.*

## WARNING TO INSTALLERS

Two capable adults are required for installation. The base MUST be filled with sand and/or water at all times. The entire basketball hoop must be installed according to instructions. Failure to follow instructions could result in SERIOUS INJURY. It is NOT recommended to create a temporary support for the device.



# WARNING



**FAILURE TO FOLLOW THESE WARNINGS MAY RESULT IN SERIOUS INJURY AND/OR PROPERTY DAMAGE.**

**Owner must ensure that all players know and follow these rules for operation of the system.**

- Only hang from the rim briefly to regain balance or avoid injuring others. Release the rim as safely as possible.
- During play, especially when performing dunk-type activities, keep player's face away from the backboard, rim and net. Serious injuries could occur if teeth/face come in contact with backboard, rim, or net.
- Do not slide, climb, or play on base or pole.
- Completely fill base according to manufacturer's instructions or the system will tip quickly causing serious personal injury.
- When adjusting height or moving system, keep hands and fingers away from moving parts.
- Do not allow children to move or adjust system.
- During play, do not wear jewelry (rings, watches, necklaces, etc.). Objects may entangle in net.
- Surface beneath the base must be smooth and free of gravel or other objects.
- Punctures can cause leakage and could cause system to tip over.
- Keep water and organic materials away from pole. Pole can rust and fall.
- Once a month, check pole and all metal parts for rust. Completely remove rust and repaint with exterior enamel. If rust has penetrated any steel part, replace that part immediately.
- Check system before each use for proper ballast, loose hardware, instability, and signs of corrosion and repair before each use. Never play on damaged equipment.
- Do not use system during windy or severe weather. System may tip over. Place system in an area protected from the wind or in an area away from property that may be damaged if the system falls.
- Do not leave unit in vertical position if the base is not properly filled with water and/or sand.
- This product is NOT designed to support a player hanging from any component of this basketball system.
- Rim height adjustments should be made by ADULTS ONLY.
- Wear a mouth guard when playing to avoid dental injuries.

**Customer Service Mailbox: [info@ie-sport.com](mailto:info@ie-sport.com)  
Customer Service Number: 909-966-9015**

Hours of Operation: Mon-Sat 10:00am - 4:00pm EDT (9:00am - 3:00pm EST)



## WARNING:

Failure to observe this warning may cause property damage and/or serious injury.

This product is NOT designed to support a player hanging from any component of this basketball system.

Rim height adjustments should be made by ADULTS ONLY.

Wear a mouth guard when playing to avoid dental injuries.

During play, do not wear jewelry (rings, watches, necklaces, etc.).

Objects may entangle in net.



**WARNING:**

**SWINGING ON THIS RIM  
MAY CAUSE SERIOUS  
INJURY OR DEATH.**



**WARNING:**

**DO NOT LEAVE UNIT IN VERTICAL  
POSITION IF THE BASE IS NOT  
PROPERLY FILLED WITH WATER  
AND SAND.**



# WARNING



## FAILURE TO FOLLOW THESE WARNINGS MAY RESULT IN SERIOUS INJURY AND/OR PROPERTY DAMAGE.

**Owner must ensure that all players know and follow these rules for operation of the system.**

- Only hang from the rim briefly to regain balance or avoid injuring others. Release the rim as safely as possible.
- During play, especially when performing dunk-type activities, keep player's face away from the backboard, rim and net. Serious injuries could occur if teeth/face come in contact with backboard, rim, or net.
- Do not slide, climb, or play on base or pole.
- Completely fill base according to manufacturer's instructions or the system will tip quickly causing serious personal injury.
- When adjusting height or moving system, keep hands and fingers away from moving parts.
- Do not allow children to move or adjust system.
- During play, do not wear jewelry (rings, watches, necklaces, etc.). Objects may entangle in net.
- Surface beneath the base must be smooth and free of gravel or other objects.
- Punctures can cause leakage and could cause system to tip over.
- Keep water and organic materials away from pole. Pole can rust and fall.
- Once a month, check pole and all metal parts for rust. Completely remove rust and repaint with exterior enamel. If rust has penetrated any steel part, replace that part immediately.
- Check system before each use for proper ballast, loose hardware, instability, and signs of corrosion and repair before each use. Never play on damaged equipment.
- Do not use system during windy or severe weather. System may tip over. Place system in an area protected from the wind or in an area away from property that may be damaged if the system falls.
- Do not leave unit in vertical position if the base is not properly filled with water and/or sand.
- This product is NOT designed to support a player hanging from any component of this basketball system.
- Rim height adjustments should be made by ADULTS ONLY.
- Wear a mouth guard when playing to avoid dental injuries.
- Adjust backboard to lowest position. While holding pole and lifting base, carefully lean system forward until wheels touch ground. While holding pole and base, roll system to desired location. Stand pole upright and set base flat on ground. ALWAYS check to make sure system is stable in new location.

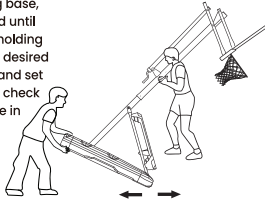

### **WARNING!**

Treading on base may cause leakage, and the system would tip over.



### **WARNING!**

This backboard and rim is not designed to support a player hanging from the rim or net.



### **WARNING!**

This backboard and rim is not designed to support a player hanging from the rim or net.



### **WARNING!**

Treading on base may cause leakage, and the system would tip over.

# Parts List

**A** Base  
1 pc

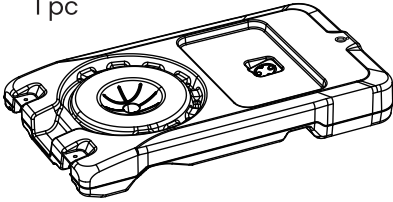

**B** Wheel & Axle  
2 pcs      2 pcs



Pre-installed on Base

**E** Bottom Pole Brace  
2 pcs

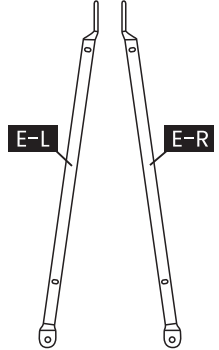

**C** Bottom Pole  
1 pc

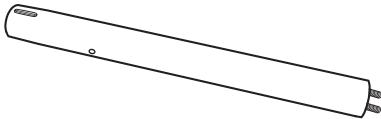

**D** Round Plate  
1 pc



IN BAG-1

**F** Rebounder  
1 pc

Mesh Fabric  
1 pc  
Elastic Rope  
20 pcs

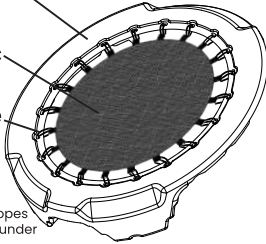

Mesh Fabric, Elastic Ropes  
Pre-installed on Rebounder

**G** Middle Pole  
1 pc

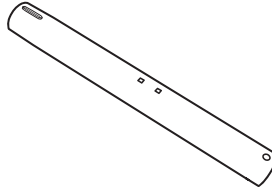

**H** Middle Pole  
Mounting Plate  
1 pc

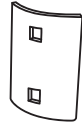

IN BAG-5

**I** Middle Pole  
Mounting Plate  
1 pc

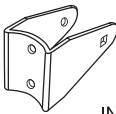

IN BAG-5

**J** Lower Lifting Tube  
2 pcs

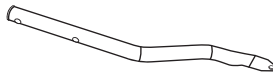

**K** Upper Lifting Tube  
2 pcs

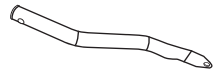

**L** Backboard  
1 pc

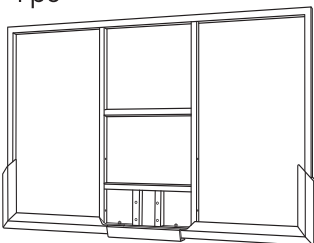

**M** Top Pole  
1 pc

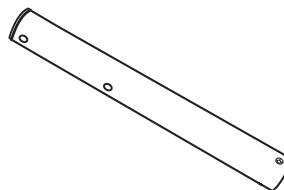

**N** Triangle  
Connecting Plate  
1 pc

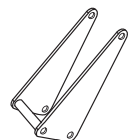

IN BAG-3

**O** Height Adjustment Assembly  
1 pc

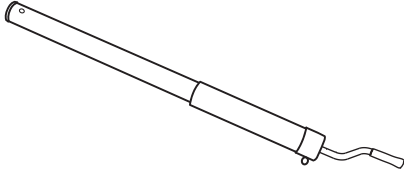

**P** Rim  
1 pc

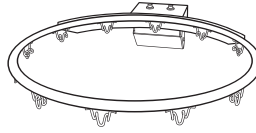

**Q** Net  
1 pc

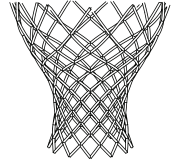

## Small Part Bags (Bolts & Screws)

### BAG-1

Socket Wrench X1

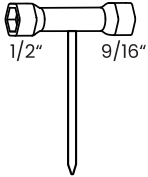

Wrench x2

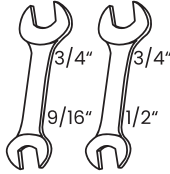

**D** Round Plate  
1 pc

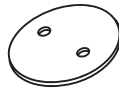

**1** 

2 pcs Black Self Tapping Screw  
M6x0.63 Long



2 pcs Black Plastic Washer

**2** 

2 pcs Lock nut, 5/16-18



2 pcs Washer, 5/16

### BAG-2

**3**

 1 pc Bolt, 5/16-18x3.62 Long



1 pc washer, 5/16



1 pc Nut, 5/16-18

**4**

 2 pcs Bolt, 3/8-16x0.79 Long



2 pcs washer, 3/8

**5**

 4 pcs Bolt, 5/16-18x1.89 Long



4 pcs washer, 5/16

### BAG-3

**6**

 1 pc Bolt, 1/2-13x3.98 Long



2 pcs washer, 1/2



1 pc Nut, 1/2-13

**9**

 3 pcs Bolt, 1/2-13x8.39 Long



6 pcs washer, 1/2



3 pcs Nut, 1/2-13

**7**



4 pcs Plastic Spacer, 0.87 Long

**N** Triangle Connecting Plate  
1 pc

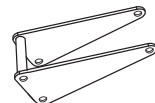

**8**



2 pcs Plastic Spacer, 1.61 Long

## BAG-4

10



4 pcs Bolt, 1/2-13x2 Long



8 pcs washer, 1/2



4 pcs Nylon washer, 1/2



4 pcs Lock nut, 1/2-13

11



4 pcs Bolt, 5/16-18x1.77 Long



4 pcs washer, 5/16



4 pcs Lock washer, 5/16

## BAG-5

12



2 pcs Bolt, 5/16-18x3.62 Long



2 pcs washer, 5/16



2 pcs Lock nut, 5/16-18

I

Middle Pole Mounting Plate  
1 pc

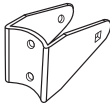

13



1 pc Bolt, 5/16-18x2.76 Long



1 pc washer, 5/16



1 pc Nut, 5/16-18

H

Middle Pole Mounting Plate  
1 pc

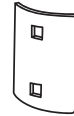

## Required Tools And Materials

The following required tools are **NOT INCLUDED**.



• 2 Capable Adults



• Sawhorse or Support Table  
(Suggested height is above 32.5 inch)



• Sand funnel



• Safety Glasses



• Garden Hose  
or Sand

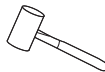

• Wooden Hammer  
or Rubber Hammer

You can use our free tools for assembly, or you can use your own handy tools.



**AND/OR**



• (2 each) Wrenches and/or Socket Wrenches and  
Sockets (Deepwell Sockets are Recommended)

1/2" 9/16"

1/2"

9/16"



# STEP 1

Insert Pole (C) into Pole (G). Align the Hole in Pole (G) with the Slot in Pole (C).  
Install Screw set (1) of **BAG-1** through the Hole and the Slot. Do not tighten the screw at this point.  
Place the installed pole on a board straight up. Hit the Pole (C,G) on the wooden Board or Thick Cardboard six to seven times. Tighten the screw (1) when the Pole (G) reached the marked line of Pole (C). The marked line is for installation reference only. Hit the poles on a hard surface six to seven times is required.

## WARNING:

- Ensure the Hole is aligned with the Slot. Failure to do so may result in a slanted backboard.
- Do not hit your feet with the pole, as serious injury could occur.

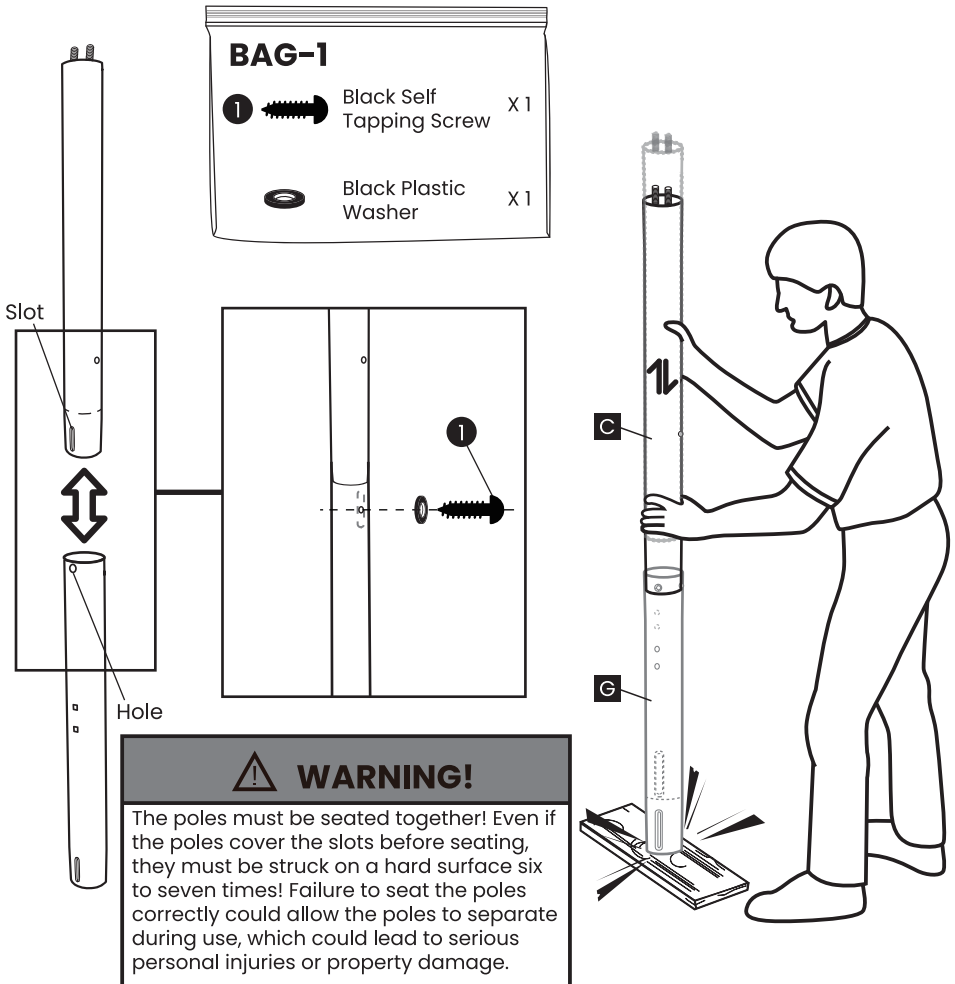

# STEP 2

Insert Pole (C,G) to Pole (M). Align the Hole in Pole (M) with the Slot in Pole (C,G). Install Screw set (1) of **BAG-1** through the Hole and the Slot. Do not tighten the screw at this point. Place the installed pole on a board straight up. Hit the Pole (C,G,M) on the wooden Board or Thick Cardboard six to seven times. Tighten the screw (1) when the Pole (M) reached the marked line of Pole (G). The marked line is for installation reference only. Hit the poles on a hard surface six to seven times is required.

## WARNING:

- Ensure the Hole is aligned with the Slot. Failure to do so may result in a slanted backboard.
- Do not hit your feet with the pole, as serious injury could occur.

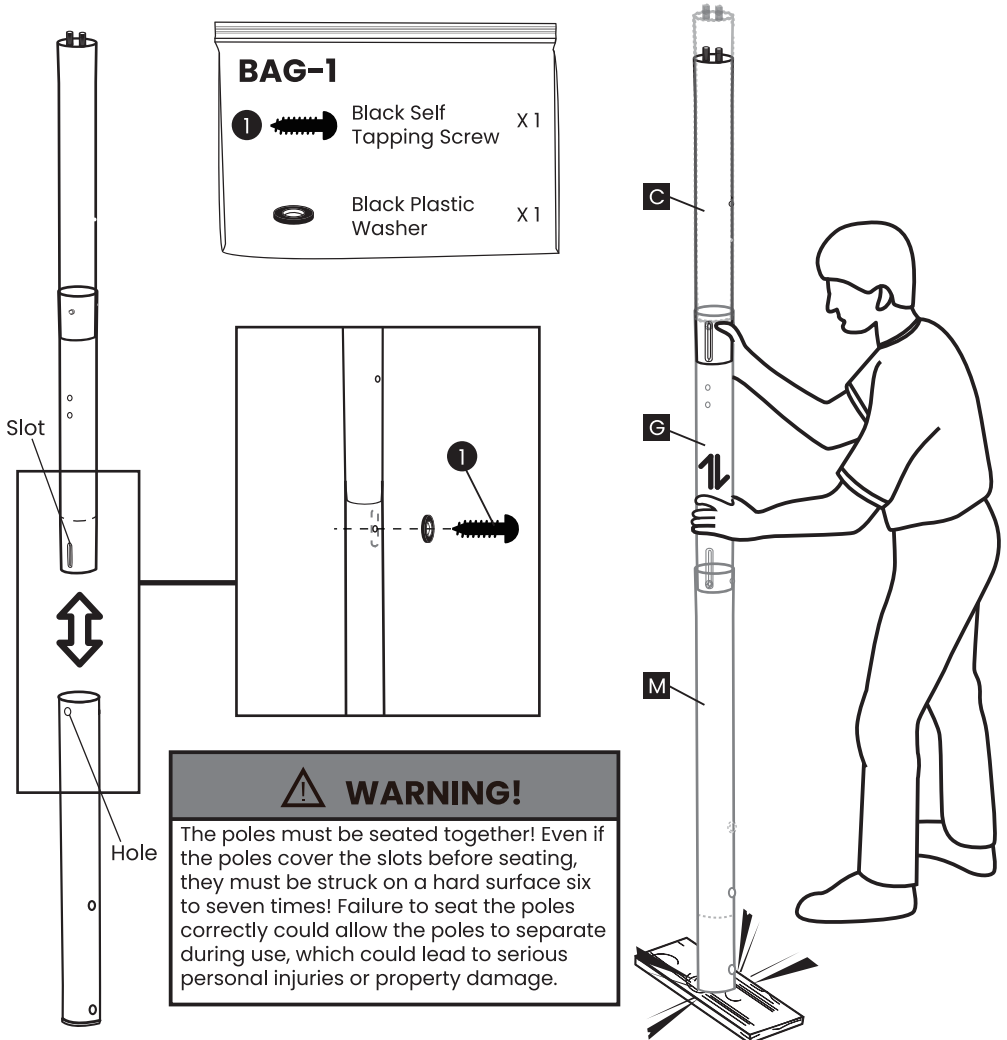

# STEP 3

Install the pole section (C,G,M) onto Base (A). Align the two preinstalled bolts through two holes of Base (A). Connect the pole section (C,G,M) to Round Plate (D) with Screw set (2) in **BAG-1**.

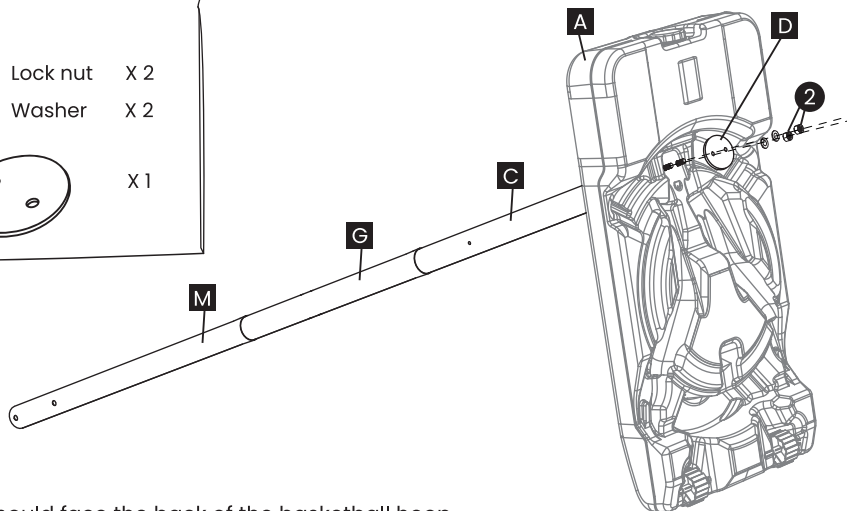
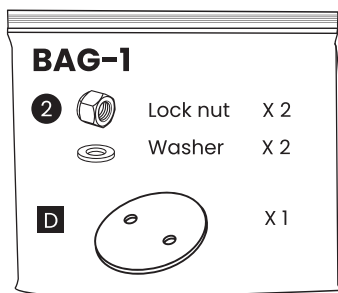

## Attention:

- The Hole should face the back of the basketball hoop.

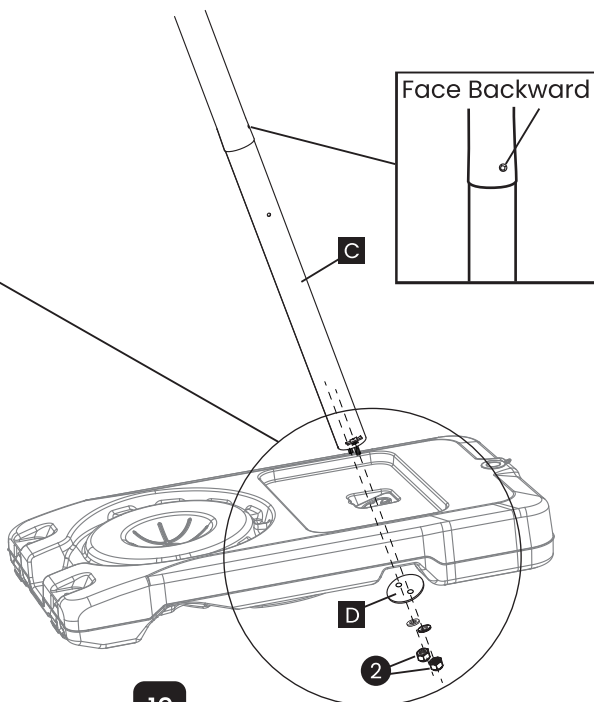
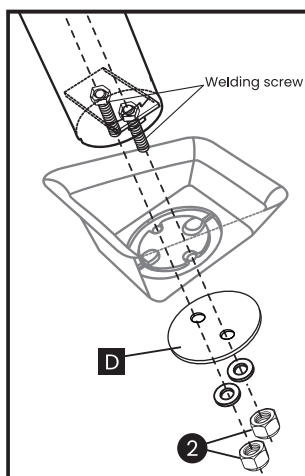

# STEP 4

Install Bottom Pole Brace (E) on the Rebounder (F) with Screw set (5) in **BAG-2**. Do not tighten the screws at this point. Make sure that the left brace and the right brace are installed in the correct position.

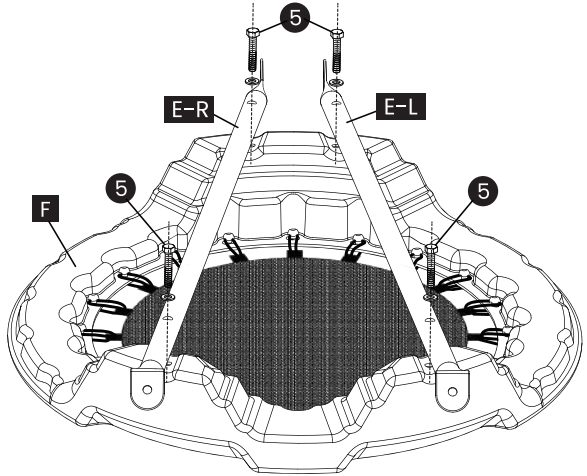
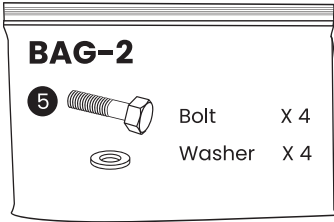

# STEP 5

Install the Rebounder onto the base and poles as shown. Connect the Rebounder to Pole (C) with Screw set (3) in **BAG-2**. Connect the Rebounder to Base (A) with Screw set (4) in **BAG-2**. When the Rebounder is in place, tighten all the screws (5) of the Rebounder.

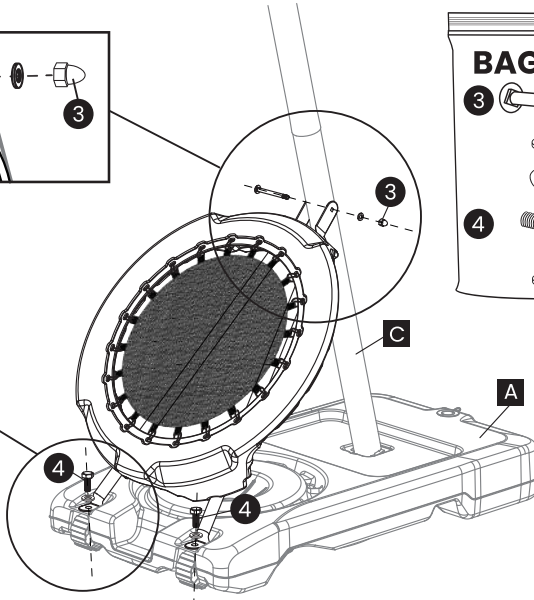
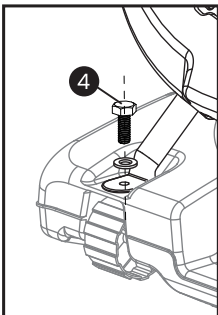
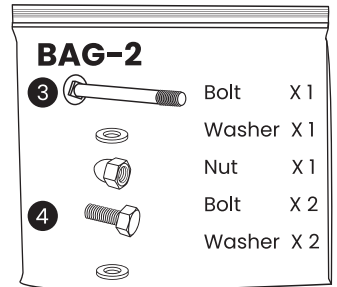
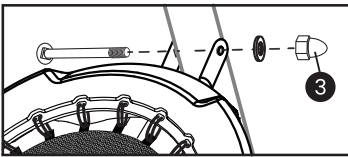

# STEP 6

Place the Basketball Hoop base with pole on a sawhorse or a work table carefully. Install the Triangle Connecting Plate (N) to Top Pole (M) with Screw set (6) in **BAG-3**.

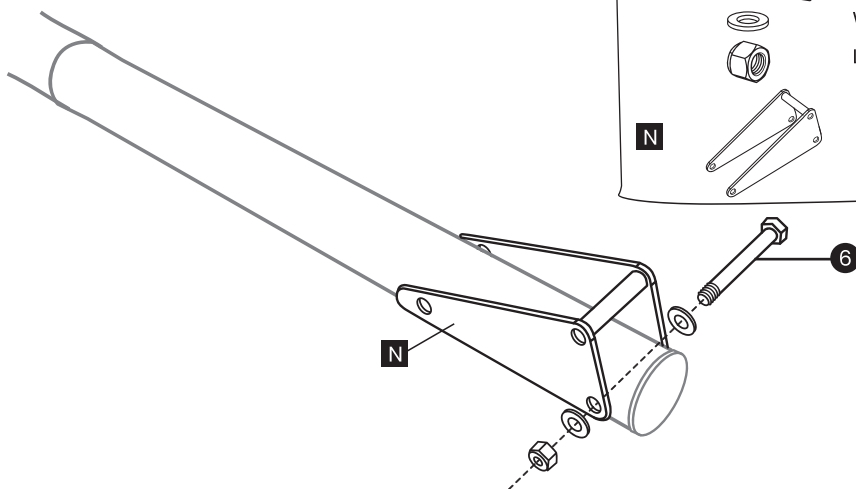
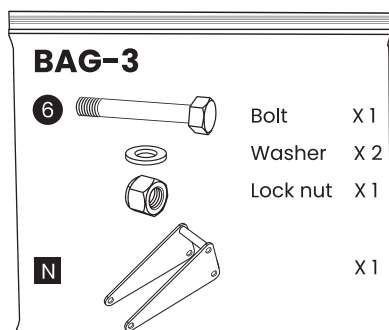
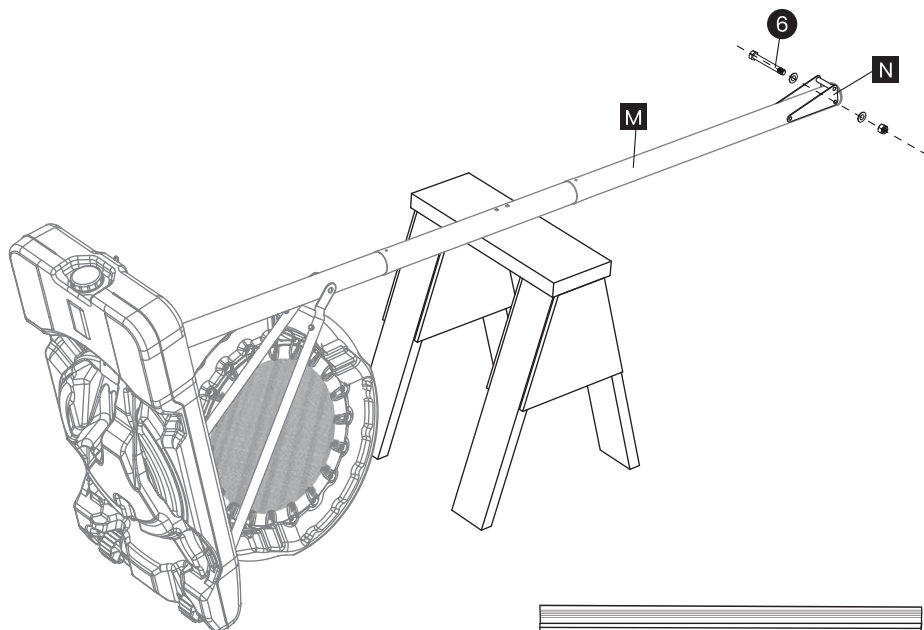

# STEP 7

Install the Upper Lifting Tube (K) to Top Pole (M) with one Screw set (9) and two Plastic Spacers (7) in **BAG-3**.

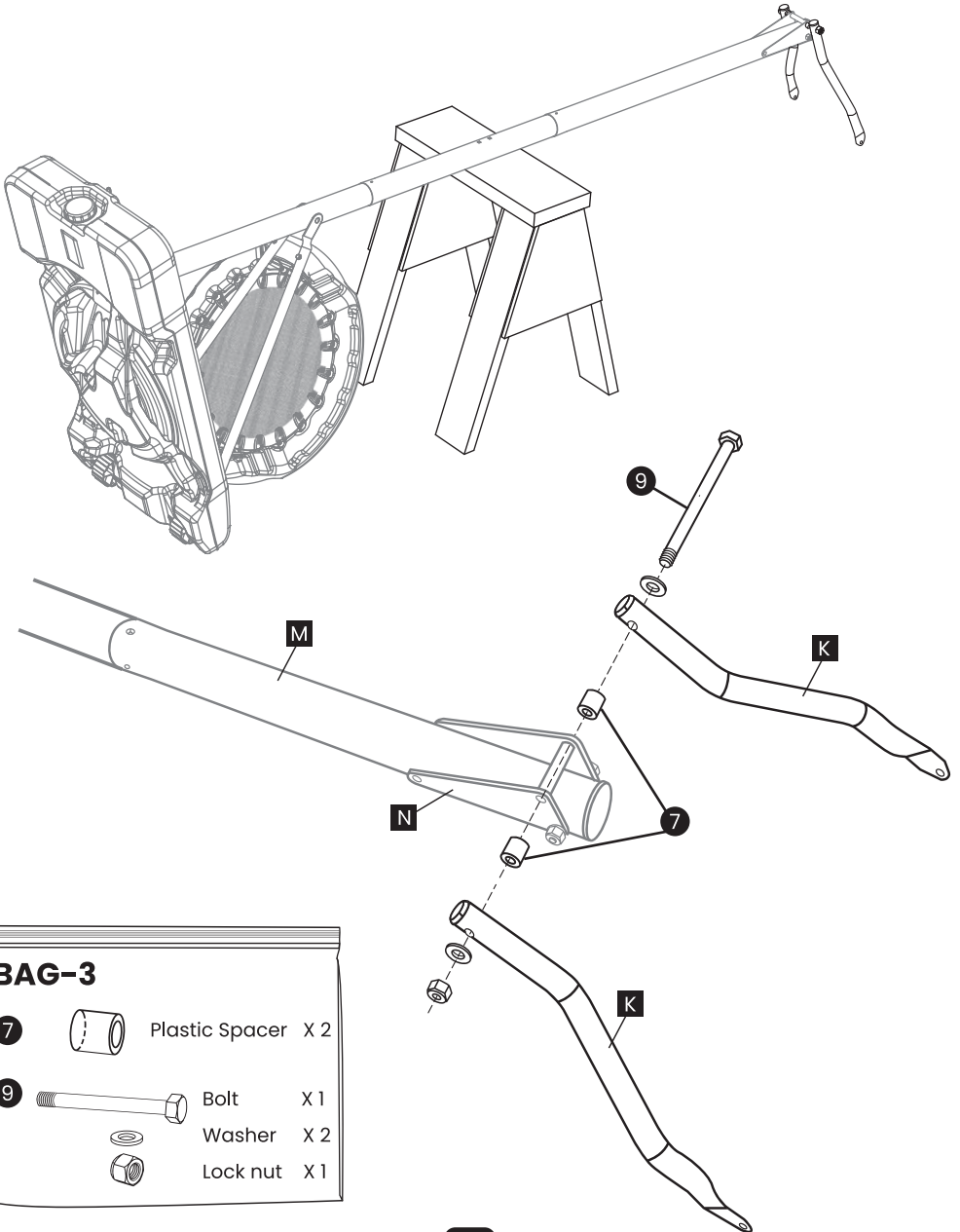

**BAG-3**

7		Plastic Spacer	X 2
9		Bolt	X 1
		Washer	X 2
		Lock nut	X 1

# STEP 8

Connect Lower Lifting Tube (J), Top Pole (M) and Triangle Connecting Plate (N) together with one Screw set (9) and two Plastic Spacers (7) in **BAG-3**.

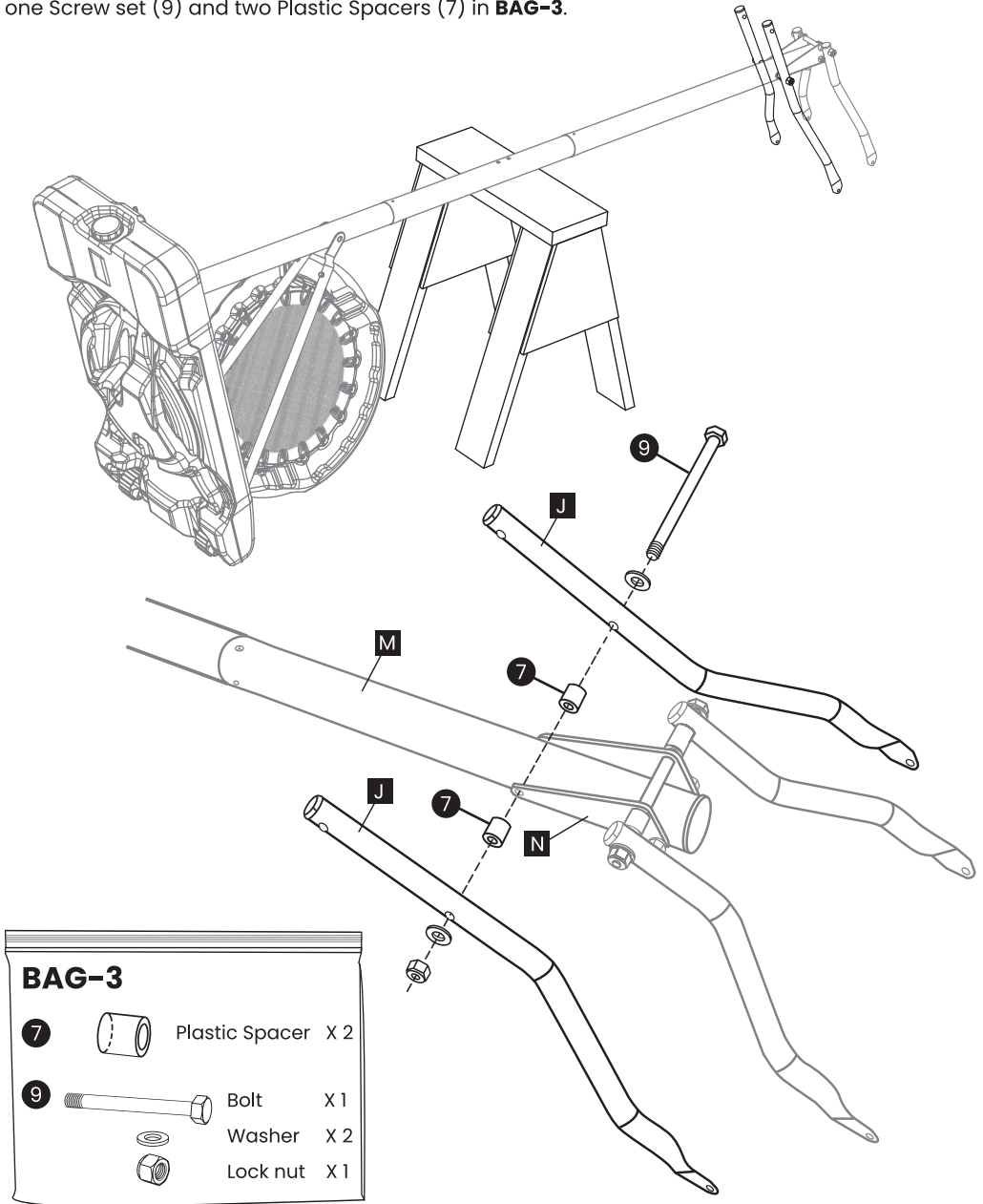

# STEP 9

Connect Backboard (L) to Lifting Tubes (J & K) with Screw set (10) in **BAG-4**.

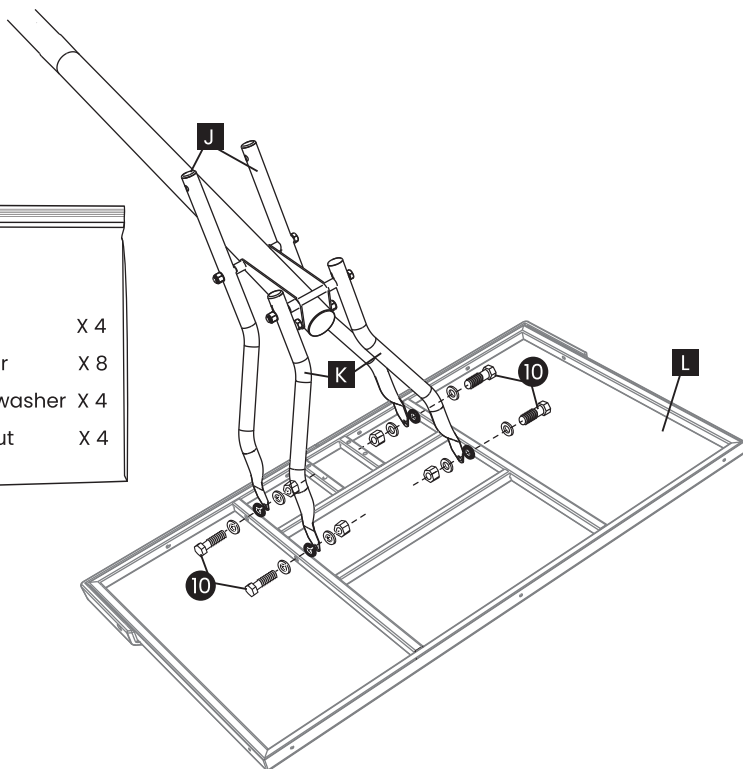
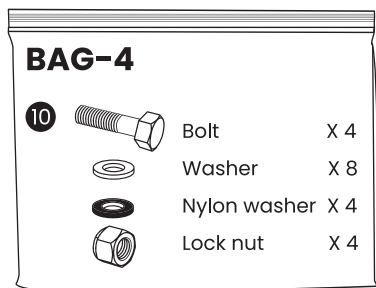
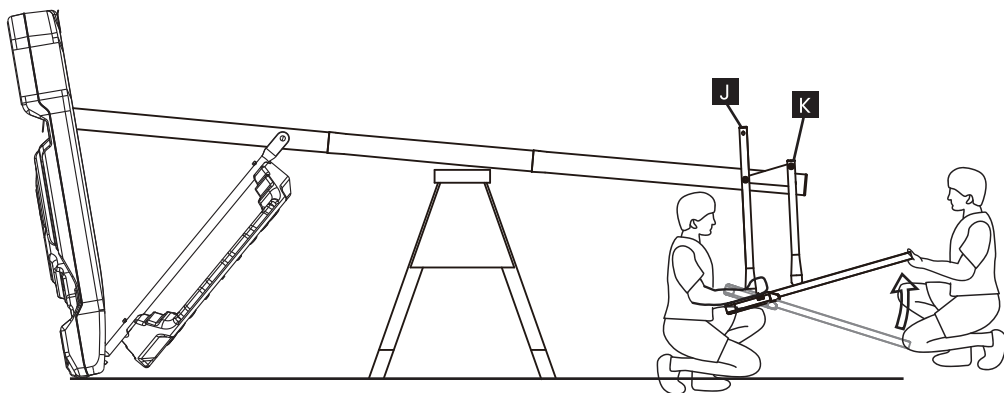







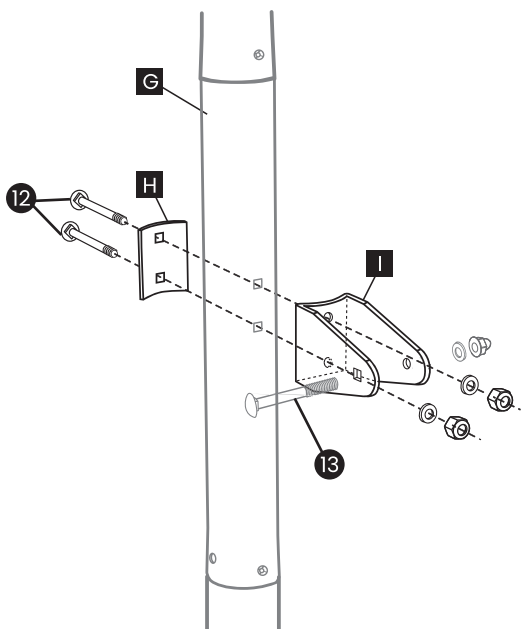
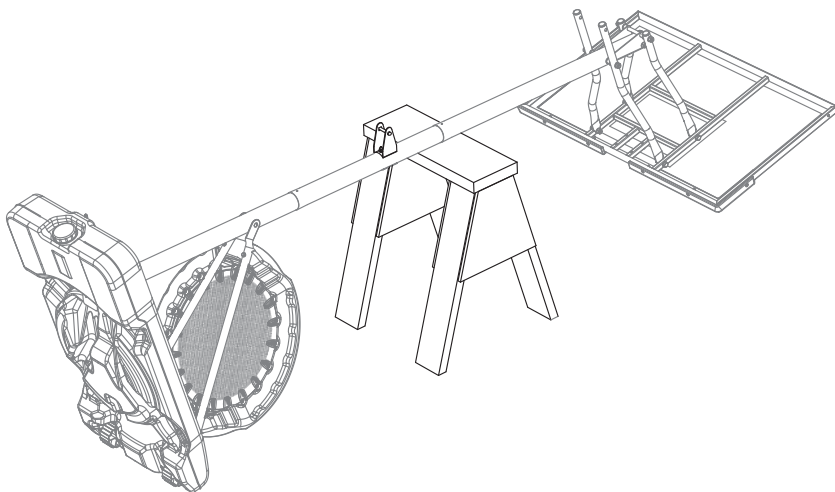

# STEP 10

Install Middle Pole Mounting Plate (H) and (I) to Middle Pole (G) with Screw set (12) in **BAG-5**.

**Attention:**

- Middle Pole Mounting Plate (I) should face the back of the basketball hoop.



<b>BAG-5</b>			
<b>12</b>		Bolt	X 2
		Lock nut	X 2
		Washer	X 2
<b>H</b>			X 1
<b>I</b>			X 1

# STEP 11

Install the upper part of the Height Adjustment Assembly (O) to the Lower Lifting Tube (J) with one Screw set (9) and two Plastic Spacers (8) in **BAG-3**.

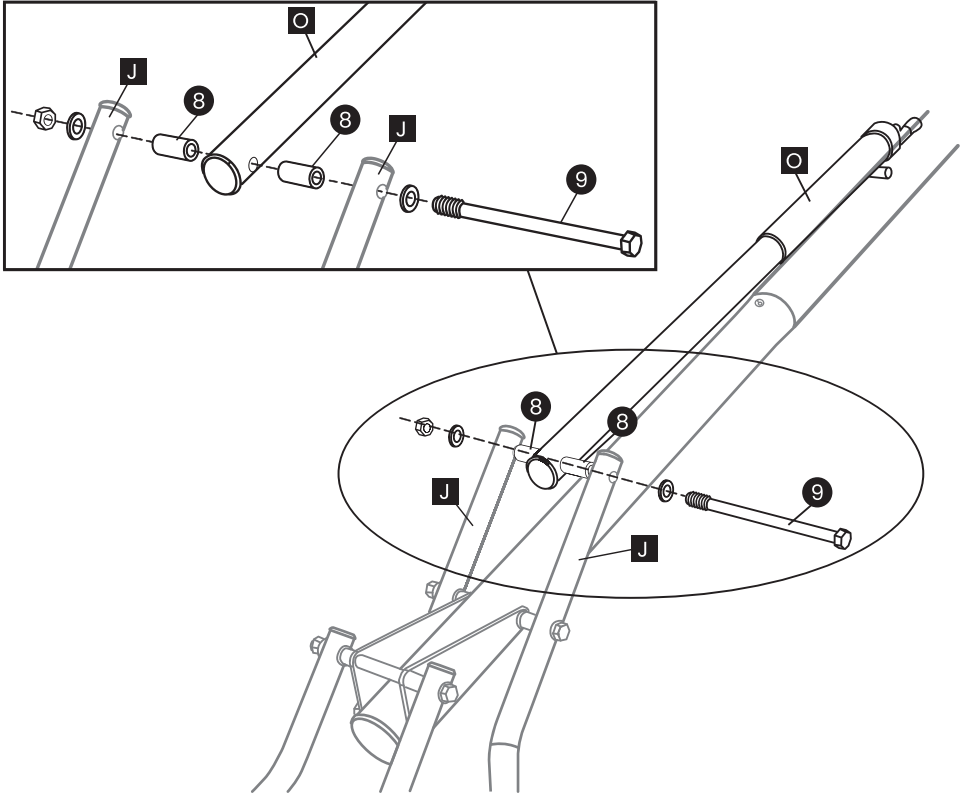

## COMPLETED ASSEMBLY

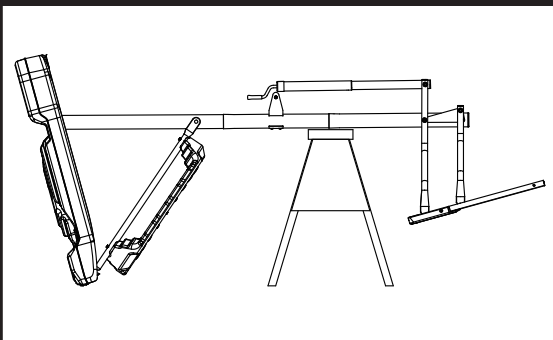

## BAG-3

- |  |                |     |
|--|----------------|-----|
|  | Plastic Spacer | X 2 |
|  | Bolt           | X 1 |
|  | Washer         | X 2 |
|  | Lock nut       | X 1 |

# STEP 12

Install the lower part of the Height Adjustment Assembly (O) to the Middle Pole Mounting Plate (I) with Screw set (13) in **BAG-5**.

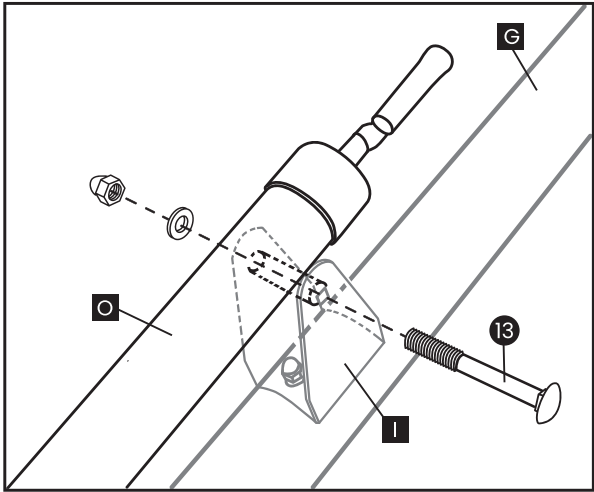

**BAG-3**

<b>13</b>		Bolt	X 1
		Washer	X 1
		Lock nut	X 1

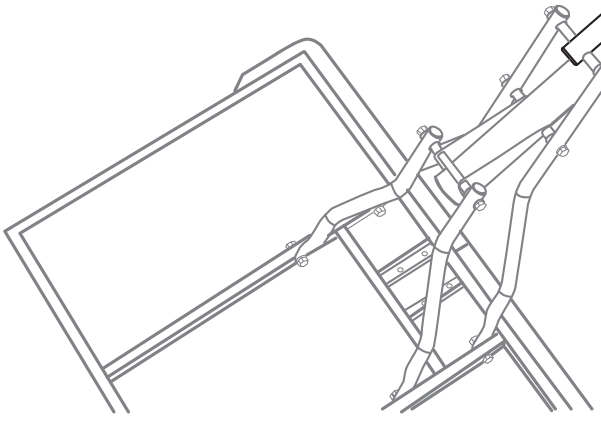
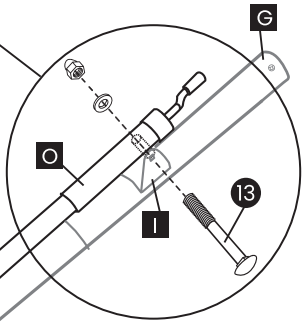

# STEP 13

Rotate the Crank Handle of the Height Adjustment Assembly (O) and adjust backboard (L) to 10ft height. Install the Rim (P) to the Backboard (L) with Screw set (II) in **BAG-4**. Install the Net (Q) to the Rim (P) as shown.

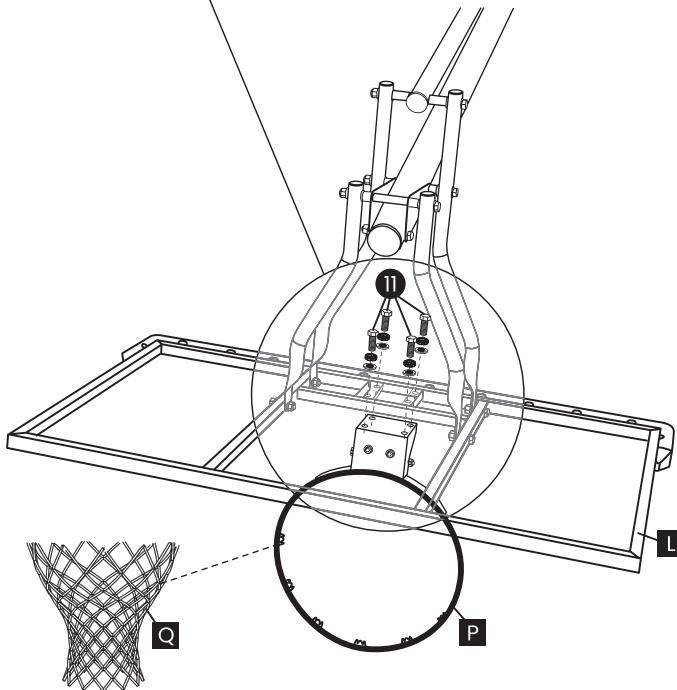
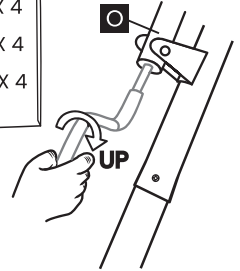
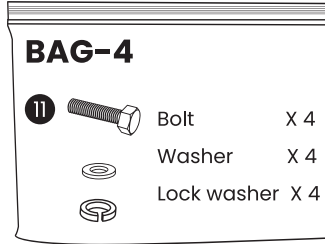
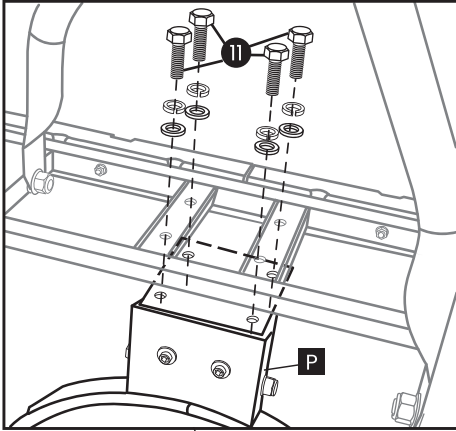

## NET AND RIM ASSEMBLY

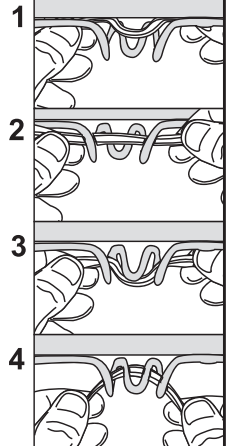

**PEEL PROTECTIVE FILM FROM SURFACE OF BACKBOARD**

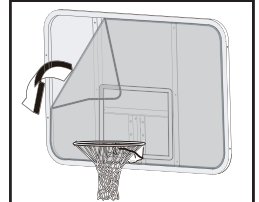

# STEP 14

Please follow the picture below for height adjustment.

**Note:**

- Turn the handle clockwise to lift up the backboard.
- Turn the handle counter-clockwise to lower down the backboard.

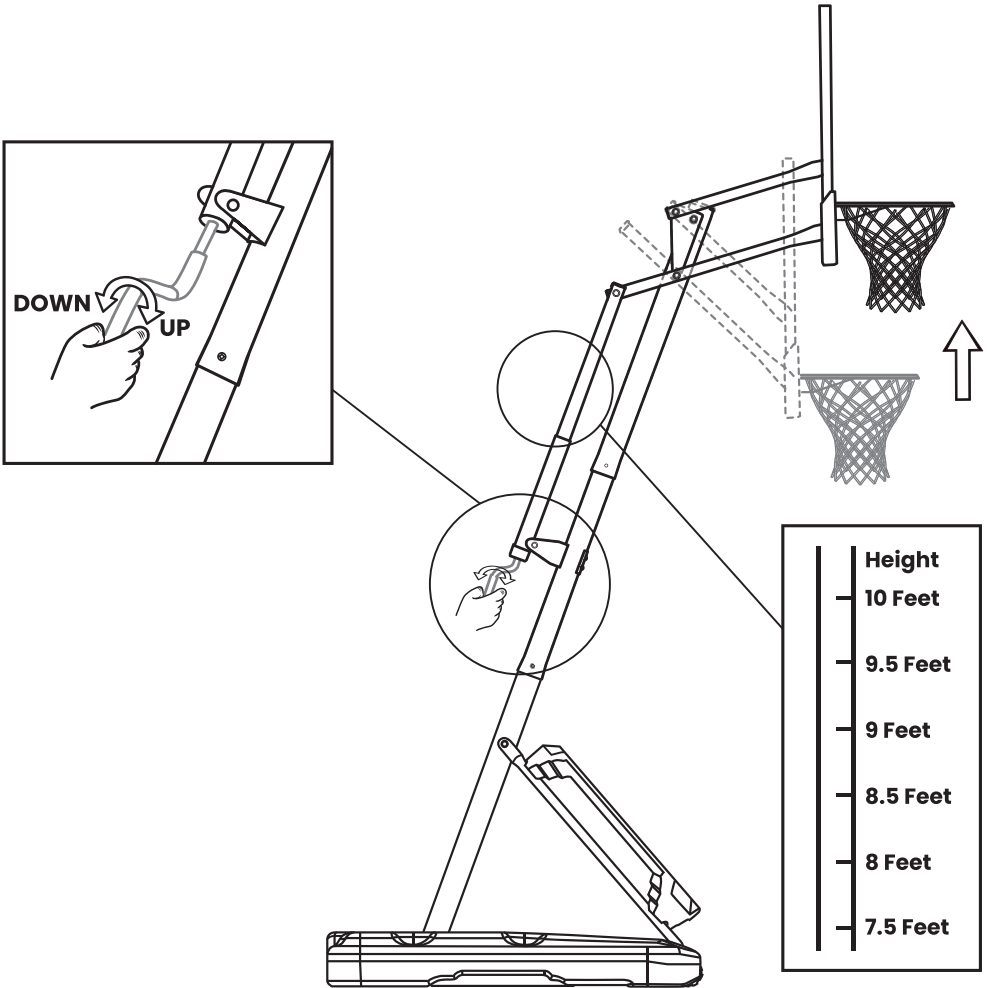

# STEP 15

## Moving and Filling the Basketball Hoop

To move the basketball hoop, two adults are required. Lower the backboard to the lowest height. Lift the back of the base up. When the wheels touch the ground, start moving the basketball hoop as shown below.

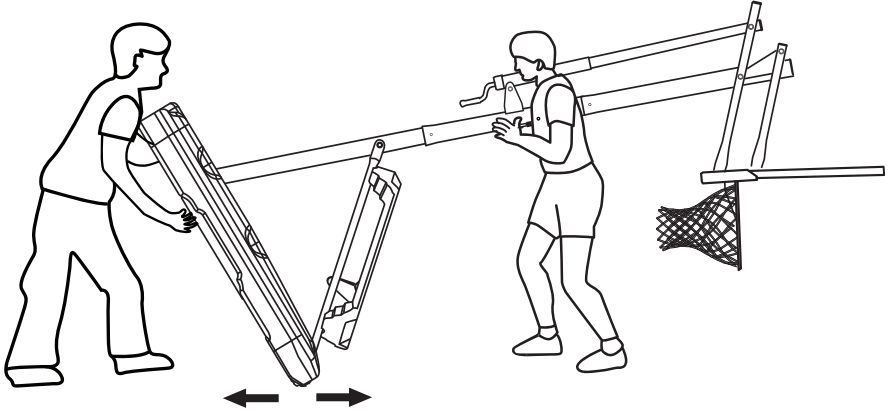

When the basketball hoop is moved to the intended place, place it on a sawhorse or work table carefully. To avoid damaging the Rim during filling, adjust backboard (L) to 10ft height or use a higher support table (above 35 inch). Then start filling the base with sand.

### WARNING:

- This Basketball Hoop requires **BOTH Dry Sand and Water** for filling. Failing to follow this instruction may result in serious injury and/or product damage.

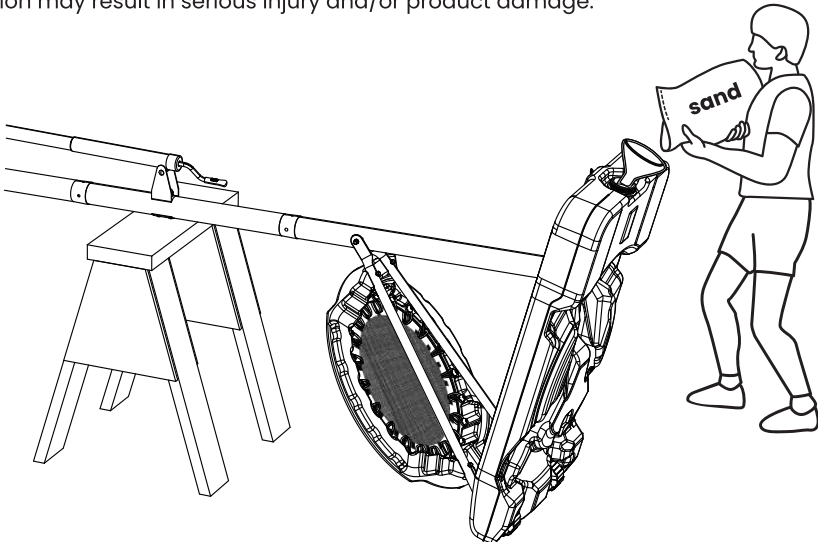

Start filling the base with dry sand first. To make the dry sand reached the bottom of the base easier, gently knock the left and right upper area of the base with a wooden hammer or rubber hammer. 177lb. / 80kg Dry Sand is required for filling.

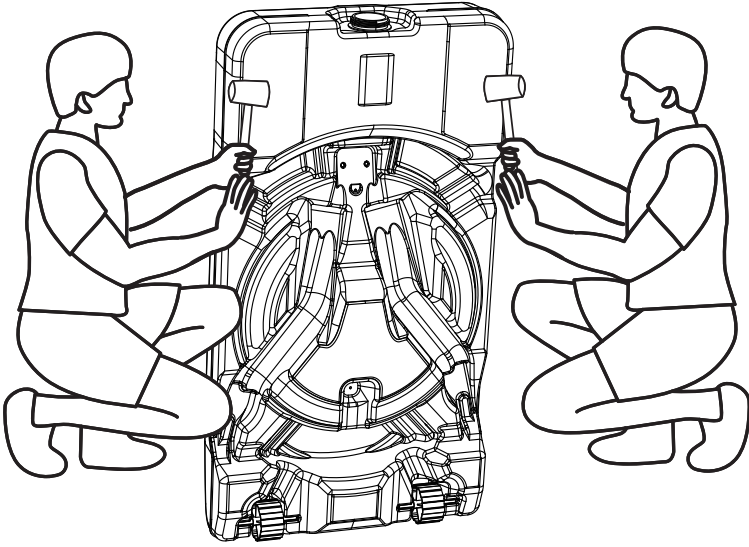

When finished filling the dry sand, start filling water into the base. 5.3gallon / 18kg Water is ALSO required for filling.

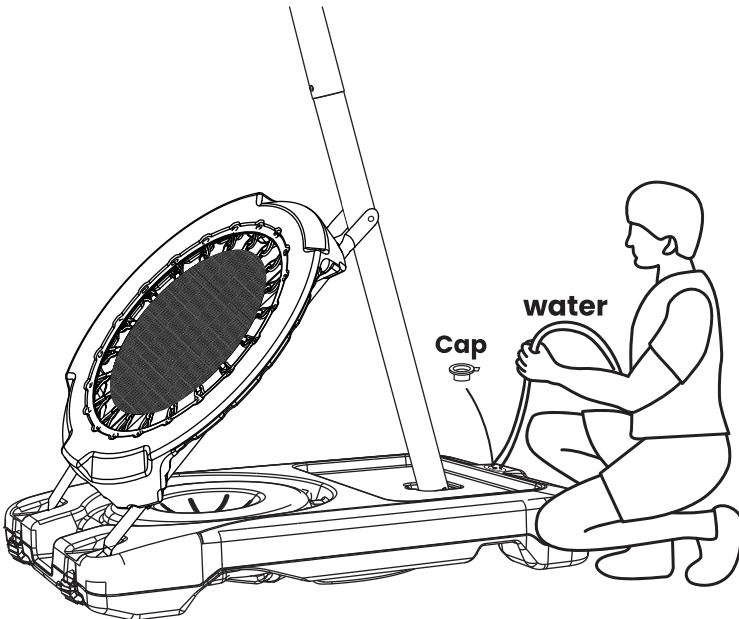

When finished filling both dry sand and water into the base, place the Basketball Hoop upright. Put another 2 bag of 55lb. /25kg sand bag on the base as shown. The basketball hoop is now ready to go.

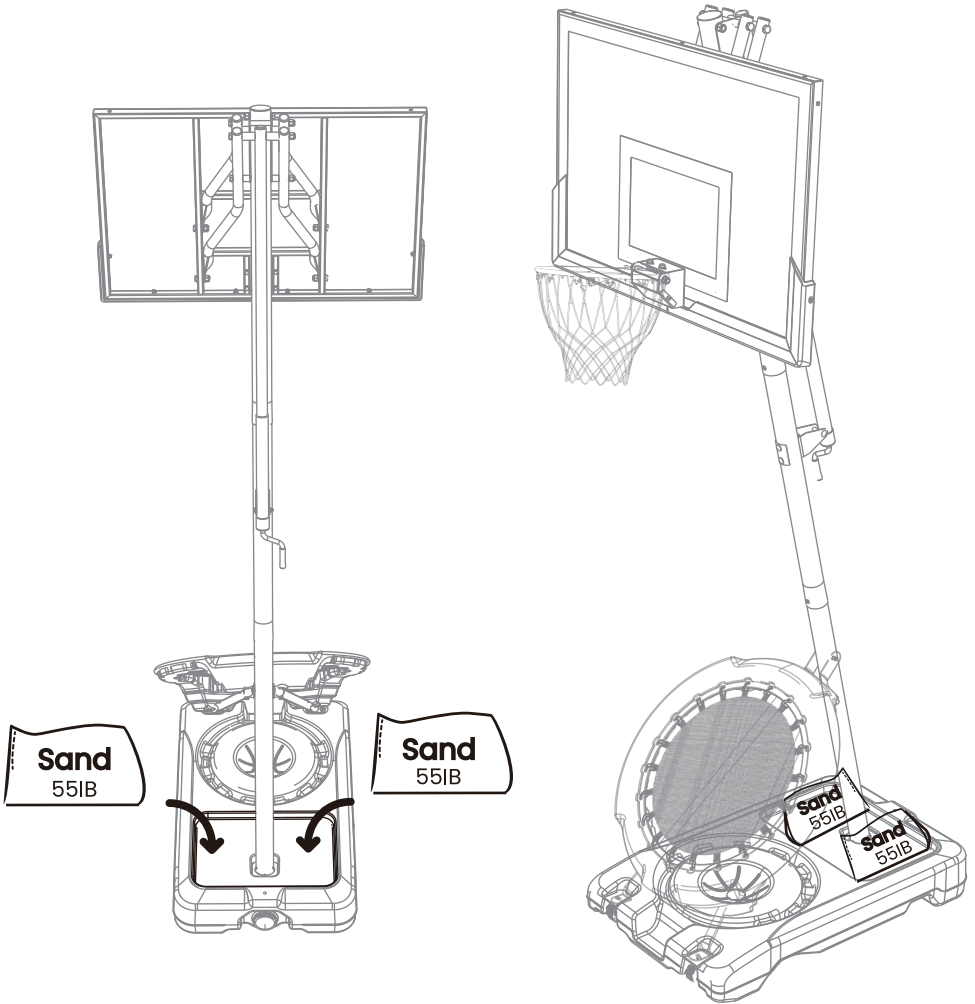

Save these instructions for future reference. For assistance:

**Customer Service Mailbox: [info@ie-sport.com](mailto:info@ie-sport.com)**  
**Customer Service Number: 909-966-9015**

Hours of Operation: Mon-Sat 10:00am - 4:00pm EDT (9:00am - 3:00pm EST)

**INNOVATIVE ENTERPRISE(US) 3647 De Forest Cir, Mira Loma, CA 91752**



**⚠ WARNING!**

**READ AND UNDERSTAND OPERATOR'S MANUAL BEFORE USING THIS UNIT.**

**FAILURE TO FOLLOW OPERATING INSTRUCTIONS COULD RESULT IN INJURY OR DAMAGE TO PROPERTY.**



When your Rebounder has no more bounce, please contact us, buy accessory to reassembly a bouncy rebounder.

**Customer Service Mailbox: [info@ie-sport.com](mailto:info@ie-sport.com)**  
**Customer Service Number: 909-966-9015**

Hours of Operation: Mon-Sat 10:00am - 4:00pm EDT (9:00am - 3:00pm EST)

INNOVATIVE ENTERPRISE(US) 3647 De Forest Cir, Mira Loma, CA 91752

**Rebounder Installation Illustration:**

**Please prepare the following accessories before installation:**

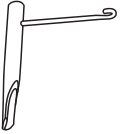

Hoop 1 pc



Elastic Cable Ties 20 pcs

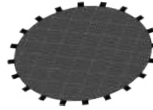

Mesh Fabric 1 pc

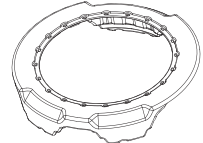

Rebounder Plate 1 pc

**Following the installation order as shown below will make the installation easier and more efficient.**

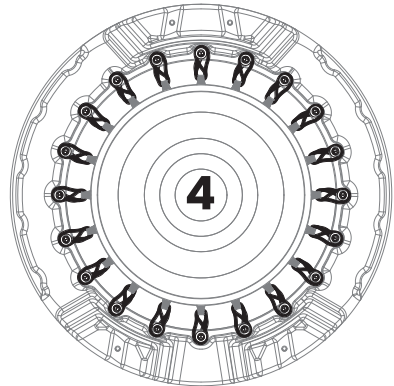
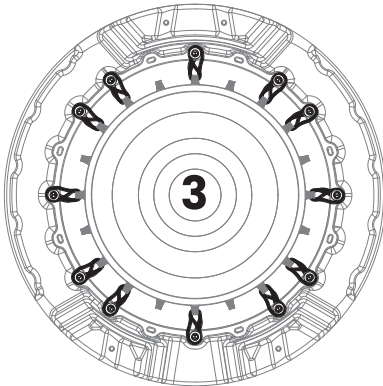
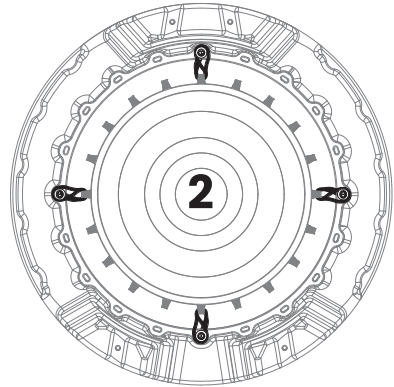
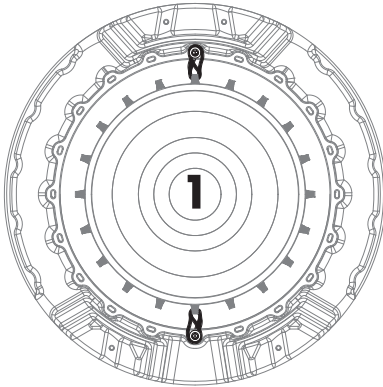

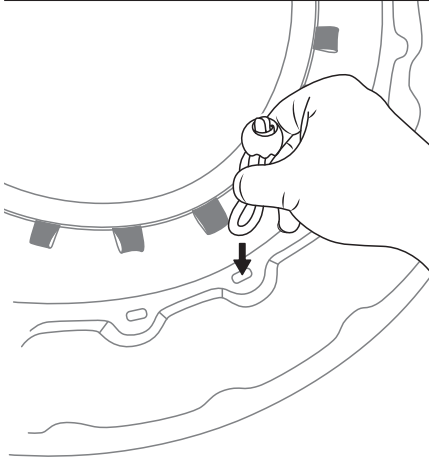
**1**

Place the rebounder with the back facing upwards.  
Thread the elastic cable tie into the hole of the rebounder.

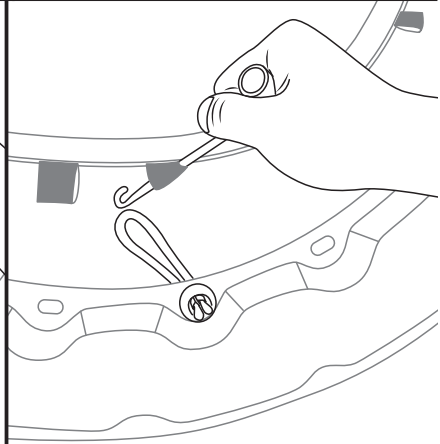
**2**

Use the hook and thread it through the mesh fabric loop.

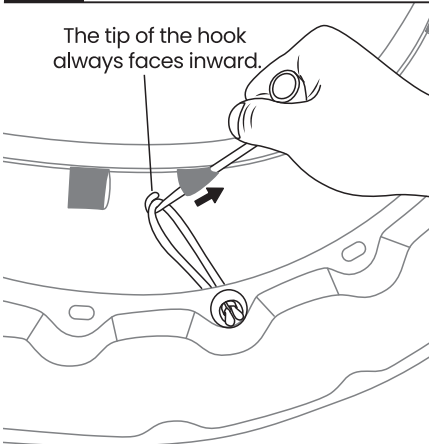
**3**

The tip of the hook always faces inward.

Use the hook and thread the elastic cable tie through the mesh fabric loop.  
Attention: When pulling the cable, keep the hook tip inward to prevent the hook from scratching the mesh fabric loop when passing through it.

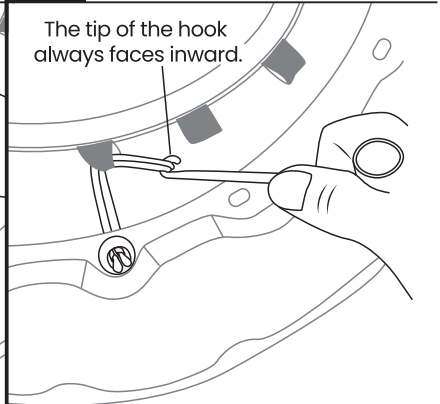
**4**

The tip of the hook always faces inward.

Hook the elastic cable tie and pull it through the mesh fabric loop.

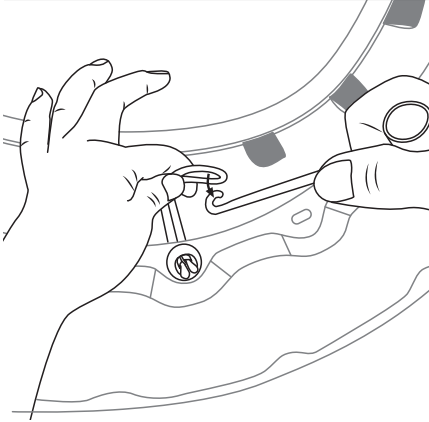
**5**

Grab the elastic cable tie that passes through the mesh fabric loop. Then, remove the hook from the elastic cable tie.

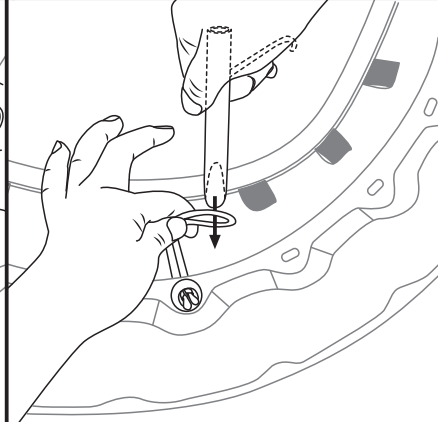
**6**

Follow the direction of the arrow, thread the hook handle through the plastic ball on the elastic cable tie.

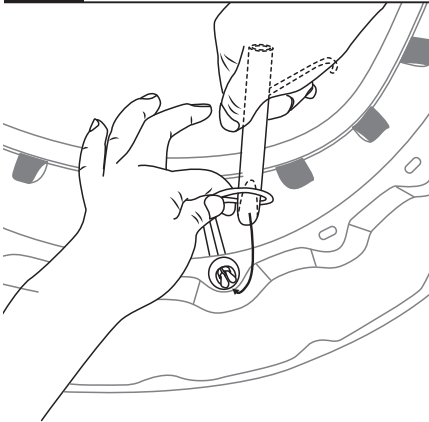
**7**

As shown by the arrow, use the hook handle to pull the elastic loop through the plastic ball at the top of the elastic cable tie.

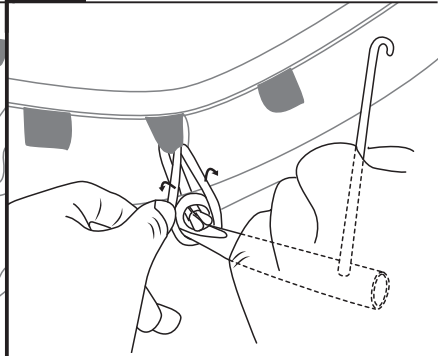
**8**

Pull the hook handle against the plastic ball, press the elastic cable tie downward. Let the elastic cable tie slide to the bottom of the plastic ball. Then, remove the hook handle. Repeat this step to complete the installation of the elastic cable ties