

TruePower[™]

MITER / CHOP SAW

01-0805

**ASSEMBLY AND OPERATING
INSTRUCTIONS**

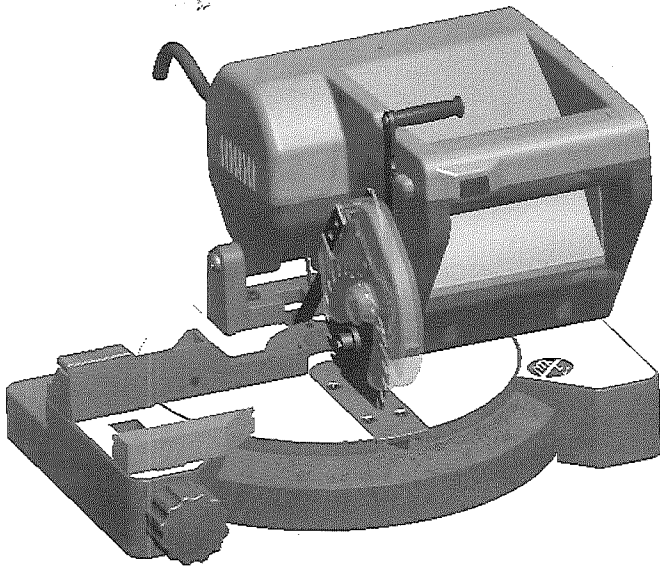

SAVE THIS MANUAL

Keep this manual for the safety warnings and precautions, assembly, operating, inspection, maintenance and cleaning procedures. Write the product's serial number in the back of the manual near the assembly diagram (or month and year of purchase if product has no number). Keep this manual and the receipt in a safe and dry place for future reference.

IMPORTANT SAFETY INFORMATION

In this manual, on the labeling, and all other information provided with this product:



This is the safety alert symbol. It is used to alert you to potential personal injury hazards. Obey all safety messages that follow this symbol to avoid possible injury or death.

DANGER

DANGER indicates a hazardous situation which, if not avoided, will result in death or serious injury.

WARNING

WARNING indicates a hazardous situation which, if not avoided, could result in death or serious injury.

CAUTION

CAUTION, used with the safety alert symbol, indicates a hazardous situation which, if not avoided, could result in minor or moderate injury.

NOTICE

NOTICE is used to address practices not related to personal injury.

CAUTION

CAUTION, without the safety alert symbol, is used to address practices not related to personal injury.

General Tool Safety Warnings



WARNING Read all safety warnings and instructions. *Failure to follow the warnings and instructions may result in electric shock, fire and/or serious injury. Save all warnings and instructions for future reference. The term "power tool" in the warnings refers to your mains-operated (corded) power tool.*

1. Work area safety
 - a. Keep work area clean and well lit. *Cluttered or dark areas invite accidents.*
 - b. Do not operate power tools in explosive atmospheres, such as in the presence of flammable liquids, gases or dust. *Power tools create sparks which may ignite the dust or fumes.*
 - c. Keep children and bystanders away while operating a power tool. *Distractions can cause you to lose control.*
2. Electrical safety
 - a. Power tool plugs must match the outlet. Never modify the plug in any way. Do not use any adapter plugs with grounded power tools. *Unmodified plugs and matching outlets will reduce risk of electric shock.*

- b. **Avoid body contact with grounded surfaces such as pipes, radiators, ranges and refrigerators.** *There is an increased risk of electric shock if your body is grounded.*
 - c. **Do not expose power tools to rain or wet conditions.** *Water entering a power tool will increase the risk of electric shock.*
 - d. **Do not abuse the cord.** *Never use the cord for carrying, pulling or unplugging the power tool. Keep cord away from heat, oil, sharp edges or moving parts. Damaged or entangled cords increase the risk of electric shock.*
 - e. **When operating a power tool outdoors, use an extension cord suitable for outdoor use.** *Use of a cord suitable for outdoor use reduces the risk of electric shock.*
 - f. **If operating a power tool in a damp location is unavoidable, use a Ground Fault Circuit Interrupter (GFCI) protected supply.** *Use of a GFCI reduces the risk of electric shock.*
3. **Personal safety**
- a. **Stay alert, watch what you are doing and use common sense when operating a power tool.** *Do not use a power tool while you are tired or under the influence of drugs, alcohol or medication. A moment of inattention while operating power tools may result in serious personal injury.*
 - b. **Use safety equipment. Always wear eye protection.** *Safety equipment such as dust mask, non-skid safety shoes, hard hat, or hearing protection used for appropriate conditions will reduce personal injuries.*
 - c. **Prevent unintentional starting.** *Ensure the switch is in the off-position before connecting to power source and/or battery pack, picking up or carrying the tool. Carrying power tools with your finger on the switch or energizing power tools that have the switch on invites accidents.*
 - d. **Remove any adjusting key or wrench before turning the power tool on.** *A wrench or a key left attached to a rotating part of the power tool may result in personal injury.*
 - e. **Do not overreach.** *Keep proper footing and balance at all times. This enables better control of the power tool in unexpected situations.*
 - f. **Dress properly.** *Do not wear loose clothing or jewelry. Keep your hair, clothing and gloves away from moving parts. Loose clothes, jewelry or long hair can be caught in moving parts.*
 - g. **If devices are provided for the connection of dust extraction and collection facilities, ensure these are connected and properly used.** *Use of these devices can reduce dust-related hazards.*
 - h. **Only use safety equipment that has been approved by an appropriate standards agency.** *Unapproved safety equipment may not provide adequate protection. Eye protection must be ANSI-approved and breathing protection must be NIOSH-approved for the specific hazards in the work area.*

4. **Power tool use and care**

- a. **Do not force the power tool. Use the correct power tool for your application.** *The correct power tool will do the job better and safer at the rate for which it was designed.*
- b. **Do not use the power tool if the switch does not turn it on and off.** *Any power tool that cannot be controlled with the switch is dangerous and must be repaired.*
- c. **Disconnect the plug from the power source and/or the battery pack from the power tool before making any adjustments, changing accessories, or storing power tools.** *Such preventive safety measures reduce the risk of starting the power tool accidentally.*
- d. **Store idle power tools out of the reach of children and do not allow persons unfamiliar with the power tool or these instructions to operate the power tool.** *Power tools are dangerous in the hands of untrained users.*
- e. **Maintain power tools. Check for misalignment or binding of moving parts, breakage of parts and any other condition that may affect the power tool's operation.** *If damaged, have the power tool repaired before use. Many accidents are caused by poorly maintained power tools.*
- f. **Keep cutting tools sharp and clean.** *Properly maintained cutting tools with sharp cutting edges are less likely to bind and are easier to control.*
- g. **Use the power tool, accessories and blades etc. in accordance with these instructions, taking**

into account the working conditions and the work to be performed. *Use of the power tool for operations different from those intended could result in a hazardous situation.*

5. **Service**

- a. **Have your power tool serviced by a qualified repair person using only identical replacement parts.** *This will ensure that the safety of the power tool is maintained.*

Miter Saw Safety Warnings

For Your Own Safety Read Instruction Manual Before Operating Miter Saw

1. Wear eye protection.
2. Keep hands out of path of saw blade.
3. Do not operate saw without guards in place.
4. Do not perform any operation free-hand.
5. Never reach around saw blade.
6. Turn off tool and wait for saw blade to stop before moving workpiece or changing settings.
7. Disconnect power before changing blade or servicing.
8. Return Handle to Locked position after each crosscut operation.
9. Return all guards to original position if any are moved during blade replacement. Check all guards for proper operation after service.
10. The use of accessories or attachments not recommended by the

manufacturer may result in a risk of injury to persons.

11. When servicing use only identical replacement parts.
12. Only use safety equipment that has been approved by an appropriate standards agency. Unapproved safety equipment may not provide adequate protection. Eye protection must be ANSI-approved and breathing protection must be NIOSH-approved for the specific hazards in the work area.
13. Maintain labels and nameplates on the tool. These carry important safety information. If unreadable or missing, contact Harbor Freight Tools for a replacement.
14. Avoid unintentional starting. Prepare to begin work before turning on the tool.
15. People with pacemakers should consult their physician(s) before use. Electromagnetic fields in close proximity to heart pacemaker could cause pacemaker interference or pacemaker failure. In addition, people with pacemakers should:
 - Avoid operating alone.
 - Do not use with power switch locked on.
 - Properly maintain and inspect to avoid electrical shock.
 - Any power cord must be properly grounded. Ground Fault Circuit Interrupter (GFCI) should also be implemented – it prevents sustained electrical shock.
16. Some dust created by power sanding, sawing, grinding, drilling, and other construction activities, contains

chemicals known [to the State of California] to cause cancer, birth defects or other reproductive harm. Some examples of these chemicals are:

- Lead from lead-based paints
- Crystalline silica from bricks and cement or other masonry products
- Arsenic and chromium from chemically treated lumber

Your risk from these exposures varies, depending on how often you do this type of work. To reduce your exposure to these chemicals: work in a well ventilated area, and work with approved safety equipment, such as those dust masks that are specially designed to filter out microscopic particles. (California Health & Safety Code § 25249.5, *et seq.*)

17. **WARNING:** Handling the cord on this product will expose you to lead, a chemical known to the State of California to cause cancer, and birth defects or other reproductive harm. Wash hands after handling. (California Health & Safety Code § 25249.5, *et seq.*)
18. The warnings, precautions, and instructions discussed in this instruction manual cannot cover all possible conditions and situations that may occur. It must be understood by the operator that common sense and caution are factors which cannot be built into this product, but must be supplied by the operator.



**SAVE THESE
INSTRUCTIONS.**

GROUNDING

⚠WARNING TO PREVENT ELECTRIC SHOCK AND DEATH FROM INCORRECT GROUNDING WIRE CONNECTION:



Check with a qualified electrician if you are in doubt as to whether the outlet is properly grounded. Do not modify the power cord plug provided with the tool. Never remove the grounding prong from the plug. Do not use the tool if the power cord or plug is damaged. If damaged, have it repaired by a service facility before use. If the plug will not fit the outlet, have a proper outlet installed by a qualified electrician.

Grounded Tools: Tools with Three Prong Plugs

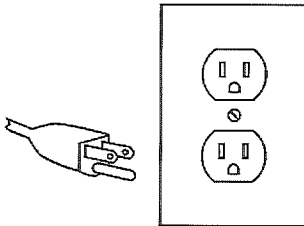

3-Prong Plug and Outlet

1. Tools marked with "Grounding Required" have a three wire cord and three prong grounding plug. The plug must be connected to a properly grounded outlet. If the tool should electrically malfunction or break down, grounding provides a low resistance path to carry electricity away from the user, reducing the risk

of electric shock. (See 3-Prong Plug and Outlet.)

2. The grounding prong in the plug is connected through the green wire inside the cord to the grounding system in the tool. The green wire in the cord must be the only wire connected to the tool's grounding system and must never be attached to an electrically "live" terminal. (See 3-Prong Plug and Outlet.)
3. The tool must be plugged into an appropriate outlet, properly installed and grounded in accordance with all codes and ordinances. The plug and outlet should look like those in the preceding illustration. (See 3-Prong Plug and Outlet.)

Double Insulated Tools: Tools with Two Prong Plugs

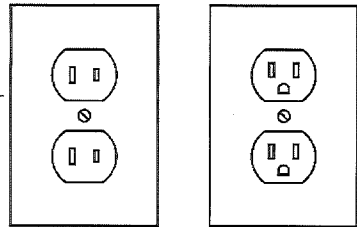

Outlets for 2-Prong Plug

1. Tools marked "Double Insulated" do not require grounding. They have a special double insulation system which satisfies OSHA requirements and complies with the applicable standards of Underwriters Laboratories, Inc., the Canadian Standard Association, and the National Electrical Code. (See Outlets for 2-Prong Plug.)

2. Double insulated tools may be used in either of the 120 volt outlets shown in the preceding illustration. (See **Outlets for 2-Prong Plug.**)

Extension Cords

1. **Grounded** tools require a three wire extension cord. **Double Insulated** tools can use either a two or three wire extension cord.
2. As the distance from the supply outlet increases, you must use a heavier gauge extension cord. Using extension cords with inadequately sized wire causes a serious drop in voltage, resulting in loss of power and possible tool damage. (See **Table A.**)
3. The smaller the gauge number of the wire, the greater the capacity of the cord. For example, a 14 gauge cord can carry a higher current than a 16 gauge cord. (See **Table A.**)
4. When using more than one extension cord to make up the total length, make sure each cord contains at least the minimum wire size required. (See **Table A.**)
5. If you are using one extension cord for more than one tool, add the nameplate amperes and use the sum to determine the required minimum cord size. (See **Table A.**)
6. If you are using an extension cord outdoors, make sure it is marked with the suffix "W-A" ("W" in Canada) to indicate it is acceptable for outdoor use.
7. Make sure the extension cord is properly wired and in good electrical con-







dition. Always replace a damaged extension cord or have it repaired by a qualified electrician before using it.

8. Protect the extension cords from sharp objects, excessive heat, and damp or wet areas.

| RECOMMENDED MINIMUM WIRE GAUGE FOR EXTENSION CORDS* (120/240 VOLT) | | | | | |
|--|-----------------------|-----|-----|------|------|
| NAMEPLATE AMPERES (at full load) | EXTENSION CORD LENGTH | | | | |
| | 25' | 50' | 75' | 100' | 150' |
| 0 - 2.0 | 18 | 18 | 18 | 18 | 16 |
| 2.1 - 3.4 | 18 | 18 | 18 | 16 | 14 |
| 3.5 - 5.0 | 18 | 18 | 16 | 14 | 12 |
| 5.1 - 7.0 | 18 | 16 | 14 | 12 | 12 |
| 7.1 - 12.0 | 18 | 14 | 12 | 10 | - |
| 12.1 - 16.0 | 14 | 12 | 10 | - | - |
| 16.1 - 20.0 | 12 | 10 | - | - | - |

TABLE A * Based on limiting the line voltage drop to five volts at 150% of the rated amperes.

Symbology

| | |
|---|--------------------------------------|
|  | Double Insulated |
|  | Canadian Standards Association |
|  | Underwriters Laboratories, Inc. |
|  | Volts Alternating Current |
|  | Amperes |
|  | No Load Revolutions per Minute (RPM) |

SPECIFICATIONS

| | |
|------------------|---|
| Motor | 120 V~ / 60 Hz / 2.5 A |
| Motor Speed | 9000 RPM |
| Blade | 3-1/8" Dia, 3/8" Arbor, 36 teeth, for wood |
| Cutting Capacity | At 90°: 1" x 1-15/16" At 45°: 1" x 1-1/4" |
| Table Stops | 0°, 15°, 22.5°, 30° and 45° both Right and Left |

UNPACKING

When unpacking, check to make sure that the item is intact and undamaged. If any parts are missing or broken, please call Anaconda Tools at 1-805-579-9292 as soon as possible.

List of contents

| Description | Qty |
|-----------------------------|-----|
| Miter/Chop Saw | 1 |
| 3-1/8" Carbide Tipped Blade | 1 |
| Spanner | 1 |
| Hex Wrench | 1 |

INITIAL SET UP INSTRUCTIONS



Read the **ENTIRE IMPORTANT SAFETY INFORMATION** section at the beginning of this manual including all text under subheadings therein before set up or use of this product.

▲WARNING TO PREVENT SERIOUS INJURY FROM ACCIDENTAL OPERATION: Turn the Power Switch of the tool to its "OFF" position and unplug the tool from its electrical outlet before assembling or making any adjustments to the tool.

Note: For additional information regarding the parts listed in the following pages, refer to the Assembly Diagram near the end of this manual.

Place this tool on a level, flat, and non-slippery surface. The workbench or table should be strong enough to support the weight of the tool, work piece, and related attachments and tools.

Functions

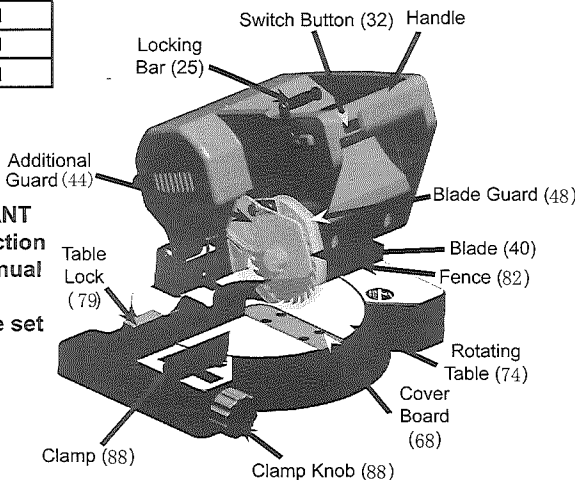

Figure 1

Replacing the Saw Blade

WARNING!

Always wear heavy duty work gloves when handling saw blades.

Note: Replacement Blade must be rated at 11000 RPM or greater.

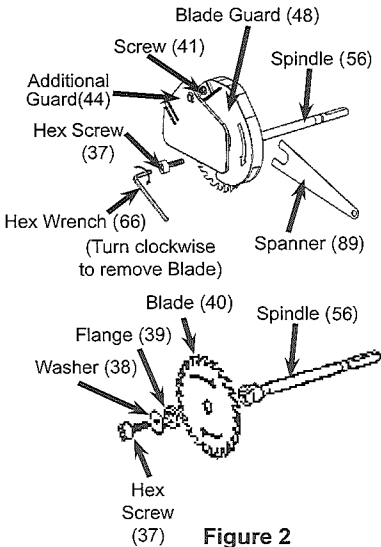

1. Unthread the top screw (41) on the Blade Guard (48) so that you can rotate the Blade Guard to access the Blade (40).
2. Lock the Spindle (56) with the Spanner (89).
3. Turn the Additional Guard (44) anticlockwise until it fastens the Blade Guard (48).
4. Using the Hex Wrench (66) unthread the Hex Screw (37), turning clockwise until the Hex Screw (37), Washer (38) and Flange (39) can be removed.

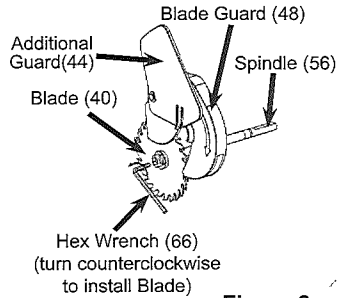

5. Carefully slide the Blade off of the Spindle.
6. Slide a new Blade onto the Spindle, making sure that the arrows on the Blade match the direction of the arrow on the Blade Guard.
7. Replace the Flange and Washer and rethread the Hex Screw back in place, turning counterclockwise, using the Spanner and Hex Wrench to tighten the screw in place.

Adjusting the Cutting Angle

The Table can be rotated so that you can make a cut from 0° to 45° in either direction starting from a perpendicular cut. To adjust the angle of the cut:

- a. Unlock the Rotating Table (74) by pulling up on the Table Lock (79).
- b. Rotate the Table to the desired angle, then re-lock it in place by pressing down firmly on the Table Lock.

Adjusting the Cutting Depth

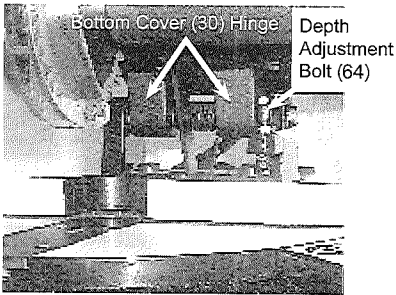

Figure 4

To adjust the maximum cutting depth, raise or lower the Depth Adjustment Bolt (64) located at the back of the tool, near the hinge by the Bottom Cover (30).

To make the adjustment:

1. Remove the four Screws (67) holding the Cover Board in place, and remove the Cover Board. (See Assembly Diagram 2 on page 17.)

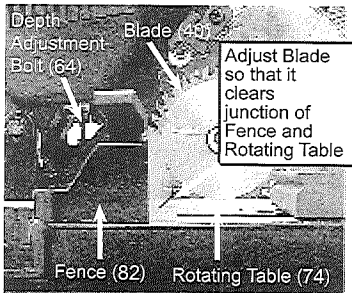

Figure 5

2. Using the Depth Adjustment Bolt, adjust the cutting depth so that the Blade (40) just clears the point where the Fence (82) and Rotating Table (74) meet.

To make this adjustment:

- a. Loosen the Nut (65), then turn the Depth Adjustment Bolt (64) counterclockwise to increase the cutting depth, or clockwise to decrease the cutting depth.
 - b. Tighten the Nut back down to hold the position of the Bolt.
3. Replace the Cover Board and four Screws.

CAUTION! Be careful not to set the cutting depth so low that the Blade will make contact with the Base (83).

CAUTION: Once the Cover Board (68) is cut, do not adjust the Depth Adjustment Bolt (64). If you set it lower than the initial Cover Board Cut, you risk cutting further into the Cover Board and/or cutting into the Base (83) of the tool and damaging the structure of the tool.

Initial Cover Board Cut

Before the first time the Saw is used, the kerf, or saw entry slot, needs to be cut into the Cover Board (68). Creating this opening by cutting it with the Saw ensures that the opening will be as narrow as possible so work material won't be in danger of being dragged into the opening. It also ensures that the opening will be perfectly in-line with the Blade.

1. To make the opening:
 - a. Set the rotating table to 0°.
 - b. Follow all safety practices for Work area set up.
 - c. Plug the power cord into the nearest outlet.

- d. Grip the Handle, squeeze the Locking Bar Handle (26) and pull down on the Handle just enough to release the catch of the Locking Bar Handle.
- e. Press and hold the Switch Button (32) to start the Blade turning.

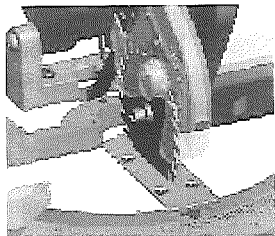

- f. Once the Blade has come up to full speed, use light downward pressure to cut a slot in the Cover Board. If the material binds the blade, release the Switch Button. Keep your hands away from the Blade.
- g. When the cut is completed, release the Switch Button and raise the Handle.
- h. Wait for the Blade to stop turning, then blow away debris from the cut.
- i. If needed, file or sand off any burrs left in the cut.

OPERATING INSTRUCTIONS



Read the **ENTIRE IMPORTANT SAFETY INFORMATION** section at the beginning of this manual including all text under subheadings therein before set up or use of this product.

⚠ WARNING TO PREVENT SERIOUS INJURY FROM ACCIDENTAL OPERATION:
Unplug power cord from power source before making any adjustments to this tool.

Work Piece and Work Area Set Up

1. Designate a work area that is clean and well-lit. The work area must not allow access by children or pets to prevent distraction and injury.
2. Route the power cord along a safe route to reach the work area without creating a tripping hazard or exposing the power cord to possible damage. The power cord must reach the work area with enough extra length to allow free movement while working.
3. Work pieces must be secured to the saw table using the Clamp (87). Securing the work piece will provide safety by preventing kick back and by removing the need to hold work pieces near the blade by hand. Clamping the work piece will also improve cutting accuracy by preventing the work piece from shifting during the cutting process.
4. Allow room on both left and right of saw for work pieces which extend beyond the saw table.

General Operating Instructions

1. When the Handle is lowered, the Blade Guard raises automatically. When the Handle is raised the Blade Guard returns to its safety position. Keep hands clear of the Blade when the Handle is lowered. Never

interfere with the proper movement of the Blade Guard.

2. Before starting work, check the accuracy of the miter angle and the depth of the cut.
3. It is very important that the work material be properly supported before making a cut. The material must be level on the Table. The material must be supported at both ends and held in place with the Clamp (87).

Making a Cut

1. Observe all safety and planning instructions discussed in this booklet. Do not make any cuts until you have read this entire booklet and are familiar with the operation of this tool.
2. Grip the Handle, squeeze the Locking Bar Handle (26) and pull down on the Handle releasing the catch of the Locking Bar Handle. Lower the Handle to check that the saw will enter the opening in the Cover Board (68) and not any further. Raise the saw so the Locking Bar holds the Handle in place. Adjust the cutting depth if needed.
3. Check to be sure the Rotating Table (74) is locked in place at the desired miter angle.
4. Blow any sawdust or debris away from the Fence. Place the work material against the Fence.
5. Make any necessary miter adjustments.
6. Align the marked location of the cut on the work material with the Saw Blade (40). Be aware that the Saw Blade will remove material from the cut equal to the width of the blade. This is the "kerf". To prevent your work piece from being cut too short, align the edge of the blade with your measured mark, keeping the kerf on the waste side of the cut.
7. Turn the Clamp Knob (88) counterclockwise to slide the Clamp up to the work material until it is held firmly in place. Ensure that the work material is level and supported securely, using additional supports if necessary.
8. Grip the Handle, squeeze the Locking Bar Handle (26) and pull down on the Handle just enough to release the catch of the Locking Bar Handle.
9. Press and hold the Switch Button (32) to start the Blade turning.
10. Once the Blade has come up to full speed, press down lightly on the material, moving the Blade smoothly through the work material to cut it. Do not bear down on the material, use light downward pressure. If the material binds the blade, release the Switch Button. Keep your hands away from the Blade.
11. When the cut is completed, release the Switch Button and raise the Handle.
12. Wait for the Blade to stop turning, then remove the work material from the saw.

MAINTENANCE AND SERVICING



Procedures not specifically explained in this manual must be performed only by a qualified technician.

⚠WARNING TO PREVENT SERIOUS INJURY FROM ACCIDENTAL OPERATION:

Turn the Power Switch of the tool to its "OFF" position and unplug the tool from its electrical outlet before performing any inspection, maintenance, or cleaning procedures.

**TO PREVENT SERIOUS
INJURY FROM TOOL
FAILURE:** Do not use
damaged equipment. If
abnormal noise or vibration
occurs, have the problem
corrected before further use.

Cleaning, Maintenance, and Lubrication

- BEFORE EACH USE**, inspect the general condition of the tool. Check for loose screws, misalignment or binding of moving parts, cracked or broken parts, damaged electrical wiring, and any other condition that may affect its safe operation.
- AFTER USE**, clean the tool with compressed air, blowing off sawdust and debris. Wipe external surfaces with a clean cloth.
- If the blade has become dirty, use a blade cleaner (not included) to clean it. Dirty blades will bind more easily, and will more often overheat and burn the wood as it cuts. Overheated blades dull more easily.
- If the Blade has become dull, replace it. Dull blades will cause increased tear-out and ragged edges on the cuts.
- Occasionally clean the rotating Table components and other moving parts. Use a good quality dry lubricant (not included) which will not attract dust.
- After cleaning, store the tool indoors out of children's reach.
- ⚠WARNING!** If the supply cord of this power tool is damaged, it must be replaced only by a qualified service technician.

Troubleshooting

| Problem | Possible Causes | Likely Solutions |
|--|---|---|
| Saw will not start | <ol style="list-style-type: none"> 1. No power at outlet. 2. Cord not connected. 3. Defective On/Off Switch. | <ol style="list-style-type: none"> 1. Check power at outlet. 2. Check that cord is plugged in. 3. Have Switch replaced. |
| Saw operates sporadically or at low power | <ol style="list-style-type: none"> 1. Low power supply or improper extension cords. 2. Worn or cracked Carbon Brushes. | <ol style="list-style-type: none"> 1. Check power supply and power cords. 2. Have a qualified technician check Carbon Brushes and replace if damaged or worn. |
| Wood burns at ends when cut | <ol style="list-style-type: none"> 1. Dirty Blade. 2. Material is binding. | <ol style="list-style-type: none"> 1. Clean Blade using blade cleaner or mineral spirits. 2. Check position of work material on Table. Material must be flat, flush against Fence and supported on ends. |
| Material frays or chips out. | <ol style="list-style-type: none"> 1. Finished side is down. 2. Blade is chipped or dull. 3. Blade is inappropriate for material. 4. Material is unsupported. | <ol style="list-style-type: none"> 1. Always have finished side of material up or facing you. Bottom and back side are prone to chip out. 2. Check for damaged teeth. Sharpen or replace blade. 3. Check blade manufacturer's recommendations for material being cut. For cross cutting hard wood and for precision cuts use a thin kerf blade with 60 or more teeth. 4. Use a thin piece of sacrificial material, such as 1/4" plywood, underneath or behind the material to support the edges of the material as it is being cut. |
| Blade binds, slowing or stopping saw. | <ol style="list-style-type: none"> 1. Material is misaligned on the saw or ends are not supported. 2. Material is wet, contaminated or inappropriate blade is being used. | <ol style="list-style-type: none"> 1. Material must be flat on table, flush against the fence and supported on both ends. 2. Check condition of material and check compatibility of blade to material. |
|  <p>Follow all safety precautions whenever diagnosing or servicing the tool. Disconnect power supply before service.</p> | | |

PLEASE READ THE FOLLOWING CAREFULLY

THE MANUFACTURER AND/OR DISTRIBUTOR HAS PROVIDED THE PARTS LIST AND ASSEMBLY DIAGRAM IN THIS MANUAL AS A REFERENCE TOOL ONLY. NEITHER THE MANUFACTURER OR DISTRIBUTOR MAKES ANY REPRESENTATION OR WARRANTY OF ANY KIND TO THE BUYER THAT HE OR SHE IS QUALIFIED TO MAKE ANY REPAIRS TO THE PRODUCT, OR THAT HE OR SHE IS QUALIFIED TO REPLACE ANY PARTS OF THE PRODUCT. IN FACT, THE MANUFACTURER AND/OR DISTRIBUTOR EXPRESSLY STATES THAT ALL REPAIRS AND PARTS REPLACEMENTS SHOULD BE UNDERTAKEN BY CERTIFIED AND LICENSED TECHNICIANS, AND NOT BY THE BUYER. THE BUYER ASSUMES ALL RISK AND LIABILITY ARISING OUT OF HIS OR HER REPAIRS TO THE ORIGINAL PRODUCT OR REPLACEMENT PARTS THERETO, OR ARISING OUT OF HIS OR HER INSTALLATION OF REPLACEMENT PARTS THERETO.

PARTS LIST

| NO. | Description | QTY | NO. | Description | QTY |
|-----|-------------------------------------|-----|-----|---------------------------|-----|
| 1 | Upper cover | 1 | 46 | Undee gasket | 1 |
| 2 | Cable jacket | 1 | 47 | Guard set plate | 1 |
| 3 | Power cord | 1 | 48 | Blade guard | 1 |
| 4 | Screw M4x6 | 2 | 49 | Guard set pin | 1 |
| 5 | Spring washer $\Phi 4$ | 4 | 50 | Nylon locknut M6 | 1 |
| 6 | Flat washer $\Phi 4$ | 4 | 51 | Guard support subassembly | 1 |
| 7 | Motor cover | 1 | 52 | Guard support pin | 1 |
| 8 | Bearing 608 | 4 | 53 | Dentate gasket | 1 |
| 9 | Brush | 2 | 54 | Nylon locknut M6 | 1 |
| 10 | Brush holder | 1 | 55 | Bearing seating | 1 |
| 11 | Screw M3x6 | 4 | 56 | Spindle | 1 |
| 12 | Alumina | 1 | 57 | Retaining ring $\Phi 8$ | 4 |
| 13 | Motor housing | 1 | 58 | Synchronous belt | 1 |
| 14 | Fixed button | 4 | 59 | Lock pin | 1 |
| 15 | Self tap screw M4x16 | 3 | 60 | Torsion spring | 1 |
| 16 | Rotor | 1 | 61 | Flat washer $\Phi 8$ | 4 |
| 17 | Fan | 1 | 62 | Bracket | 1 |
| 18 | Screw M4x20 | 2 | 63 | Inner hex screw M6x20 | 2 |
| 19 | Synchronous pulley | 1 | 64 | hexagon headed bolt M5x38 | 1 |
| 20 | Hex locked screw M4x4 | 2 | 65 | Hexagon nut M5 | 1 |
| 21 | Motor base | 1 | 66 | Hex spanner 4mm | 1 |
| 22 | Flat washer $\Phi 5$ | 2 | 67 | Sunk screw M4x10 | 4 |
| 23 | Screw M5x8 | 2 | 68 | cover board | 1 |
| 24 | Sunk self tap screw M4x12 | 1 | 69 | Screw M5x8 | 1 |
| 25 | Locked bar | 1 | 70 | finger | 1 |
| 26 | Handle | 1 | 71 | Locked screw M7x8 | 1 |
| 27 | Locked bar spring | 1 | 72 | Spring | 1 |
| 28 | Self tap screw M4x14 | 3 | 73 | Steel ball $\Phi 6$ | 1 |
| 29 | Power cord clamp | 1 | 74 | Rotating table | 1 |
| 30 | Bottom cover | 1 | 75 | Guard holder pin | 1 |
| 31 | Switch | 1 | 76 | Hexagon nut M6 | 1 |
| 32 | Switch button | 1 | 77 | Spring washer $\Phi 5$ | 1 |
| 33 | Converter | 1 | 78 | Locked handle bush | 1 |
| 34 | Self tap screw M4x16 | 10 | 79 | Locked handle | 1 |
| 35 | Flat washer $\Phi 6$ | 8 | 80 | hexagon headed bolt M6x20 | 2 |
| 36 | Retaining ring $\Phi 4$ | 3 | 81 | Sunk screw M6x25 | 1 |
| 37 | Inner hex screw (L) M5x10 | 1 | 82 | Fence | 1 |
| 38 | Flat washer $\Phi 6.3g \Phi 16x1.5$ | 1 | 83 | Base | 1 |
| 39 | Blade flange | 1 | 84 | Rubber foot | 4 |
| 40 | Blade | 1 | 85 | Undee gasket | 1 |
| 41 | Screw M5x6 | 1 | 86 | Retaining ring $\Phi 16$ | 1 |
| 42 | Spring washer $\Phi 5$ | 1 | 87 | Object holder block | 1 |
| 43 | Retaining ring | 1 | 88 | Object holder belt | 1 |
| 44 | Additional guard | 1 | 89 | Spanner 12mm | 1 |
| 45 | Torsion spring | 1 | 90 | | |

ASSEMBLY DIAGRAMS

Assembly Diagram 1

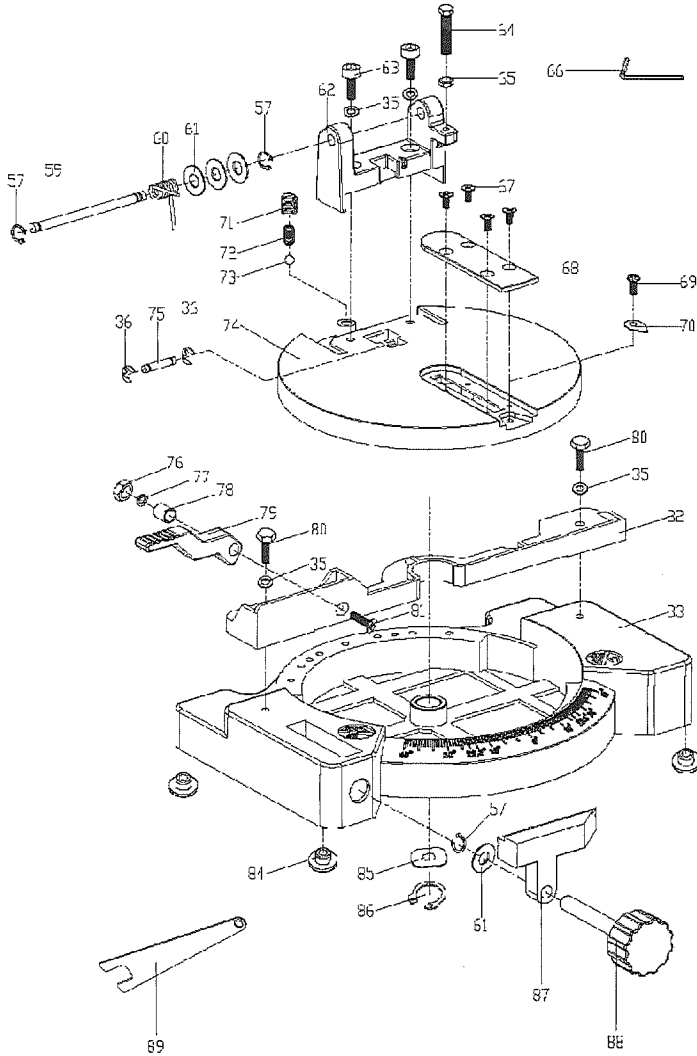

Assembly Diagram 2

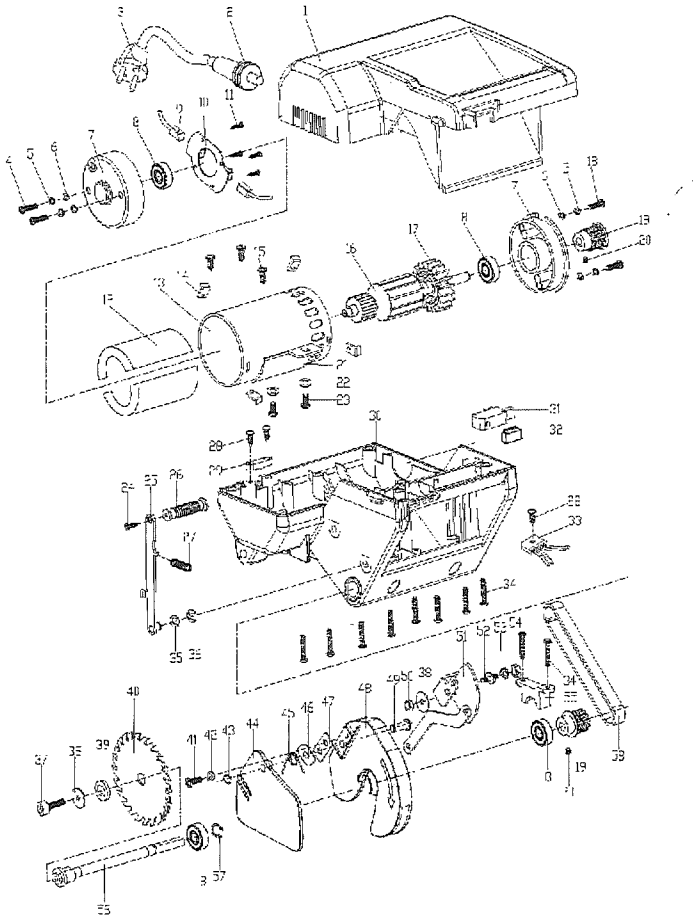

Record Product's Serial Number Here: _____

Note: If product has no serial number, record month and year of purchase instead.

Note: Some parts are listed and shown for illustration purposes only, and are not available individually as replacement parts.