



Ranein

RV TANKLESS WATER HEATER
Instruction For Installation And Use
Model:RA65L

www.raneinrv.com
service@raneinrv.com



Scan QR codeto
start a chat



Scan QR code
to follow accounta YouTube

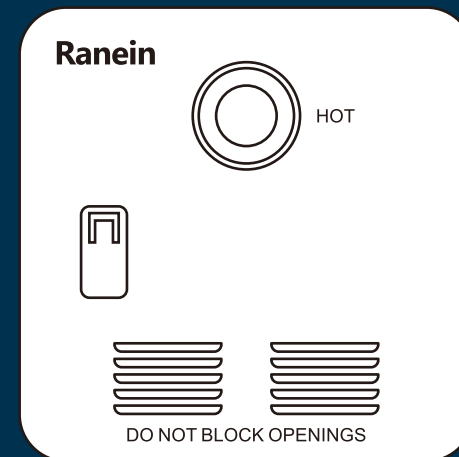

WARRANTY

Limited Warranty

Ranein provides a one-year warranty for customers who purchase on the Ranein Amazon store and the Ranein official website.

Warranty Period

The warranty starts from the date of purchase by the original purchaser. Please provide the screenshot of the order from Amazon or the website to affirm the warranty start date.

Tips

If there is any problem with the product, you can provide us with pictures and videos for confirmation. After the confirmation of the technicians, we will provide return and exchange services for you.

Customer support

service@raneinrv.com

www.raneinrv.com

⚠ WARNING

If the information in these instructions is not followed strictly, a fire or explosion may result, causing property damage, personal injury, or death.

– **Do not store or use gasoline or other flammable vapors and liquids near this or any other appliance.**

– WHAT TO DO IF YOU SMELL GAS

- Evacuate all persons from the vehicle.
- Shut off the gas supply at the gas container or source.
- **DO NOT** touch any electrical switch or use any phone or radio in the vehicle.
- **DO NOT** start the vehicle's engine or electric generator.
- Contact the nearest gas supplier or qualified service technician for repairs.
- Contact the nearest fire department if you cannot reach a gas supplier or qualified service technician.
- **DO NOT** turn on the gas supply until the leak(s) is repaired.

– **A qualified installer, service agency, or gas supplier must perform installation and service.**

EXCLUSIONS

Thank you for purchasing this Ranein® product. Before operating your new product, please read these instructions carefully. This will ensure safe use and reduce the risk of injury. In addition, this instruction manual contains information for installation, operation, maintenance of the product, and secure service. Please keep this instruction manual in a safe place for future reference. Also, pass this manual on to any new product owners. The manufacturer does not accept responsibility for damages due to not issuing these instructions.

⚠ WARNING

What to do if you smell gas

- Evacuate all persons from the vehicle.
- Shut off the gas supply at the gas container or source.
- Do not touch any electrical switch or use any phone or radio in the car.
- Do not start the vehicle's engine or electric generator.
- Contact the nearest gas supplier or certified service technician for repairs.
- Contact the closest fire department if you cannot reach a gas supplier or accredited service technician.
- Do not turn on the gas supply until the leaks are repaired.

TABLE OF CONTENTS

Explanation Of Symbols01	Wiring Diagram19
Important Safety Instructions01		
Responsibilities Of The Operator02	Check After19
About Your Product03	Checking For Gas Leak19
Product Over View03	Checking For Water Leaks20
Product Features04	Functional Test20
Basic Function04		
What's In The Box05	Operation Instruction21
Tools Required(Not Provided)06	Controller Operation21
		Safe Operation21
Installation07	For High Altitude Use22
General Installation Safety07		
Prepare Cutout Opening08	Winterizing Operation22
Existing Cutout08	Winterizing Water Heater22
Prepare Utilities10		
Prepare Water Heater13	Storage And Transit24
		For Next Season, Using25
Water Heater Installation13	Routine Inspection25
Gas Connection14	Pressure Safety Valve Maintenance26
Electrical Connection15	Hard Water And Decalcification26
Door Frame Installation16		
Securing The Water Heater16	Troubleshooting26
Wall Controller Installation Steps18	Error Code26
		Troubleshooting27

Explanation of Symbols

This manual has safety information and instructions to help you eliminate or reduce the risk of accidents and injuries.

Always respect all safety warnings identified with these symbols. A signal word will identify safety messages and property damage messages and will indicate the degree or level of hazard seriousness.

DANGER

Indicates a potentially hazardous situation that, if not avoided, could result in death or serious injury.

WARNING

Indicates a potentially hazardous situation that, if not avoided, could result in death or serious injury.

CAUTION

Indicates a potentially hazardous situation that, if not avoided, may result in minor or moderate personal injury or property damage.

Important Safety Instructions

Read these instructions carefully to ensure the safe and correct operation of your appliance. Retain the instruction manual and installation instructions for future use or for subsequent owners.

DANGER

Suffocation or Fire Hazard

- Exhaust gases are hot and contain carbon monoxide, do not breath or obstruct the exhaust gases.

Failure to follow the instruction will lead to serious injury, property damage, or death.

- **Never** use this appliance in enclosed spaces or tents.
- **Always** turn the appliance off, and shut off the fuel supply while parking the RV in an enclosed space, such as a garage or repair shop.
- **Never** place seating or picnic tables in the direct path of the exhaust outlet.
- **DO NOT** use this RV water heater without a working carbon monoxide detector. Instead, follow the manufacturer's instructions and guidelines for its installation.
- **ALWAY** keep the air inlet and exhaust outlet free of obstructions to ensure clean combustion.
- **DO NOT** place articles on or against the appliance.
- **DO NOT** lean any objects against the water heater's access door or place any foreign.
- **Never** use this appliance in enclosed spaces or tents.

- **Always** turn the appliance off, and shut off the fuel supply while parking the RV in an enclosed space, such as a garage or repair shop.
- **Never** place seating or picnic tables in the direct path of the exhaust outlet.
- **DO NOT** use this RV water heater without a working carbon monoxide detector. Instead, follow the manufacturer's instructions and guidelines for its installation.
- **ALWAY** keep the air inlet and exhaust outlet free of obstructions to ensure clean combustion.
- **DO NOT** place articles on or against the appliance.
- **DO NOT** lean any objects against the water heater's access door or place any foreign objects within 24" (610 mm) of the access door.
- **DO NOT** use or store flammable materials near the appliance.
- **DO NOT** spray aerosols near the appliance while it is in operation.
- **DO NOT** modify the appliance.

Responsibilities of the Operator

- The operator is responsible for their health and safety; persons with pacemakers should discuss with their doctor before opening the access door or performing service repairs.
- The operator is responsible for the water quality used in the appliance.
- The operator is responsible for all routine inspections in this manual's Cleaning and Maintenance section.
- The operator is responsible for using and maintaining gas cylinders as specified by the RV manufacturer.
- The operator is responsible for ensuring that no spray water enters the appliance when cleaning the RV.
- The operator is responsible for using the appliance for potable water only. In addition, they are responsible for ensuring that non-potable water sources, components, or heating systems, new or old, are not connected by any means to the appliance.

While Driving

- The operator ensures all components are seated and locked before moving the RV. Check the following:
 - The access door is flush with the mounting plate.
 - Door locker is engaged.



The operator is responsible for ensuring the gas system is turned off at the gas cylinders before transit. Turn off all necessary valves as indicated by the RV manufacturer.

The operator is responsible for ensuring the appliance is off when refueling, traveling through tunnels, parking in garages or carports, or ferries.

Access Door

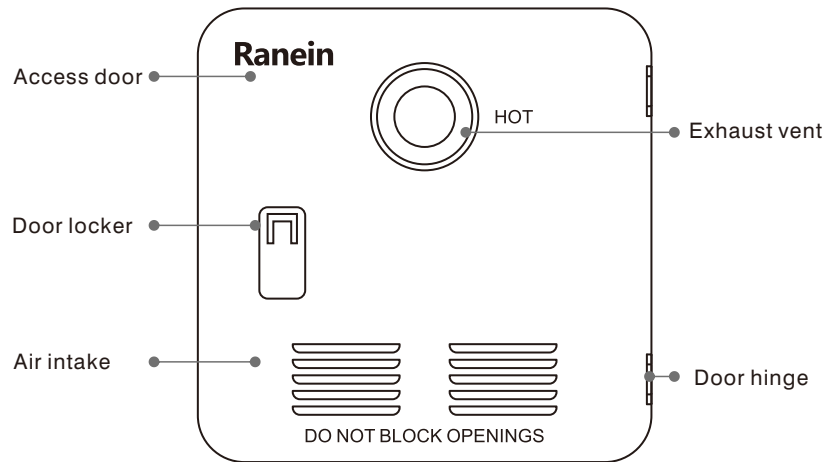

Connection for water and gas supply

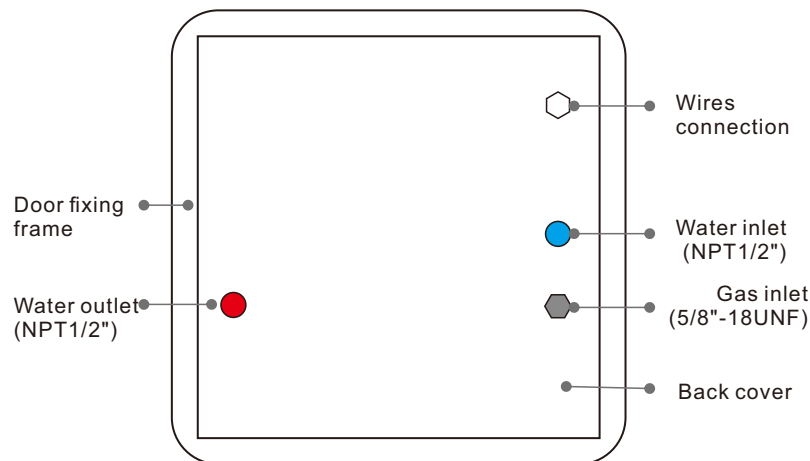

Product Features

The appliance is equipped with the following safety devices:

- **Flame monitoring device**
If the flame goes out, the device switches the gas supply to the burner.
- **Anti-freeze function**

The appliance is equipped with an anti-freeze device. When the outdoor temperature drops below freezing, the unit will automatic heating the water system to 32 degrees Fahrenheit then the team will stop (Note: Need to turn on the power and gas supply during the anti-freeze time).

- **Power positive and negative wires reverse protection**
If the mighty positive and negative connection cables are changed, the unit will reduce the ability to protect the PCB.
- **Low-voltage/over-voltage shutdown**

The appliance shuts off if the voltage drops below 10V DC (or rises above 17V DC).

- **Over-current protection**
If there is a short circuit in the appliance (> 10 A), a fuse on the control unit is activated, and the appliance is switched off.
- **Hot water temperature monitoring**
A water over-temperature switch avoids excessively high water temperatures in case of an error.

- **Flue fan monitoring**
If the flue fan fails, the gas supply to the burner is switched off.
- **Temperature fluctuation eliminator**
The appliance is equipped with a temperature fluctuation eliminator. For example, suppose the water flow is suddenly decreased to a small flow (0.4 GPM), which will cause a high rise in temperature. In that case, the fluctuation eliminator can eliminate the rising temperature to avoid scalding injuries and ensure the bather gets a comfortable bath.

- **Over pressure protection**
The appliance has a pressure relief valve that complies with the Relief Valves for Hot Water Supply Systems standard, ANSI Z21.22.

Basic function

The appliance was designed exclusively for use in recreational vehicles. The apparatus connects the vehicle's fresh water supply and hot water plumbing system. Based on the hot water demand, the tankless water heater will heat incoming cold water to the desired output temperature by monitoring critical sensors to regulate the thermal energy released over a large heat exchanger. This creates a more valuable and energy-efficient heating system versus the conventional tank water heater that wastes fuel during re-heat cycles and is limited in volume output.

What's in the Box

Remove product from packaging and ensure you include the following list of items. If any item is damaged or missing, contact your Ranein dealer.



Main body x 1



Wall controller x 1



Door assembly x1



ST4.2x30 screws
SUS430 ST4*30
(door fixing) x 14



ST4.2x20 screws
(controller fixing) x 2



Wire connectors x 6



Use and care manual x 1



Warranty card x 1

Product specifications

Specifications		
BTU/HR (Nominal input rate)	65,000 BTU	
Hot water capacity (Gallon/m, @ Δ45°F)	2.64	
Fuel type	Propane (LP Gas)	
Fuel inlet pressure	10.5 in.wc-14 in. wc / 2620Pa-3490Pa	
Manifold pressure	0.85 in.wc-6.4 in.wc / 210Pa-1600Pa	
Power input	12V DC<3 Amp	
Water operating pressure	10 PSI-65 PSI	
Burner orifice (mm)	5 x Ø1.2	
Working altitudes: 0-2000ft (0-610m)	Manifold Pressure (Pa)	1600
Product dimensions (W x H x D)	12.6" x 12.5" x 14.74"	
Assembly (body and door) dimensions (W x H x D)	Body with Door	15.2" x 15.1" x 15.4"
Installation cutout and depth dimensions (W x H x D)	12.8" x 12.7" x 19.7"	
Shipping weight (lbs/kg)	29.8/13.5	
Setting temperature range	95°F (35°C)~124°F (51°C)	

WARNING

Suffocation Hazard

- Dispose packaging material or keep from reach of small children. Failure to follow instruction could lead to serious injury or death.

Tools Required (Not Provided)

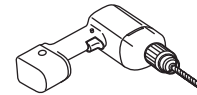

Electric drill
Bit size: 1/16" (3mm)

Note: It is use for holes drilling of exterior sheet metal of RV.



Gloves

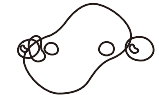

Soapy Water

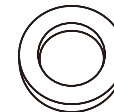

Washers



Butyl tap

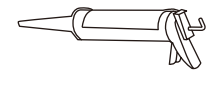

Sealant Gun

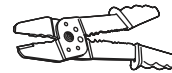

Wire Stripper Pliers



Adjustable Wrench x 2

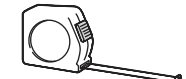

Tape Measure



Pencil



Phillips Screwdriver



Flat Blade



Cutting Knife



Eye Protection

Installation

⚠ DANGER

Observe all installation material by governing codes and ordinances. Failure to follow instructions will result in serious injury, property damage, or death.

General Installation Safety

⚠ WARNING



Electrical Shock and/or Fire Hazard

- Disconnect power before installation.
- Turn off all gas to the supply system.

Failure to do so can result in serious injury or Death.

⚠ WARNING



Always wear protective gear such as gloves, eyewear and clothing to avoid injuries during installation and servicing of the product.

For Recreational Vehicle (RV) installation only!

- A qualified person must perform any installation by this instruction manual.
- **DO NOT** use test pressures higher than 40in-wc (1.45PSI) to test the gas leaks.
- **DO NOT** attempt to modify the appliance.
- **DO NOT** alter the appliance for a positive grounding battery system.
- **DO NOT** move the appliance by grabbing the interior components.
- Make sure all exhaust gases are directed outside the RV.
- Protect all combustible material from exhaust gases.
- **DO NOT** draw air for combustion from occupied spaces.
- Always disconnect the 12V appliance (to protect the control from surges that may occur) when performing Dielectric (hi-pot) testing, welding, electrical, etc... work on the coach.
- Only use a proven 12V power source such as a battery or approved converter.
- **DO NOT** vent the water heater using a venting system serving another appliance.
- **DO NOT** install directly into a shower or near direct heat.

Prepare Cutout Opening

1. Choose a location to place the appliance based on the following criteria:
 - **DO NOT** install on the rear or front of the RV to minimize contamination from road grime, debris, and wet roads when traveling.
 - **DO NOT** install the appliance in an outdoor enclosed area.
 - **DO NOT** install the appliance in any location where the exhaust vent may be covered or obstructed when a swing door, bag door, slide-out, pop-up, etc., is partially or fully

extended.

- **DO NOT** install this appliance on any door or slide-out area.
- **DO NOT** install the appliance where the access door is less than:
 - 9" (229mm) from any opening into the vehicle.
 - 36" (914) from any motor-driven air intake.
 - 36" (914mm) from any gas tank connection or ventilation.

RV edition for specific requirements. Choose a convenient location where supply water, LP gas, and 12V DC are accessible to the back side of the appliance for installation and servicing.

The water heater is designed to be installed on a flat floor (made of Wood or Linoleum) or a fixed platform.

It is recommended that the appliance be located in a central location to the hot water loads.

Choose a location where clearances to combustible surfaces and the appliance are:

1" to the top surface.

0" to all other surfaces.

NOTE: To install on a carpeted area, a metal or wood panel that extends at least 3 inches beyond the width and depth of the water heater is required to install under the unit.

2. Create a cutout with the following dimensions A and B of Fig.

- **NOTE:** The opening for the water heater should be right angle corners.

3. Make sure that the front edge of the opening is surrounded by a solid frame to firmly anchor the water heater. Construct the space using 1.5" x 1.5" min if needed—wood or aluminum framing.

Existing Cutout

1. Determine your existing cut-out.

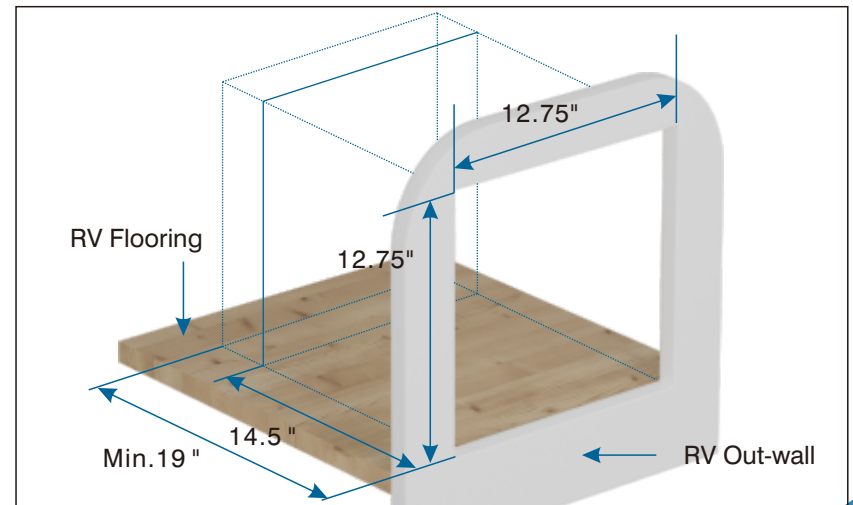

NOTE:

Fiberglass, film, and corrugated aluminum (Mesa 1") are all acceptable exterior wall siding solutions.

The exterior wall opening must be the exact dimensions with no radius corners.

4. Refer to depth "C" for minimum rear clearances for cabinets, appliances, and utility entry locations.

5. for adequate spacing from other items on the RV wall to the door assembly.

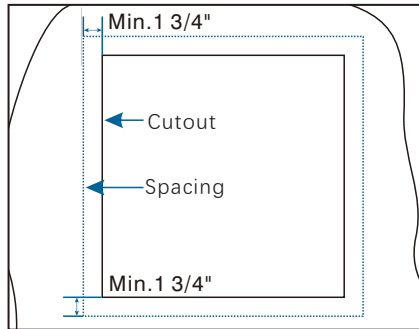

6. Ensure a solid floor or platform with adequate weight-bearing capacity supports the appliance.



7. If necessary, create a platform to support the water heater, are some common solutions. Ensure the platform is level front to back, and side to side after securing the RV.

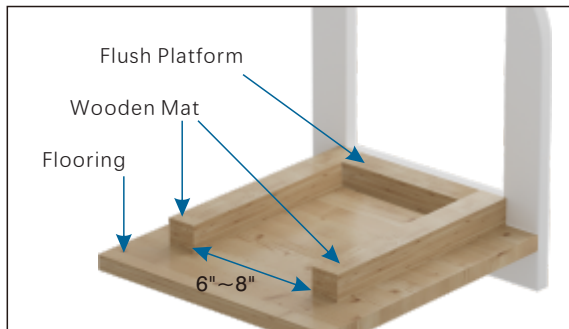
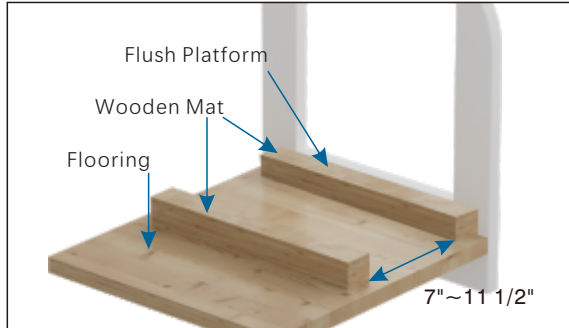

Prepare Utilities

a general connection diagram.

Gas Connection

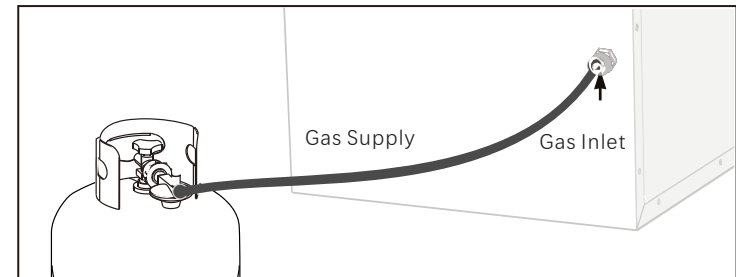

Electrical wiring

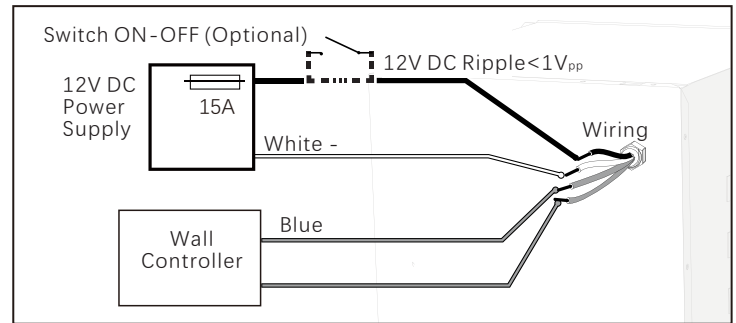

Water plumbing

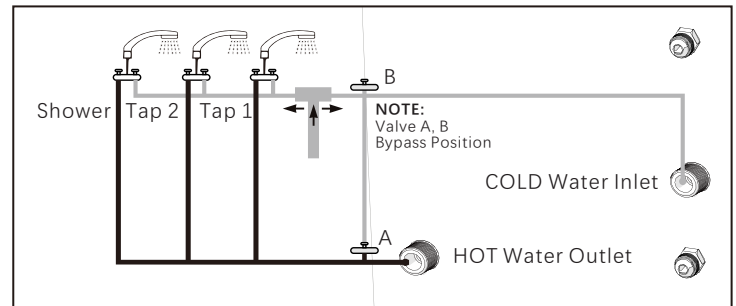

NOTE:

- The drawings are not intended to describe a complete system. The installer is responsible for determining the necessary components for a working system.
- The drawings do not imply compliance with state or local code requirements or regulations. It is the installer's responsibility to ensure that the installation is in full compliance with all state or local code requirements or restrictions.
- **Optional:** The bypass valve can be installed to facilitate winterizing the coach. It is not required, as antifreeze can be used in the appliance. However, additional antifreeze (about 1L) is needed to fill the volume. Refer to the winterizing section of this manual for instruction methods.

Gas Plumbing

DANGER

Fire or Explosion Hazard

- Follow all applicable codes, regulations, and instruction material when performing service work.

Failure to follow instructions will result in product damage, serious injury, or death.

- Fuel entering the appliance must be in the gas phase. The liquid phase must not be used and will damage the product.
- This appliance is rated for 65,000 BTU/HR, 11~14in-wc. (27.4~34.9mbar). Follow NFPA1192 and Z240 RV series for proper pipe sizing based on additional gas-burning appliance loads.
- Use LP gas (propane) only. Butane or any mixtures containing more than 10% butane must not be used.
- The gas line must terminate with a 5/8 UNF flared female compression fitting to connect with the rear gas connector of the appliance.
- A non Metallic Flexible gas hose must be rated for 149oF (65oC). Anchor appropriately to prevent fatigue and failure from worn edges.
- Make sure that the operating pressure of the gas supply corresponds to the operating pressure of the appliance 11~14in-wc (27.4~34.9mbar).

Locate the entry point for the plumbing to service the appliance's rear. Ensure the entry point is outside the footprint space of the apparatus.
Feed gas line into proximity, leave enough length to flex into position so that no kinks are created when connected.

Note: An approved semi-flexible metallic pipe can connect as an extension from the gas line to the appliance.

- Terminate the gas line with fittings to connect to the appliance.

Electrical Wiring

WARNING

Electrical Shock Hazard

- Disconnect all power before performing any work.
- Always use a certified and proven 12V isolated power supply that is properly grounded to the RV.

Follow all applicable codes, regulations, and instruction material when performing service work.

Failure to follow instructions could result in serious injury or death.

- Wiring connected to or near the appliance must be rated for 140°F (60°C) minimum.
 - Use only insulated terminals for all electrical connections.
 - The appliance requires a power source that adequately provides 10~17V DC to function correctly. Contact Ranein for available Power centers, converters, and distribution panels.
- Select a distribution branch greater than 3A, preferably 15 amp, to provide a nominal 12V to the appliance from the distribution panel.
- Note:** The appliance has a built-in 10A fuse, serviceable from the front of the product. The apparatus can be on a dedicated or shared branch circuit with the same

or higher rating.

- Optional:** A power switch can be placed in the living quarters for convenience, but not required as a button is located externally on the appliance. If the switch is fused, ensure it is rated for at least 3amps.
- Locate the entry point for the wiring to service the rear of the appliance. Ensure the entry point is not in the footprint space of the apparatus. Make sure any edges are protected to prevent wire abrasion from occurring.
 - Determine the appropriate wire gauge (AWG) for the 12V power supply length. Ensure enough wire is available to make the adequate connection.
 - 16AWG max. 40 feet (12m)
 - 14AWG max. 66 feet (20m)
 - Feed wire from the power source to the entry point. Make a connection to the power source.

Water Plumbing

- The plumbing must be rated to supply between 35-70PSI nominal.
 - Connections can be made using PEX swivel nut adapters with NPT straight threads and a cone seal or standard 1/2" FPT fittings.
 - This water heater requires a minimum water flow of 0.32 Gallons per Minute (GPM) for proper operation.
- Locate the entry point for the plumbing to service the appliance's rear. Ensure the entry point is not in the footprint space of the apparatus.
 - Create a piping layout to supply the appliance and all faucets.
NOTE: Dry fit tubing and fittings before clamping together. Adjust sections to avoid excessive stress on the fittings when assembled to the appliance. It may be helpful to fit the device into position to determine the appropriate piping layout.
 - Clamp and seal all fittings together. Terminate piping with the appropriate fittings.

Prepare Wall Control

- Determine a location to install the wall controller inside the RV.
- Drill a 3/4" hole and clean the edges.
- If necessary, run two electrical wires that extend the wall control connections (blue cables) to the appliance connections (blue wires) using the appropriate wire size. 16AWG max. 65ft (20m).

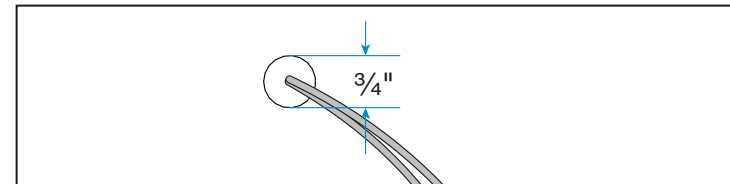

Fittings for water inlet and outlet

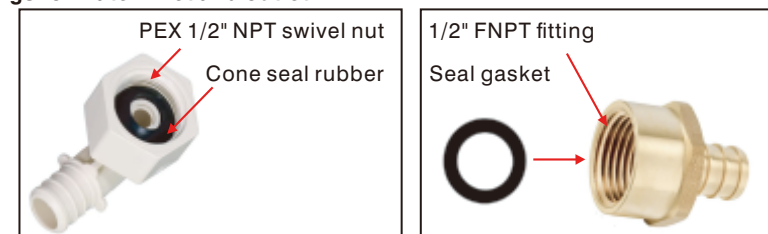

Prepare Water Heater

1. Take the water heater out of its packaging by grasping the metal sides of the housing and lifting upward until entirely removed from the box.
2. Remove protective caps for COLD, HOT water connector, and GAS connector from the back side.

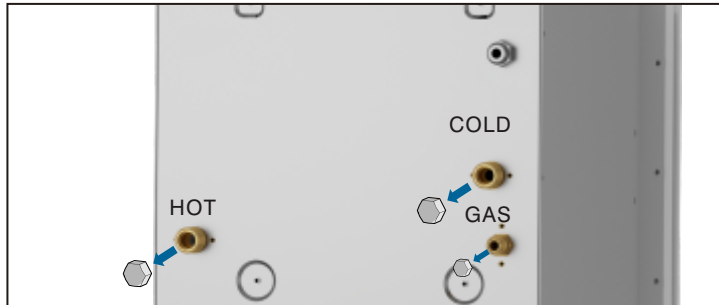

Water Heater Installation

1. Apply adequate water sealing material, e.g. butyl tape (recommended width: 1", not provided), around the entire backside flange area and holes.
 - NOTE:** Do not use adhesive sealing material, e.g., silicone, for the watertight seal.
2. Position the water heater carefully into the frame opening, and evenly space the flange to the exterior wall of the RV.
 - Note:** Ensure the area beneath and behind the appliance is clean without debris and obstruction. Carefully slide the device across the floor to prevent linoleum damage.

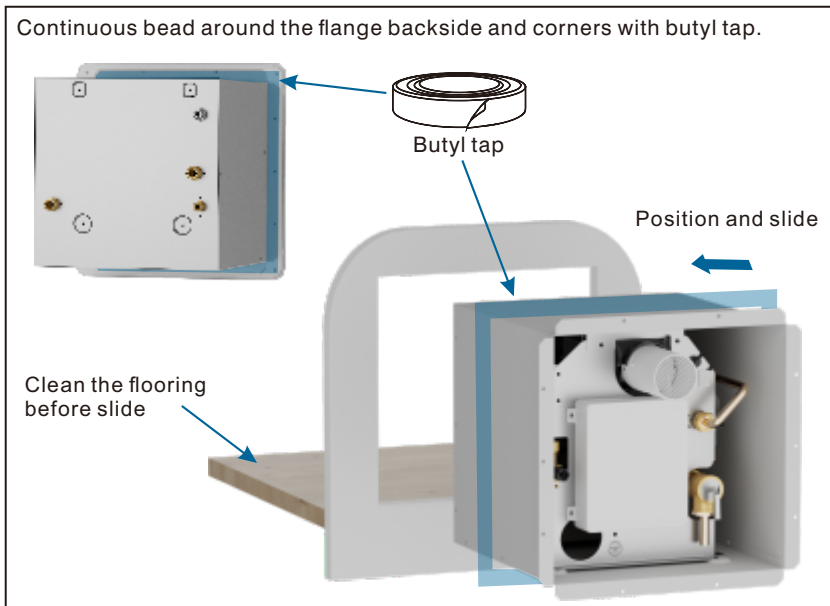

Check the sealing between the backside flange and the out wall. May sure the flange touches the RV's out wall.

NOTE:
It will cause leakage if there are gaps between the flange and out wall.

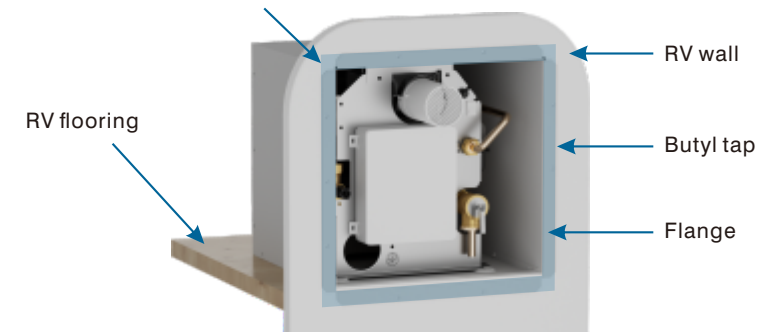

Water pipe\Gas Connection

Connect the Water pipe\gas service line to the Water pipe\gas-flared fitting on the back of the appliance. Use two wrenches to tighten the compression fitting. Avoid damaging the unit by overtightening.

NOTE: Do not use sealing tape or compound on the compression-type fitting.

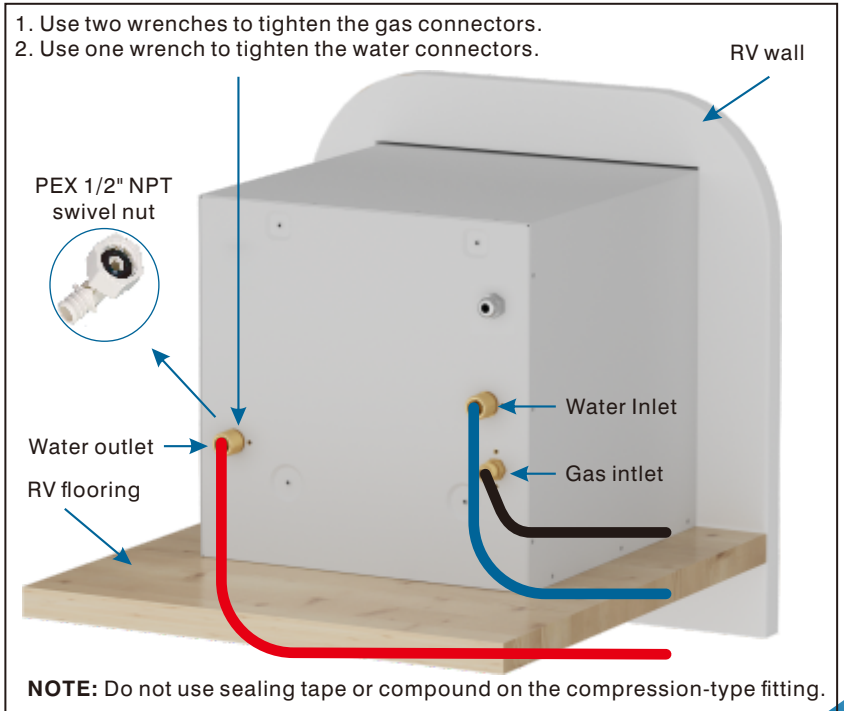

NOTE: Do not use sealing tape or compound on the compression-type fitting.

Electrical Connection

1. Set the power switch before the water heater to the "OFF" position.
2. Connect the power supply wires (on the rear of the water heater- white and black wire) to the appropriate nominal 12V DC power source connection.

Note: The black wire is positive (+), and the white wire is negative (-).

3. Connect the wall controller wires (2 blue wires on the appliance).

Note: Polarity does not matter. The wires can be connected to either blue cables.

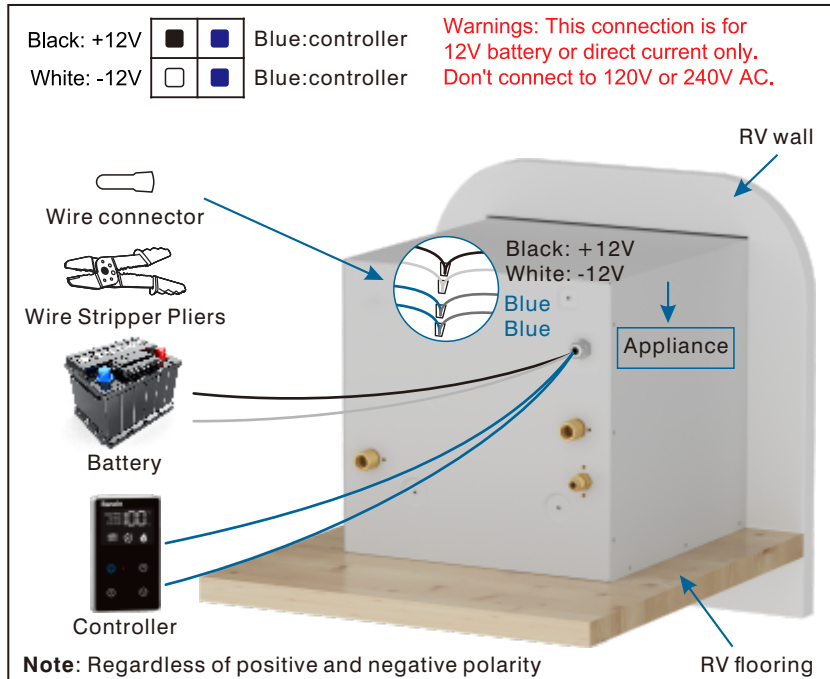

Drill 14 holes on the metal board of the RV out the wall with a 1/8" (3mm) bit.
Note: Drill the metal board only—no need to drill the inner wooden or heat insulation layer.

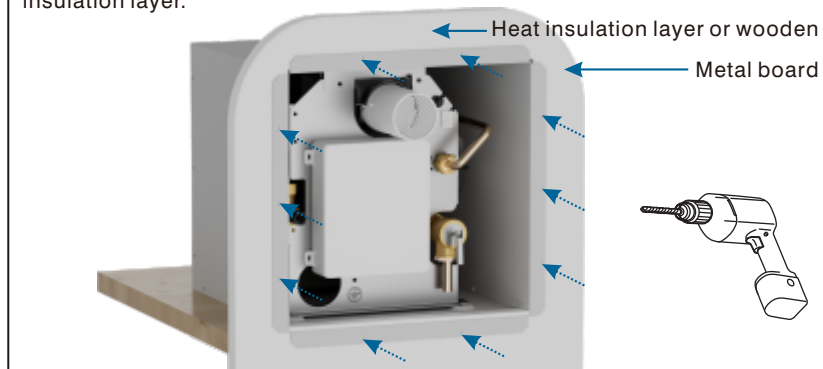

Door frame installation

1. Unpack the door assembly from the package.
2. Lift the handle of the door lock by finger.
3. Rotate the handle at 90 degrees angle.
4. Open the door.

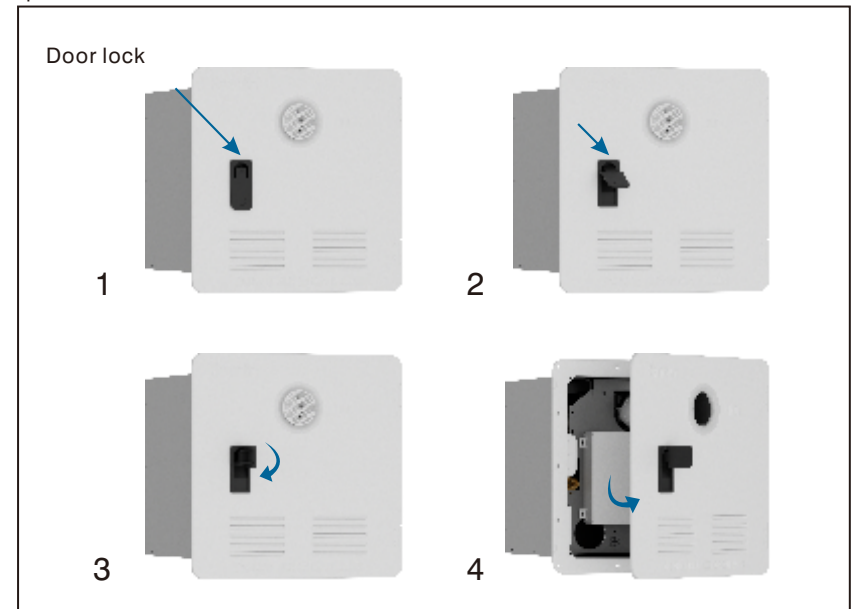

Securing the Water Heater

1. Insert the door flange into the water heater housing and press the flange firmly against the sidewall.

Pre-install the door frame and make sure each hole is aligned to the flange hole.

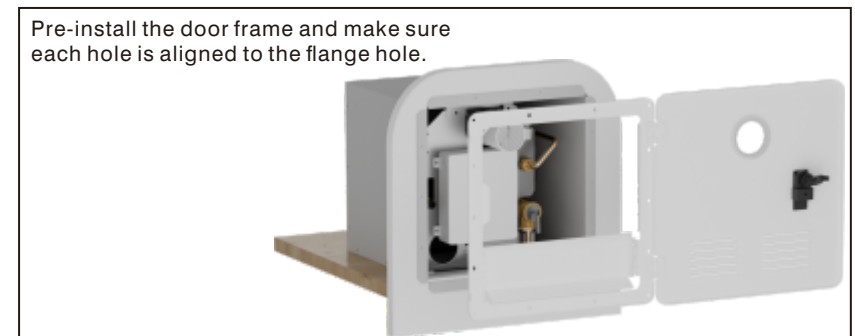

2. Secure the flange to the vehicle using 12 - #8 (min 1") pan head screws (not provided) through each hole along the perimeter. Verify that a tight seal exists between the side wall and the flange.

Note: Ensure the butyl tape completes a tight seal between the RV siding and appliance flange. If gaps exist, remove the appliance and apply a double layer of butyl tape.

Fixing door frame with ST3.9*30 mm self screws(14Pcs).

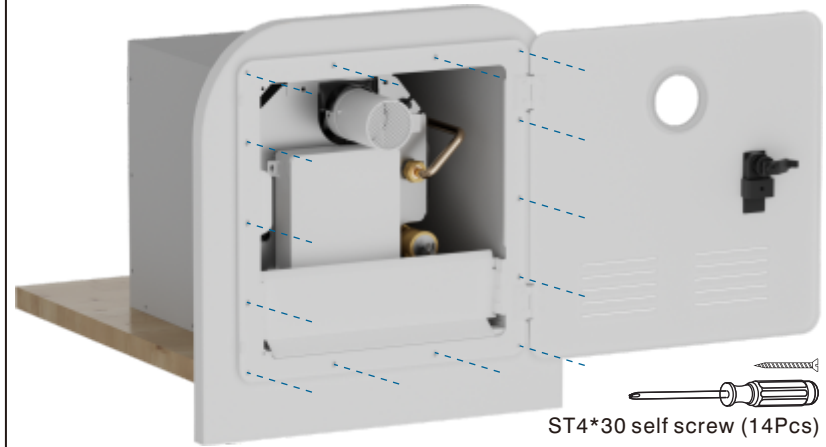

3. Apply a liberal amount of sealant around the door frame to fill any gaps in the RV wall. Wipe any excess adhesive.

Apply sealing material at the adage of the door frame(for better waterproofing). Remove excess sealing material after sealing.

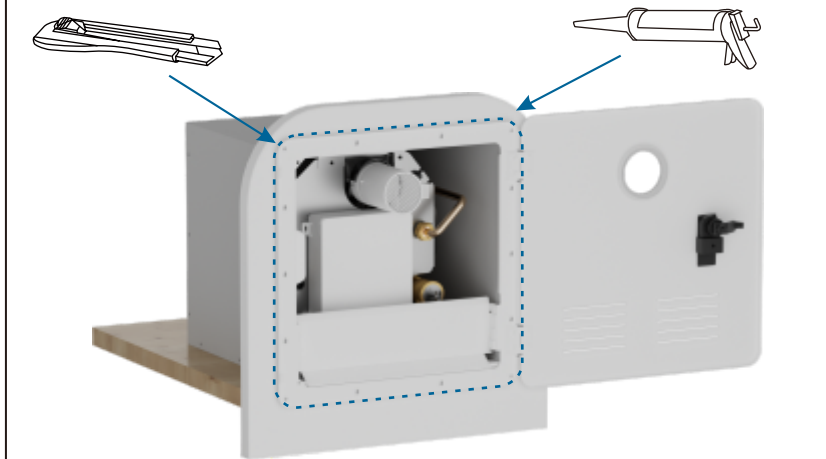

Wall controller installation

1. Disassemble the wall controller.

1. Press and push up the buckle of the wall controller.
2. Open the cover with a finger or with a flat blade.



2. Install the back cover of the wall controller.

Install the back cover of the wall controller over the 3/4" hole. Fix the back cover on the wall with 2-st3.9*20 screws.

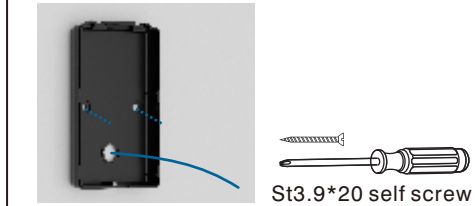

3. Assemble the controller cover.

Assemble the cover again after fixing the back cover.



Wiring Diagram

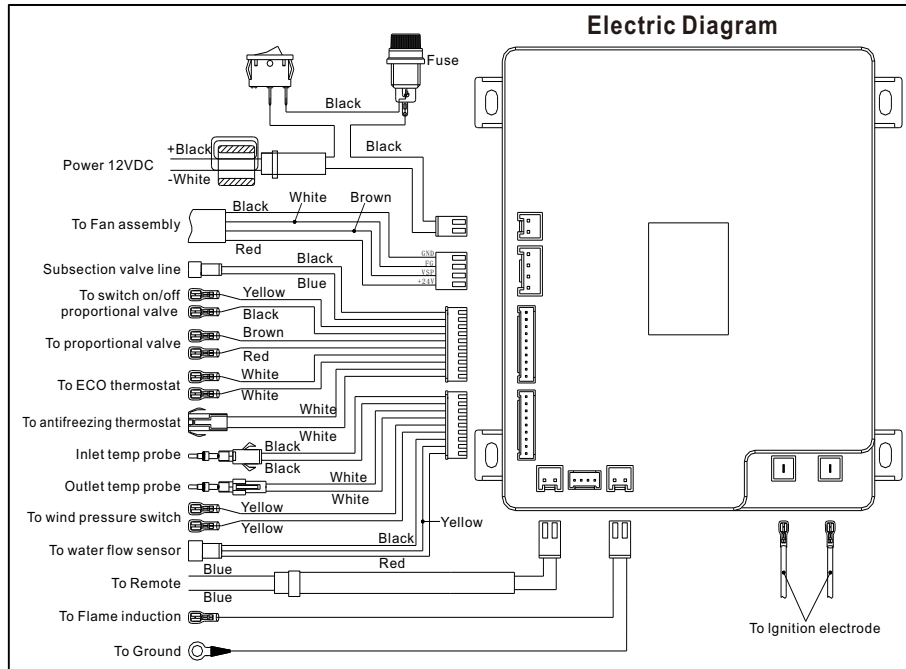

Check After

Checking for gas leak

⚠ WARNING

Risk of death and personal injury through fire and explosion!

- **DO NOT** use matches, candles, or other ignition sources when checking for gas leaks.
- After the gas supply is connected, check for gas leaks at all gas connections. Use a gas leak detection liquid or equivalent. Ensure test pressure is below 40 in.wc (100kPa)
- Make sure to re-test all fittings after making adjustments to loose connections.
- Failure to follow instructions may lead to serious injury, property damage, or death.

1. Turn on the gas supply or alternative pressure supply.
2. Check the appliance and all gas connections for gas leaks with leak detection liquid (not provided) or an equivalent gas leak detection method. Bubbles indicate a gas leak that must be repaired.
3. Repair gas leaks as needed.
4. Repeat the gas leak check after any adjustments to loose connections.

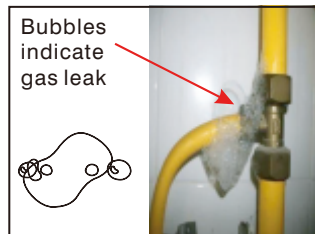

5. Note: After leak checking, ensure the gas supply pressure corresponds to the operating pressure of the appliance 10.5~14 in.WC (2620Pa~3490Pa).

Checking for water leak

1. Verify that the power switch on the water heater is in the "OFF" position.
2. Turn on the water supply to the appliance.
3. Open water faucets to fill the system with water. Close the taps when the water flows smoothly and all air is removed from the lines.
4. Check all connections for water leaks by eye and touch.
5. Repair water leaks as needed.
6. Repeat the water leak check after any adjustments or loose connections.

Functional Test

⚠ WARNING

Fire or explosion hazard

- Ensure all necessary system leak tests are complete before operating any functional test.
- Failure to follow instructions could lead to serious injury, property damage, or death.

Prepare

- Verify that the power switch is in the "OFF" position.
- Confirm that there is a "steady" water flow (not pulsating) and no air in the system. If pounding, have the water pump settings adjusted?
- Make sure all valves that can mix cold and hot water are shut.
- **Note:** Outside faucets with detachable spigots and shower heads with flow interrupters can bleed hot water into the cold side if the valves are not closed properly. This will hinder the performance of the water heater.

Start to work

- Turn the power switch to the "ON" position on the appliance and verify that the wall controller is illuminated. If the wall controller is not illuminated, press the button on the wall controller to describe it. The controller display will show the hot water temperature.
- **Note:** The default factory setting is 108°F or 42°C.
- Turn on the gas supply.
- Open a hot water faucet and verify that the unit ignites and supplies hot water at the tap.
- The wall controller display will show the current temperature settings.
- **Note:** If any error codes or performance concerns, refer to the troubleshooting section of this manual.

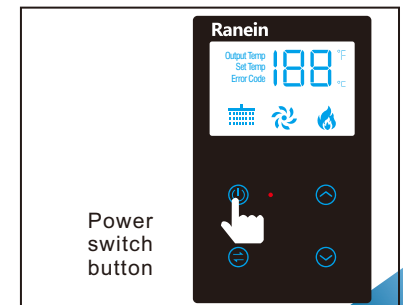
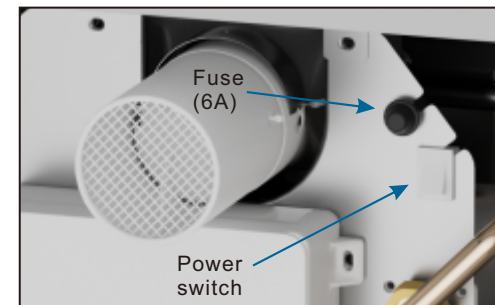

Operation Instruction

Controller operation

Before regular operation of the appliance, perform a basic functional test check out each time the RV and water system is set up for use (May be sure electric, water, and gas supply are standard).

1. Touch to turn on the power. The display will show the current temperature setting.
2. The touch button will transform the temperature display to °F or °C. Please see the below picture.
3. Touch the button to adjust the temperature to your desired settings. The wall controller settings are from 95°F (35°C) to 124°F (51°C)). The default setting temperature from the factory is 108°F (42°C).

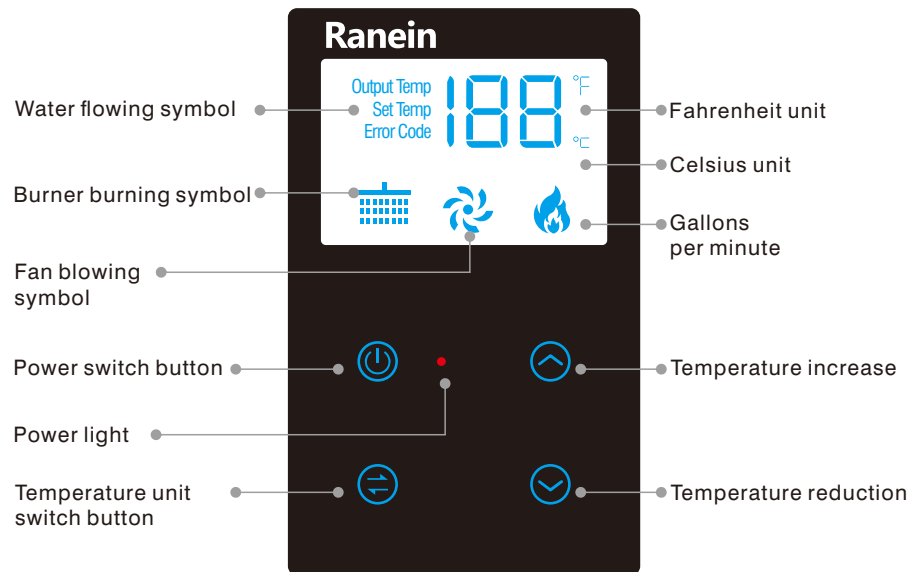

Safe operation

⚠ WARNING

Scald hazard

- Never let infants, children, elderly adjust the water temperature or be left unsupervised when using hot water.

Failure to follow instructions may lead to serious injury.

Consider the following points for the safe use of the appliance:

1. First, install an RV water regulator to the inlet of the coach, and operate between (35-70PSI) water pressure.
2. The factory default water temperature setting is 108°F (42°C).
3. There may be a variation between the temperature delivered from the appliance and the temperature at the faucet due to water conditions between seasons, like hot summer or the length of pipe from the apparatus.
4. Always check the water temperature, about the chart below, by the display and hand touch before bathing or with other hot water uses.

Temperature °F (°C)	Time before skin becomes scalded
155 (68)	1 Second
148 (64)	2 Seconds
140 (60)	5 Seconds
133 (56)	15 Seconds
127 (52)	1 Minute
124 (51)	3 Minutes
120 (48)	5 Minutes
100 (37)	Safe Bathing Temperature

Source: Moritz, A.R. / HERRIQUES, F.C.: Studies of thermal injuries: the relative importance of time and surface temperature in causation of cutaneous burns A. J. Pathol 1947; 23: 695 - 720.

For high altitude use

This appliance can be used at high altitudes and has been tested up to 2000ft. For prolonged use at higher altitudes, please get in touch with service@raneinrv.com Cleaning and maintenance.

⚠ WARNING

Burn or scald hazard

- Never perform work while the water heater is operating.
- Never perform work without turning the Electrical and LP gas supply off.
- Never perform work when the appliance is hot.
- Never actuate the pressure relief valve as long as the appliance is hot.
- Never actuate the Drain Plug if the appliance is under water pressure and/or is still hot.

⚠ CAUTION

Sharp edges can cause cuts and injury

- Always wear protective gear such as gloves to avoid injuries from sharp edges during installation work and while handling the appliance.

Winterizing water heater

⚠ CAUTION

Product damage due to frost condition ❄

In frost conditions, with ambient temperatures below 39°F (4°C), there is a risk that water in pipes, faucets, and appliances could freeze. This can cause considerable damage.

Automatic winterizing:

The appliance is equipped with an Automatic antifreeze device. When the water temperature drops to 43, the apparatus will start to work. Until the water temperature reaches 90, the appliance stops working. This is a cycle of work.

Consider the following points for the safe use of the appliance:

Note: The appliance's electric and gas supply must be turned on, and the controller can be turned off (on standby). If the electric and gas supply is not provided, the automatic winterizing device will not work.

Manual winterizing operation:

To winterize the appliance for a long time or storage, you must drain all water from the instrument. To do this, we advise the following steps:

Winterizing the RV by draining water:

1. Close valves A and B, open valve C at the back of the appliance.

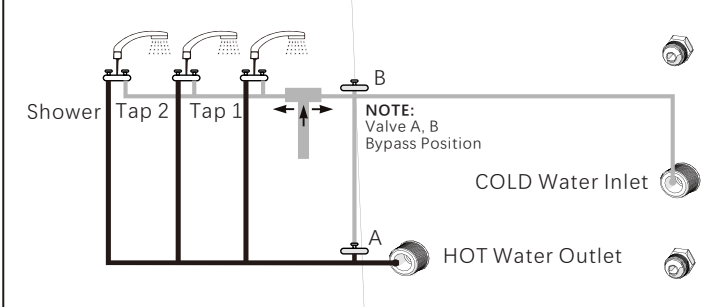

2. Open the door and pull out the baffle from the door frame.

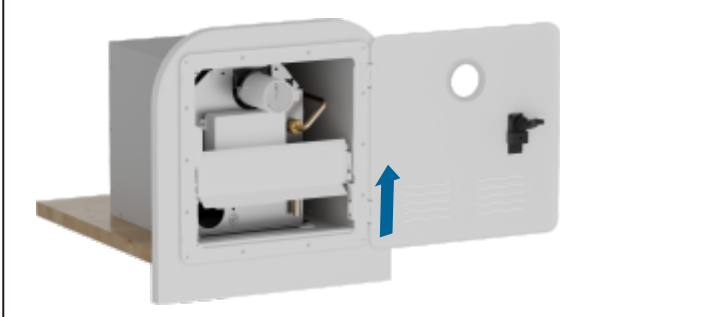

3. Open the safety valve by hand and allow the water to drain completely from the unit. Unscrew the water inlet filter to clean the filter.

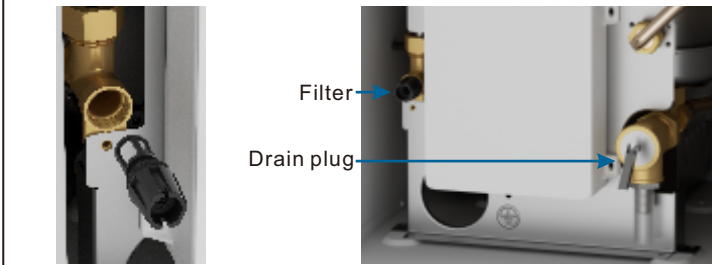

4. sure the water in the appliance has totally drained. Then screw the drain plug and the filter again.

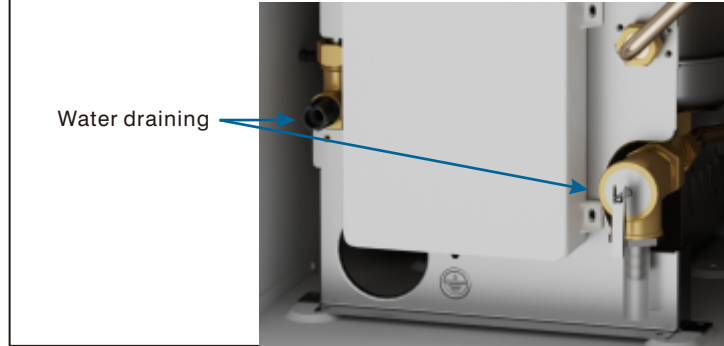

5. Flush the RV's water system with a suitable winterizing fluid according to the supplier's or RV manufacturer's guidelines.

Note: The appliance is protected against freezing conditions once the water has been drained.

Winterizing the RV with a winterizing fluid:

- Winterizing the RV with a winterizing fluid is only possible with an installed bypass kit (not in the scope of delivery).
- Follow the instructions provided by the RV coach manufacturer for the winter water system.
- Supplement the following important water heater instructions when completing any winterizing steps:

Compressed air pressure for blowing water heater:

- **DO NOT** exceed 30PSI when air pressure is in the water heater.
- While completing the blowout process for the entire water system, take time to isolate the water heater by closing all drain plugs and faucets and only open the water heater drain plug and filter cover. This ensures maximum pressure and flow are isolated through the water heater for complete evacuation.

Anti-freeze:

- Use a non-toxic antifreeze recommended by the RV coach manufacturer.
- Antifreeze can be used directly in the water heater. Plan for an additional 1L to fill the system.

Optional:

- A bypass valve can be installed or used to bypass filling the water heater with antifreeze. Before bypassing, the water heater must be evacuated with compressed air (see steps above).

Storage and transit

Anytime the RV is not intended to be used, it is considered in storage or transit. To prepare the water heater, follow the below steps: 1. Turn off the gas supply. 2. Turn off the water heater main switch. 3. Drain the water out of the system and water heater by removing the filter cover and drain plug. If freezing conditions could occur, then winterize according to the "Winterizing Water Heater" (Refer to the above operation).

For next season using

- Thoroughly flush the water heater and system with clean drinking water through the hot and cold sides before using. Drain water several times out of the water heater drain plug. Sanitize the water system per the recommendations of your coach manufacturer.

Routine inspection

Routine inspection is critical for maintaining the proper operation of your appliance. Unless specified, review the following items yearly or before each season:

- Inspect the gas system, water system, and installation every two years or otherwise restricted by your RV coach manufacturer by a qualified person.
- Inspect for cracks, separation, and peeling of seals to the RV wall. Remove and re-seal as necessary (caulking or tape) between the side wall and the water heater door and ensure that the unit is solidly mounted to the vehicle.
- Before actively using your vehicle, pre-inspect that the air intake openings (louvers) are completely open and clear of any debris, including mud, leaves, twigs, insects, etc... Remove all obstructions to allow total airflow.
- Before actively using the vehicle, open the door and verify that no debris or extraneous combustible materials are present anywhere (especially in the area of the burner and the gas controls). Remove any item present and wipe clean the bottom of the housing.
- Before actively using the vehicle, verify that the exhaust tube and screen are completely clear of obstructions, including mud, leaves, twigs, insects, nests, etc. Clean by gently breaking it up and using a vacuum to clear it. Use only water and apply gently from a spray bottle. Never spray directly with high-pressure water. Next, run the appliance to dry any moisture and blow out loose debris. Using any aftermarket protective screen is prohibited and will void the warranty.
- Inspect the interior surface of the housing for any cracks or corroded areas that could allow the penetration of gases into or out of the vehicle's interior. Check especially around the hot water, cold water, gas, and electrical connections.

Note: If damages are found, please get in touch with a technician to repair or contact Ranein customer service.

- Check that all wire connections are firmly in place and that there are no signs of chafing or cracks on the insulation. Verify that the spark ignition cable between the Control Board and the igniter is securely in place and not shorted to any metal component.
- Inspect the pressure safety valve to ensure it has not been leaking (no water residue). See "Pressure Safety Valve Maintenance" for further inspection.
- Inspect/clean/replace the water inlet filter as necessary. Use a brush to clean the filter.

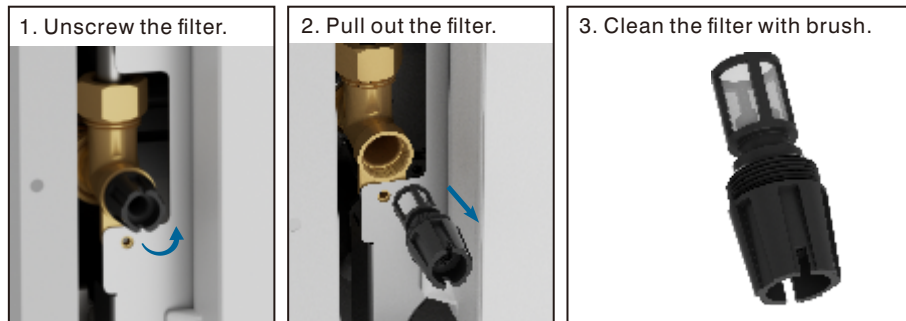

⚠ WARNING

Burn or scald hazard

- Never actuate the pressure relief valve while the appliance is in operation.
- Never tamper with the pressure relief valve.

Pressure safety valve maintenance

- The unit is equipped with a water pressure safety valve. The pressure safety valve must operate once yearly to ensure this safety device is effective.
 - The pressure relief valve is a safety component and must not be removed for any reason other than replacement.
- Note:** A certified service technician must replace the pressure relief valve if defective.
- Tampering with the pressure relief valve will void the warranty.
 - Lift the pressure safety valve handle upward and check if water is dripping out of the pressure safety valve.

Hard water and decalcification

When exposed to higher water hardness concentrations for prolonged usage, it is advised to provide a proper water treatment device for the incoming water to the coach. Hard water may lead to performance reduction of your appliance overtime.

Contact Ranein for decalcification instructions.

Recommended decalcification frequency per year

Water hardness mg/l CaCO ₃	Very hard: > 180	1	2	4
	Hard: 121-180	1	1	3
	Moderately hard: 61-120	1	1	2
	Soft: 0-60	1	1	1
	Use*	low	normal	high

Troubleshooting

Error Code

If the appliance malfunctions, a beep alarm will sound, and the error code will display on the wall controller. Write down the code, then try resolving by stopping and restarting the water flow several times or resetting the appliance as follows:

Switch the power switch in front of the water heater to the "OFF" position (Need to open the water valve and shower).

- Wait 5 seconds.
- Switch the appliance on again.
- Continue to use the appliance usually. However, if error fault codes continue to display, review the following table for potential causes.

Error Code	Possible cause	Solution
Eu: Under-voltage and over-voltage protection	Undervoltage: voltage drops to 9.5±0.1V and then rises to 10±0.1V; Overvoltage: the voltage rises to 17.3±0.1V and then falls to 16.7±0.1V	Check the vehicle voltage and exclude unstable voltage.
En: Timing time is up	Set the end of a device runtime	Rebooting the device

Error Code	Possible cause	Solution
E0: Water outlet temperature sensor fault	Temperature sensor or system failure.	Check the water outlet temperature wires connection. If it loosens, tighten it. If not, the outlet temperature sensor may fail. Replace it.
E1: Flame sense fault	Insufficient fuel supply to start operation.	Confirm all gas valves are open and restart the appliance 4-5 times (First time for using). Confirm adequate fuel in tanks.
	Low gas inlet pressure.	Check regulator for operation, replace if needed.
	Flame sensor or system failure.	If the flame sensor induction or PCB board is broken, it need to be replaced by one of them.
E2: Detected fake flame signal	Flame sensor or system failure.	PCB primary control board failure or program faulty. Replace the main control board.
E3: Over temperature mechanical sensor fault	Thermostat system fault.	When the E3 error displays, let cold water flow 10~20S then restart the appliance. If E3 still displays, check the water flow if too low. If not, check the thermostat to see if broken.
E4: Water inlet temperature sensor fault	Temperature sensor or system failure.	Check the water outlet temperature wires connection; if loosened, tighten it. If not, maybe the outlet temperature sensor fails. Replace it.
E5: Air pressure fault	Exhaust Blockage.	Remove obstruction, then restart the appliance.
	High winds blowing on exhaust.	Move or re-orient the coach exhaust is not facing high winds, then restart the appliance.
	Air switch or fan Fault.	Check the air switch or fan if broken.
E6: Temperature Surge alarm	Cold water surge in system.	Reduce toilet flushes and the number of cold water faucets opened during operation. Reduce temperature setting to reduce cold water mix ratio.
	Cold water mix ratio.	Check for shower head and outdoor faucet valves leaking cold water to the hot side.
	Insufficient water supply.	Confirm water tank is full or city water valve is fully open.
		Air in the water lines-continue to run all faucets, hot and cold, open until the air purged.
	Insufficient water flow.	Filter plugged- review "Cleaning and Maintenance" section of this manual.
		Low flow faucets - check that the minimum flow is 0.32gpm.
Temperature sensor or system fault.	Replace the outlet temperature or main PCB control board.	
E7: Solenoid valve fault	Solenoid valve or system fault.	Check the solenoid valve wires connection to see if it loosens or is broken.
E8: Wind speed over limit fault	During normal combustion, the fan speed exceeds the current load speed limit for five consecutive seconds	Check the fan air inlet,

Troubleshooting

- If you encounter a problem with the appliance, as the table below states, try the suggested solutions. If difficulties persist, please call the Ranein service or the dealer.
- Don't repair the appliance yourself; a certified service technician must perform repairs.

Probl	Potential cause	Solution
Hot water temperature	Gas supply is turned off or interrupted.	Check and/or turn on the gas supply.
	Gas tank is empty.	Refill/replace the gas tank.
	The appliance is switched off.	Switch on the appliance according to the instructions
	Water supply is turned off.	Open the water supply.
	The power supply to the appliance is switched off.	Switch on the power supply to the appliance.
Hot water takes longer to reach temperature	Defect in the appliance.	Refer to the error codes list.
	1. Coldwater mixing into the hot water side. 2. Higher elevation. 3. Incoming water temperature is abnormally low.	1. Check all valves, inside and outside, to ensure they are closed. Check the shower head valve to make sure it is not partially closed. 2. This is normal due to lesser oxygen levels - Contact Ranein service. 3. See "Water Control Valve" for adjustment.
Hot water temperature too low	Gas flow to the appliance is too low (gas inlet pressure 11in. WC).	1. Consult vehicle documentation to determine if gas supply is capable of providing the necessary volume of gas for the appliance. 2. Contact a service technician to verify a suitable gas installation.
	The volume flow of hot water is too high and/or the temperature of cold water reaching the appliance is too low.	1. Turn down the hot water at the tap or shower to reduce volume flow. Or mix more cold water in the faucet 2. Potentially retrofit a volume flow throttle into the water system. This must be performed only by a certified service technician.
	Too much lime scale in the appliance.	Decalcify your water heater. See "Cleaning and Maintenance" section.
Water escaping at pressure safety valve	Cold water mixing into Hot water side.	Check all valves, inside and outside, to ensure they are closed. Check the shower head valve to make sure it is not partially closed.
	Water pressure in water system too high.	1. Adjust the water pump pressure to a maximum of 65PSI. 2. A water pressure reducer must be used if the water system is connected to a central water supply higher than 65PSI (rural or urban connection). 3. Install a water pressure regulator at the freshwater supply.
Water leaking at the water inlet filter	Lime or dirt under the pressure relief valve seat.	1. Allow the appliance to cool, then slowly operate the relief valve by rotating its valve handle (knob), to flush the water system and attempt to force dirt or foreign matter out of the pressure relief valve seat. 2. Replace the pressure relief valve. This must be performed only by a certified service technician.
	Lime or dirt under the O-ring seats.	Clean the O-rings and their corresponding sealing surfaces with clean water.
Water heater stops working often and water is found on the drainage tray	The unit is over heating, and the pressure relief valve discharged periodically.	Contact ranein service.
The power status LED is off although an operating the mode was selected.	Power supply to the appliance is switched off.	Switch on the power supply to the appliance.
	Blown fuse.	Switch the standard 125V/10A fuse. Contact ranein service.