

# 9L DUAL BASKET AIR FRYER



**RATED POWER**  
2700W

**TIMER**  
1-60 min

**ADJUSTABLE  
TEMPERATURE**  
80°C-200°C

**BASKET  
CAPACITY**  
5.5L + 3.5L

**Thank you for purchasing this NETTA product.**

Please read the user manual carefully before operating this appliance.

We will update our instruction manuals if necessary.

For the most up-to-date user manual, please visit our official website: [www.nettadirect.com](http://www.nettadirect.com).

You can download a copy of up to date user manuals at any time in electronic format. We do not supply you with a paper-based user manual after each revision.

## Require a larger version of this Instruction Manual?

Please download electronically  
from our website and use PDF  
reader on your device to enlarge  
the text if needed.

[www.nettadirect.com](http://www.nettadirect.com)

## Safety and Warnings

### Intended Use

NETTA Design is for domestic and indoor use only. This product is not intended for use by people who have lack of experience and knowledge or have reduced ability, or sensory and mental capabilities.

### Regular Check-Ups

Ensure the power cable and plug are not damaged before plugging into a socket.

Check all the knobs are functioning correctly.

## General Warnings

Always follow basic precautions before using the electrical appliance:

1. Read all instructions.
2. Before use check that the wall outlet voltage corresponds to the one shown on the rating plate.
3. Do not operate any appliance with a damaged cord or plug, or after the appliance malfunctions or is dropped or damaged in any manner.
4. If the supply cord is damaged it must be replaced by the manufacturer, an authorized service agent or a qualified technician in order to avoid a hazard.
5. The use of accessories not recommended by the manufacturer as this may cause injuries.
6. Do not touch the hot surface. Use the handle or the buttons.
7. Do not use the appliance for anything other than its intended use.
8. Do not let the cord hang over any table or counter edges or touch any hot surfaces.
9. Do not place on or near hot gas, an electric burner or in a heated oven.

## General Warnings

10. Do not leave the appliance unsupervised when it is being operated.
11. Children should not play with the appliance.
12. The appliance must not be immersed in liquid.
13. Unplug from the outlet when not in use and before cleaning. Allow to cool down for 30 minutes before putting on or taking off parts, or before cleaning the appliance.
14. To prevent fires, do not place the appliance close to flammable materials such as curtains. Do not place anything above the appliance.
15. Make sure all paper, cardboard and plastic has been removed before frying food.
16. The appliance cannot be used for storing things, especially papers, cardboard or plastic.
17. The appliances are not intended to be operated by means of an external timer or separate remote-control system.
18. This appliance shall not be used by children of ages 0 to 8. This appliance can be used by children aged 8 years and older if they are continuously supervised. Cleaning and user maintenance shall not be performed by children. Keep the appliance and its cord out of reach from children under 8 years of age.
19. This appliance is intended to be used for household use only.
20. Only connect the appliance to an earthed wall socket. Always make sure that the plug is inserted into the wall socket properly
21. Do not place the appliance against a wall or against other appliances. Leave at least 10 cm free space on the back and sides and 10 cm free space above the appliance. Do not place anything on top of the appliance.
22. During hot air frying, hot steam is released through the air outlet openings. Keep your hands and face at a safe distance from the steam

and from the air outlet openings. Also be careful of hot steam and air when you remove the pan from the appliance. - The accessible surfaces may become hot during use.

23. Do not place the appliance on or near a hot gas stove or all kinds of electric stove and electric cooking plates, or in a heated oven

24. Extreme caution must be used when moving an appliance containing hot oil or other hot liquids.

25. Do not use appliance for other than intended use.

26. Always attach plug to appliance first, then plug cord in the wall outlet. To disconnect, turn any control to "off," then remove plug from wall outlet.

27. Always put the ingredients to be fried in the basket, to prevent it from coming into contact with the heating elements.

28. Do not cover the air inlet and the air outer openings while the appliance is operating.

29. Do not fill the pot with oil as this may cause a fire hazard.

30. Never touch the inside of the appliance while it is operating. The temperature of accessible surfaces may be high when the appliance is operating.

31. Do not plug in the appliance or operate the control panel with wet hands.

32. Ensure the appliance is placed on a horizontal, even and stable surface.

33. Immediately unplug the appliance if you see dark smoke coming out of the appliance. Wait for the smoke emission to stop before you remove the pot from the appliance.

34. Always unplug the appliance while not using.

35. Save these instructions.

# Assembling the Product

## Product Features (Fig.1):

1. Top cover
2. Screw plug
3. Upper shell
4. Lower shell
5. Base
6. Panel
7. Upper shell decorative panel
8. Left shelf
9. Left pot
10. Left drawer movement
11. Left drawer panel
12. Left drawer panel decorative panel
13. Left single-pot handle
14. Handle decorative panels
15. Handle decorative cover
16. Right single pot handle
17. Right drawer panel decorative panel
18. Right drawer panel
19. Right pot
20. Right shelf
21. Right air outlet
22. Left air outlet
23. Power cord

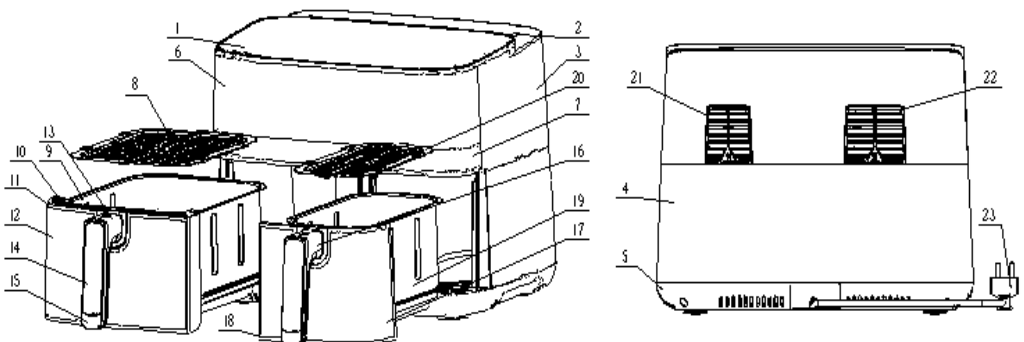

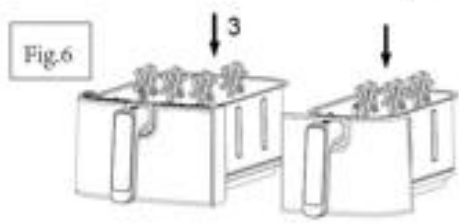
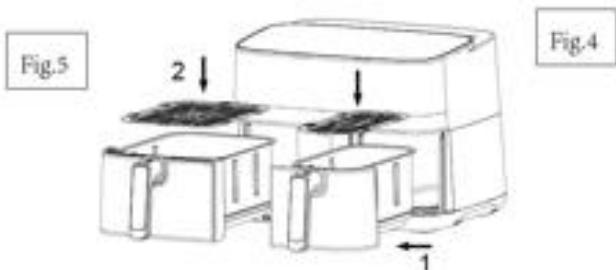

## Operating the Product

### Before first use:

1. Remove all packaging materials.
2. Remove any stickers or labels from the appliance.
3. Thoroughly clean the shelf and drawer with hot water, some washing-up liquid and a non-abrasive sponge.
4. Wipe inside and outside of the appliance with a damp cloth.

**Add 1tsp of oil to the drawer of your air fryer to get crispier results from your cooking.**

**Do not fill the drawer with oil or frying fat.**

**Note: When your air fryer is heated for the first time, it may emit slight smoke or odour. This is normal with many heating appliances and does not affect the safety of your appliance.**

### Preparing for use:

1. Place the appliance on a stable, horizontal and even surface.
2. Do not place the appliance on a non-heat-resistant surface.
3. Do not put anything on top of the appliance as the airflow will be disrupted and will affect the air frying results.

### Using the air fryer:

1. Connect the mains plug into an earthed wall socket.
2. Carefully pull the drawers out of the air fryer (Fig. 4).
3. Insert the shelves into the bottom of the drawers if you haven't done so already (Fig. 5). Ensure the raised handle is facing upward so you can pull the shelf out for cleaning when required.
4. Put the ingredients in the drawer (Fig. 6).
5. Slide the drawer back into the air fryer (Fig. 7).

**Ensure you carefully align the drawer with the guides in the body of the air fryer.**



6. Press the Power Key followed by the Drawer Key you want to select (1 (Left) or 2 (Right)). The selected Drawer Key will flash when selected.
7. Select your cooking pre-set and/or adjust the time and temperature to suit your requirements. Once set, you can either press the Power Key to start cooking or select the other Drawer Key to set the time/temperature for the other drawer.
8. If you wish to synchronise the finish time for both of the drawers, set your required time/temperature for both drawers followed by the Synchronisation End Key then press the Power Key. One drawer will start cooking and the other drawer will show 'HOLD' until the timers have synchronised.
9. Some ingredients require shaking halfway through the preparation time (see the 'settings' section later in this manual). To shake the ingredients, pull the drawer out of the appliance by the handle and shake it, then slide the drawer back into the air fryer.
10. When you hear the timer buzzer, the set cooking time has elapsed. Pull the drawer out of the appliance and check if the food has cooked to your requirements. If the food needs cooking for longer, simply slide the drawer back into the appliance and set the timer to a few extra minutes.
11. To remove the food, pull the drawer out of the air fryer and place it on a heat-resistant surface.

**The drawer and ingredients will be hot – only hold the drawer by the handle. Depending on the type of food in the air fryer, steam may escape from the drawer.**

12. Use kitchen tongs or utensils to transfer the food to a plate.

**Do not turn the drawer upside down as any excess oil that has collected on the bottom of the drawer will leak onto the ingredients.**

## Control Panel Instructions

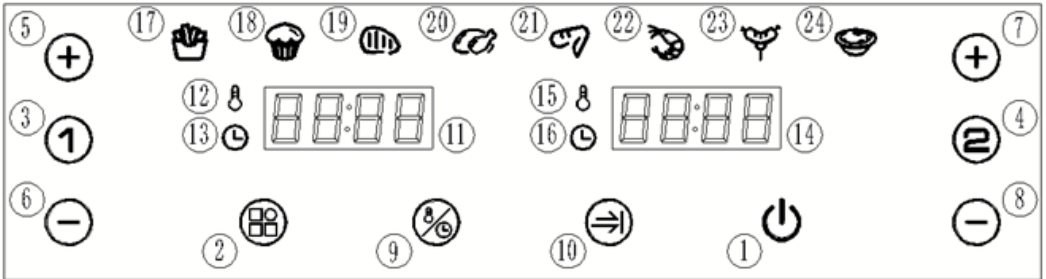

### 1. Power Key

Once the drawer has been properly placed in the main housing, the power light will be illuminated. Select the Power Key to put the machine into standby mode. Once you have selected your cooking settings, press the Power Key again to start the cooking process. To turn the appliance off entirely, hold the Power Key for 2 seconds. Note: During cooking, you can press the Power Key to control the pause and start of cooking.



### 2. Pre-Set Key

Selecting the Pre-Set Key enables you to scroll through the 8 popular food choices (indicator lights 17-24). Once selected, the pre-determined time and cooking temperature function begins.



### 3. Left Drawer Key

Touch the Left Drawer Key and it will start flashing. The display defaults to the first food item (fries), the 'fries' indicator light will flash and the display will show the default temperature and time cook fries.

When the temperature is displayed, the temperature indicator on the upper left of the display will remain on. When the time is displayed, the time indicator on the lower left of the display will remain on.

If you hold the Left Drawer Key for 2 seconds, you can cancel the selection of the left drawer and the product will enter standby mode.

2

#### 4. Right Drawer Key

Follows the same instructions as the Left Drawer Key – follow the above instruction to use this function.



#### 5 & 6. Temperature and Timer Control Keys for the Left Drawer

These keys enable you to increase or decrease the cooking temperature at 5°C increments. Hold the key down to rapidly change the temperature.

Follow the same instructions to change the cooking time (at one minute increments).



#### 7 & 8. Temperature and Timer Control Keys for the Right Drawer

Follow the same instructions as 5 & 6 above.



#### 9. Temperature/Timer Key

Touch the Temperature/Timer Key to make the display show the temperature or time. You can then adjust the temperature or time depending on your requirements.



#### 10. Synchronisation End Key

Touch the Synchronisation End Key and two recipes with different times can be ended at the same time.

**Indicator Light “11”** - Digital display for the left drawer

**Indicator Light “12”** - Temperature light for the left drawer

**Indicator Light “13”** - Timer light for the left drawer

**Indicator Light “14”** - Digital display for the right drawer

**Indicator Light “15”** - Temperature light for the right drawer

**Indicator Light “16”** - Timer light for the right drawer

**Indicator Light “17-24”** - Recipe indicator

# Operation Instructions

## 1. Boot Mode

Ensure that the drawer is correctly installed into the appliance and insert the plug into the socket. The appliance will have power, beep once and all the lights are lit for one second and the power icon will be illuminated.

## 2. Standby Mode

Press the Power Key. The Drawer 1 and Drawer 2 indicator will light up and stay on and the appliance will enter standby mode. When the appliance is in standby mode, you will have 3 minutes to start the operation before it goes back into Boot Mode.

## 3. Single Drawer Mode

3.1 Press Left Drawer Key (1) or Right Drawer Key (2) and the function key of the selected drawer will light up. The menu defaults to the first food item (fries), the 'fries' indicator light will flash and the display will show the default temperature and time to cook fries.

The time and temperature indicator lights will flash. Press and hold Left Drawer Key (1) or Right Drawer Key (2) for 2 seconds to cancel your selection. If both drawers are cancelled, the appliance will enter standby mode.

3.2 Press the Pre-Set Key to select the food you wish to cook. You can adjust the time and temperature to suit your requirements if needed by pressing the temperature and timer control key (5&6, 7&8). When adjusting the temperature, it will increase/decrease in 5°C increments. Hold the key down to rapidly change the temperature. The adjustable temperature range is 80°C-200°C. When adjusting the timer, it will increase/decrease in one minute increments. The timer range is 0-60 minutes. Hold the key down to rapidly change the time.

- 3.3 Once the timer and temperature have been set, touch the Power Key Icon and the appliance will start cooking the food. The display will show the remaining cooking time. The selected food pre-set will stay illuminated.
- 3.4 If you need to adjust the temperature or time during the cooking process, press the 'temperature/timer' key once and then press Temperature or Timer control keys (+ or -) to adjust to your requirements. The appliance will keep cooking during the adjustment process.
- 3.5 To pause cooking, press the Power Key during cooking and the appliance will stop cooking. If there is no operation within 3 minutes, the air fryer will automatically return to standby mode.
- 3.6 If you need to turn the appliance OFF during cooking, press the Power Key for 2 seconds and the air fryer will turn off. The display screen will show 'OFF' and the buzzer will beep.
- 3.7 After cooking, the screen displays 'OFF' and the buzzer will beep 5 times. The display screen will then turn off and the appliance will go into standby mode.
- 3.8 During cooking, if you remove the drawer, the display screen will show 'OPEN' and the appliance will pause. Once the drawer is reinserted into the air fryer, it will resume operation.

## **4. Dual Basket Mode**

### **4.1 Starting both of the Drawers**

- 4.1.1 Select one side of the appliance and set your desired pre-set/time/temperature. Then select the other side of the appliance and set your desired pre-set/time/temperature in the same way.
- 4.1.2 Press the Power Key and both drawers will start cooking. The indicator light for the Left Drawer (1) will flash once every 6 seconds. The indicator light for the Right Drawer (2) will also

flash once every 6 seconds. They will alternate at around a 3 second interval.

- 4.1.3 If you wish to start Left Drawer (1) first, you can do this by pressing the Power Key, setting the time/temperature for Left Drawer (1) and pressing the Power Key – Left Drawer (1) will start cooking. When required, press the Right Drawer Key (2), set the time/temperature and then press the Power Key to start cooking.
- 4.1.4 During the Dual Basket Mode, pressing the Temperature Key once will show the current temperature of each drawer on the left and right display screen. After 3 seconds, the display will switch back to the remaining time.

## **4.2 Adjusting the time/temperature during the Dual Basket Mode**

- 4.2.1 If you need to adjust the time/temperature of the Left Drawer (1) during the Dual Basket Mode, you can do this by pressing the Left Drawer Key (1) and then adjusting the temperature/timer as needed. If there is no operation within 10 seconds, the display screen will return to the timer countdown. Follow the same instructions to adjust the Right Drawer (2).
- 4.2.2 During the cooking process, you can adjust the recipe/time/temperature by pressing 1 or 2 followed by the Power Key. The Left Drawer (1) or Right Drawer (2) (depending on your selection) will pause cooking. You can now adjust the recipe/time/temperature to your requirements and then press the Power Key to resume cooking.
- 4.2.3 If the appliance is in pause mode, and there is no operation within 3 minutes, the drawer that is paused will enter standby mode.

## **4.3 Cancel the Cooking Process for One of the Drawers**

- 4.3.1 Press Left Drawer Key (1) or Right Drawer Key (2) followed by holding the Power Key for 2 seconds. The selected drawer will stop working, display 'OFF' and enter standby mode.

## **4.4 Removing a Drawer whilst Cooking**

- 4.4.1 During the cooking process, if one drawer is removed, the display will show 'OPEN' and the corresponding side will stop working and will resume once the drawer is reinserted. Removing one drawer will not affect the cooking of the other drawer.
- 4.4.2 When the drawer is removed in standby mode, the display will show 'OPEN'. At this time, the corresponding drawer cannot be operated.

## **4.5 Pausing both of the Drawers**

- 4.5.1. When in the Dual Basket Mode, press the Power Key once and both of the drawers will enter pause mode at the same time. Both of the displays will flash. Press the Power Key again to resume the cooking function.
- 4.5.2. If both drawers are paused at the same time, and there is no operation for 3 minutes, both drawers will stop working and enter standby mode.
- 4.5.3. During Dual Basket Mode, press the Power Key once and both drawers will enter pause mode. If you need to adjust the time/temperature, press Left Drawer Key (1) or Right Drawer Key (2) and then adjust the recipe/time/temperature to your requirements. Then press the Power Key to resume cooking mode for both drawers.
- 4.5.4. During Dual Basket Mode, press the Power Key once and both drawers will enter pause mode. Hold the Power Key again for 2 seconds and both drawers will stop working and both displays will show 'OFF'. The appliance will beep and then go into standby mode.

## **4.6 Turn off both of the Drawers**

- 4.6.1 During Dual Basket Mode, hold the Power Key for 2 seconds. Both drawers will stop working and both displays will show 'OFF'. The appliance will beep and then go into standby mode.
- 4.6.2 Once the timer runs out, both drawers will stop cooking and the display screens will show 'OFF'. The appliance will beep 5 times and then go into standby mode.

## **4.7 Synchronised End Function**

- 4.7.1 This function will only be available when you select two recipes with different cooking times in Dual Basket Mode.
- 4.7.2 Once you have selected your desired recipe/time/temperature, press the Synchronisation End Key and then press the Power Key to start cooking. The drawer with a shorter cooking time will display 'HOLD'. Once the extra time has passed, this drawer will start cooking.
- 4.7.3 During the cooking operation, if the time displayed on the 'HOLD' drawer is greater than the time displayed on the other side, exit the synchronisation end function and the Synchronisation End Key indicator light will turn off.
- 4.7.4 During the cooking operation, if you remove one of the drawers, the timer will pause for both drawers and the display will show 'HOLD'. Once you reinsert the drawer, the air fryer will continue to cook in synchronised mode.
- 4.7.5 If you remove the drawer that is cooking, the display will show 'OPEN' and that side will stop cooking. The 'HOLD' side will continue to show 'HOLD'. Re-insert the basket to continue cooking.



- 4.7.6 If you remove the 'HOLD' side basket, the display will show 'OPEN' but the other side will continue to cook. When re-inserting the 'HOLD' side basket, if the cooking time for the other side is less than the preset cooking time for the 'HOLD' side, the Synchronised End Function will stop and each side will keep working as per their preset cooking times.
- 4.7.7 When 'HOLD' mode ends and both sides are cooking, if you withdraw either basket, its display will show 'OPEN' and to will stop working. When the basket is re-inserted, the cooking time will match with the other side to ensure Synchronised End Function is still working.
- 4.7.8 If any side is paused during cooking, the Synchronised End Function will stop and the other side will continue to work as per its preset time/temperature.
- 4.7.9 If one side is on 'HOLD' and one side is cooking, pressing the Synchronisation End Key will stop the synchronisation and each side will continue to work as per its preset time/temperature.

## Settings

The table below will help you select the basic settings for certain food types. Please keep in mind that the suggested settings are indications. You may need to alter the settings depending on the size and shape of the food/ingredient you are cooking.

Tips:

- Smaller ingredients usually require a slightly shorter preparation time than larger ingredients.
- A large amount of food may require a longer cooking time (and vice versa).
- Shaking the drawer halfway through cooking will ensure that your food is cooked evenly.
- Adding a small amount of oil to the drawer when cooking chips/fries etc will ensure a crispier end result.
- The optimal amount of fries for this air fryer is 500g.
- You can place a baking tin or oven dish into this air fryer if you wish to bake a cake/quiche etc.
- If you wish to reheat food, set the temperature to 150°C and cook for 5-10 minutes.
- Add 3 minutes to the cooking time if you start cooking whilst the air fryer is cold.

## Cleaning, Maintenance and Storage

### Cleaning:

Clean the appliance after every use.

**Do not use metal kitchen utensils or abrasive cleaning materials to clean the product as this may damage the non-stick coating.**

1. Unplug the appliance from the wall socket and allow it to cool down.
2. Wipe the outside of the appliance with a damp cloth.
3. Clean the drawer with hot water, washing-up liquid and a non-abrasive sponge. You can use degreasing liquid to remove any remaining dirt.
4. If any dirt is stuck to the bottom of the drawer or shelf, fill the drawer with hot water and some washing-up liquid. Put the shelf into the drawer and let it soak for approximately 10 minutes.
5. Clean the inside of the appliance with hot water and a non-abrasive sponge.
6. Clean the heating element with a cleaning brush to remove any food residue.

### Storage:

1. Unplug the appliance and let it cool down.
2. Make sure all the parts are clean and dry.
3. Store the appliance away from heat sources or liquid.

## Troubleshooting

<b>Problem</b>	<b>Possible Cause</b>	<b>Solution</b>
The air fryer does not work.	The appliance is not plugged in.	Put the mains plug in an earthed wall socket.
	You have not set the timer.	Set the timer key to the required preparation time to switch on the appliance.
The food is not cooked properly.	There is too much food in the drawer.	Put smaller batches of ingredients in the drawer. Smaller batches are cooked more evenly.
	The set temperature is too low.	Set the temperature key to the required temperature setting.
	The preparation time is too short.	Set the timer to the required preparation time.
The ingredients are cooked unevenly in the air fryer.	Certain types of ingredients need to be shaken halfway through the preparation time.	Ingredients that lie on top of or across each other (e.g., fries) need to be shaken halfway through the preparation time.
Fried snacks are not crispy when they come out of the air fryer.	You used a type of snacks meant to be prepared in a traditional deep fryer.	Use oven snacks or lightly brush some oil onto the snacks for a crispier result.
I cannot slide the drawer into the appliance properly.	There are too many ingredients in the drawer.	Do not fill the drawer beyond the MAX indication.
White smoke comes out of the appliance.	You are preparing greasy ingredients.	When you fry greasy ingredients in the air fryer, a large amount of oil will leak into the drawer. The oil produces white smoke and the pot may heat up more than usual. This does not affect the appliance or the end result.
	The drawer still contains grease residues from previous use.	White smoke is caused by grease heating up in the drawer. Make sure you clean the drawer properly after each use.
Fresh fries are cooked unevenly in the air fryer.	You did not use the right potato type.	Use fresh potatoes and make sure they stay firm during frying.
	You did not rinse the potato sticks properly before you fried them.	Rinse the potato sticks properly to remove starch from the outside of the sticks.
Fresh fries are not crispy when they come out of the air fryer.	The crispiness of the fries depends on the amount of oil and water in the fries.	Make sure you dry the potato sticks properly before you add the oil.
		Cut the potato sticks smaller for a crispier result.
		Add slightly more oil for a crispier result.

## Spare Parts and Repairs

---

To order replacement parts, please go to [www.nettadirect.com/parts](http://www.nettadirect.com/parts).

You will need PDC information from your product, user manual or carton box. Alternatively, go to our website and use search bar to find the parts available.

You can also find this code on the [back of this user manual](#).

For our repair service, please contact our customer support with email on [support@nettadirect.com](mailto:support@nettadirect.com) they will provide with more details of repair service with NETTA.

## Disposal of Product

---

**IMPORTANT INFORMATION FOR CORRECT DISPOSAL OF THE PRODUCT IN ACCORDANCE WITH EC DIRECTIVE 2002/96/EC.**

### **DISPOSAL:**

Please dispose of this product responsibly. This item cannot be disposed of with general waste. Please contact your local council authority for more information on how to dispose this product. If this product is disposed of with general waste, it will end up in a landfill and will leak hazardous substances into the groundwater – effecting our food chain.



## Your Warranty

---

If you purchased with NETTADIRECT, or one of our authorised resellers, you will automatically enrol your warranty for 1 (ONE) year. You do not need to register for your warranty again. All warranties will be carried out to our terms and conditions including warranty conditions which you can find out from our website at [www.nettadirect.com](http://www.nettadirect.com).

## Copyrights

---

NETTA and its logo including images and contents in this manual and website is copyrighted. All intellectual property rights belong to NETTA owner CONSUMABLE DIRECT LIMITED.

ANY UNAUTHORISED USE, MODIFICATION or DISTRIBUTION of the NETTA logo, website image, and its contents (from website, manuals) will violate worldwide copyright, trademark and associated laws.

We reserve the right to proceed with lawsuits to anyone who is found breaching our copyrights policy. For more details, please check our website copyright policy for more information.

## Product Dependency Code (PDC)

---

Your PDC is below:

**PDC: AF-D5509AS**  
**SKU: 104036**

NETTA is a registered trademark of CONSUMABLE DIRECT LIMITED.  
Product Produced for CONSUMABLE DIRECT LIMITED M30 0QF U.K.