

# 4.2L MANUAL AIR FRYER

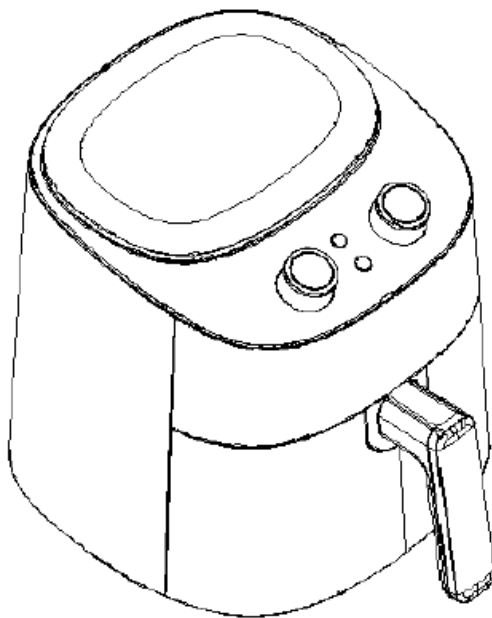

**RATED POWER**  
1300W

**TEMPERATURE**  
160-220°C

**TIMER**  
1-30 min

**Thank you for purchasing this NETTA product.**

Please read the user manual carefully before operating this appliance.

We will update our instruction manuals if necessary.

For the most up-to-date user manual, please visit our official website: [www.nettdirect.com](http://www.nettdirect.com).

You can download a copy of up-to-date user manuals at any time in electronic format. We do not supply you with a paper-based user manual after each revision.

**Require a larger version of this  
Instruction Manual?**

**Please download electronically  
from our website and use PDF  
reader on your device to enlarge  
the text if needed.**

**[www.nettdirect.com](http://www.nettdirect.com)**

## Safety and Warnings

### Intended Use

NETTA Design is for domestic and indoor use only. This product is not intended for use by people who have lack of experience and knowledge or have reduced ability, or sensory and mental capabilities.

### Regular Check-Ups

Ensure the power cable and plug are not damaged before plugging into a socket.

Check all the knobs are functioning correctly.

## General Warnings

Always follow basic precautions before using the electrical appliance:

1. Read all instructions.
2. Before use check that the wall outlet voltage corresponds to the one shown on the rating plate.
3. Do not operate any appliance with a damaged cord or plug, or after the appliance malfunctions or is dropped or damaged in any manner.
4. If the supply cord is damaged it must be replaced by the manufacturer, an authorized service agent or a qualified technician in order to avoid a hazard.
5. The use of accessories not recommended by the manufacturer as this may cause injuries.
6. Do not touch the hot surface. Use the handle or the buttons.
7. Do not use the appliance for anything other than its intended use.
8. Do not let the cord hang over any table or counter edges or touch any hot surfaces.
9. Do not place on or near hot gas, an electric burner or in a heated oven.

## General Warnings

10. Do not leave the appliance unsupervised when it is being operated.
11. Children should do not play with the appliance.
12. The appliance must not be immersed in liquid.
13. Unplug from the outlet when not in use and before cleaning. Allow to cool down before putting on or taking off parts, or before cleaning the appliance.
14. To prevent fires, do not place the appliance close to flammable materials such as curtains. Do not place anything above the appliance.
15. Make sure all paper, cardboard and plastic has been removed before frying food.
16. Place non-plastic coasters or placemats between the appliance and the worktop to avoid any permanent blemishes or stains.
17. The appliances are not intended to be operated by means of an external timer or separate remote-control system.
18. This appliance shall not be used by children of ages 0 to 16. This appliance can be used by children aged 16 years and older if they are continuously supervised. Cleaning and user maintenance shall not be performed by children.
19. This appliance is intended to be used in household and similar applications such as:
  - staff kitchen areas in shops, offices, and other working environments
  - farmhouses
  - by clients in hotels, motels, and other residential type environments
20. Only connect the appliance to an earthed wall socket. Always make sure that the plug is inserted into the wall socket properly

21. Do not place the appliance against a wall or against other appliances. Leave at least 10 cm free space on the back and sides and 10 cm free space above the appliance. Do not place anything on top of the appliance.

22. During hot air frying, hot steam is released through the air outlet openings. Keep your hands and face at a safe distance from the steam and from the air outlet openings. Also be careful of hot steam and air when you remove the pan from the appliance. The accessible surfaces may become hot during use.

23. Do not place the appliance on or near a hot gas stove or all kinds of electric stove and electric cooking plates, or in a heated oven

24. Save these instructions.

## Before Using for the First Time

- The air fryer is shipped with the frying drawer inside the body of the air fryer. Firmly grasp the handle of the drawer to remove the drawer from the appliance and place on a flat, clean work surface.
- Remove all packaging materials and labels from inside and outside of the air fryer. Ensure that there is no packaging underneath and around the frying drawer.
- Wash the frying drawer and shelf in hot, soapy water.
- **Do not immerse the air fryer body in water.**
- To clean the body of the air fryer, wipe with a damp cloth. Ensure all parts are dried thoroughly.
- The frying drawer is now ready for food to be added. You can insert the shelf into the bottom of the drawer for crispier results from your cooking.
- **During first use, the air fryer may emit a slight odour. This is normal.**

## Understanding the Product

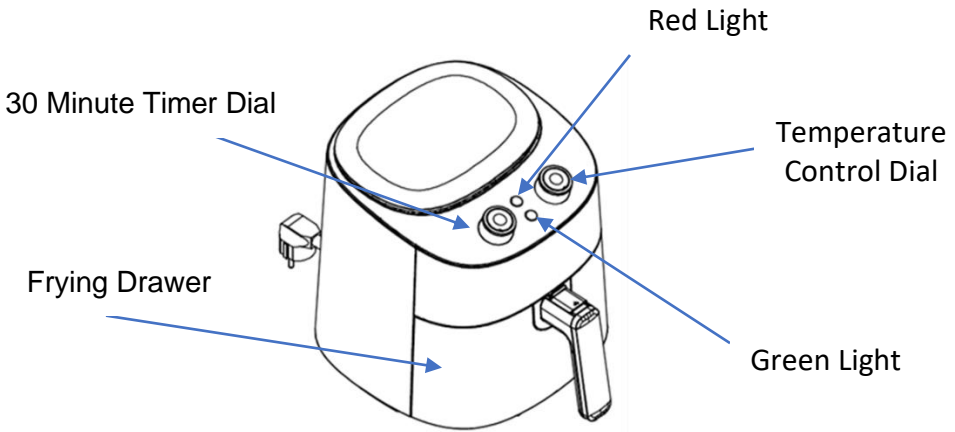

**Temperature Control Dial:** Select your desired air frying temperature from 160-220°C. Temperatures can be adjusted at any time.

**30 Minute Timer Dial:** Select your desired time and the air fryer will begin counting down. Once the set time reaches 0, the air fryer will beep and turn off. Both lights will also turn off.

**Green Light:** The green light will turn on once the set temperature is reached.

**Red Light:** Once the timer dial is set, the red light will turn on to indicate that the air fryer is cooking.

**Frying Drawer:** This is where your food goes. To ensure even cooking, remove the frying drawer half way through the cooking time and flip/shake the food in the drawer.

**Please note** that when you pull the drawer out of the air fryer body, the red power light and air fryer will pause until the drawer is re-inserted. The timer **will not** pause when the drawer is open.

**Important:** When air frying is finished, turn both the timer dial and temperature dial to MIN and 0 (off). Unplug when not in use.

## Operating the Product

- Place the air fryer on a flat, heat-resistant surface close to an electrical outlet.
- Firmly grasp the frying drawer handle to remove the drawer from the air fryer and place on a flat, clean surface.
- If the air fryer is cold, you may wish to preheat the air fryer. This can be done by setting your required temperature and adding 3-5 minutes onto the timer.
- Place food into the frying drawer. Do not overfill the frying drawer with food. To ensure proper cooking and air circulation, do not fill the frying drawer to more than half full.
- Push the drawer into the air fryer and ensure that it is completely closed.
- Plug the air fryer into the plug socket if you haven't already.
- To ensure even cooking, open the fryer drawer half way through the cooking time and flip/shake the food in the frying drawer. The air fryer will stop cooking until the frying drawer has been re-inserted.
- **The air fryer will not heat up if the timer dial has not been set.**
- **Be careful when flip/shaking the food in the frying drawer to avoid personal injury.**
- **Do not turn the food by shaking the whole machine.**
- **Take extra care when removing the drawer from the air fryer to avoid being scalded by hot steam.**
- **Beware of excess oil building up in the bottom of the drawer.**

- **The air fryer can be turned off at any time by turning the timer dial to 0.**
- Once the set time reaches 0, the air fryer will beep and turn off. Both lights will also turn off.
- Remove the frying drawer and shake your food to ensure it is cooked to your requirements. If additional frying is needed, adjust the temperature (if required) and add extra time onto the timer.
- When air frying is finished, remove the drawer from the machine and place on a flat, heat-resistant surface.
- Remove the food from the drawer and promptly re-insert the frying drawer back into the air fryer.
- When all air frying is completed, turn both the timer dial and temperature dial to MIN and 0 (off). Unplug when not in use.



## Cooking Tips

- Olive oil spray and vegetable oil works well for air frying.
- When cooking pre-packaged foods, the general rule is to lower the temperature by 10°C and reduce the cooking time by 30-50% depending on the food and amount. **Always check the temperature of your food before eating to ensure it is up to temperature.**
- Do not overfill the frying drawer with food. Never fill the frying drawer to more than 50% full.
- To achieve the best results, flip/shake the food halfway through the cooking period.
- To avoid excess smoke when cooking fatty foods (chicken wings, sausages, etc), you may need to empty fat from the drawer between batches.
- Always pat food dry before cooking to encourage browning and reduce excess smoke.
- Air fry small batches of freshly cooked breaded food. Press breading onto food to help it adhere. Arrange in the frying drawer so that food is not touching to allow air flow on all surfaces.
- The air fryer can be used to reheat food. Set the temperature to your requirement and check your food every few minutes.
- We recommend that you always use a food thermometer to ensure that your meat, poultry and fish are cooked thoroughly before eating.
- Frying in smaller batches will result in shorter cooking times and higher food quality.

# Cleaning, Maintenance and Storage

## Cleaning

- Unplug the air fryer and remove the drawer. Ensure the frying drawer has cooled down completely before cleaning.
- Wash the frying drawer in hot, soapy water. Do not use metal kitchen utensils or abrasive cleaners as this may damage the non-stick coating.
- The frying drawer is dishwasher safe. For best results, place it on the top rack of your dishwasher to clean.
- Wipe the air fryer body with a soft, non-abrasive damp cloth to clean.

## Storage

- Ensure the air fryer is unplugged and all parts are clean and dry before storing.
- Never store the air fryer while it is hot or wet.
- Store the air fryer either in its box or in a clean, dry place.

## Spare Parts and Repairs

---

To order replacement parts, please go to [www.nettadirect.com/parts](http://www.nettadirect.com/parts).

You will need PDC information from your product, user manual or carton box. Alternatively, go to our website and use search bar to find the parts available.

You can also find this code on the [back of this user manual](#).

For our repair service, please contact our customer support with email on [support@nettadirect.com](mailto:support@nettadirect.com) they will provide with more details of repair service with NETTA.

## Disposal of Product

---

**IMPORTANT INFORMATION FOR CORRECT DISPOSAL OF THE PRODUCT IN ACCORDANCE WITH EC DIRECTIVE 2002/96/EC.**

### **DISPOSAL:**

Please dispose of this product responsibly. This item cannot be disposed of with general waste. Please contact your local council authority for more information on how to dispose this product. If this product is disposed of with general waste, it will end up in a landfill and will leak hazardous substances into the groundwater – effecting our food chain.



## Your Warranty

---

If you purchased with NETTA DIRECT, or one of our authorised resellers, you will automatically enrol your warranty for 1 (ONE) year. You do not need to register again for your warranty. All warranties will be carried out to our terms and conditions including warranty conditions which you can find out from our website at [www.nettadirect.com](http://www.nettadirect.com).

## Copyrights

---

NETTA and its logo including images and contents in this manual and website is copyrighted. All intellectual property rights belong to NETTA owner CONSUMABLE DIRECT LIMITED.

ANY UNAUTHORISED USE, MODIFICATION or DISTRIBUTION of the NETTA logo, website image, and its contents (from website, manuals) will violate worldwide copyright, trademark and associated laws.

We reserve the right to proceed with lawsuits to anyone who is found breaching our copyrights policy. For more details, please check our website copyright policy for more information.

## Product Dependency Code (PDC)

---

Your PDC is below:

PDC: AF9001-GS  
SKU: 104026

NETTA is a registered trademark of CONSUMABLE DIRECT LIMITED.  
Product Produced for CONSUMABLE DIRECT LIMITED M30 0QF U.K.