

SEATTLE POTTERY SUPPLY KILNS

operator's manual



Seattle Pottery Supply Kilns

35 South Hanford Street • Seattle, Washington 98134

(206) 587-0570 • (800) 522-1975

FAX (888) 587-0373

www.seattlepotterysupply.com

TABLE OF CONTENTS

SAFETY

Installation	3
Operation	4
Maintenance	5

INSTALLATION

Placement	6
Clearance	6
Electrical	7
Assembly	7

LOADING THE KILN 9

FIRING

Test Firing	11
Digital Kilns - AutoFire or Bartlett	11
KilnSitter™	11
Bartlett V6CF Controller	14
QUICK START	15
Program the Controller	16
Programming for Cone Firings	18
Orton AutoFire 3000	22
Starting a Firing	23
Programming for Cone-Fire	24
KilnSitter™	26
Normal Firing Operation	31

KILN MAINTENANCE 34

WIRING DIAGRAMS 35

SAFETY

Kilns are safe and easy to use in schools, homes, studios and other spaces so long as one follows simple safety precautions. As with any electrical appliance have a licensed electrician ensure that the wiring and the outlet are correct for your specific kiln model. Always observe local building, fire, and safety codes.

Installation

- Follow all set up instructions.
- Place kiln at least 12 inches from any walls or flammable items.
- Reserve a clear empty zone extending 12 inches out from the kiln's steel jacket.
- Sufficient clearance should be left around the kiln to allow access for maintenance, servicing and free movement of air.
- Do not install kiln outside. Keep away from moisture and protect from weather.
- Install only on the stand provided with the kiln.
- Good housekeeping around kilns is essential and combustible materials should never be stored near the kiln or allowed to accumulate around it.
- Ventilation is important. Make sure that there is ventilation that is appropriate for the kiln and the space that the kiln is installed.
- Never store anything inside, under, or on the kiln.
- Never use an extension cord.
- The exterior steel skin of the kiln can become very hot - up to 320° F (160°C) in some cases- despite high-duty brick insulation - warning labels near the lid's handle and control boxes should be clearly visible.

**WARNING – HOT
DO NOT TOUCH!**

- Care should be taken, particularly where children, members of the public or potentially vulnerable people (such as those with learning difficulties or physical disabilities) are undergoing instruction or are able to gain access to the kiln. In these cases, a barrier or kiln cage should be used.
- Ventilation of your workspace is essential to provide a healthy working environment. A properly installed Orton VentMaster™ Kiln Vent will remove potentially harmful products of combustion.

Operation

- Read all information in the kiln manual before firing your kiln.
- Do not fire the kiln unattended.
- Keep children away from the kiln even when it is not in use.
- Electric kilns should only be used by operators who are familiar with safe working procedures (including proper use of controls and safety devices) and are capable of recognizing faults and coping with emergencies.
- During firing and cooling, the kiln's stainless steel jacket bands and lid handle will be hot. Do not touch the exterior of the kiln until it has cooled to room temperature.
- During firing, wear fire-rated gloves (Kevlar) to protect your skin when removing the prop brick and closing the lid.
- High voltage! Never touch heating elements with anything while the kiln is firing.
- Do not store or use flammable liquids or sprays in the same room as your kiln.
- Do not open kiln during a firing.
- Never lean anything against the outside or inside the kiln.
- Only start the kiln firing after the kiln has been loaded and the lid is closed.
- Keep the kiln's power cord out of traffic areas and keep kiln room tidy to prevent a tripping hazard.
- If looking into a hot kiln make sure to wear appropriate Infrared (IR) and ultraviolet (UV) eye protection, such as #3 welder's green safety glasses.

- Do not unplug or plug an electric kiln in unless the circuit is off. Before loading or unloading the kiln, turn all switches to OFF, or on digital units,
- Do not try to unload a kiln until the outside of the kiln is cool to the touch and the pieces can be easily touched by hand.
- Be careful when opening the kiln door while the kiln is heated. We recommend you use fire rated gloves to protect your skin and make sure clothing is kept well away from any kiln opening or hot kiln surface.
- Kiln lids may be quite heavy. Secure the lid open only with the lid brace provided.
- When loading or unloading a kiln use gloves to protect your hands from possible sharp edges on items coming out of the kiln.

Maintenance

- Inspect electrical connections and safety controls before each use.
- Never fire your kiln if it has a damaged plug, receptacle, or power cord.
- Always unplug your kiln before performing any maintenance to the kiln. This includes vacuuming, replacing elements, and any other maintenance on the kiln or area around the kiln.
- Only put clay items that are meant to be fired in a kiln. Make sure that clay and glaze are fired to the appropriate temperatures. Call the supplier the items were purchased from with any questions.

INSTALLATION

Placement

A kiln is hard-working appliance that needs adequate space to function effectively and safely. It gets very hot on its outside skin during firing and must have an 12" air space around it on all sides away from any adjacent surfaces and materials, shelving, and other kilns. Overhead open space should extend up to the ceiling and be clear of any obstructions, including shelving, draperies, cabinets, etc.

A bare concrete, tile, or brick floor is the best flooring surface for your kiln. If the kiln is installed over any other type of floor install a fire-retardant board, extending a minimum 12" beyond the kiln's exterior steel skin, under the kiln's stand to protect the floor from discoloration due to the heat from the kiln.

Locate your kiln along an exterior wall where installation of a motorized vent - like an Orton VentMaster™ - is more straightforward.

If your studio has a fire control sprinkler system, locate your kiln outside of a 10' (3m) radius below sprinkler heads.

Locate your kiln in an area free from flammable materials.

The kiln room must be ventilated so that the room does not get too hot or cold, as the kiln will not operate properly. Safe operating temperature range in the kiln room is between 32°F (0°C) and 100°F (37.8°C). Extremes outside of this range may damage electronic components.

Clearance

Reserve a generous 12" of clear space all around your kiln. Kiln shelves, posts, cones, stilts, and kiln wash may be conveniently located on shelving outside of this clear area.

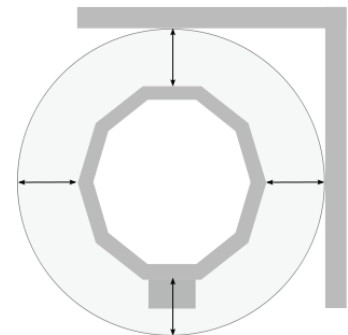

Electrical

Always observe local building, fire, and safety codes. Before setting up a kiln in any space have a licensed electrician evaluate all wiring for the kiln. Your new kiln must have the proper outlet and breaker to supply adequate voltage and amperage. Have your electrician compare your building's capacity and the electrical specifications for the kiln model you want. Also, confirm your measured on-site voltage and present this when ordering your kiln (outlets and service boxes are marked only with their ratings and not your local available voltage).

Be familiar with where the electrical service panel is and which specific breaker switch will shut off power to the kiln. Remember to turn off the power to the kiln when performing any maintenance.

Assembly

The kiln should be set up *only* on the stand that was supplied with the kiln. As you move the kiln into position make sure that the base is level on the stand. Use metal shims under the feet of the stand if needed to level. Do not place shims between the kiln's base and the stand as that could cause damage to the kiln. Adjust the position of the base and stand to provide an 12" clear space around your kiln. To move the kiln, never push the kiln as that will cause damage to the kiln's brick and possibly other components of the kiln. Center the base on the stand, level it, and then stack the kiln's rings onto the base. Align the kiln's electrical boxes and re-attach section brackets and back-braces if included. Specific installation instructions are provided with each kiln model.

Larger Seattle Pottery Supply™ Kilns models have hardwired connections in their top and bottom boxes. Follow the installation directions provided with your specific kiln model. Wiring diagrams for most Seattle Pottery Supply™ Kiln models are provided in the appendix of this manual.

Before using the kiln for the first time, disconnect from power and clean in interior by vacuuming with a soft bristle attachment. Apply kiln wash to the tops of the kilns shelves only. Do not apply kiln wash to the walls, lid or elements of the kiln.

The following accessories are included with the purchase of your New Seattle Pottery Supply Kiln:

- Peep Hole plugs for each hole in front of the kiln. (Oval kilns have hole in lid as well.) If you are looking in the kiln through one of the peep holes in the front be sure to use dark glasses to protect your eyes from the heat of the kiln. Peep holes will be hot when kiln is firing, use protective gloves if touching during a firing schedule.
- The Prop brick is a brick wedge used to prop the kiln's lid open in the beginning of firings. The Prop brick should only be used if the kiln is on the lowest setting, on a preheat cycle or cooling and under 300°F (149°C).

LOADING THE KILN

Balance the Load

When planning how to load your kiln, keep in mind that the center of the kiln is generally the hottest. Therefore, you will want to distribute the load with the larger, thicker pieces towards the middle and the smaller, thinner pieces towards the top and bottom. In addition, if half your load consists of small, heavy pieces and the other half is large, thin-walled pieces, don't group them all in one section. Mix them so there is a balance of each type throughout the kiln.

Allow the Kiln to Breathe

Many studios work with glazes that require oxygen to develop properly. Provide enough space between items to allow them to “breathe”. Using half shelves with a 1/4” space gap in the middle will also help increase the flow of oxygen within the kiln chamber, especially when used in combination with a vent system.

Allow for Proper Clearances

Kilns lose most of their heat from the lid and the base. Ideally, there should be at least two inches of space between the lid and the closest piece. The first shelf should be posted up one inch from the bottom slab.

Nothing directly under the Kiln Vent Holes

Holes drilled in the lids of the kiln that have AMACO® kiln vents allow air to be drawn into the kiln chamber. If a piece of ware is sitting directly under one of these holes, it could leave a spot in the glaze. If it is not possible to cap the load with a shelf, leave a five-inch radius on the shelf directly below each hole.

Load Slowly

Dropped ware on shelves may damage the inside of your kiln.

DO NOT set pieces directly on kiln floor

The first shelf should be 1" off the floor of the kiln. For best results, ware should not be placed within 1" of the elements. Large flat pieces like plates that demand the full width of the kiln should have their rims positioned between two elements.

DO NOT crowd the Kiln-Sitter® or Thermocouple

Keep shelves at least 1/4" from the sensing rod and ware at least 1/2" away. If your load should shift during firing there will be less danger of jamming the Kiln-Sitter® or having ware resting against the thermocouple causing inaccurate temperature readings or damage to the ware.

TEST FIRING

The first firing of a new kiln is considered important by many in order to ensure that the kiln is operating correctly and has been installed properly. The test firing also is to put a protective oxide layer on the elements and thermocouple. This done without any wares in the kiln that might give off fumes that contaminate the elements although the shelves and a witness cone should be in the kiln to test that the firing temperature is correct.

Digital Kilns - AutoFire or Bartlett

For the test firing load the kiln with the freshly kiln washed shelves with one of the shelves placed on 1 inch posts on the base of the kiln then stack the remaining shelves to ensure proper ventilation and air movement in the kiln. The witness cone should be placed on the middle of the shelf nearest the center of the kiln. Program the kiln to cone 04 matching the Self-Supporting Cone provided with the kiln. Following the instructions found in the programming section of this manual to program a Cone 04 firing a Medium Speed with No Hold and No Preheat.

KilnSitter™

Firing tests are made with the kiln empty. To expedite the process it is recommended that you use small Orton cones, which mature at a relatively low temperature, typically a cone 04. Follow the instructions on the use of KilnSitter™ found in the Appendix.

Review the Results

A properly bent cone indicates that the kiln is functioning properly and accurately. The tip of the cone will be level with the top of the cone's base when fired properly. The diagrams below will give you an idea of a properly fired, under fired and over-fired cone. Some variation from a proper bend is expected and can be compensated for with the cone-offset adjustment for each particular cone number based on test firings.

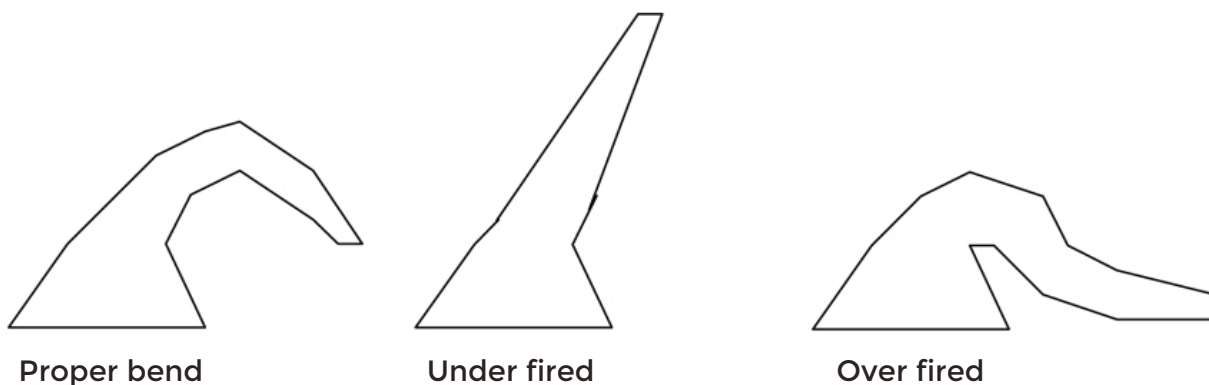

PROGRAMMING DIGITAL CONTROLLERS

All digital controllers contain electronic components, which are sensitive to static electricity. Before touching the controller disperse any static charge you may have by touching metal or a grounded object before touching the controller panel.

Always check the position of the thermocouple before starting a firing. The current temperature displayed on the controller is measured at the end of the thermocouple, which must be in the firing chamber about 1" to 1-1/2".

Always review the current program (by pressing Review Program) before firing to ensure the correct profile is programmed.

Ensure the kiln and the area around the kiln are clear of combustible material and has a clearance of 12" from walls.

When programming the kiln press the buttons firmly and slowly. Give the computer time to accept the information especially after pressing the Enter button. After Start is pressed 4-5 seconds will pass before the controller will begin the firing. The controller will cycle on and off at varying speeds depending on the program, amount of wares in kiln and the size of the kiln.

BARTLETT V6-CF

Controller Front Panel

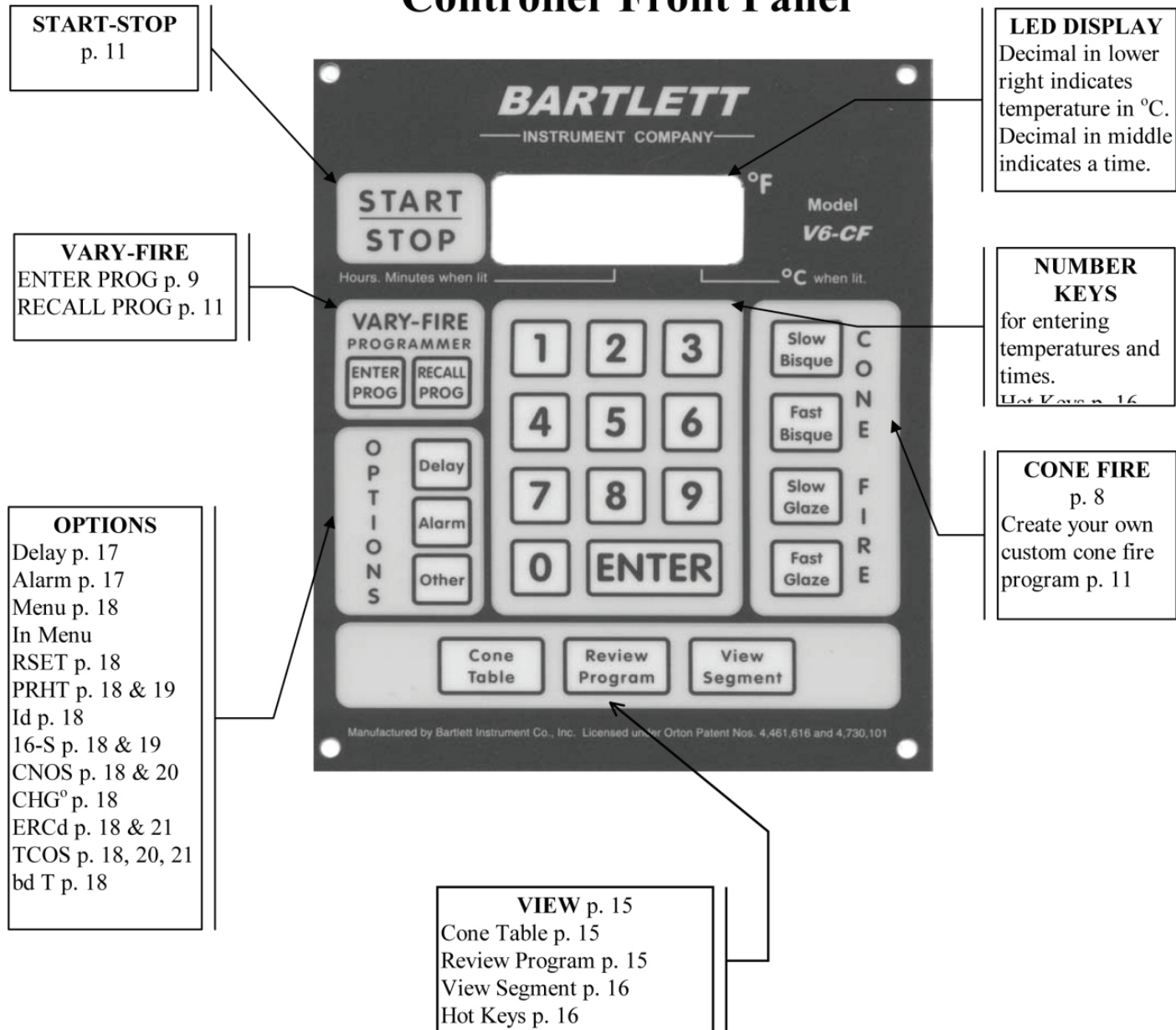

QUICK START

1. Read all precautions before using your controller.
 2. Apply power to the kiln/controller.
 3. Clear the display and get to the idle mode by pressing ENTER.
 4. Program the controller.
 5. Review the program before firing to ensure the correct program is ready to fire.
 6. Press Start. -On- will be displayed and then the kiln temperature. The relays and elements will be cycled on and off to regulate the temperature according to the program.
 7. At the end of the firing the controller will flash the current temperature, firing time, and CPLt. Press ENTER to return to the IdLE state.
- **IMPORTANT PROGRAMMING NOTE:** Before initiating a firing profile or performing any other function, the controller must be at IdLE. Pressing the ENTER key will clear the display of errors (E-) or FAIL.
 - In most cases when programming, you will choose an option, then press ENTER to accept the option.
 - With the display flashing IdLE alternating with the current temperature, you are ready to proceed with programming.
 - The CONE FIRE mode uses a patented method to achieve correct heat-work so it is ideal for firing ceramics. The advantage of using the CONE FIRE method is that a very complicated firing profile may be chosen with just a few key strokes. The CONE FIRE method helps protect against over and under firing by carefully tracking and controlling the temperature at the end of the firing as the cone temperature is approached. The final temperature is adjusted according to the final firing rate. For example, as the heating elements age and the heating rate slows, the final temperature will be adjusted downward to ensure the correct amount of heat-work.

- The VARY-FIRE mode can be used for ceramics, glass, jewelry, glazes, decals, etc. It allows you to create your own firing profiles which can be saved and used over and over.
- If there is a kiln sitter on the kiln it must be set according to the manufacturer's directions. Insert a cone in the sitter that is one or two cones hotter than the controller setting.

First Firing of the Kiln

The programmed cone number should match the cones provided with the kiln.

1. Apply power to the kiln/controller. The display will show WAIT, and then go to IdLE.
2. If the display shows PF press ENTER to proceed to the IdLE state.

Program the controller

Press	Fast Glaze	Display will show F-GL
Press	Enter	Display will show Cone/xxx
Press	0	Display will show 0
Press	4	Display will show 04
Press	Enter	Display will show HOLd/0.00
Press	Enter	Display returns to IdLE/temp

This example is for a Fast Glaze to cone 04 with no hold time at the end of firing which is a good firing schedule for the test firing.

It is a good idea to review the program every time before the kiln is fired.

Review the program before firing

Press **Review Program** key, the display will cycle through the following information:

Display Shows	Description
F-GL	Firing speed, fast glaze
PRHT/0.00	Shows zero preheat time
CONE/ 04	Programmed for cone 04
°F /1945	Top temperature for cone 04
CNOS/0	Shows 0°F cone adjustment
HOLD/0.00	Indicates zero hold at the top temperature
dELA/00.00	Indicates delay start of 0
ALRM/9999	Alarm is disabled
ERCD/on	Error detection is enabled
FIRE/xxxx	Shows the number of firings done with this controller

Starting Firings

Press START to begin the firing	The display will show -ON- then the current temperature. You will hear clicking when the relays cycle power to the elements to regulate the temperature. (The test firing will take around 6 to 7 hours, depending on the size of the kiln.)
End of firing CPLT	At the end of the firing, the display will flash between CPLT / Firing time / kiln temperature.
Press ENTER to return to IdLE	The display will now flash IdLE / kiln temperature. You may open the kiln when the temperature has cooled to 150°F.

Programming for Cone Firings

For ceramics, the pre-set Cone Fire Mode programs will likely satisfy your most common firings. The programs are written by Ceramic Engineers and have been created to properly fire your clay pieces through the different temperature stages of a firing. You simply input the target cone and firing speed and press start.

Although the Cone Fire Mode is incredibly easy to use, the software itself is extremely advanced. Cone Fire Mode uses complex algorithms to simulate the heatwork of a Pyrometric Cone. It automatically makes adjustments to the firing profile based on your kiln's performance. Cone values are based on heatwork and heatwork is a function of time and temperature. Therefore, if your kiln is firing slow due to a heavy load or aging elements, Cone Fire Mode automatically adjusts the peak temperature down so you get the perfect amount of heatwork. There are very few reasons not to use this mode of programming.

The firing speed is determined by the type of firing and thickness of the clay. The bisque firings include *water smoking* and carbon burn-out stages. The glaze speeds allow for faster firings. All 4 speeds will calculate the firing rate at the end of a firing and adjust the final temperature for correct heat-work. Follow these few steps to enter a cone fire program.

Press	Slow Bisque	Display shows S-bC	The slow bisque speed is used for thicker hand thrown ware. The slow speed gives extra time for release of water and carbon burn-out. Typical firing times range from 13-17 hours depending on the cone #. Most pieces need a preheat stage.
	OR Fast Bisque	Display shows F-bc	The fast bisque speed is for thinner ware that requires less time for water smoking and carbon burn-out. Firing time is 9 - 11 hours, typically, and depends on the cone number.
	OR Slow Glaze	Display shows S-GL	Slow glaze is used for firing glaze on thicker ware or for bisquing very thin ware. Typical firing time is 6-8 hours depending on the cone number.
	OR Fast Glaze	Display shows F-GL	Fast glaze is the fastest speed and is used for glaze firing on thin ware, china paint firings, and decal firings. Firing times range from 4 to 5 hours
Press	ENTER	Display shows CONE/xxx	The displayed firing speed was accepted and now the controller is waiting for the cone number to be entered. The x's represent the cone number last selected.
Press	Number keys for cone number	Display shows xxx	Use the number keys to display a new cone number. Remember, cone numbers starting with a 0 are lower temperature than cone numbers not starting with a 0. For example, don't mistake a cone 6 for a cone 06!
Press	ENTER	Display shows HOLD/0.00	The displayed cone number was accepted and now the controller is waiting for the hold time at the top temperature to be entered. Usually this value is left at 0. If a time is entered the hours are to the left of the decimal and the minutes to the right.
Press	ENTER	Programming complete Display is back to Idle	Zero hold was accepted and programming is complete.

NOTE: A preheat segment for drying (candling) ware can be added to any cone fire program.

Use the **Slow Bisque** program with a preheat segment for all bisque firings.

PRHT shows in the menu only when a cone fire is programmed. Preheat is used with the CONE FIRE Mode only. When Preheat is selected, the temperature ramps up at 60°F/hour (33°C/hr) to 200°F (93°C) and then holds at 200°F (93°C) for the amount of time programmed. Preheat is automatically set to zero during cone fire programming and at the end of each firing. Therefore, if a preheat stage is desired, it must be reprogrammed for each firing and be the last item programmed before START is pressed.

Step	Press	Display	Comment
1	Menu	PrHt	If PrHt does not show on the display, even after cycling through all the options it means that ConeFire mode has not been selected. Exit the menu and select a Cone Fire speed, then return to the Menu to set Preheat.
2	ENTER	Alternately flashing: Hld & 00.00	Preheat has been selected; enter the time you want to hold the temperature at 200°F (for example, 4 hours)
3	4, 0, 0	04.00	Displays the selected time of 2 hours. Numbers to left of decimal point are hours, to the right are minutes. If you type a wrong number, press zero 4 times, then enter the correct number.
4	ENTER	Display returns to current temperature and IdLE	Accepts the 4 hour preheat time. The current temperature then flashes in the display.

Remember the controller must be at IdLE to program a Preheat.

End of Firing – CPLT

At the end of the firing, the display will flash between CPLT / Firing time / kiln temperature

Press **ENTER** to return to IdLE - The display will now flash IdLE / kiln temperature.

You may open the kiln when the temperature has cooled to 150°F.

Review the Results

FINAL TEMPERATURE REACHED at the end of a cone fire program:

When the display is at IdLE, pressing Review Program will show the heat-work adjusted temperature that was reached. The temperature is displayed after °F in review program. This temperature will remain until the controller is reprogrammed. Record this temperature in your log after each cone firing.

After a firing record the firing time, and load size. In your log keep any repair information. If cones are placed in the kiln, record the amount of bending that took place.

A properly bent cone indicates that the kiln is functioning properly and accurately. The tip of the cone will be level with the top of the cone's base when fired properly. The diagrams below will give you an idea of a properly fired, under fired and over-fired cone. Some variation from a proper bend is expected and can be compensated for with the cone-offset adjustment for each particular cone number based on test firings.

NOTE - An error code (E-) in the display indicates an abnormal end to a firing. See the Error code section in the supplemental Bartlett Manual to help determine the reason for the error code.

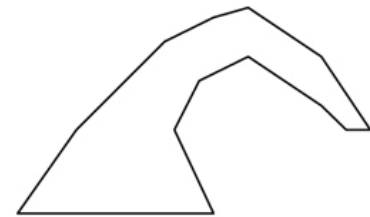

Proper bend

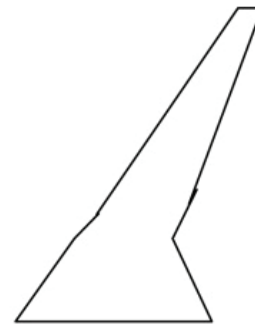

Under fired



Over fired

ORTON AUTOFIRE 3000

Firing Methods and Features

- **Cone-Fire method:** Select a preset program for a specific cone number from Cone 022 to Cone 12. These programs are designed specifically for ceramic firings.
- **User Program method:** Create 4 custom firing schedules with unique heating and cooling rates, target temperatures and hold times. This method can be used for ceramics, heat treating, glass fusing, enameling or jewelry applications.
- **Preheat** - Use with Cone-Fire mode to slowly dry ware and hold the kiln at 200°F (93°C) to remove moisture.
- **Speed adjustments** - Use with Cone-fire mode to speed up or slow down a firing in order to adjust for load size or thick pieces of ware.
- **Delay start** - Use with either mode to delay start the kiln up to 100 hours (99hr.59min.)
- **Set-Point Control** - User Program option to hold kiln at temperature indefinitely.
- **Full On / Full Off** - User Program option to heat kiln as fast as possible or to cool as fast as possible.
- **Add Time** - Add additional hold time to firings already in progress.
- **Back** - Correct or make changes while programming without having to start over.
- **Program edit** - User Program option to change target temperatures and hold times during the firing without having to stop and restart the controller.



When the Controller is first turned on

The controller runs a brief self-diagnostic test. The display will light up and the audible alarm sounds temporarily. In 5 seconds or less, the display will alternate between the kiln temperature and **IdLE**. **IdLE** is the mode where the controller is not actively firing the kiln or being programmed for a firing.

Starting a Firing

The display shows **STRT** for 5 seconds when the firing begins. **STRT** is the 'Start' message. The display will show kiln temperature throughout the firing. The temperature display will alternate with alarm messages if any alarms occur. If the controller is programmed to hold at a specific temperature, the remaining Hold Time will alternate with the temperature as well.

Ending a Firing

When the controller completes the firing, the display alternates 4 messages: **CPLT** (Firing Complete); Firing Time (**hrs.mins**); Final Firing Temperature and Current Kiln Temperature. Press any key to return to **IdLE**. If you stop the firing before completion with the **Stop** key, the display will indicate **AbRT** (abort) in place of **CPLT**. Press **Stop** again to return to **IdLE**

Entering values

Whenever a change is made from the keypad, you must press the **Enter/Start** key to load the changes. If the key is not pressed, the controller will simply wait for your next selection. Pressing the **Enter/Start** key will advance you to the next option if you are setting up a program or changing settings.

Note: *If you are programming the controller and no keys are pressed for 1 minute, the controller will return to the **IdLE** mode.*

Programming for Cone-Fire

During programming, default values may appear in the display. If the controller was previously programmed, the last settings will appear.

1. Press the **#1/ConeFire** key. **CONE** shows in display alternating with the last Cone selection value.
2. Using the numeric keypad, select the desired Cone number. For Example: you would press the **#0** key and the **#6** key for a Cone 06 firing. Then press **Enter**.
3. **SPd** shows in the display indicating the Speed setting - Press the **#1** key to select 'Fast', **#2** key to select "Standard" or the **#3** key to select 'Slow'. Then press **Enter**.
4. **PRHT** shows in the display indicating the optional preheat time. Preheat will heat the kiln at the rate of 60oF(33oC)/hr up to 200°F(93oC), **PRHT** will be alternating with a Time value. Using the numeric keypad, enter a time for the kiln to hold at 200oF. Time is entered in (Hours.Minutes). If no preheat is needed, program zero hours and zero minutes (00.00). Then press **Enter**.

*After the kiln firing has started and the Preheat temperature is reached, the Cone Fire program will begin automatically once the Preheat hold time has expired. You can Skip out of the Preheat ramp or hold period at any time by pressing the **#9/Skip** key and **Enter**.*

5. **HOLD** shows in the display indicating the optional Hold time at the end of the firing, **HOLD** will be alternating with a Time value. Using the numeric keypad, select a time for the kiln to hold at the top cone temperature. Enter time as (Hours.Minutes). If no Hold is needed, program zero hours and zero minutes (00.00). Then press **Enter**.
6. **COOL** shows in the display indicating the optional Cooling ramp at the end of the firing, **COOL** will be alternating with a rate value. Using the numeric keypad, Enter a cooling rate for the kiln to cool to 392°F(200°C). The maximum cooling rate is limited to 180°F(100°C)/hour. If no controlled cooling is needed, program the rate value as zero. Then press **Enter**.

*The controller will return to **IdLE**. The programmed firing schedule is automatically stored and ready to begin the firing. To verify the program, you can press the **#6/Review** key at any time.*

7. If no advanced features are desired - Press **Enter/Start** to begin the firing.

Display Lights

The controller uses (4) numerical displays and 3 indicator lights. The 3 lights tell when the controller is turning on the relays to power the heating elements. For a single zone controller, all 3 lights turn on and off together unless the *Balance* option has been adjusted. For multi zone controllers, each light is independent. The top light represents the top zone, the middle light represents the middle zone and the bottom light represents the bottom zone.

Two of the four decimal points on the display are also used as indicators. The decimal point on the far right is used to indicate if the controller is displaying temperature in degrees Fahrenheit (°F) or Centigrade (°C). If this decimal point is lit, the controller is set to display temperatures in °C.

The center decimal point (between the second and third digit) lights whenever the display is showing a time value. The decimal point separates Hours (on the left) from Minutes (on the right)

KILNSITTER™

The KILNSITTER™ is designed to stop the firing process once your kiln has achieved the desired amount of heat work. Heat work is defined as the combined effect of both time and temperature related to the firing of ceramic ware. Utilizing a small standard Orton cone or bar, the KILNSITTER™ switch will disengage and break the power supply to the kilns heating elements when the cone reaches its equivalent heat work temperature.

The KILNSITTER™ requires very little maintenance but may need an occasional adjustment. With proper care and maintenance your KILNSITTER™ should provide you with many years of trouble free service. Replacement parts such as the tube assembly, cone supports or sensing rod are available to extend the operating life of your KILNSITTER™. Frequency of replacement depends on the type of firing, type of clay used, proper venting and the moisture content of the pieces being fired.

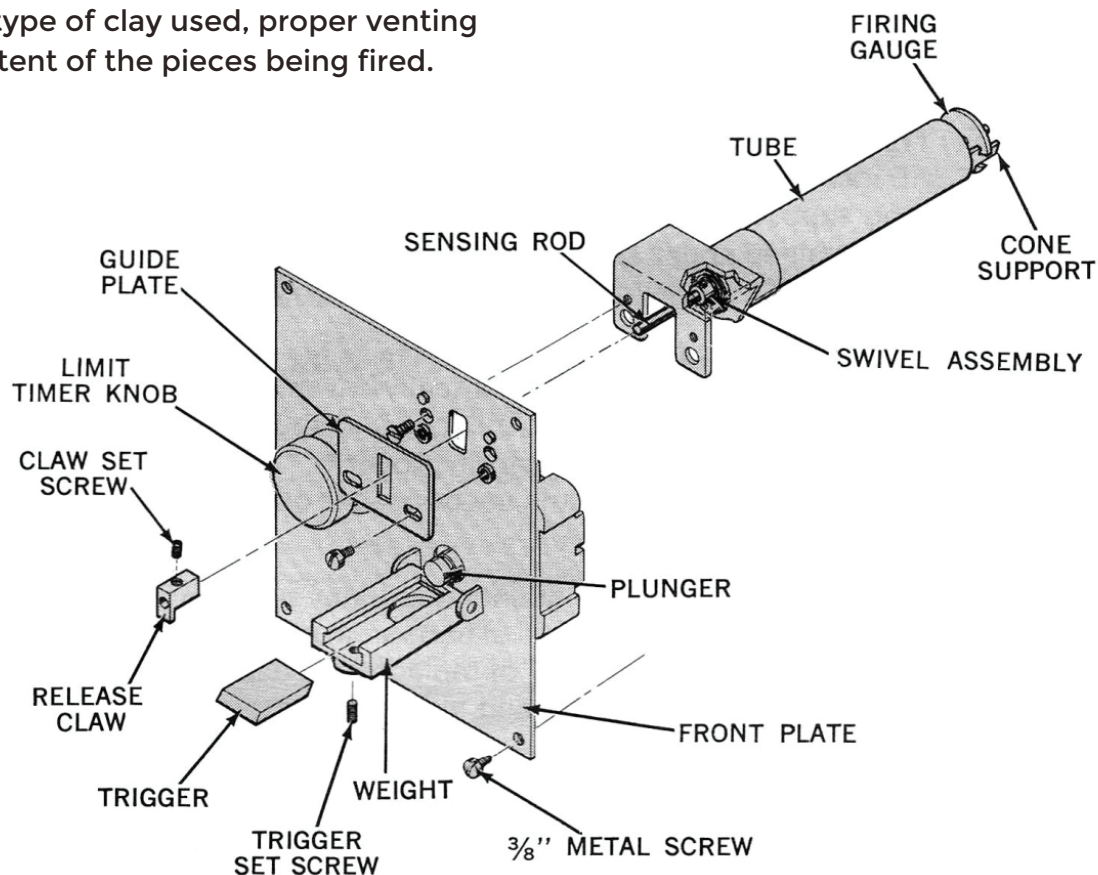

Although your KILNSITTER™® was installed by your kiln manufacturer it may require adjustment prior to firing your kiln. Please follow your kiln manufacturer's instructions for the initial firing of your kiln. The instructions for adjusting your KILNSITTER™® found within this manual will guide you through the adjustment process. To insure that your KILNSITTER™® is properly adjusted, follow the instructions on the following pages and conduct a test firing of your kiln with the KILNSITTER™® before you do anything else. For the test firing, load the kiln with kiln shelves and posts only. Do not attempt to fire any clayware at this time.

MAINTENANCE OF YOUR KILNSITTER™® (KilnSitter)

Your KILNSITTER™® is manufactured from the finest materials available - selected for strength, durability and resistance to heat and corrosion. However, during the firing operation, moisture and corrosive gasses are created which can, in time, alter the normal shut off function. Following proper maintenance procedures and operating recommendations which will keep your KILNSITTER™® doing its job. Careful attention to these instructions will reward you with trouble free firing

NEVER USE LUBRICANTS OF ANY KIND ON THE KILNSITTER™®

Periodic Adjustments

The KILNSITTER™® may get out of adjustment during use and we recommend you repeat an adjustment check every 30 firings.

Adjustment/replacement Procedure

Conduct this procedure whenever a new device is used for the first time or after replacing a tube assembly.

1. Turn all switches to “off” and disconnect kiln from the power supply. (Unplug the kiln from the power outlet).
2. Install the firing gauge.
Normally the firing gauge is in position when your kiln is shipped from the factory (held by a rubber band at the end of the KILNSITTER™ tube.) If it has been removed, it should now be replaced over the sensing rod and cone supports, as shown in Figure 1.

CAUTION: Remove firing gauge before operating kiln.

3. Check the position of holding claw and trigger weight.
First, check your kiln with a level to make sure it is not set on an uneven floor, if it is not level, the weight may not fall when released.

WARNING: Do not fire your kiln over or near FLAMMABLE material (i.e. wood floor, carpeting, etc.)

With the firing gauge in position, swing the weight up against the guide plate. Push the claw down (against the slight play in the swivel/pivot assembly) and check for a 1/16th inch spacing between the inside tip of the claw and the face of the trigger as shown in Figure 2. The set screw on top of the claw may be loosened if the adjustment of the claw position is necessary. The claw should be flush with the end of the sensing rod. Retighten the set screw firmly. The height of the trigger can be adjusted by loosening the set screw as seen in figure 3. The setscrew must be firmly tightened or the force of repeated falling of the weight may cause the trigger to creep out of adjustment.



Figure 1
Firing Gauge

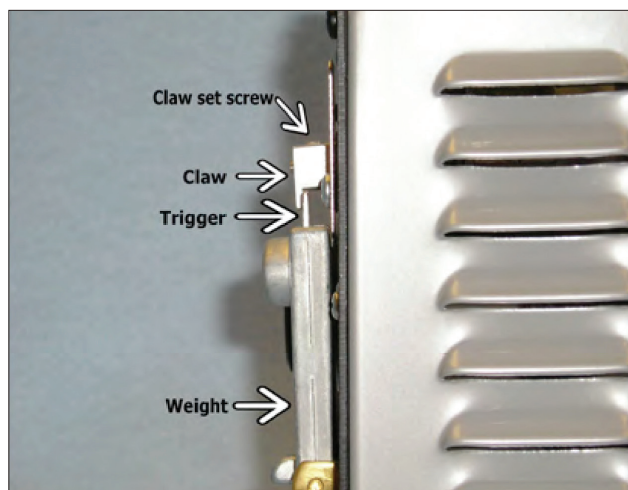

Figure 2



Figure 3

When the weight swings forward, the trigger should just clear the underside tip of the claw.

4. Verify free travel of sensing rod.

THE FIRING GAUGE SHOULD NOW BE REMOVED BUT KEPT FOR FUTURE PERIODIC ADJUSTMENTS. The sensing rod is now free to travel vertically within the tube cavity. It should travel freely in the center of the cavity without touching the sides at any point. If necessary, the sensing rod may be centered by loosening the guide plate screws in front of the KILNSITTER™ and moving the guide plate right or left as required. After making your adjustments, be sure the guide plate screws are firmly tightened. When these adjustments have been made, you are ready to test fire.

Venting the Kiln

It is recommended to use a vent for all kiln firings. Venting will reduce deterioration of the kiln's metal parts and increase the life of the tube assembly. In the event that no vent is in use, the top peephole should be left open for the entire firing period. For complete information on kiln ventilation call Seattle Pottery Supply.

Care of the Cone Supports

It is important that excess kiln wash not be allowed to accumulate on the supports. We recommend they be cleaned after every firing with a small wire brush. In the event the kiln wash or cone glaze cannot be removed, rotate the supports to the clean side or replace them. We suggest two pair of supports be available. This allows you to prepare a clean pair while the other pair is being used in the firing.

Care of the Swivel/Pivot (Tube Assembly)

The swivel/pivot of the tube assembly is the most sensitive part of the AUTO- CONE® and can become corroded and contaminated during normal firing. This can cause sluggish movement of the sensing rod and alter the shut off of the KILNSITTER™. We recommend, as good insurance against a mishap, that the guide plate be removed and the swivel/pivot of the tube assembly be examined every 6 to 12 months. The frequency of inspection depends on the type of firing, clay composition and moisture content, and humidity in the area. Evidence of contamination or sluggish movement would indicate the need for immediate replacement of the tube assembly.

Sensing Rod

Continued operation at high-fire temperatures will eventually cause the end of the rod to deteriorate or bend. This will, in turn, affect the adjustment of the trigger and claw. If this occurs, the rod must be replaced.

Operational Temperature

The KILNSITTER™ is engineered to withstand kiln temperature up to and including Cone 8. Temperatures higher than this limit will reduce the normal lifetime of the cone supports and sensing rod.

NORMAL FIRING OPERATION

It is the responsibility of the KILNSITTER™ user to become familiar with the proper operation and adjustment of the KILNSITTER™. If the simple steps and precautions, outlined in this manual, are followed with care, it will serve you as a valuable and reliable instrument for greater success and enjoyment in your ceramic firing. When you have assured that the KILNSITTER™ is in proper adjustment, by test firing, as described in that section, you are ready for normal firing operation.

1. Check the sensing rod

Before each firing check the sensing rod for free and centered travel. In spite of precautions, the swivel/pivot of the tube assembly can become corroded or contaminated and alter the normal shut off. If the sensing rod moves sluggishly, does not fall freely or you have inconsistent firings, immediately replace the tube assembly.

2. Start with all the kiln switches in the off position.

Electrical contacts in the KILNSITTER™ switch will last longer if kiln switches are off before engaging the KILNSITTER™.

3. Apply kiln wash

Apply a THIN coat of Hi-Fire kiln wash to the cone supports and sensing rod where they will come in contact with the cone. Allow the kiln wash to dry thoroughly. We suggest two pair of supports be available. This allows you to prepare a clean pair while the other pair is being used in the firing.

4. Stack ware in the kiln

When loading your kiln, care should be taken to keep the KILNSITTER™ tube, cone supports, and cone or bar visible from above at all times. If the tube is covered from view, the cone or bar could accidentally be dislodged from its proper position without being noticed and cause a malfunction of the KILNSITTER™ shutoff. Shelves and ware should be positioned at least an inch above or below the KILNSITTER™ tube so that the normal shut-off function will not be obstructed.

5. Raise the weight up against the guide plate.

6. **Press the claw down lightly until it hooks over the trigger and holds it in place.**

7. **Insert the cone (Small size cones or bars are used on KILNSITTER™®).**

While holding the claw down over the trigger, carefully place the cone or bar, selected for your firing, flat on the metal cone supports with the inside edge of the number circle even with the outside edge of the cone supports. See Figure 8. The cone or bar should be against the metal step with the center of the cone or bar parallel with the end of the tube. Consistent placement of the cone or bar in this manner will lead to consistent firing control. The cone or bar now holds the claw engaged so that the weight is supported and your hands are free.

8. **Check the position of the cone or bar.**

As a last step before closing the kiln, always check to see that the cone or bar is in its proper position and free of obstructions. **AN IMPROPERLY PLACED CONE OR BAR COULD CAUSE AN OVERFIRING AND DAMAGE YOUR KILN AND WARE.**

9. **Close the kiln.** All switches are off at this point.

10. **Set the limit timer knob.**

The timing knob will not allow the plunger assembly to engage when in the OFF position. Always set the timer prior to switch engagement (pushing in the plunger.)

How to use the Limit Timer

The limit timer is a safety shut-off device to protect your kiln from over-firing in case the KILNSITTER™® fails, through some malfunction, to shut off the kiln when the pyrometric cone or bar has matured. The numbers on the limit timer control knob indicate 20-hours of firing time. If your firing requires a longer period, the knob may be reset during firing for this additional time. Since the function of the limit timer is to override the actual firing time, it should always be set for a longer period than the estimated firing time. After you have become familiar with the firing of your particular kiln, you can set the limit time as low as 1/4-hour longer than the estimated firing time. Until you have reached that degree of familiarity, it is safer to set the limit timer 1/2-hour longer than the estimated firing time. The limit timer may also be used as a timing device to aid you while you are learning to estimate firing times. For example, if the timer knob is set at "7" before firing, and the indicator is on "1" when firing is completed, you know that the elapsed time was 6 hours.

Caution: *The timing knob should never be set beyond 20-hours. If the timing motor should be inoperative, such action could jam the switch assembly, possibly causing an over-firing.*

11. Venting

Venting of the kiln for the entire firing period will add years of life to your KILNSITTER™ porcelain tube assembly. Use of the Orton Vent Master kiln vent will also help increase the element life and reduce metal degradation. If you do not have a vented kiln, you should leave the lid open 1 inch and remove the top peephole. After the inside of the kiln begins to glow a dull red, close the lid.

12. Insert a finger into the hole in the trigger weight and push firmly in on the plunger until it locks.

13. Weight Clearance.

The area outside the kiln should be clear of obstructions so the free fall of the weight is not impeded.

14. Fire the kiln by using the regular kiln switches, as instructed by the manufacturer.

DO NOT LEAVE THE KILN UNATTENDED BEYOND THE ESTIMATED FIRING TIME. An uncontrollable accident, such as greenware falling against the end of the KILNSITTER™ porcelain tube, may cause an over-firing, which could damage your kiln. Should this occur, the operator should be in attendance to manually shut off the kiln.

KILN MAINTENANCE

Keeping up with the kiln maintenance is important for the kiln to run safely, efficiently, pieces to come out correct and to extend the life of the kiln. With most of the preventative upkeep being simple and quick these things should be done routinely.

It is important that before any work is done on a kiln with a manual controller that all of the switches are turned off and the kiln is unplugged. Leave Digital kilns plugged in when vacuuming to ground any static charges that may occur at the nozzle tip of the vacuum. Try to keep the vacuum away from the touch pad area.

The interior of the kiln should be vacuumed between each use, removing bits of loose dust and other materials that may accumulate in the kiln. Dust and debris in a kiln can settle on glazed wares and ruin them by leaving little dark spots in the glaze.

Use a soft bristle attachment when vacuuming the kiln as to not cause any damage to the firebrick or elements. When vacuuming take care around the elements as they are brittle and can be damaged by being moved.

Don't forget the maintenance of the kiln shelves. Maintain a coating of kiln wash on the tops, touching up as it flakes off and remove any glaze drips that will re-melt and damage the next firing.

Remember when removing any of the glaze chips to take proper safety precautions due to the process of cleaning creates flying debris.

Visually inspect the interior of the kiln before firing, check for glaze spots that may have happened. If found glaze spots should be removed when the kiln is unplugged with a flat bladed screwdriver if the spot is not too large or not near an element. If glaze spots are near an element or large call for assistance as these glaze spots will re-melt in the next firing and only cause further damage.

Examine plug and wall receptacle for any sign of excessive heat.

Replace both plug and receptacle if necessary.

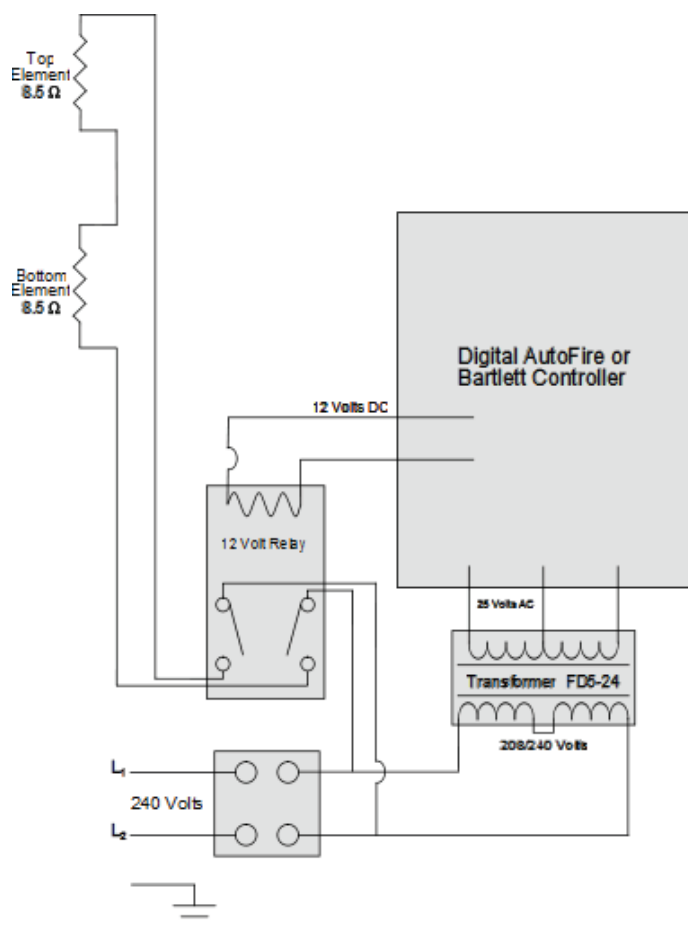

Crucible™ Kiln Model 122
208/240 Volts single-phase

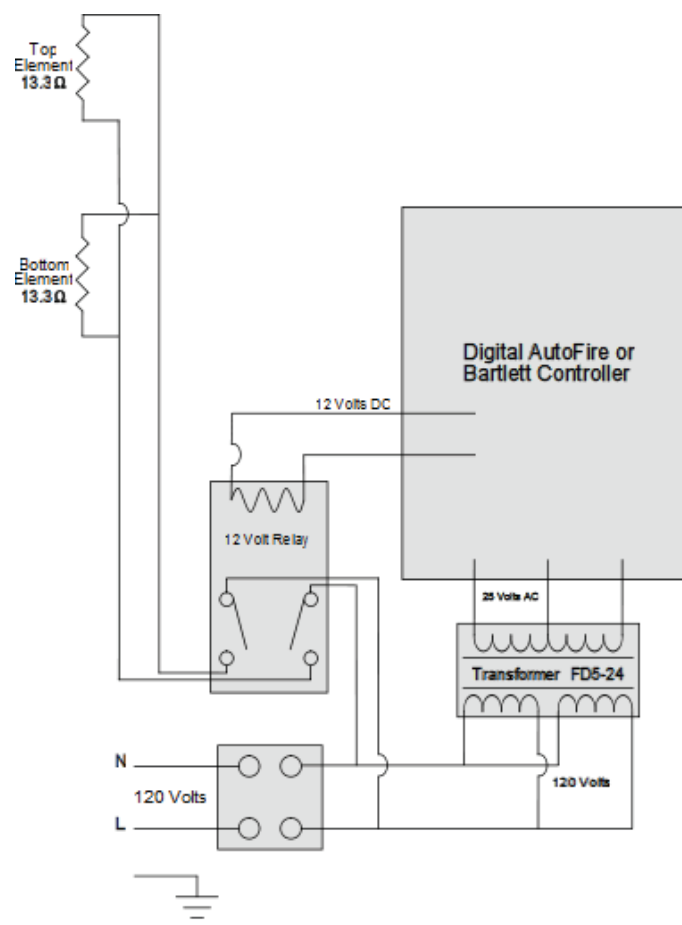

Crucible™ Kiln Model 122
120 Volts single-phase

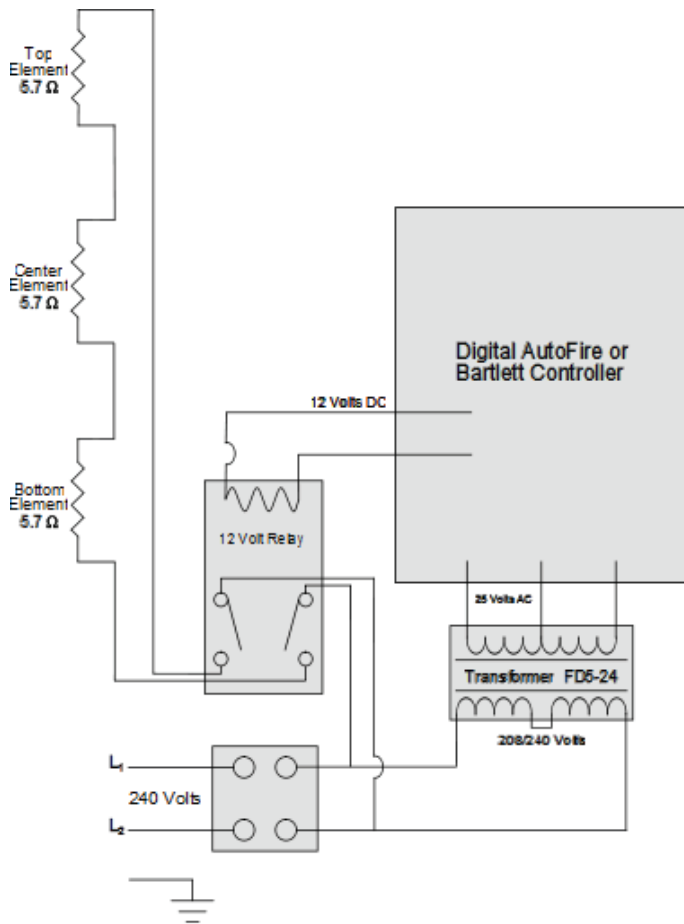

Crucible™ Kiln Model 123
208/240 Volts single-phase

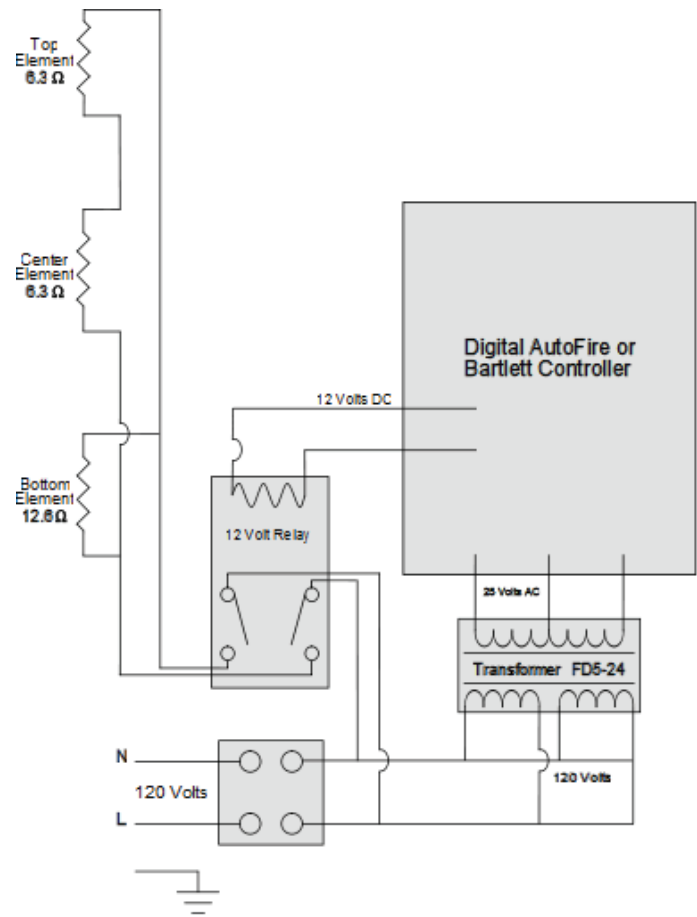

Crucible™ Kiln Model 123
120 Volts

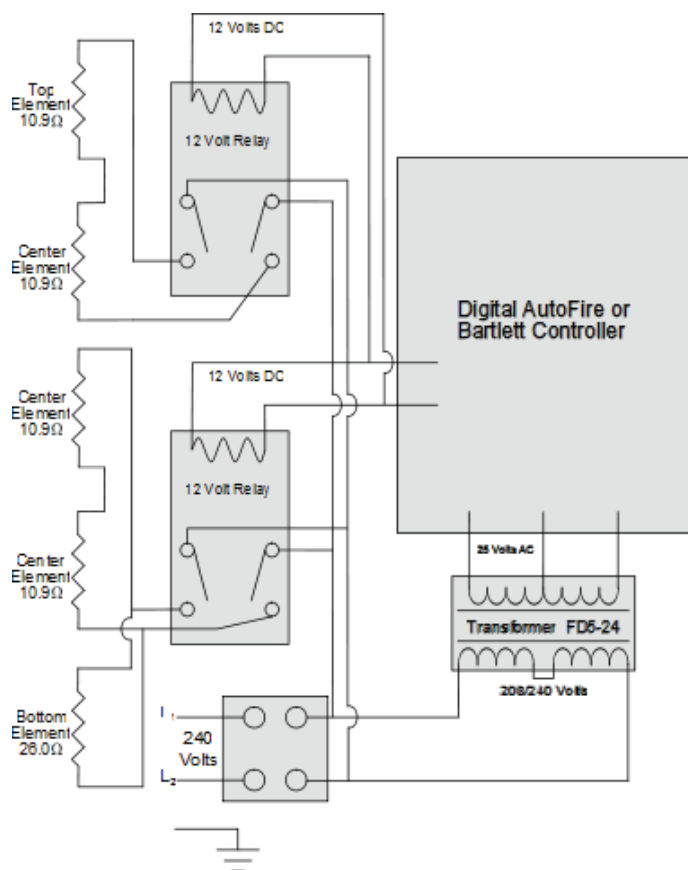

Crucible™ Kiln Model 185WR
208/240 Volts single-phase

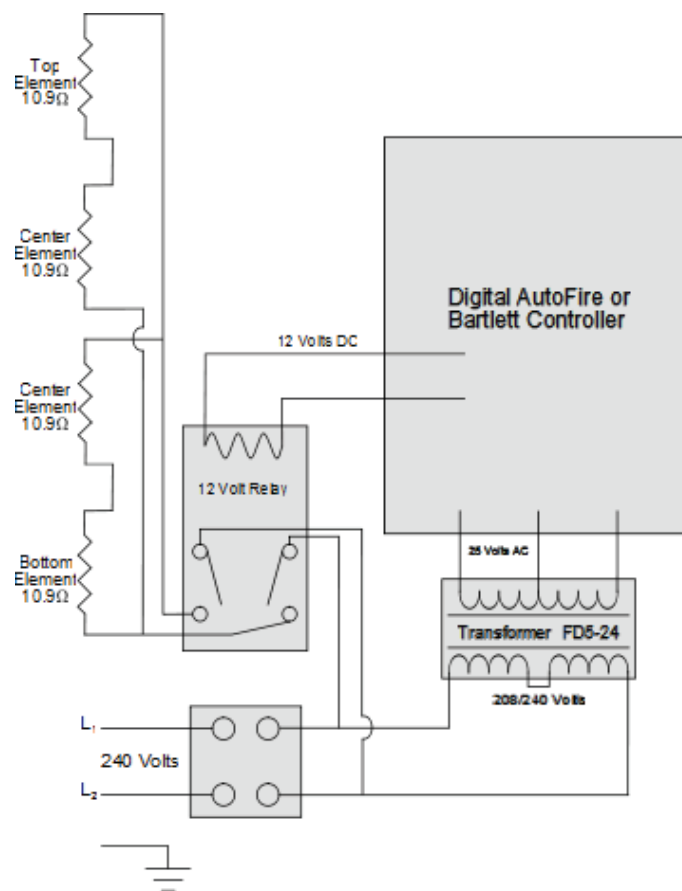

Crucible™ Kiln Model 184
208/240 Volts single-phase

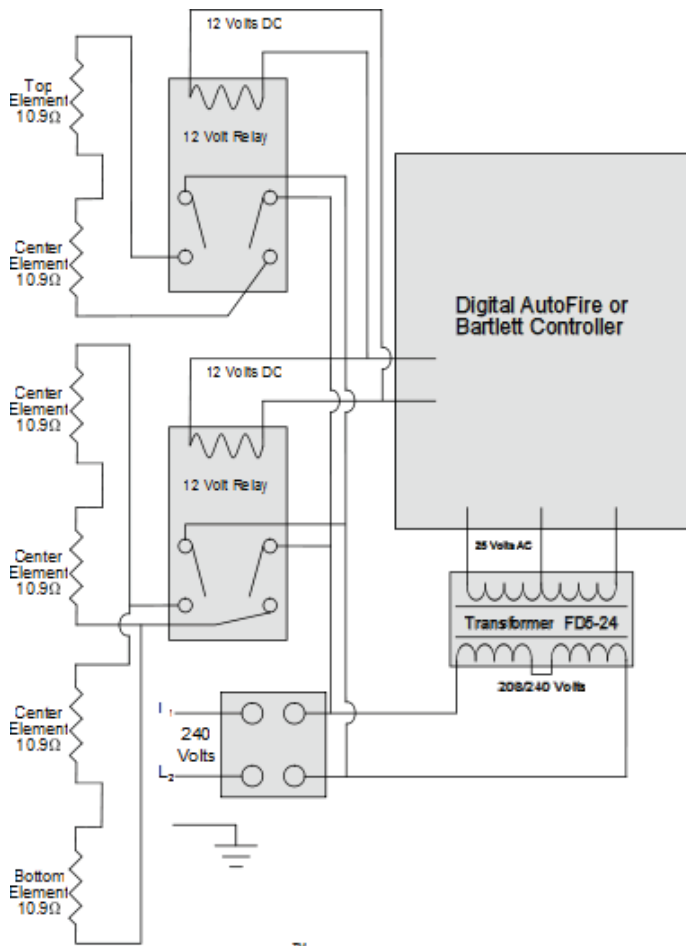

Crucible™ Kiln Model 186
208/240 Volts single-phase

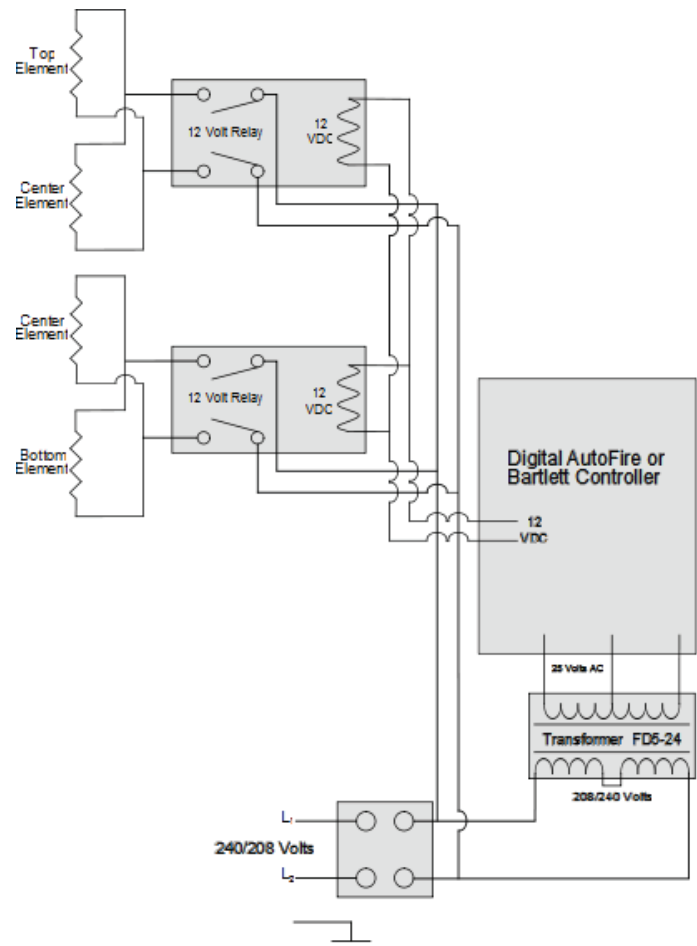

Crucible™ Kiln Models 234, 284, 254 Oval, 304 Oval
208/240 Volts Single-phase

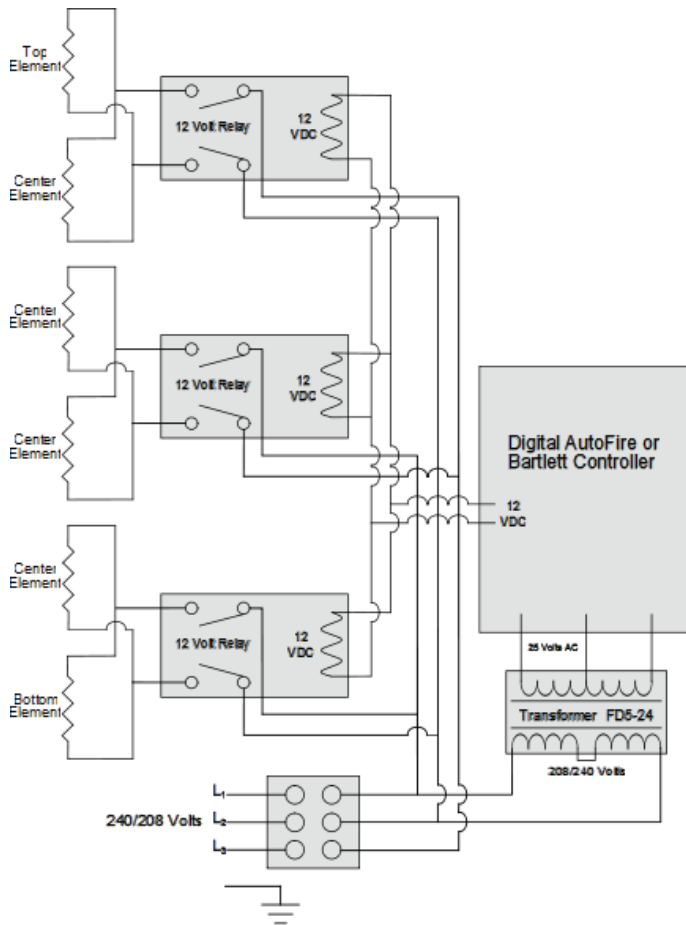

Crucible™ Kiln Models 236, 286,
25 Oval, 30 Oval
208/240 Volts 3-phase

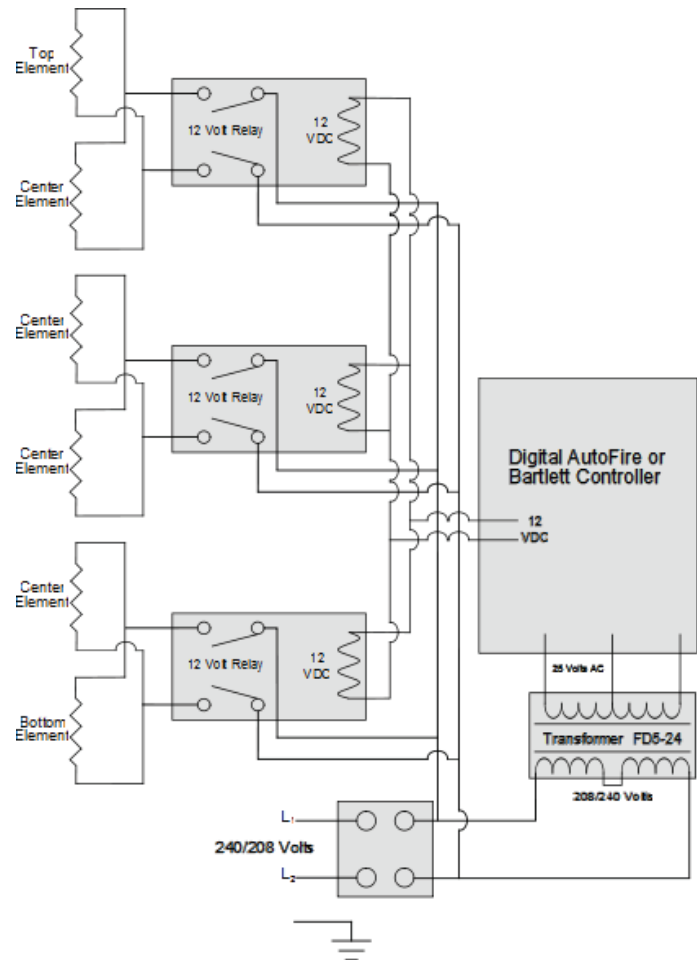

Crucible™ Kiln Models 236, 286,
25 Oval, 30 Oval
208/240 Volts Single-phase