

# JY9952BS01 / JY9952HS01

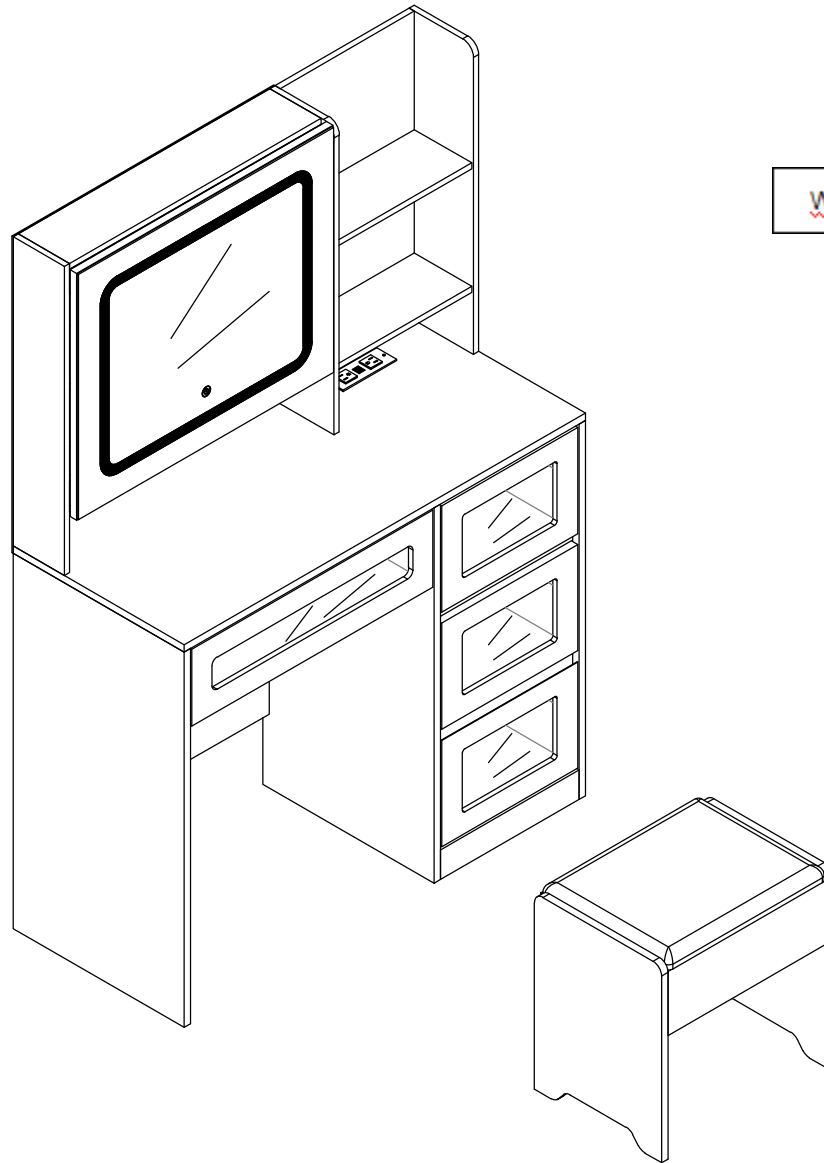

WhatsApp community†

As this item contains many parts, please read the installation instruction carefully before installation . Please use tools properly and carefully. If you have any questions about the product and installation, please contact us.

**[service@vabchesofficial.com](mailto:service@vabchesofficial.com)**

Our professional after-sales team will serve you online all day.

# Before You Start

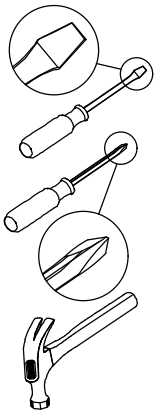

- ✓ Read through each step carefully and follow the proper order
- ✓ Separate and count all your parts and hardware
- ✓ Give yourself enough room for the assembly process
- ✓ Have the following tools: Flat Head Screwdriver, #2 Phillips Head Screwdriver and Hammer
- ✓ Caution: If using a power drill or power screwdriver for screwing, please be aware of to slow down and stop when screw is tight. Failure to do so may result in stripping the screw. (Assembly speed can be increased by using electric screwdriver)

# Helpful Hints

## PEOPLE NEEDED FOR ASSEMBLY: 1-2

- Open your item in the area you plan to keep it to avoid excessive heavy lifting.
- Identify, sort and count the parts before attempting assembly.
- Compression dowels are lightly tapped in with a hammer.
- Slides are labeled with an **R** (right) and **L** (left) for proper placement.
- Make sure to always face the point on the top of the Cam Lock towards the outer edge.
- If there is a back panel in the package, please install it to make sure your unit is complete and sturdy.
- Please fix all the screws provided for the back panel which can enhance product stability. If it is difficult to fix it when tightening, it can be fixed with the help of a hammer and then tightened.
- Do NOT use harsh chemicals or abrasive cleaners on this item.
- Never push, pull, or drag your furniture.



# Board Identification

Not actual size

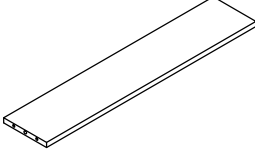
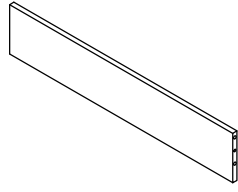
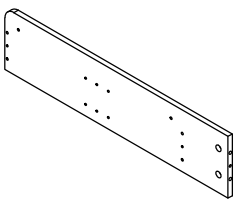
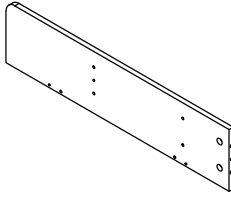
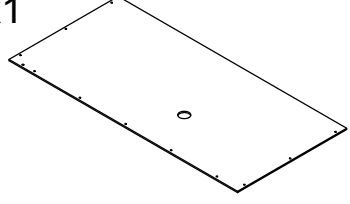
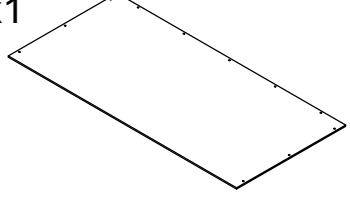
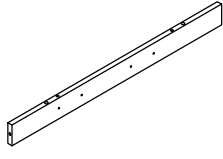
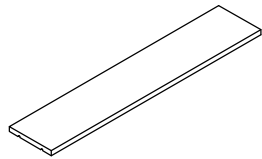
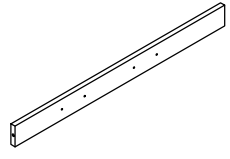
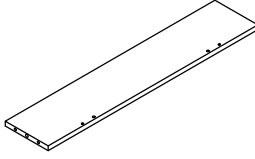
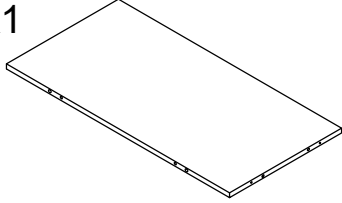
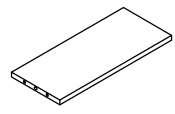
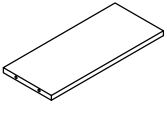
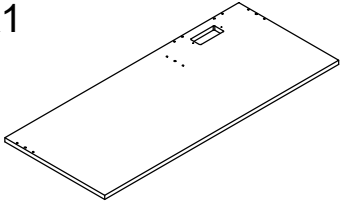
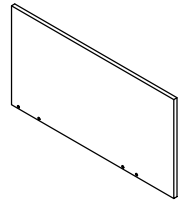
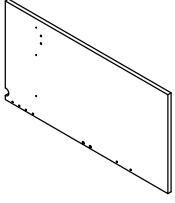
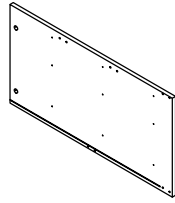
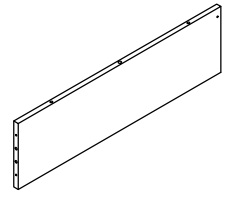
①x1 	②x1 	③x1 
Apical panle	upper cabinet left panel	upper cabinet middle panel
④x1 	⑤x1 	⑥x1 
upper cabinet right panel	Back plate	Back plate
⑦x1 	⑧x1 	⑨x1 
upper cabinet connected plate	Movable shelf	upper cabinet connected plate
⑩x1 	⑪x1 	⑫x1 
upper cabinet connected plate	Back panel	upper cabinet connected plate
⑬x1 	⑭x1 	⑮x1 
upper cabinet connected plate	Desktop board	lower cabinet left panel
⑯x1 	⑰x1 	⑱x1 
lower cabinet middle panel	lower cabinet right panel	lower cabinet connected plate

# Board Identification

Not actual size

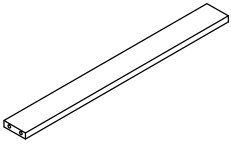
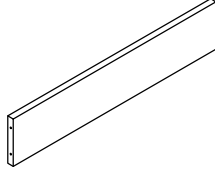
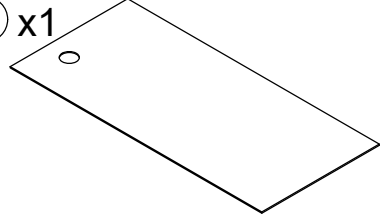
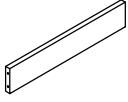
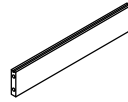
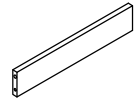
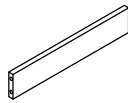
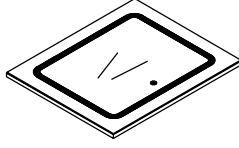
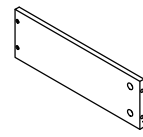
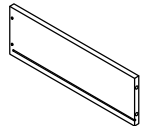
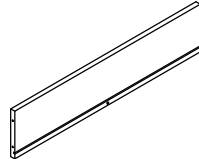
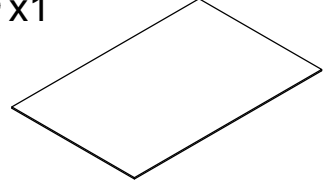
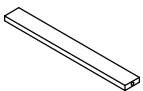
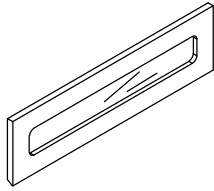
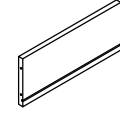
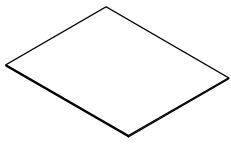
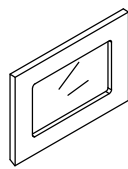
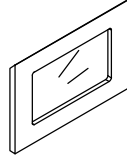
<p>①9 x1</p> 	<p>②0 x1</p> 	<p>②1 x1</p> 
lower cabinet connected plate	lower cabinet connected plate	Back plate
<p>②2 x1</p> 	<p>②3 x1</p> 	<p>②4 x2</p> 
lower cabinet connected plate	lower cabinet connected plate	lower cabinet connected plate
<p>②5 x1</p> 	<p>②6 x1</p> 	<p>②7 x4</p> 
lower cabinet connected plate	Door	Drawer left side plate
<p>②8 x4</p> 	<p>②9 x1</p> 	<p>③0 x1</p> 
Drawer right side plate	Rear panel of drawer	Drawer base plate
<p>③1 x1</p> 	<p>③2 x1</p> 	<p>③3 x3</p> 
Underdrawer support plate	Drawer panel	Rear panel of drawer
<p>③4 x3</p> 	<p>③5 x2</p> 	<p>③6 x1</p> 
Drawer base plate	Drawer panel	Drawer panel

# Board Identification

Not actual size

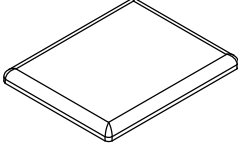
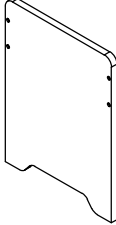
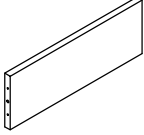
<p>③⑦ x1</p> 	<p>③⑧ x2</p> 	<p>③⑨ x2</p> 
<p>Apical panle of stool</p>	<p>Lateral plate of stool</p>	<p>connected plate of stool</p>

# Part List

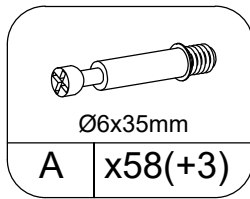

Cam Bolt

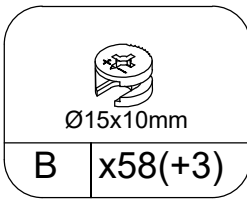

Cam Lock

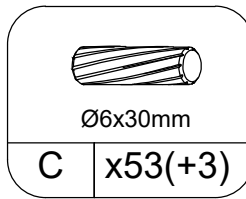

Dowel

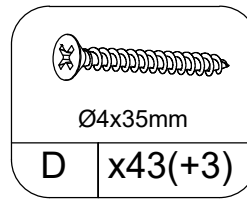

Screw

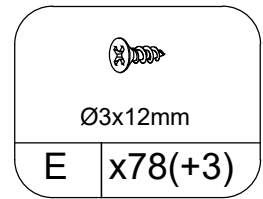

Screw

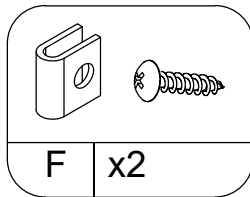

Wire Clip

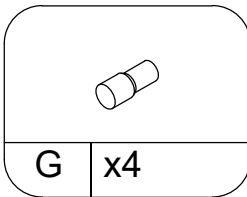

Shelf pin

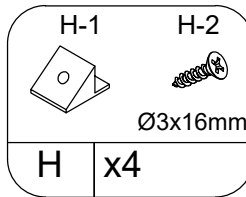

Back Buckle and screw

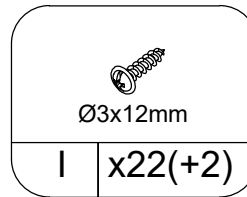

Screw

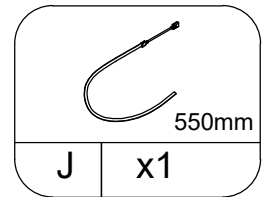

Strip light

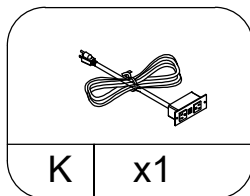

Electrical outlet

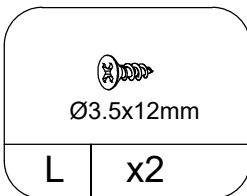

Screw

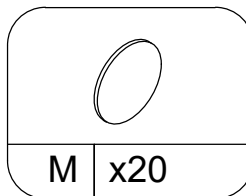

Hole sticker

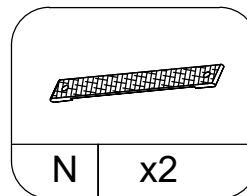

Anti-Fall Strip

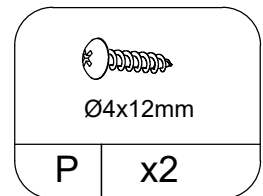

Screw

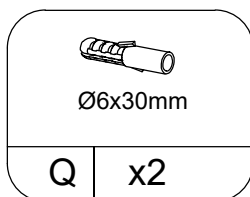

Plastic Expansion

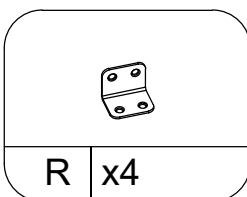

L-iron

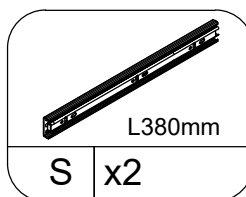

Sliding Track

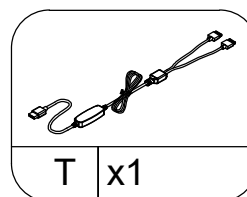

Electric wire

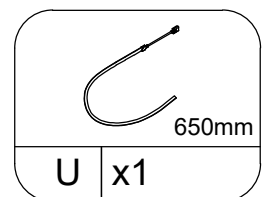

Strip light

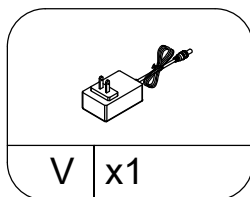

Plug

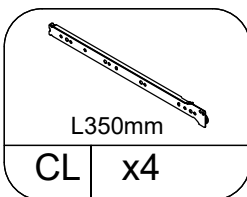

Sliding Track

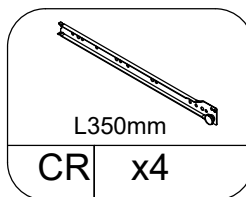

Sliding Track

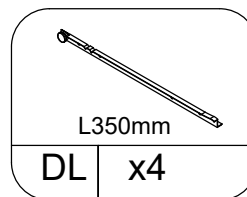

Sliding Track

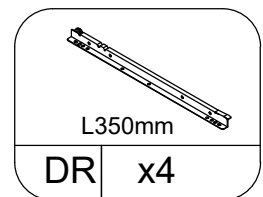

Sliding Track

# Part List

## Cam Lock Fastening System

Insert the cam bolt into the hole first, then insert the cam lock and lock it.

**1**

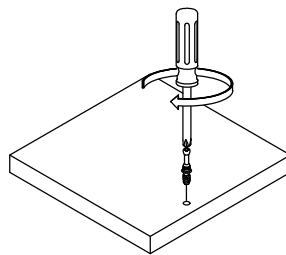

**2**

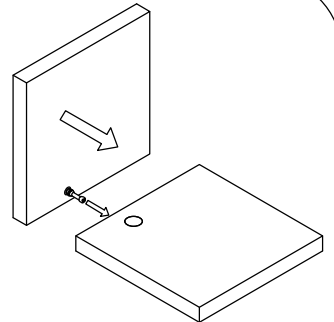

**3**

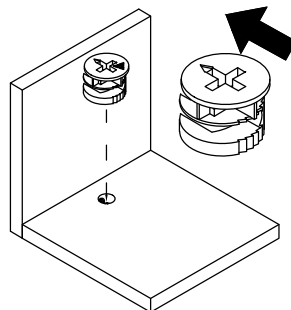

The opening must point toward the edge of the board

**4**

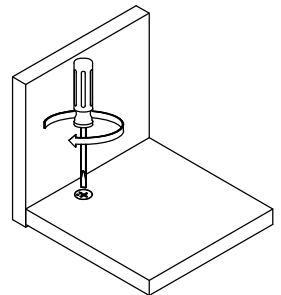

# Board Identification

Not actual size

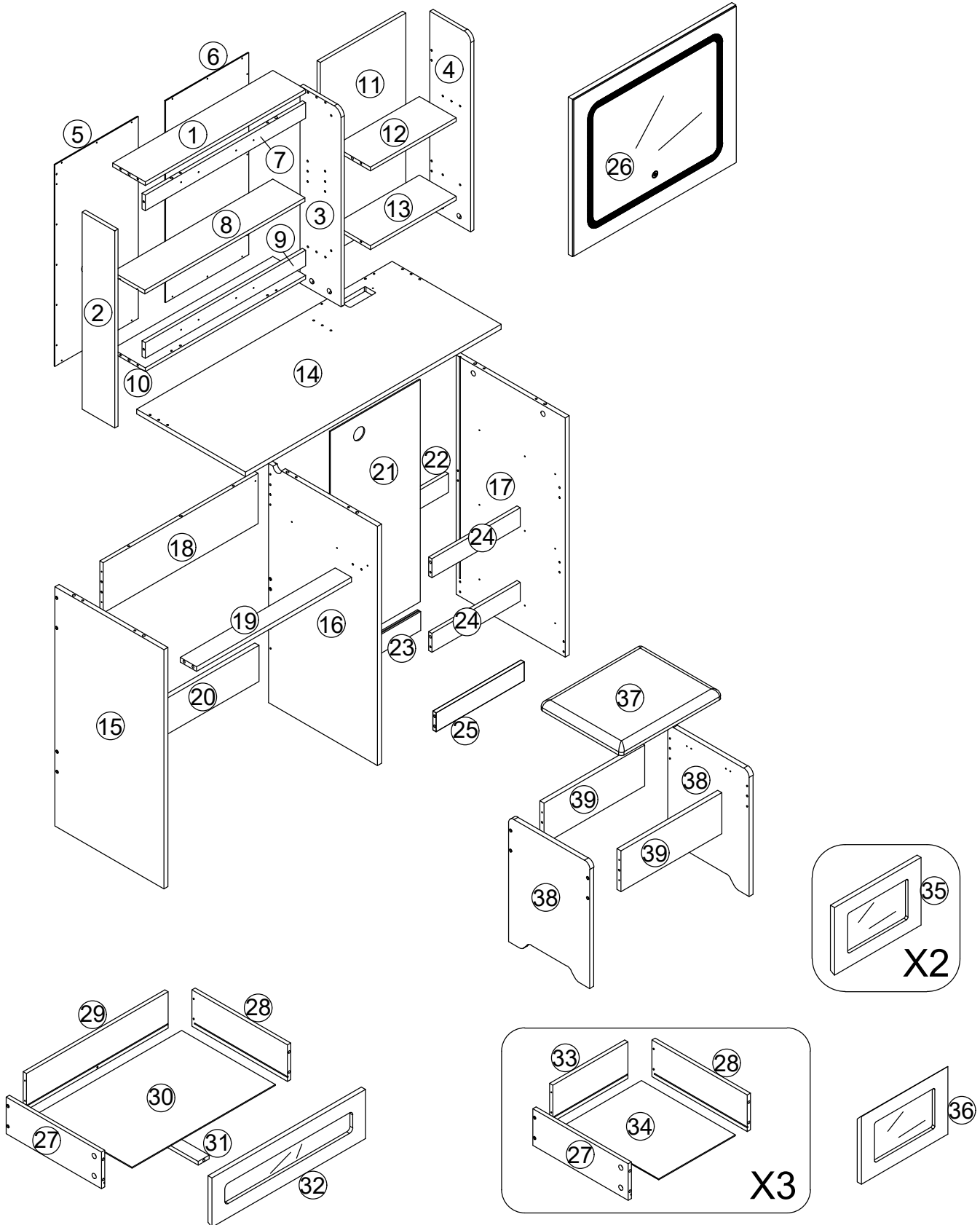



# STEP 1

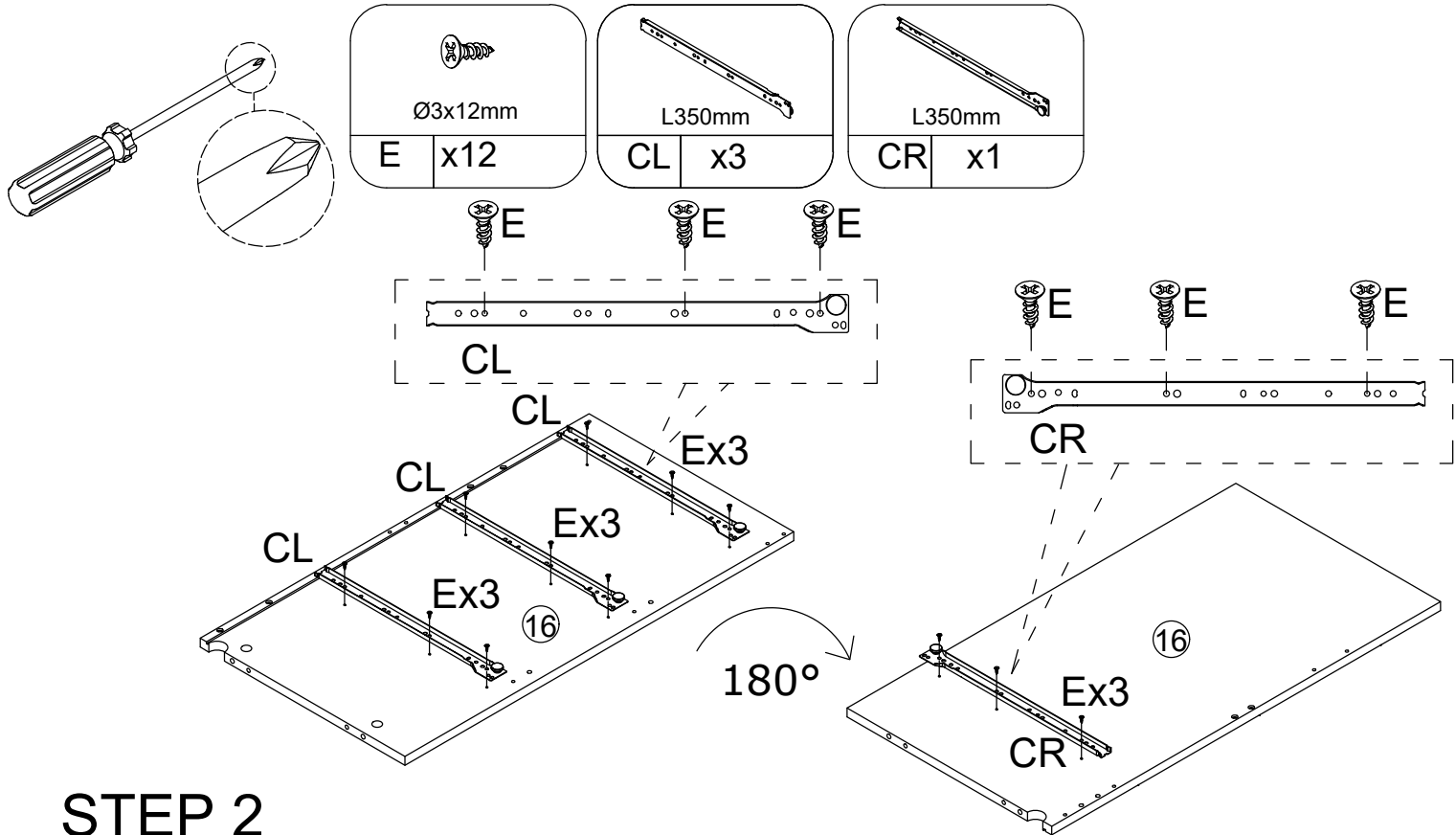

# STEP 2

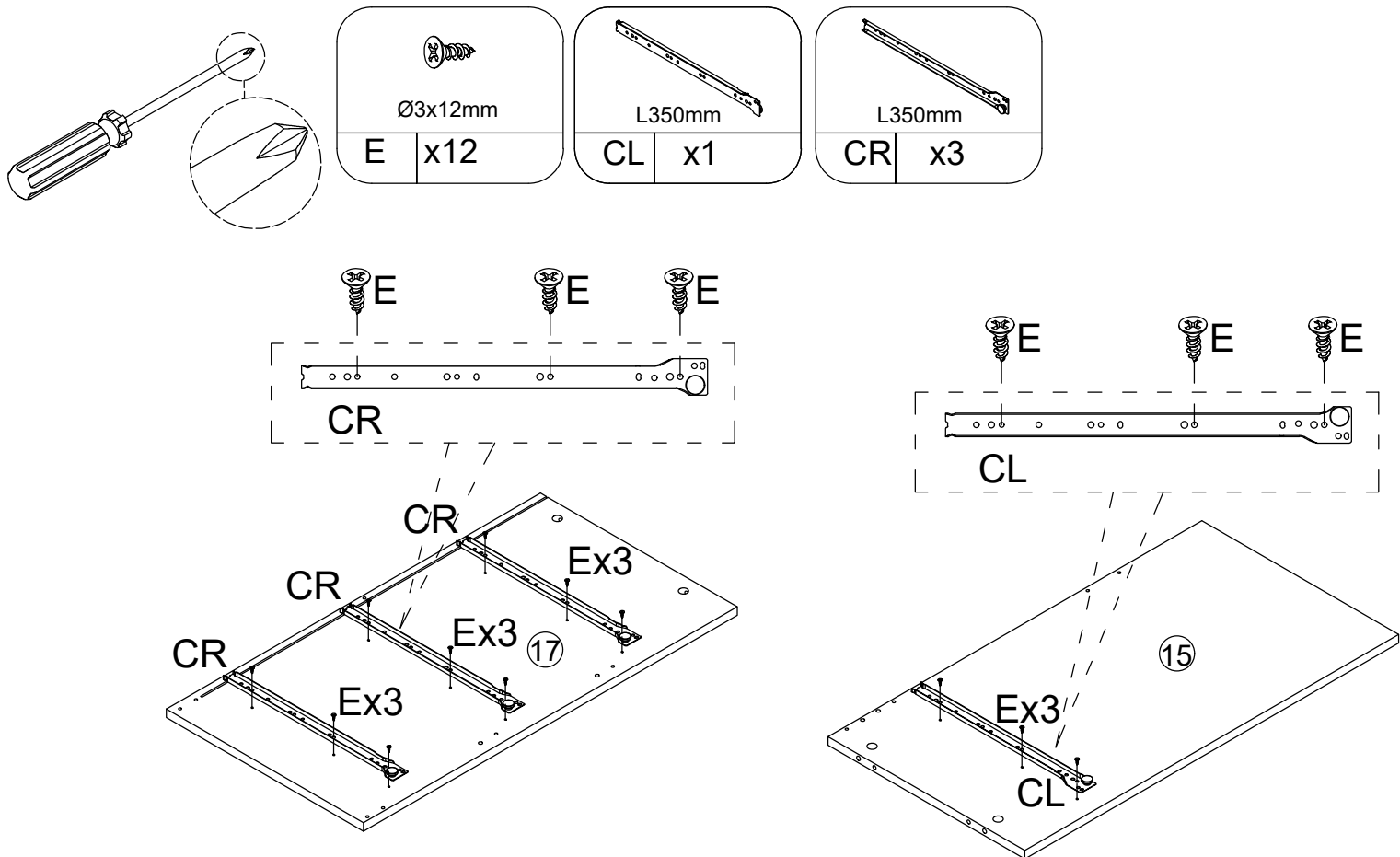

# STEP 3

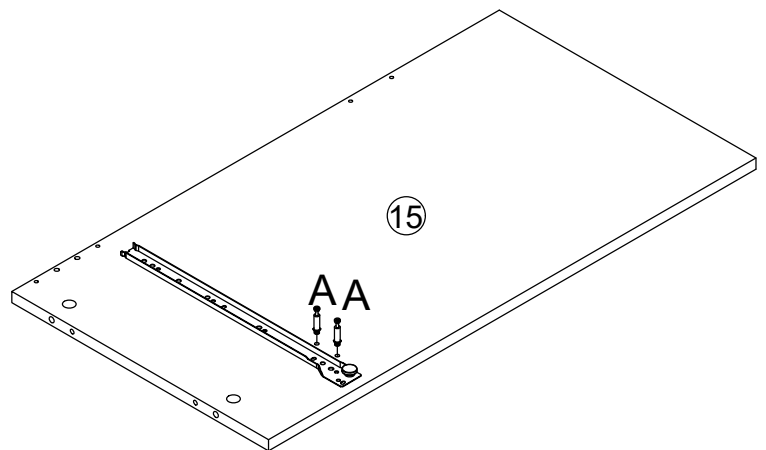
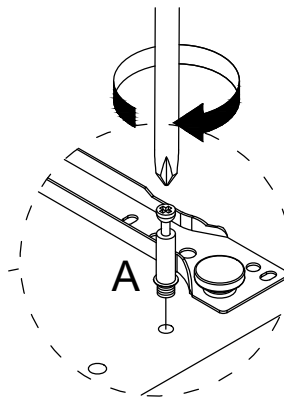
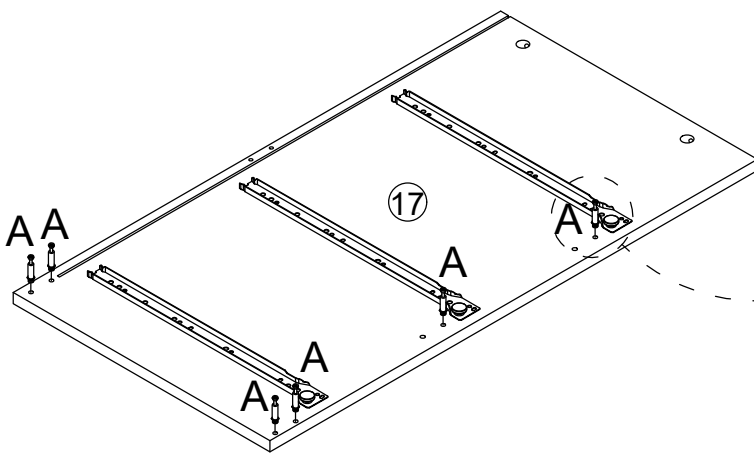
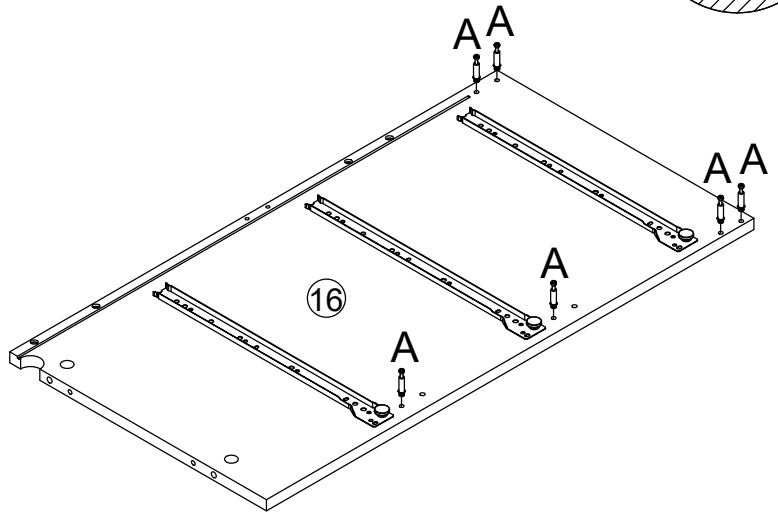
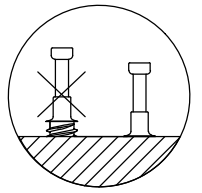
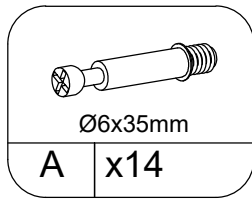
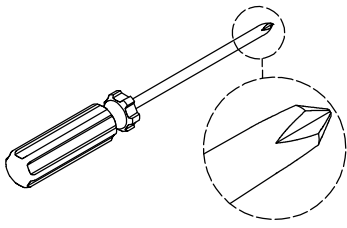

# STEP 4

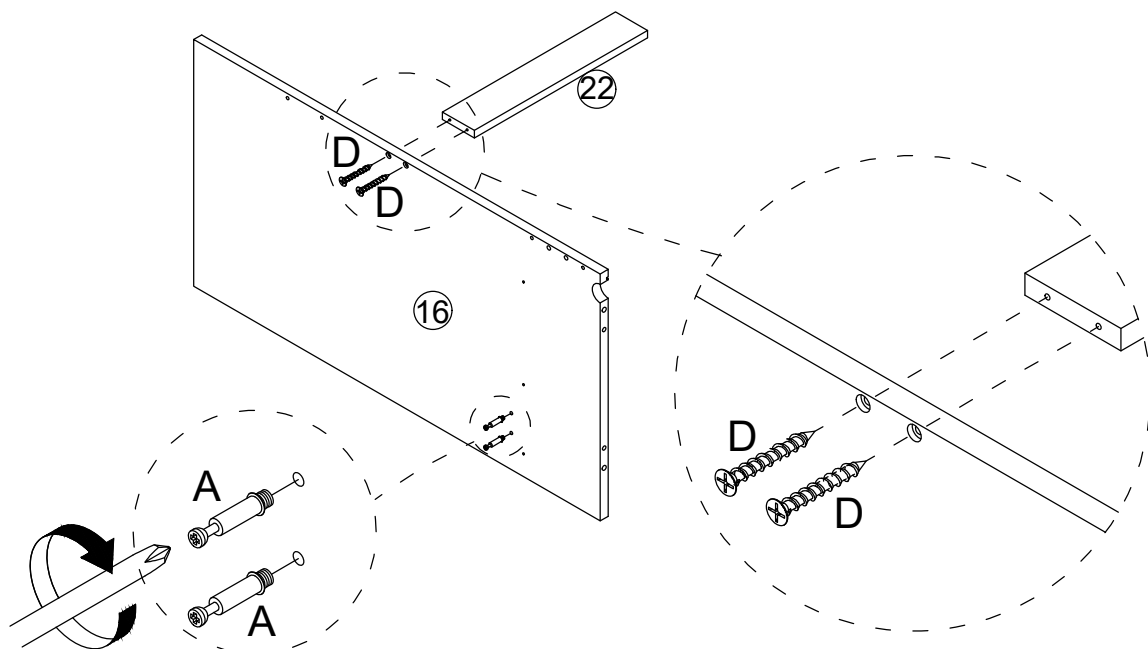
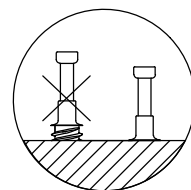
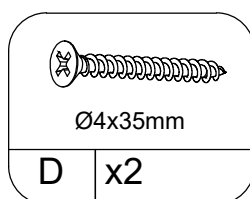
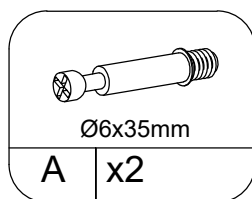
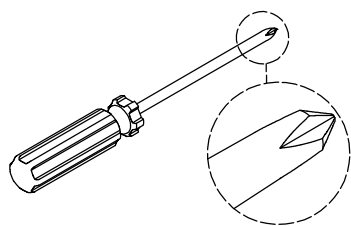

# STEP 5

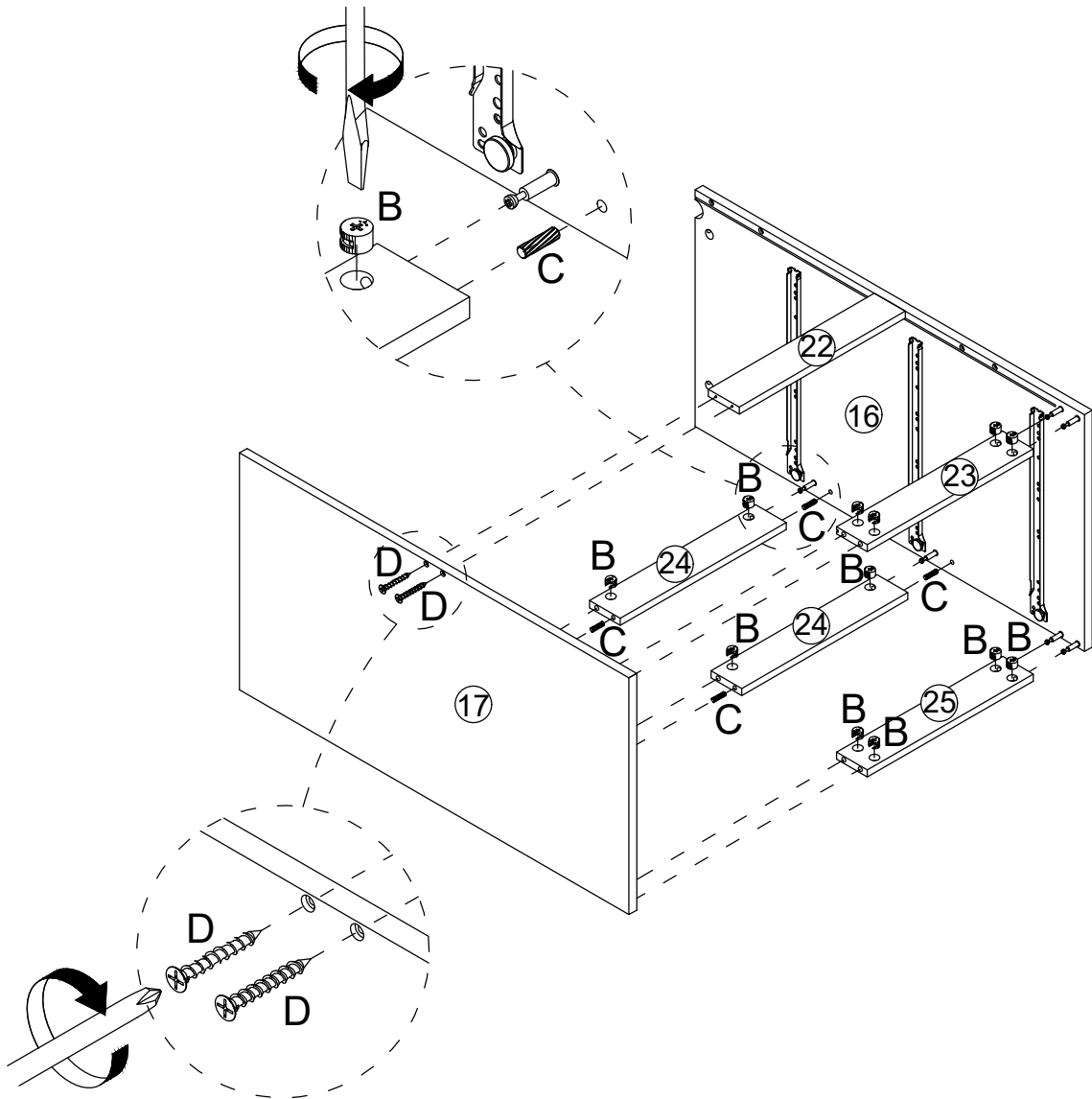
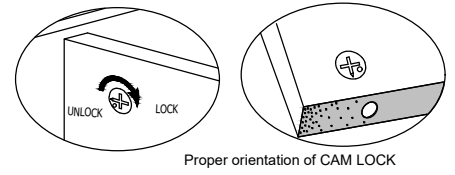
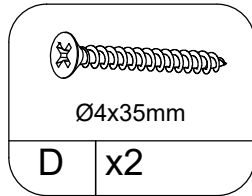
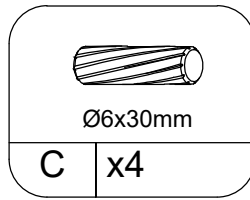
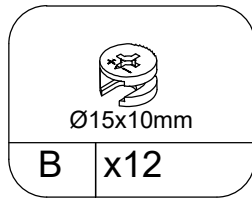
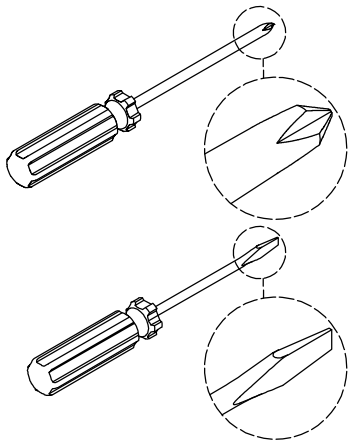

# STEP 6

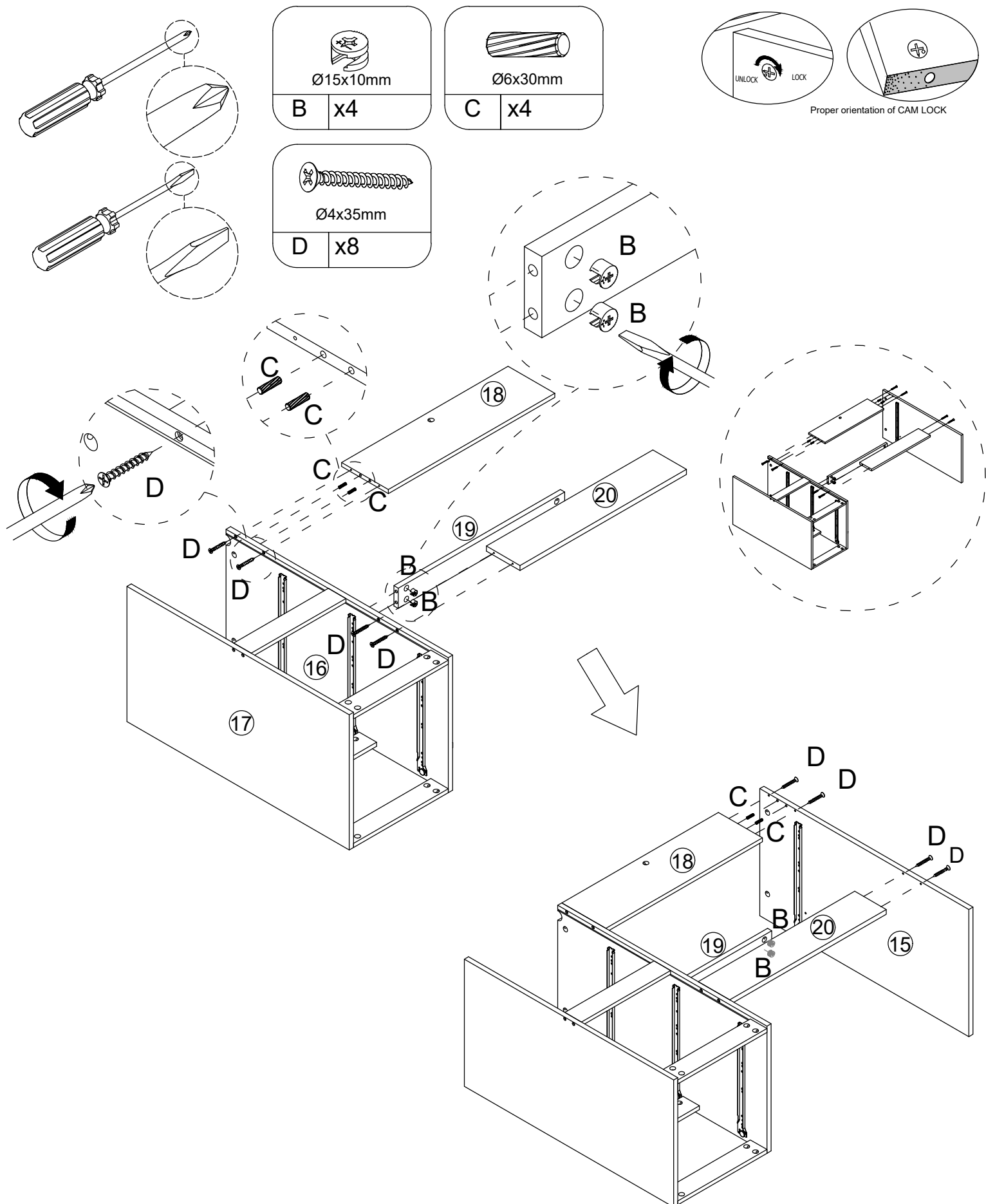

# STEP 7

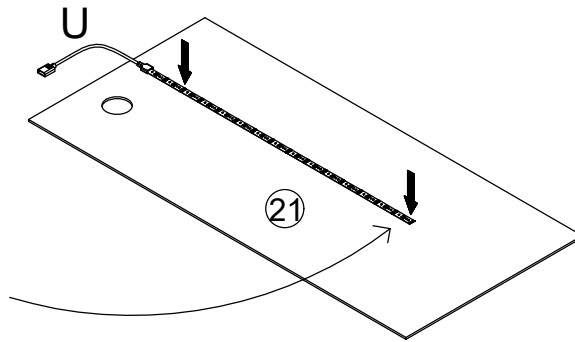
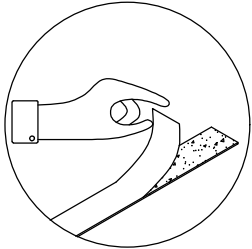
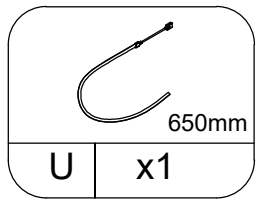

# STEP 8

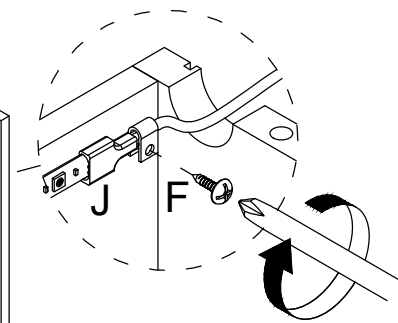
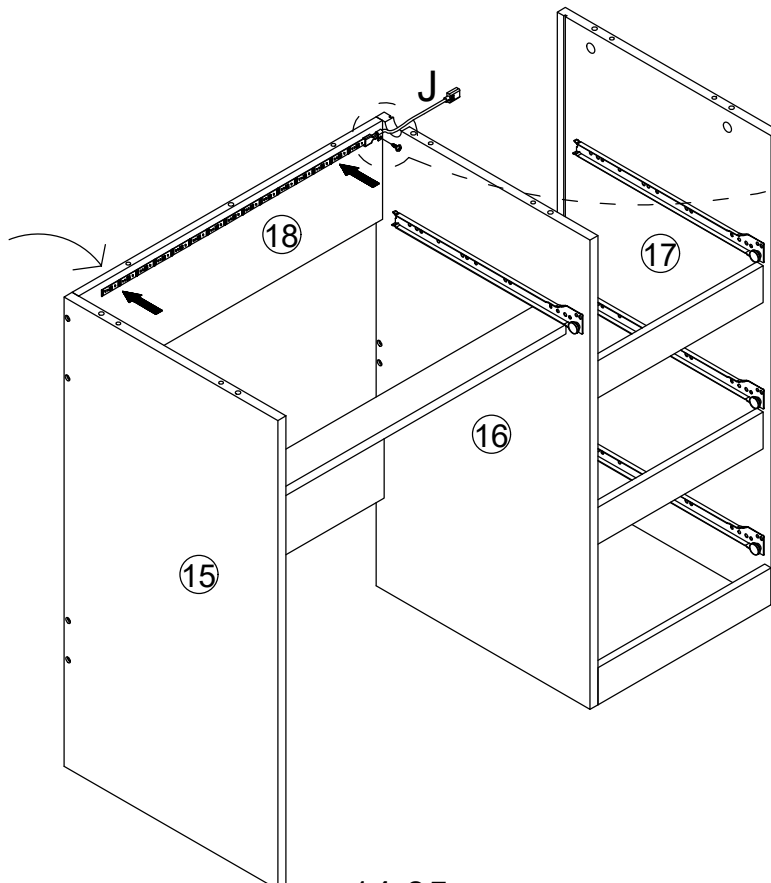
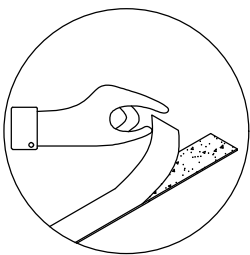
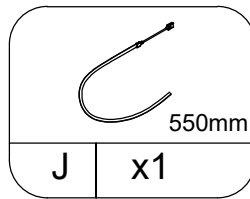
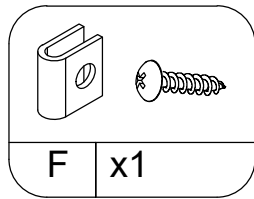
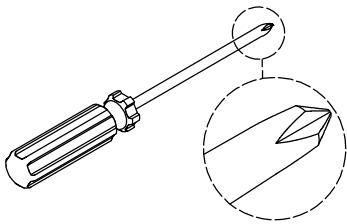

# STEP 9

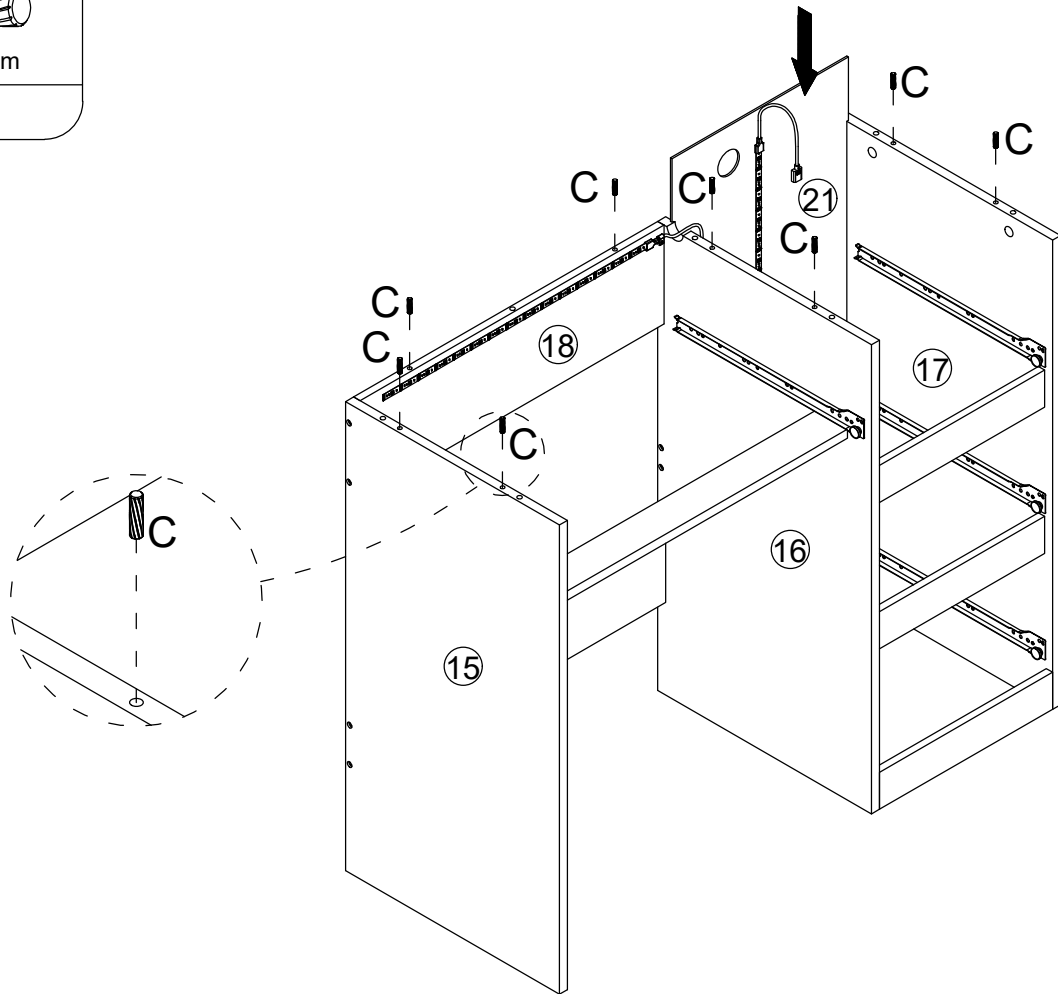
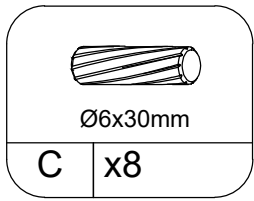

# STEP 10

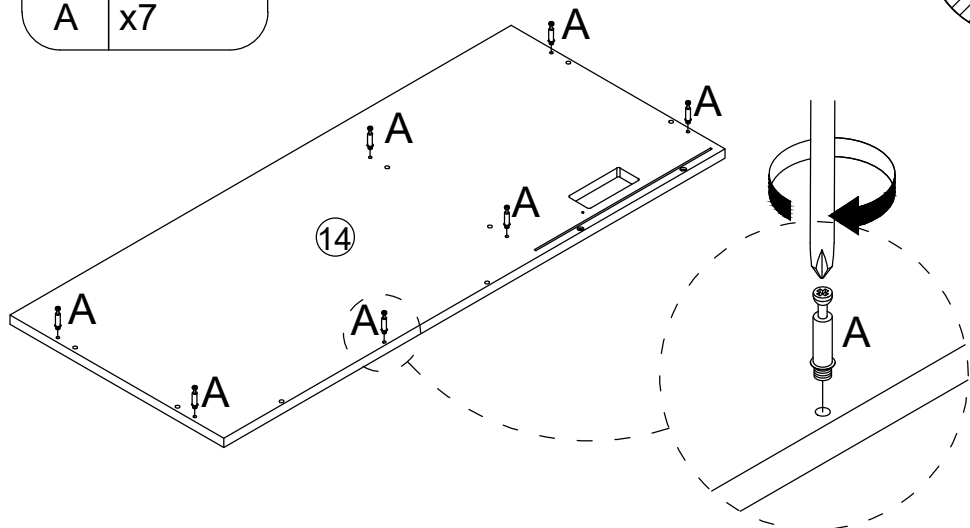
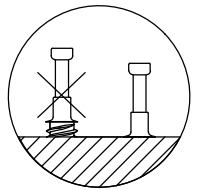
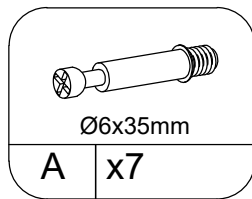
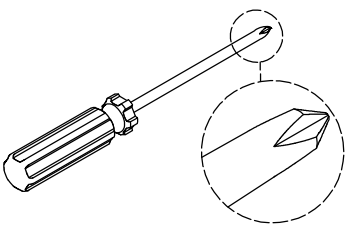

# STEP 11

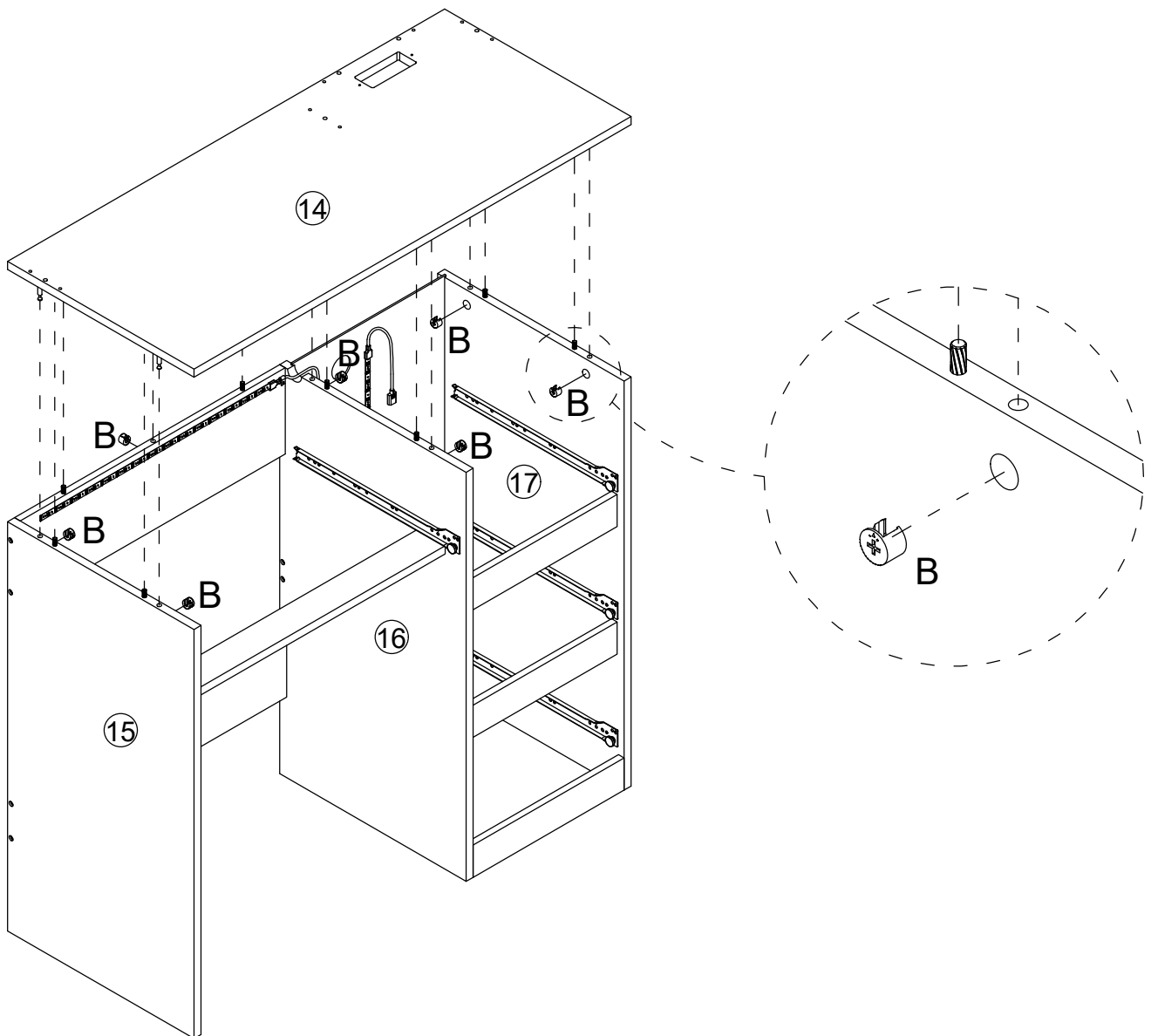
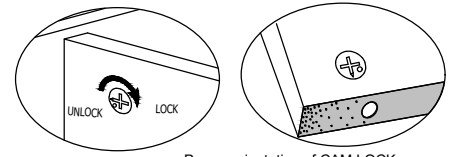
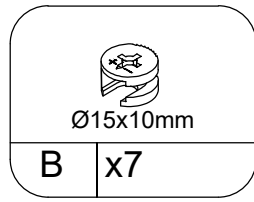
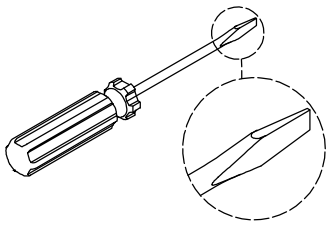



# STEP 12

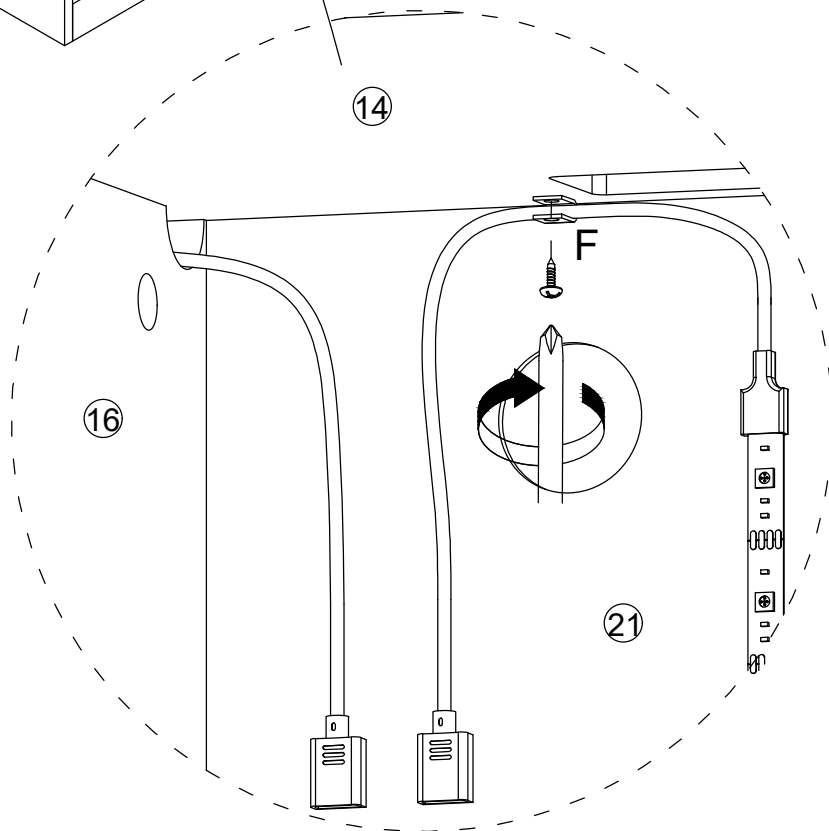
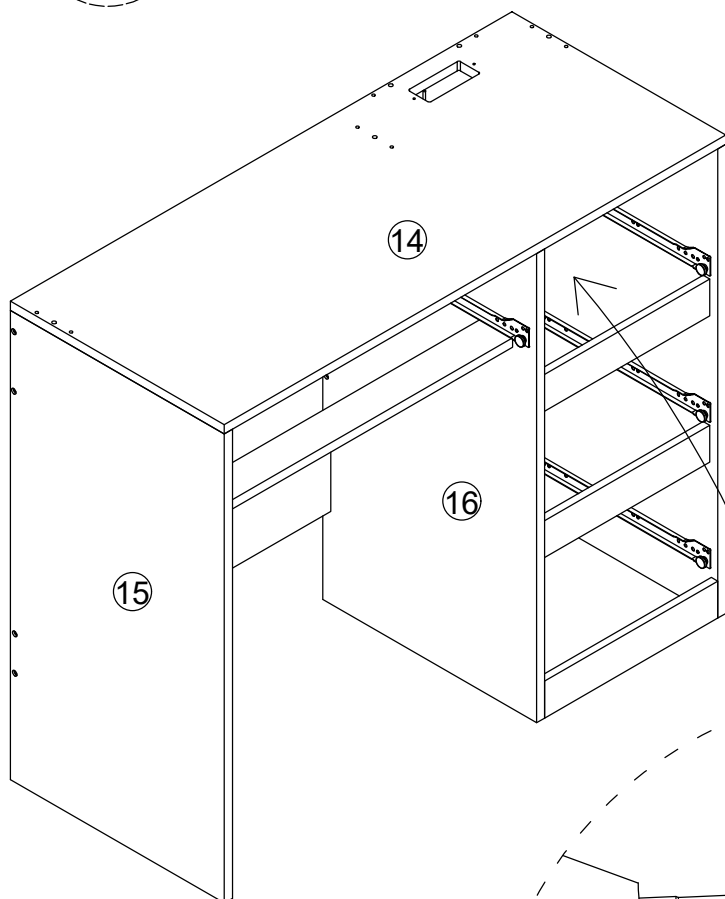
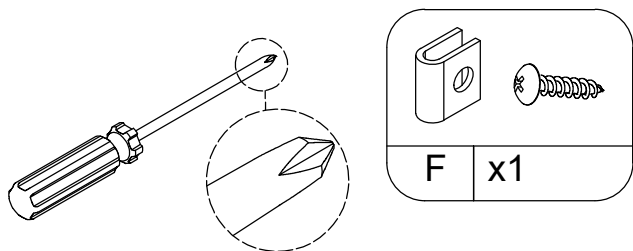

# STEP 13

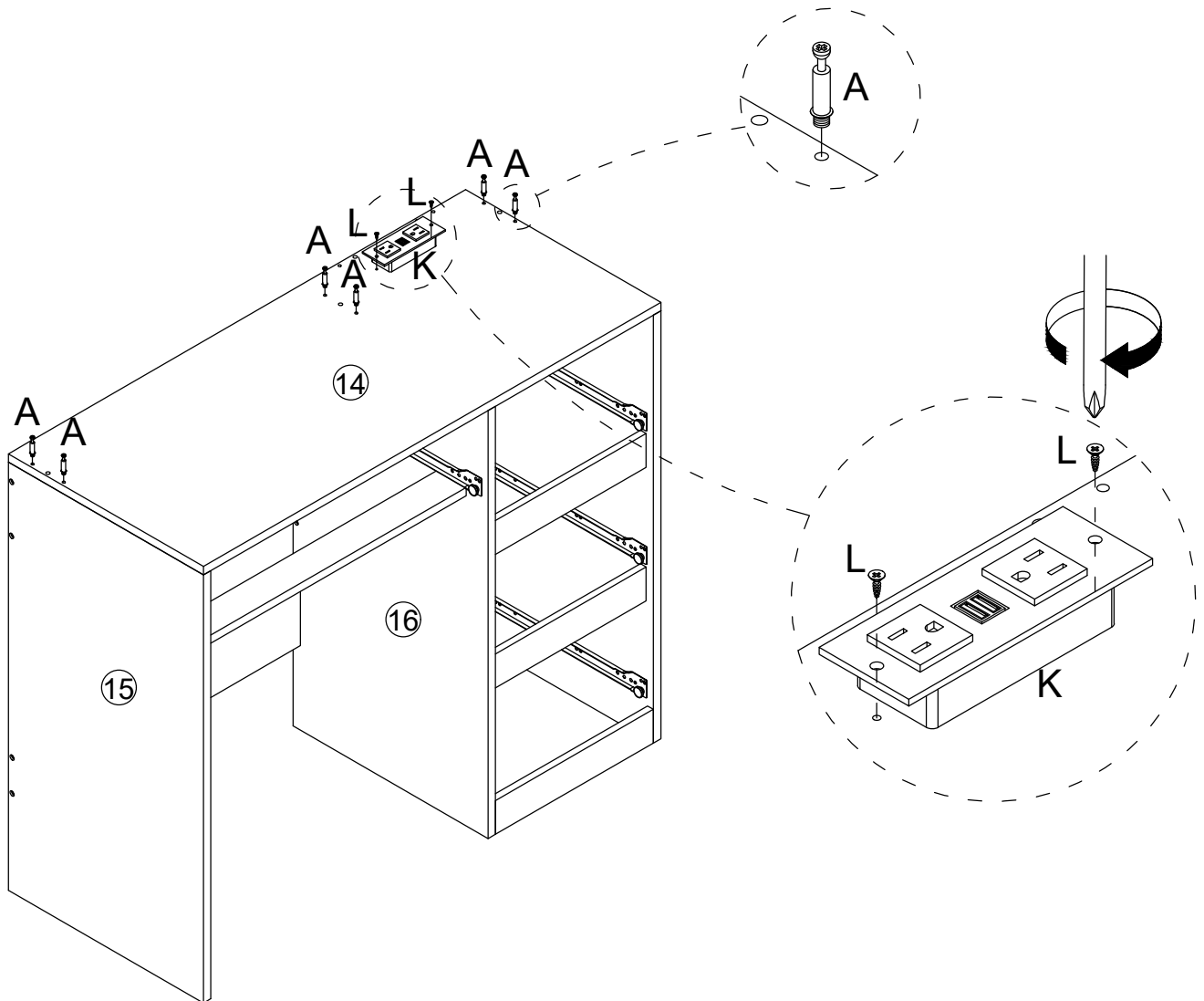
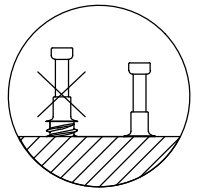
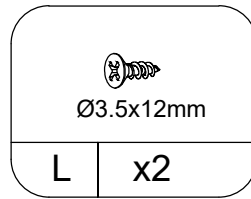
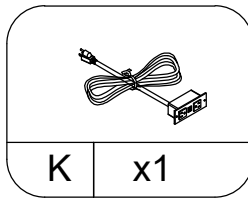
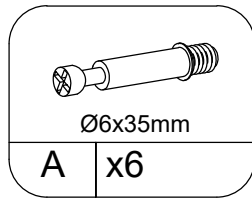
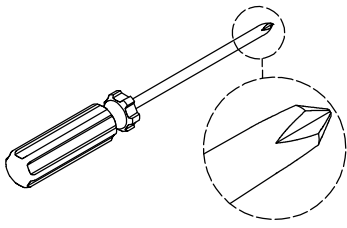

# STEP 14

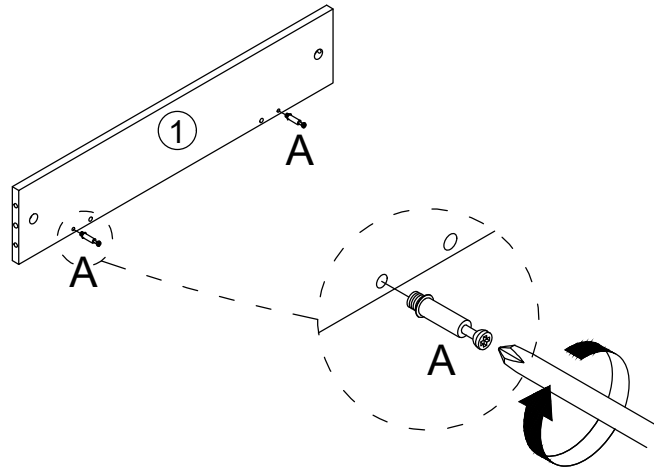
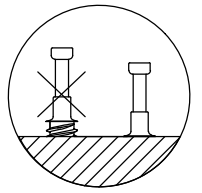
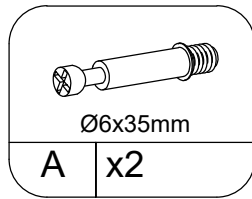
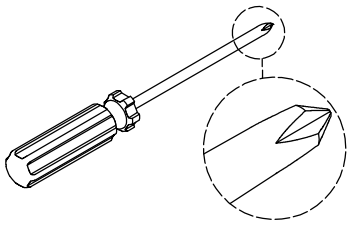

# STEP 15

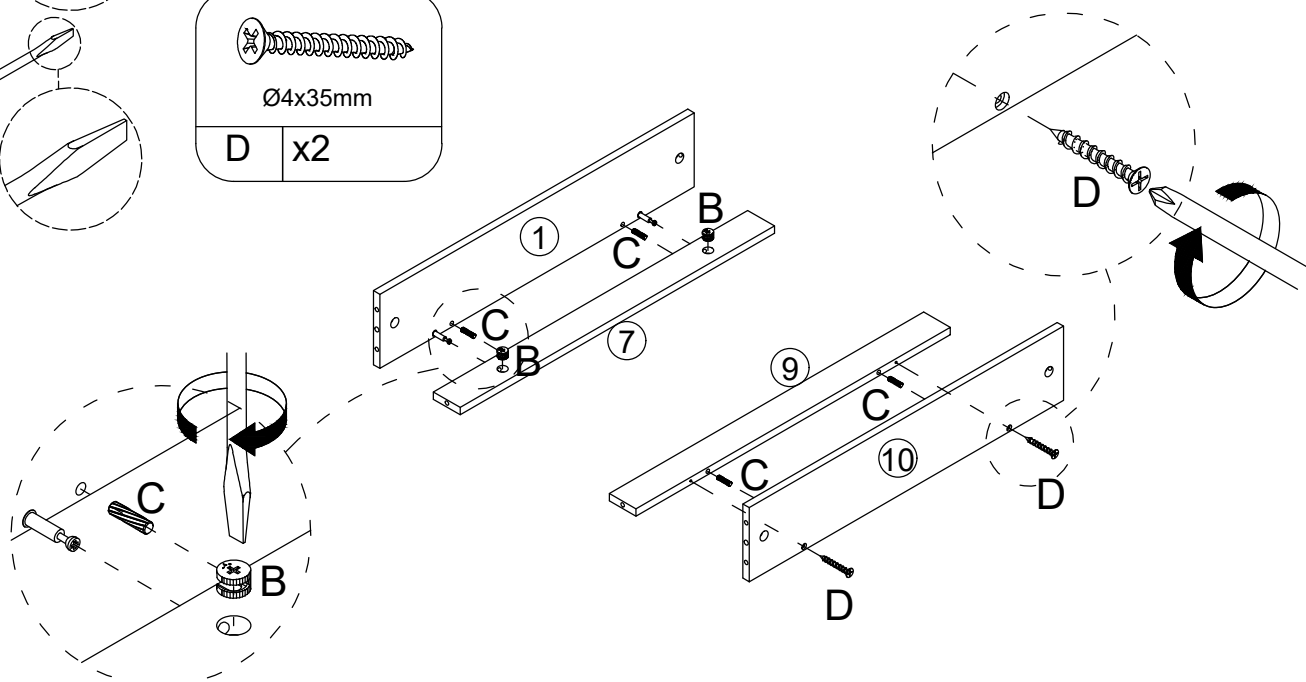
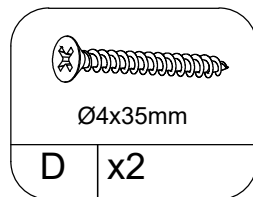
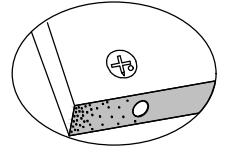
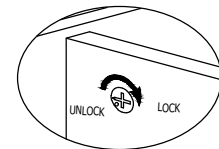
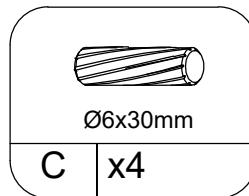
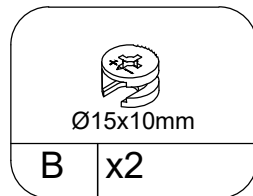
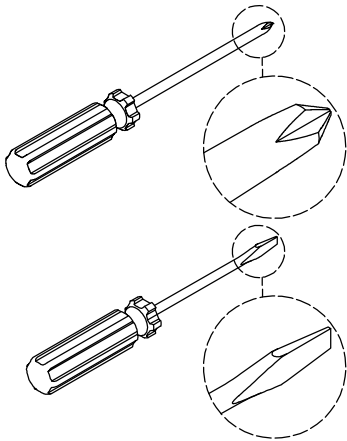

# STEP 16

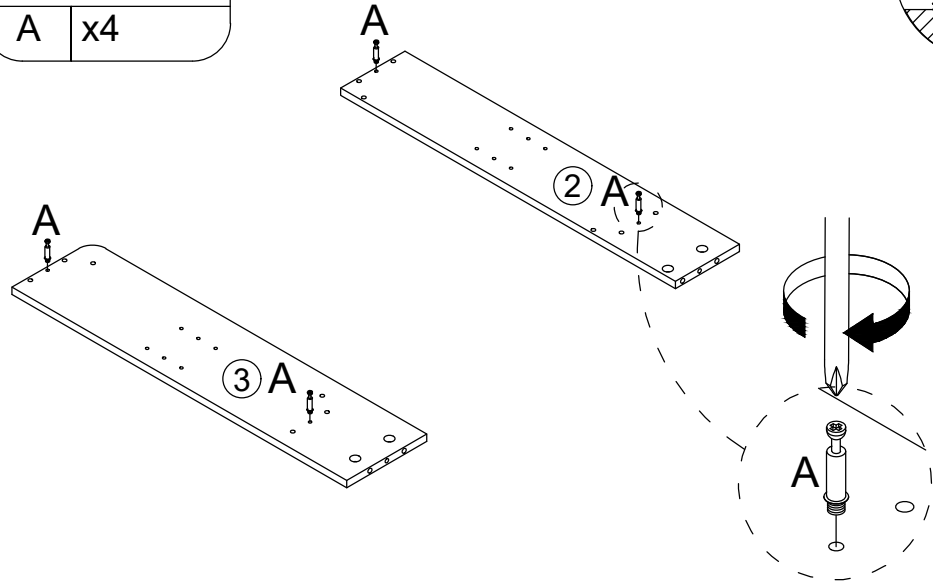
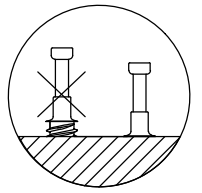
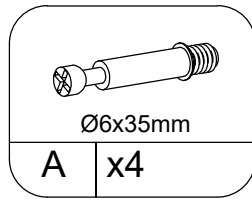
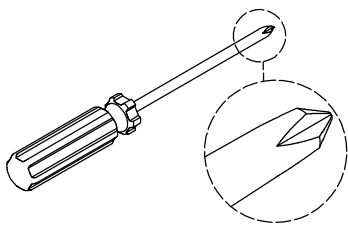

# STEP 17

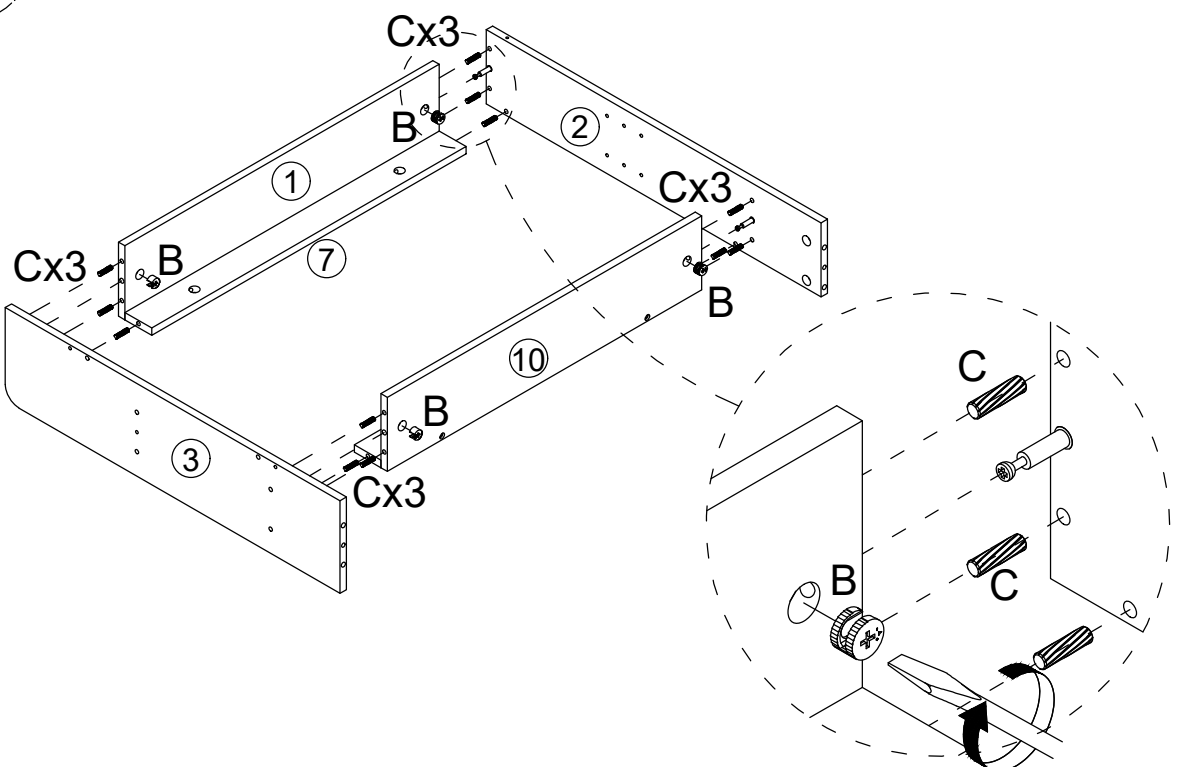
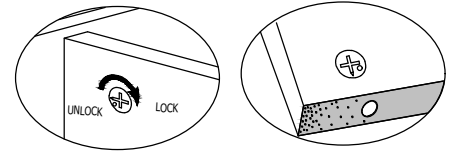
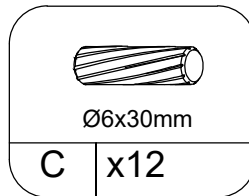
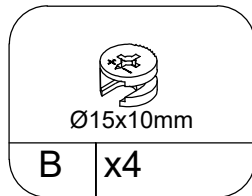
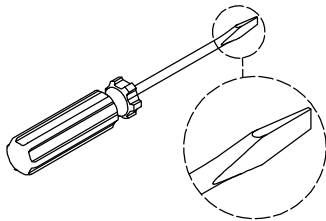

# STEP 18

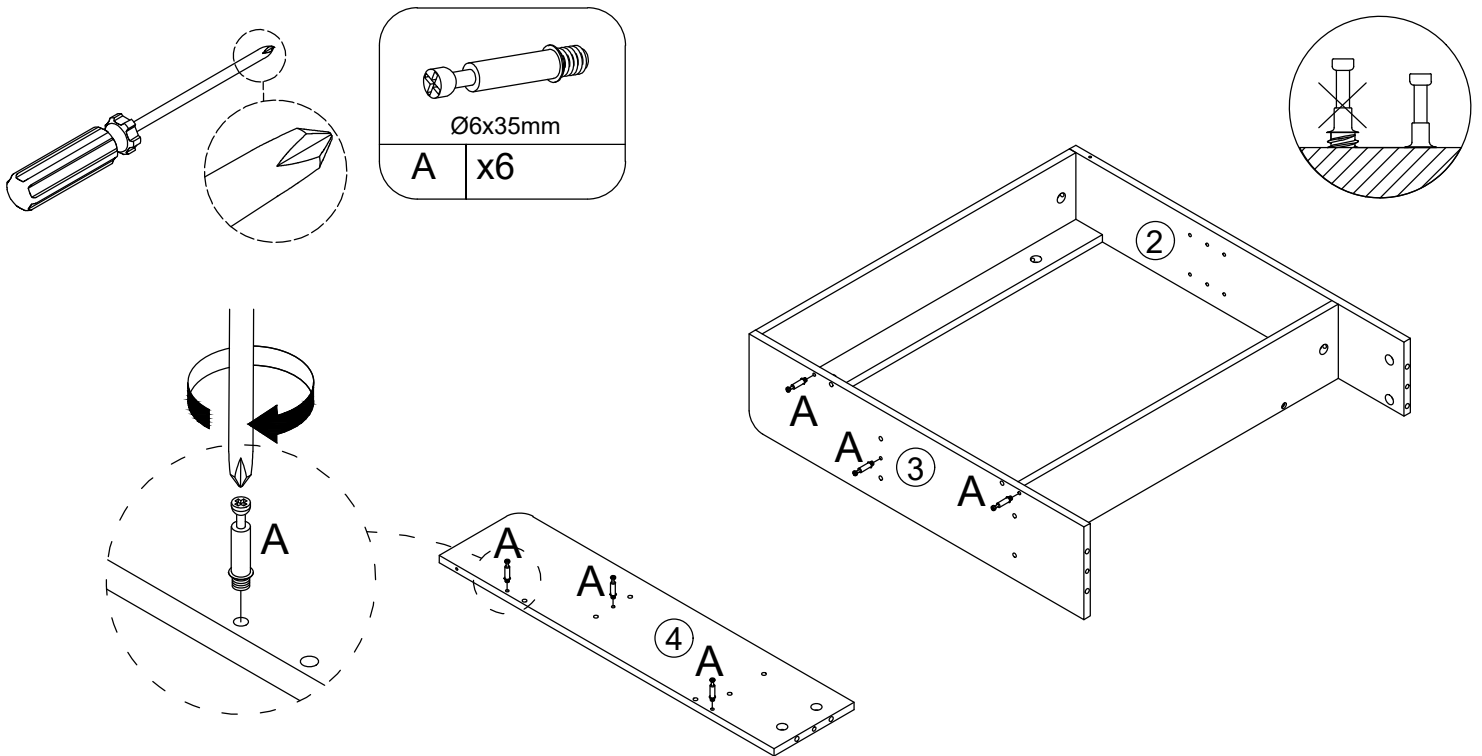

# STEP 19

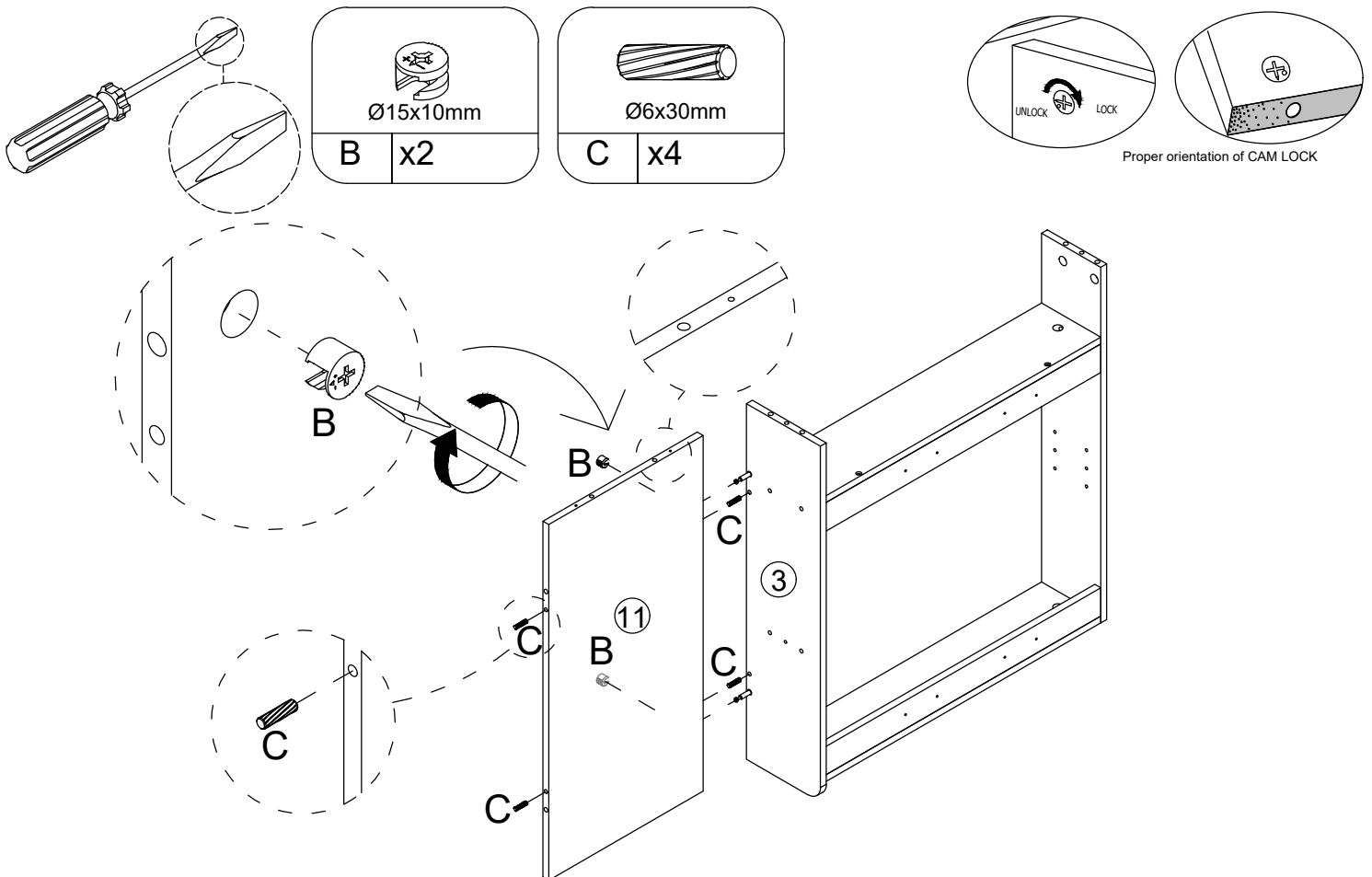

# STEP 20

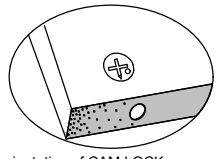
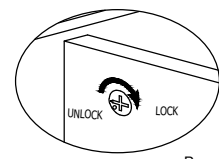
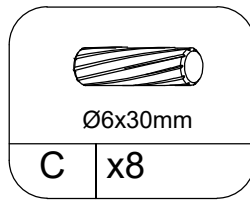
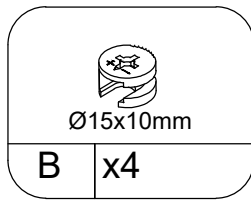
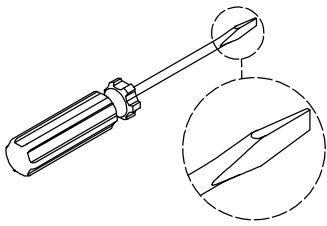

Proper orientation of CAM LOCK

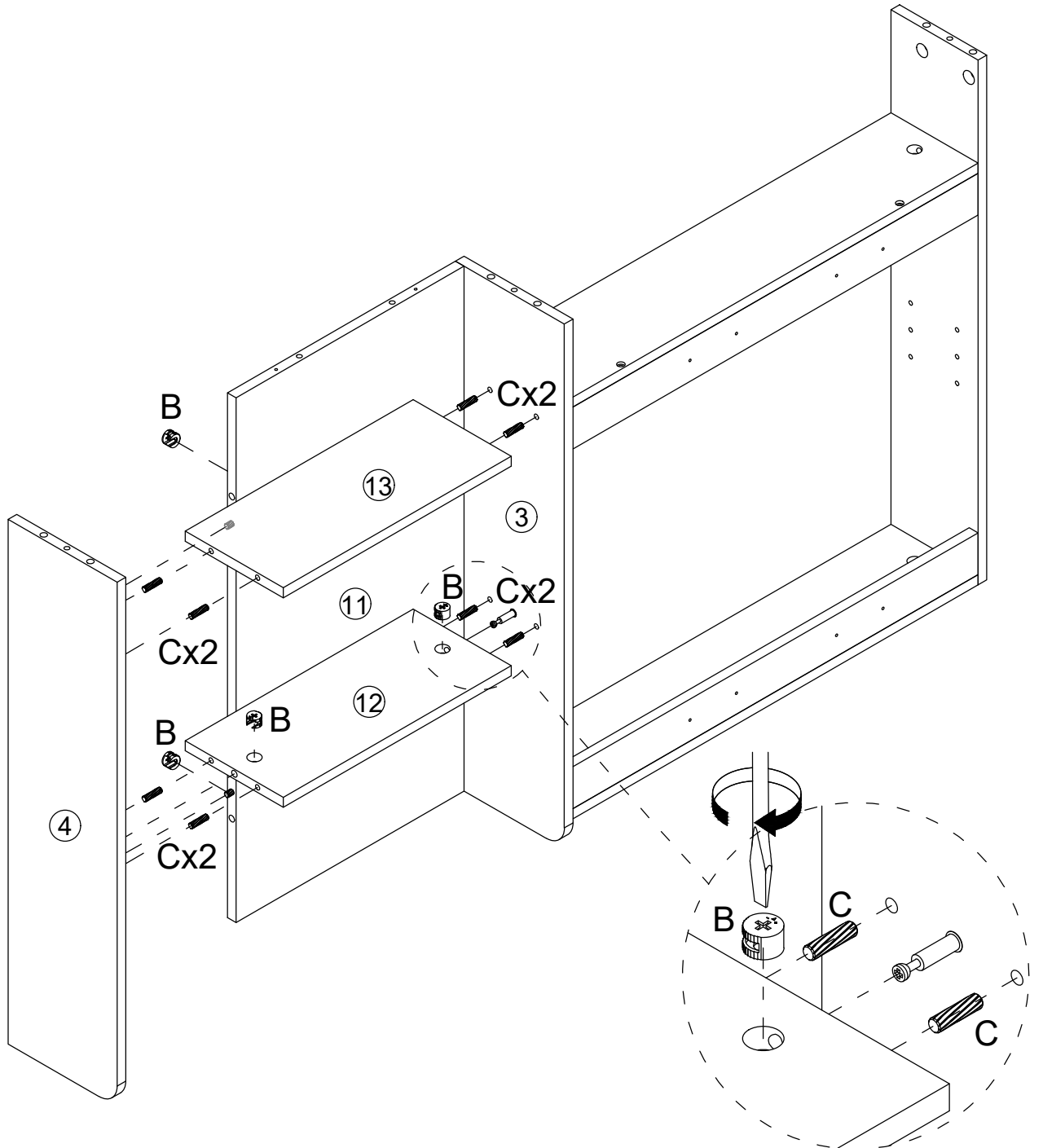

# STEP 21

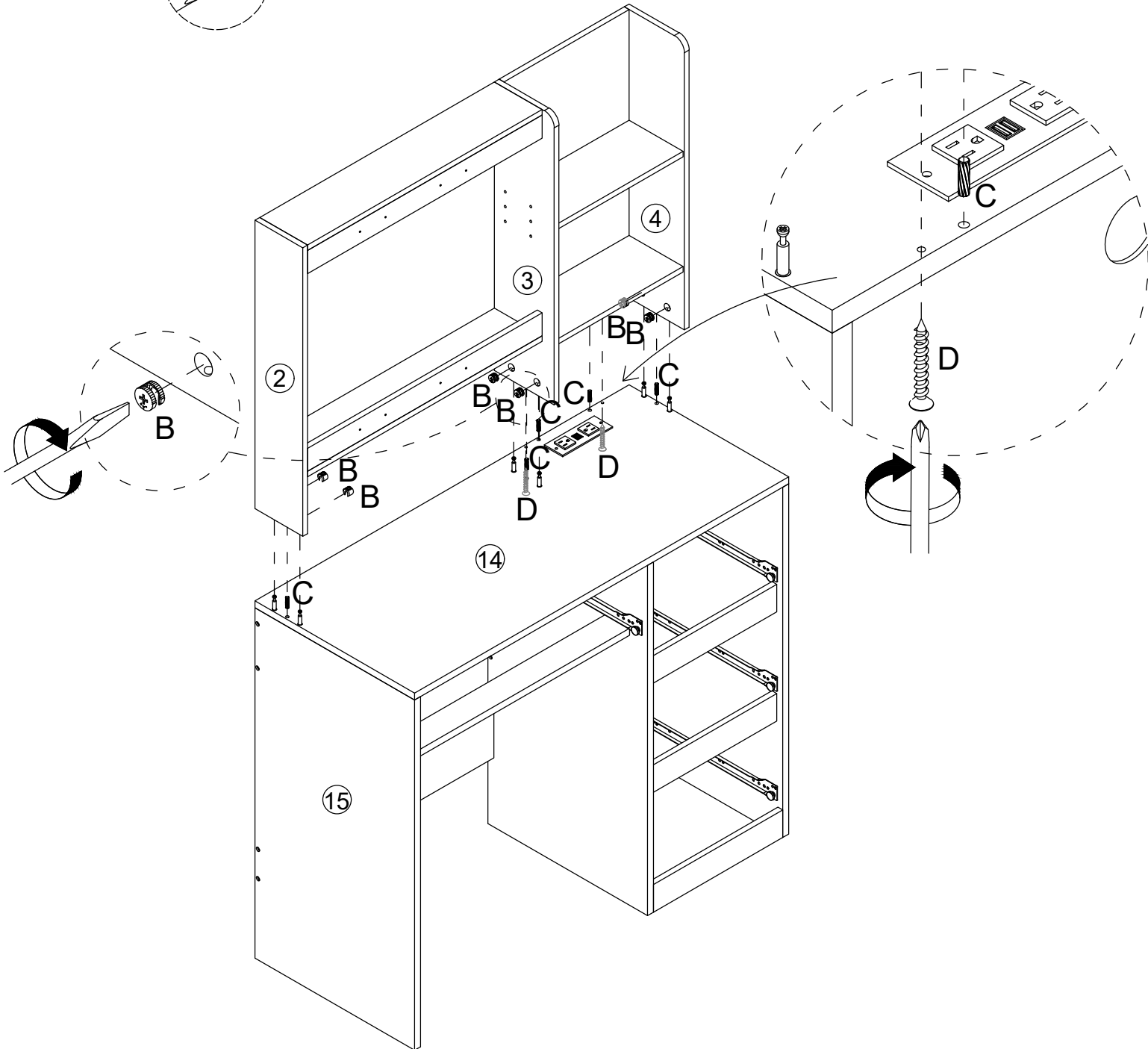
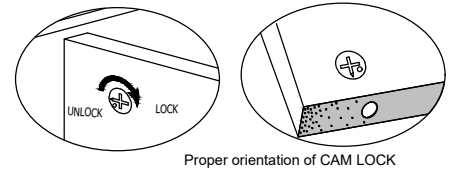
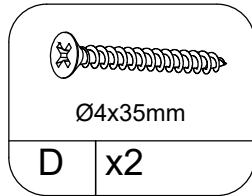
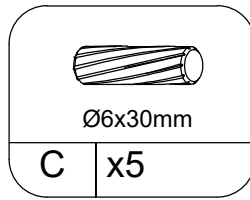
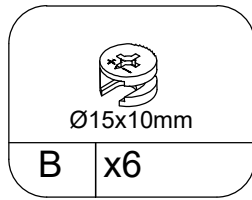
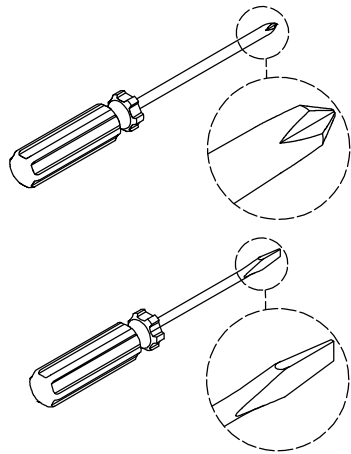

# STEP 22

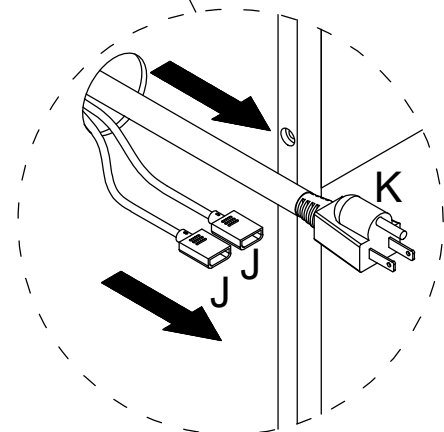
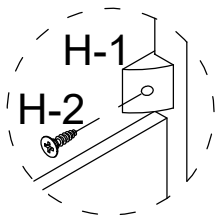
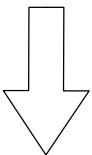
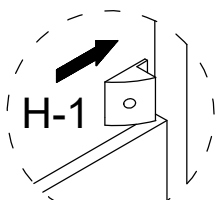
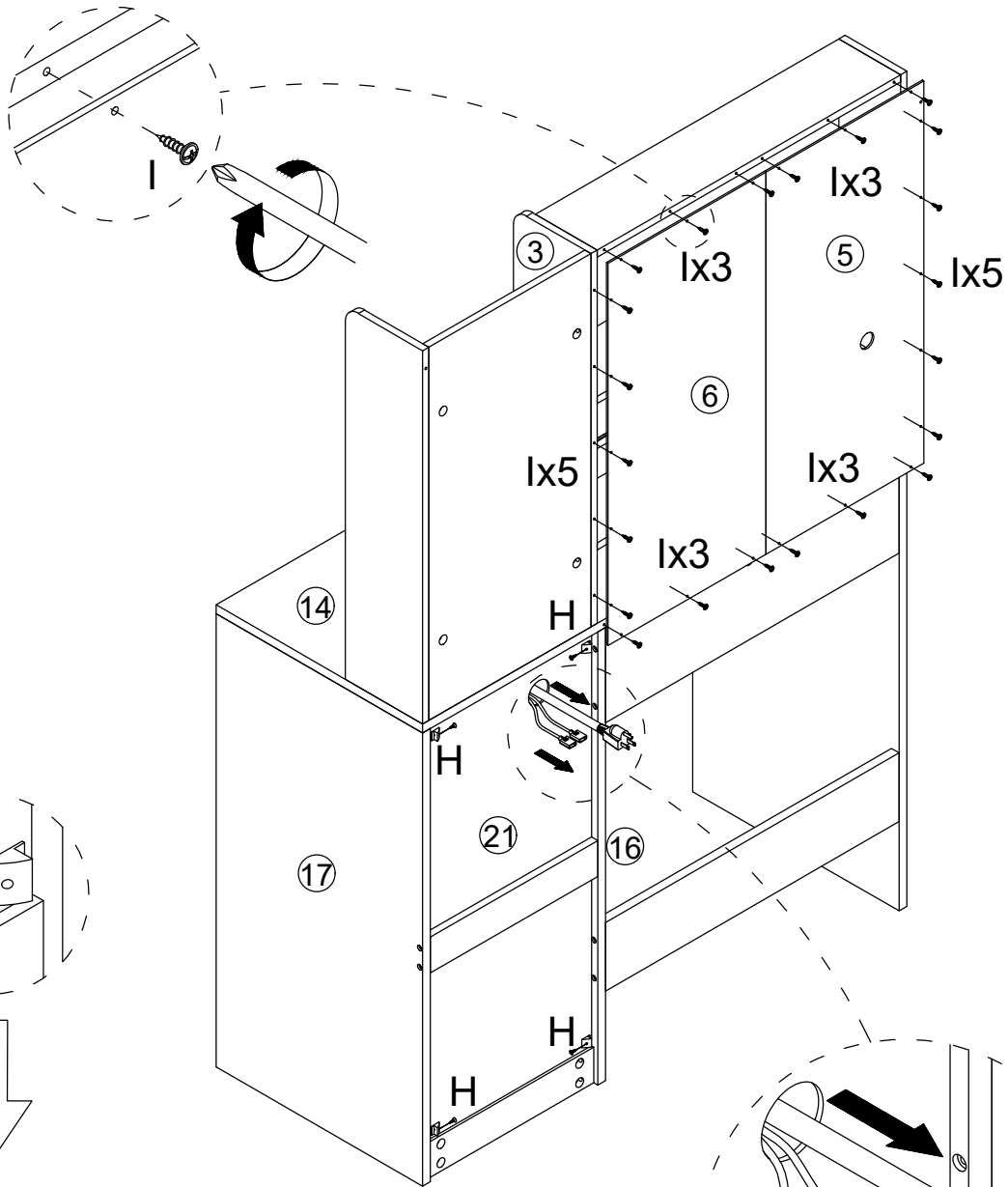
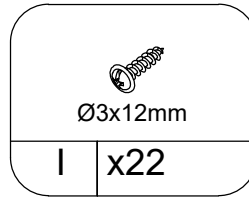
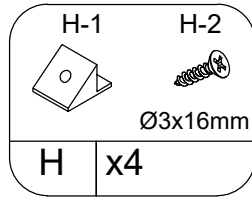
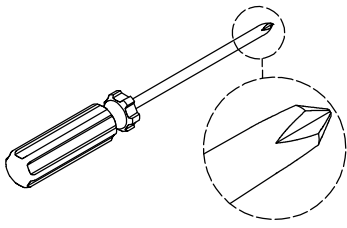



# STEP 23

---

## WARNING

### How To SEPARATE BALL BEARING SLIDE.

- 1) Pull toward arrow to open the slide until its stops and then flip it over.



- 2) Push plastic lever down and pull apart.

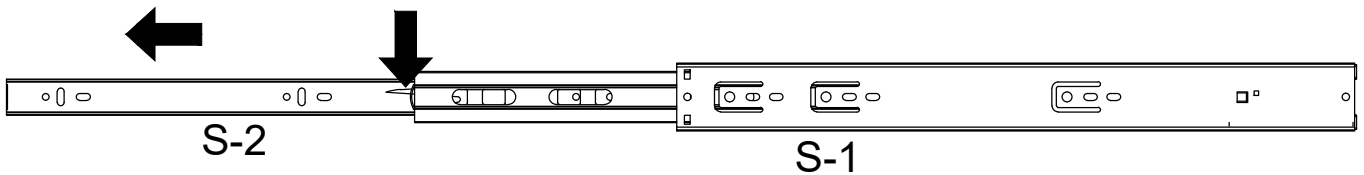

Cabinet member



Drawer member

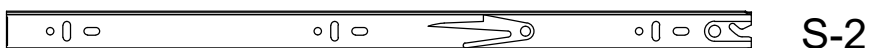

# STEP 24

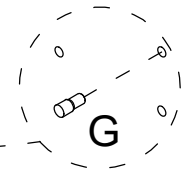
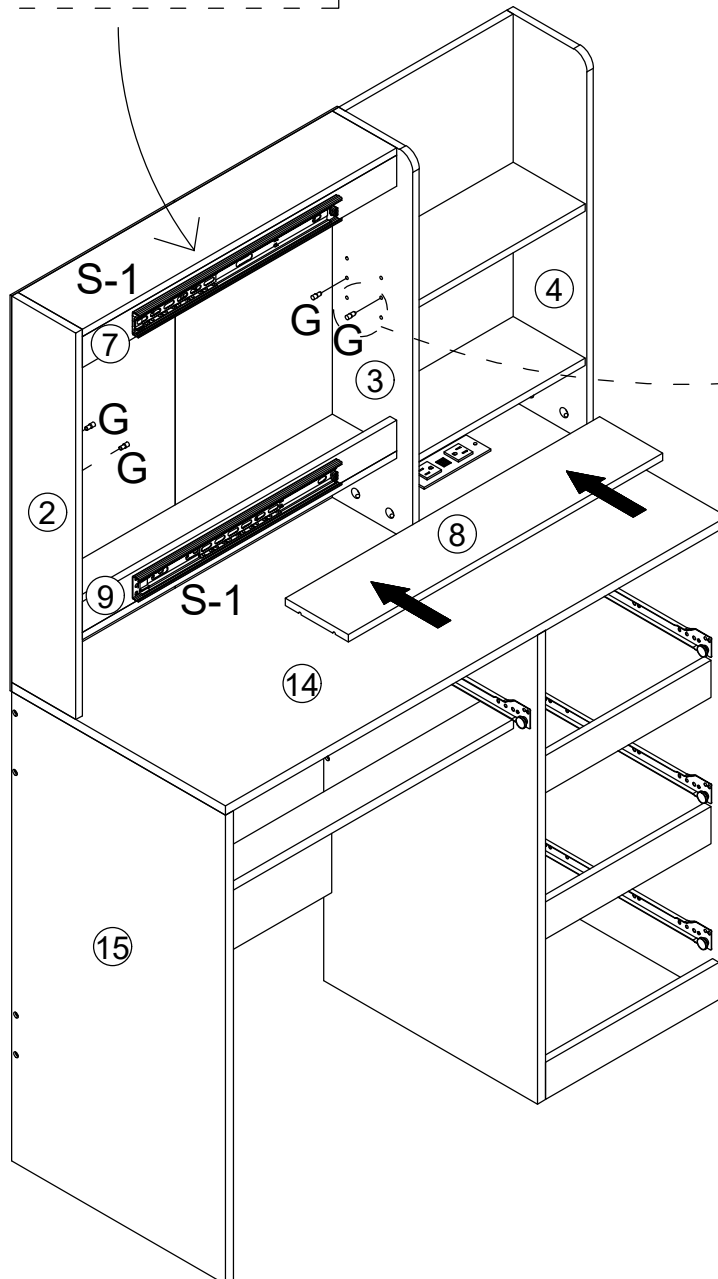
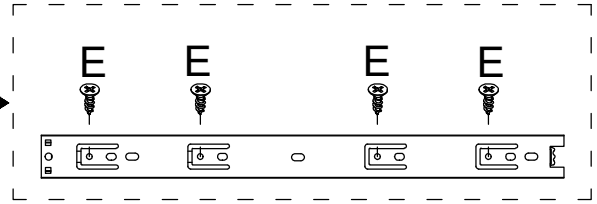
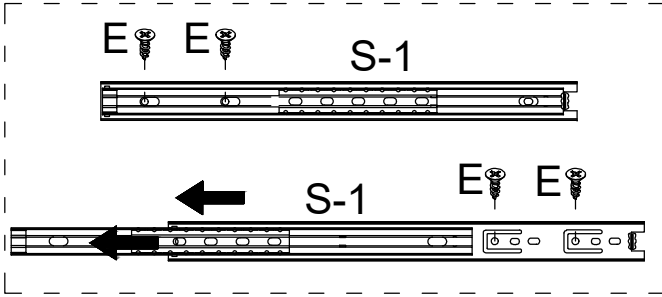
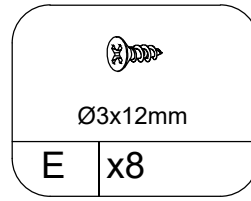
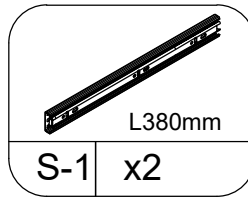
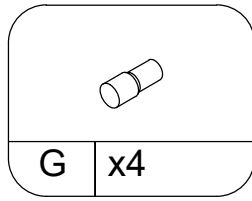
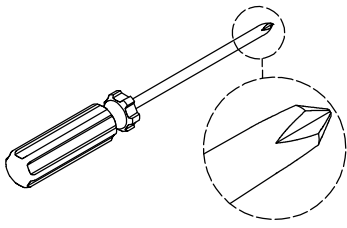

# STEP 25

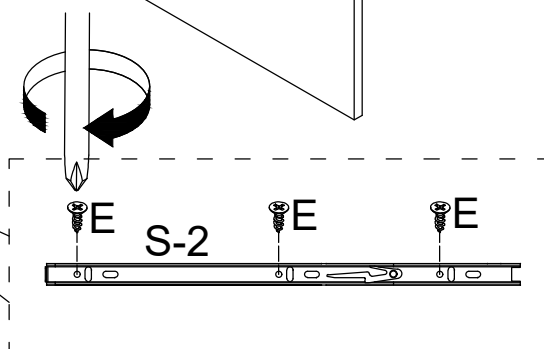
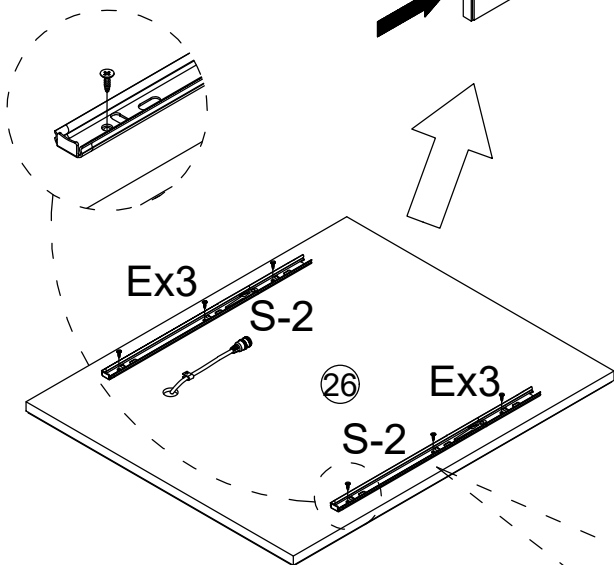
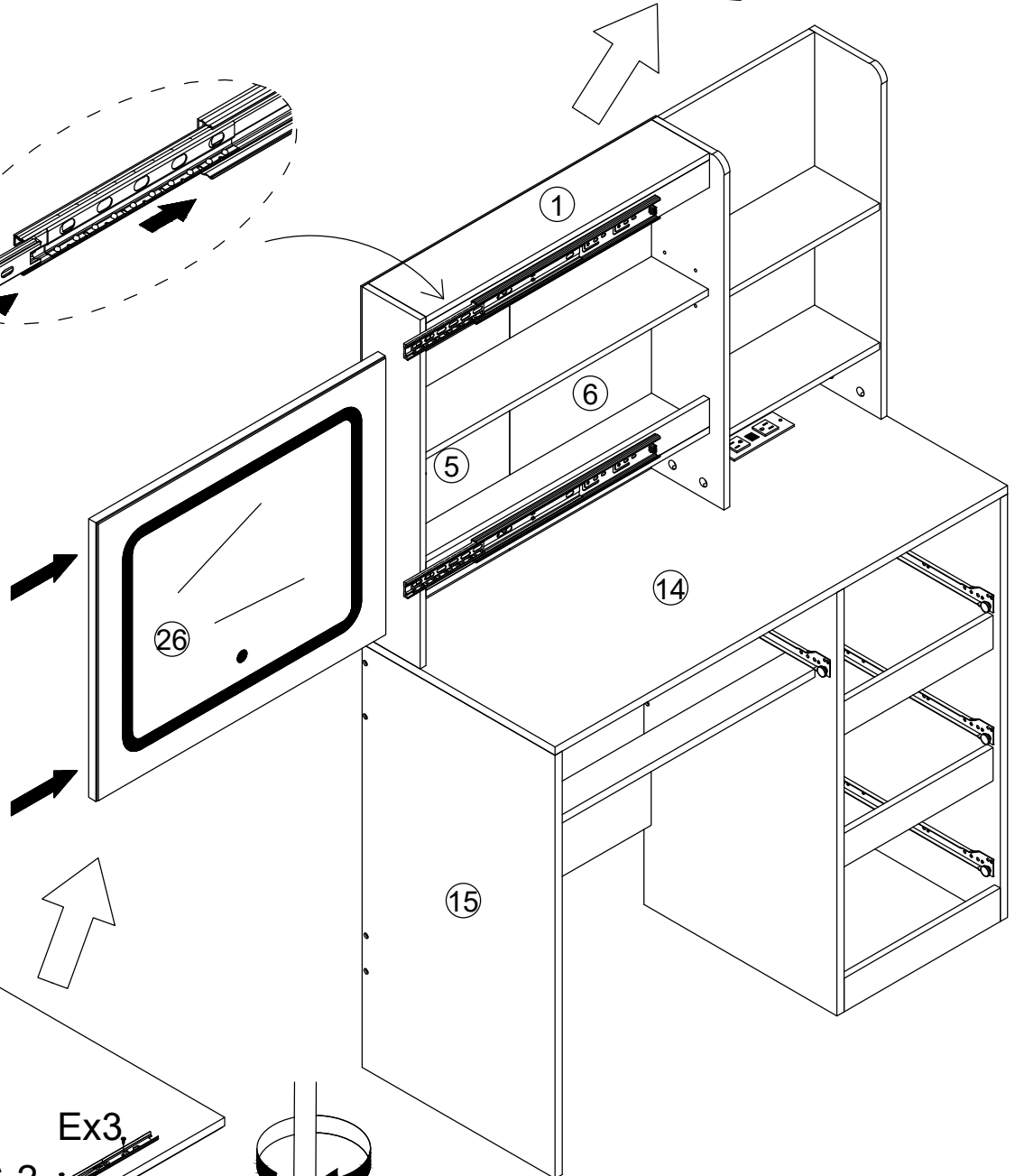
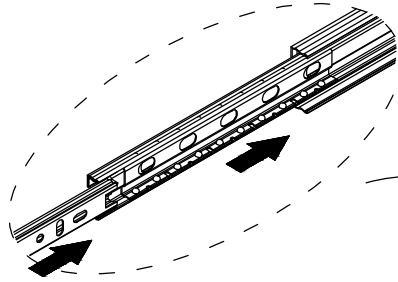
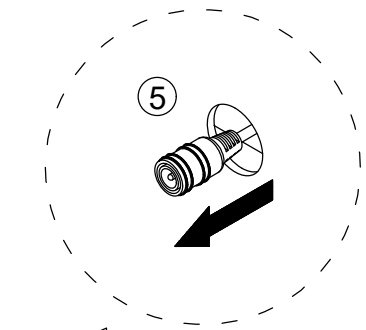
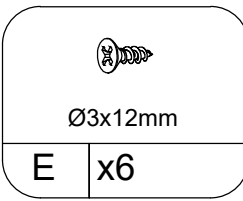
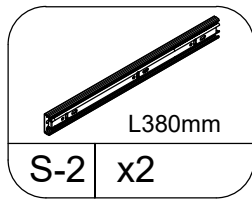
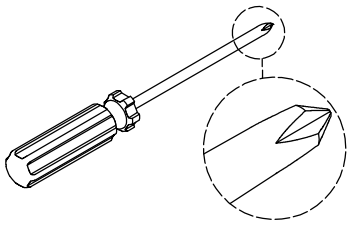

# STEP 26

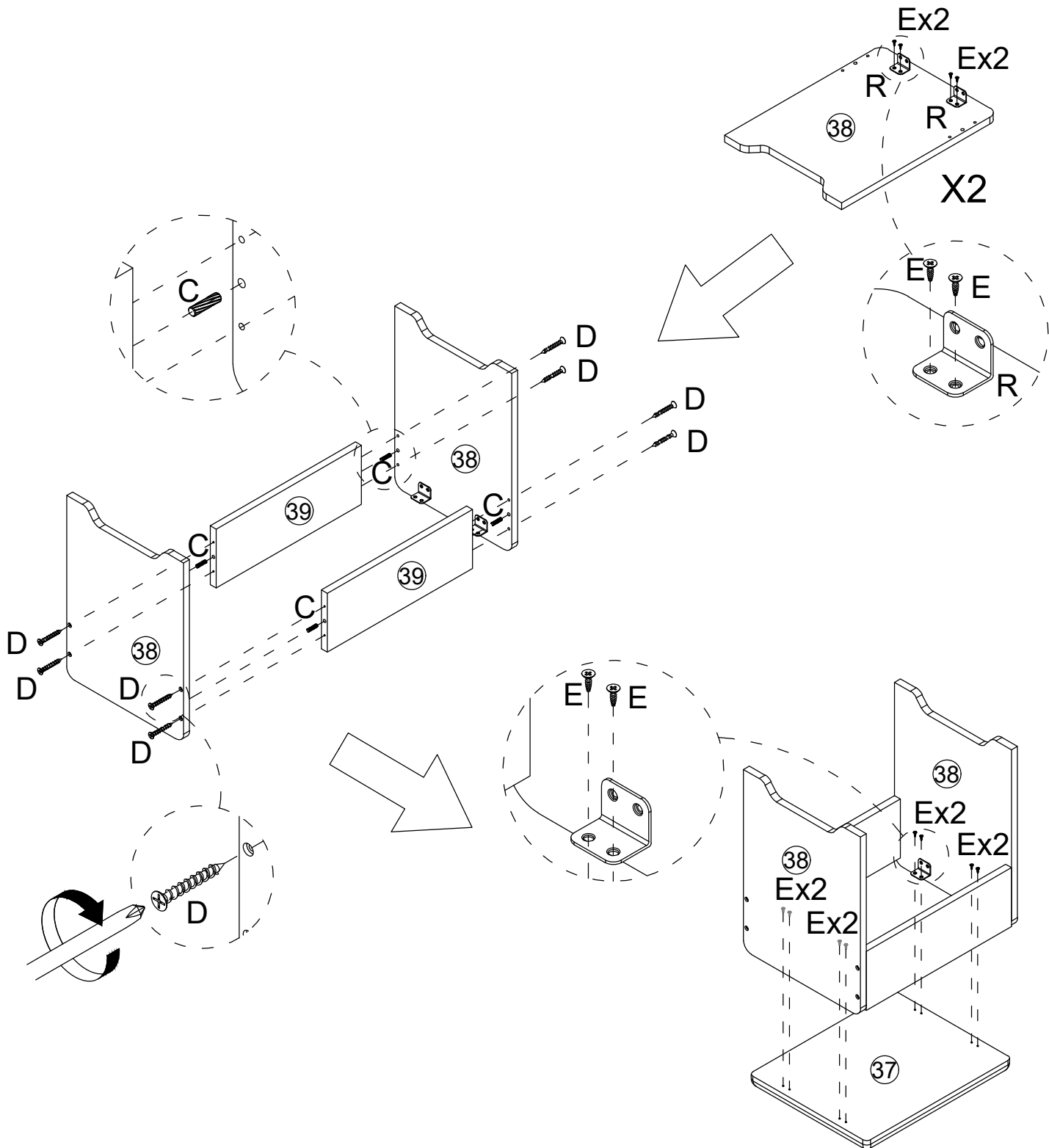
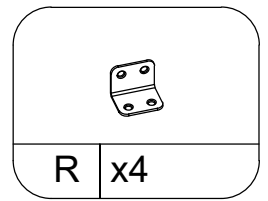
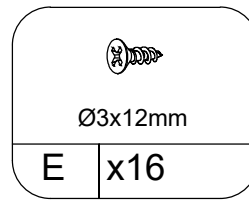
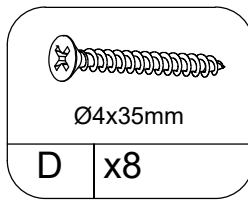
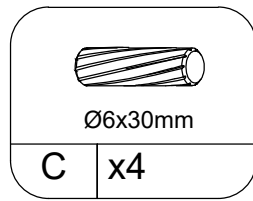
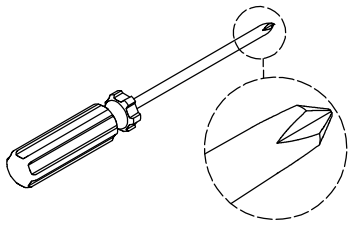

# STEP 27

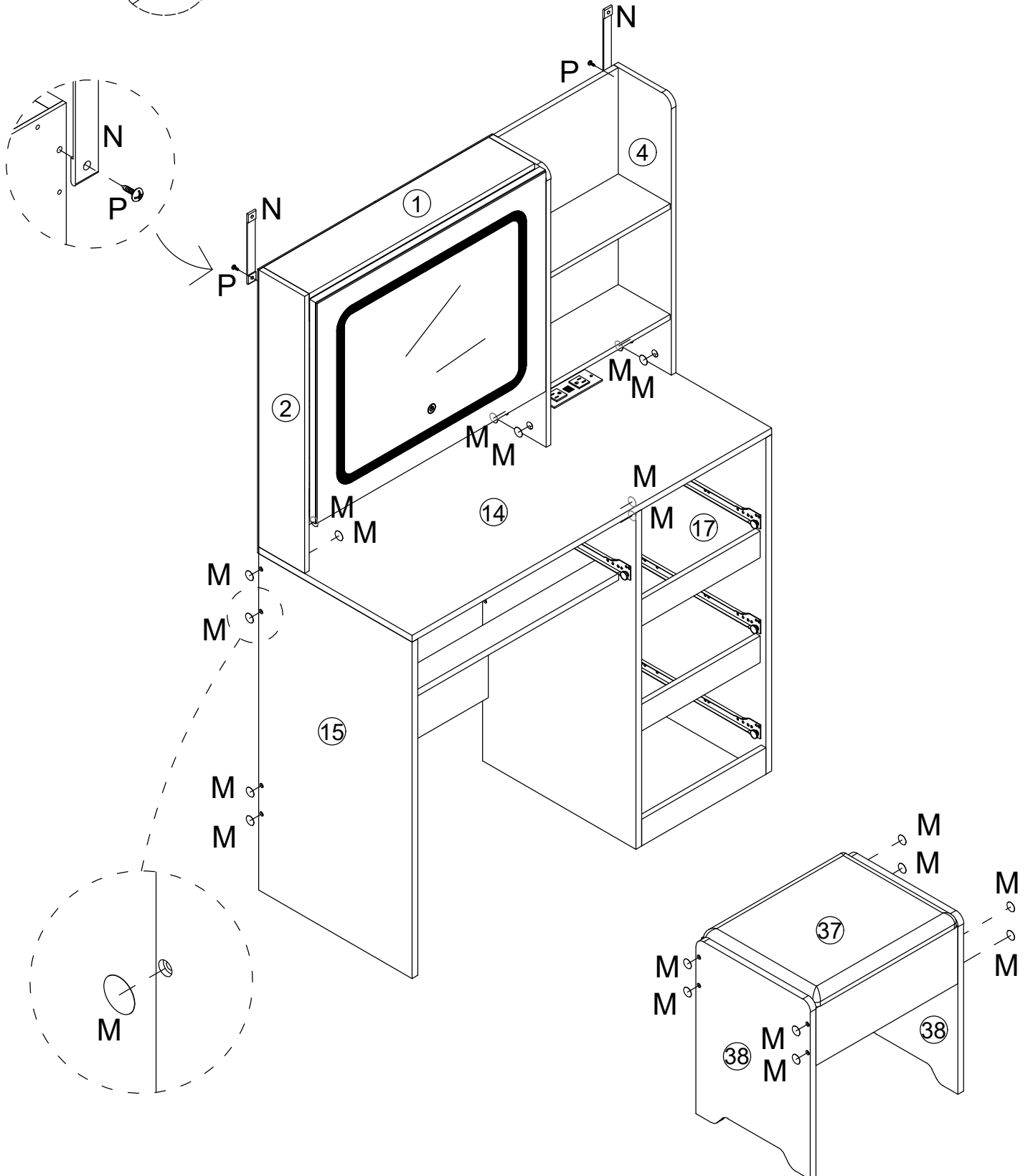
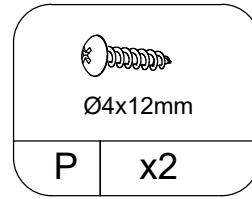
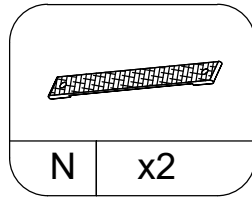
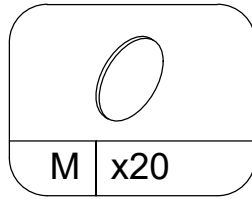
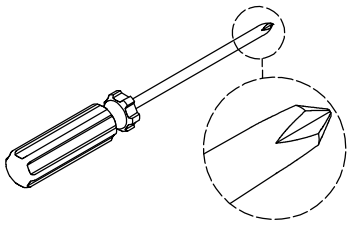

# STEP 28

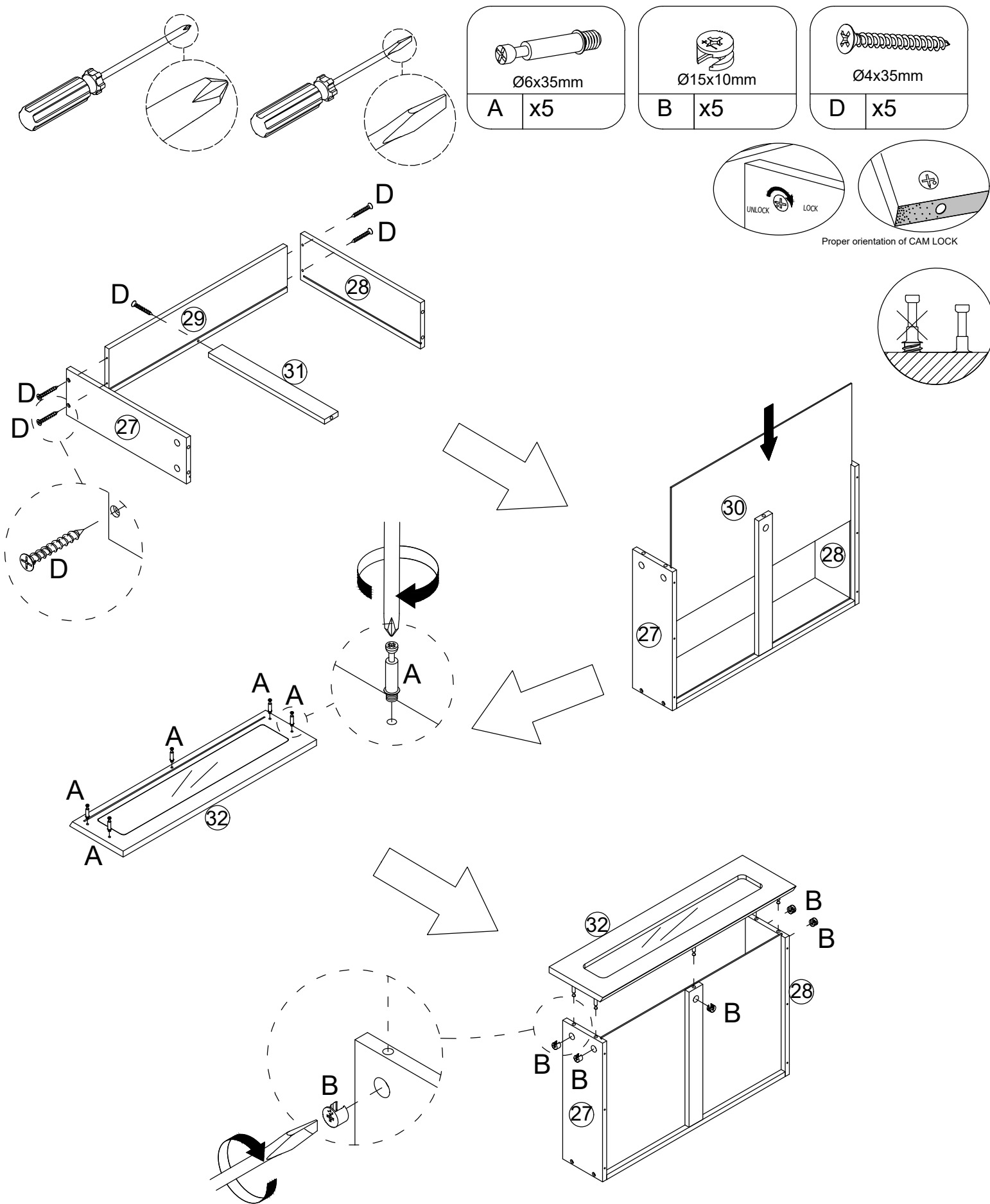

# STEP 29

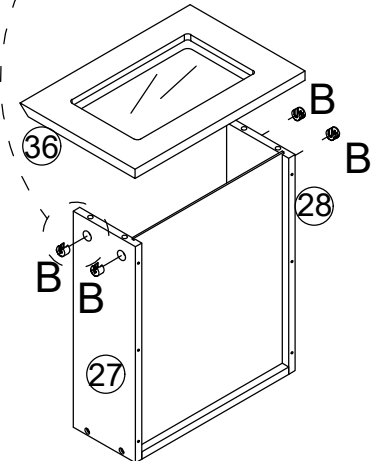
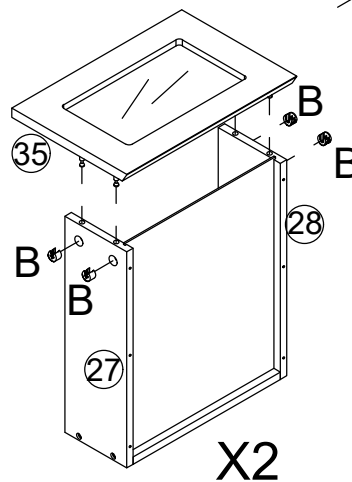
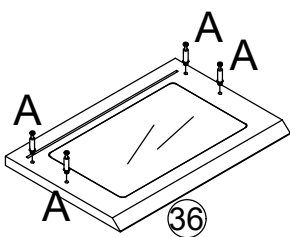
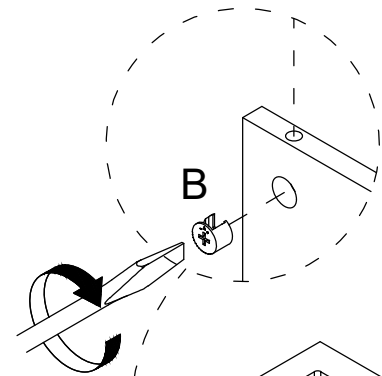
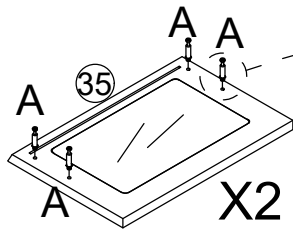
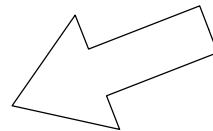
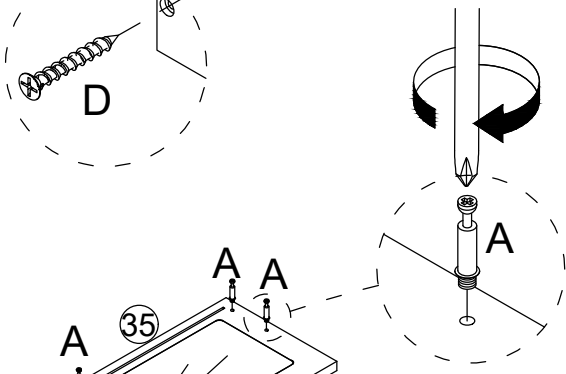
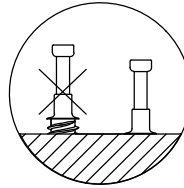
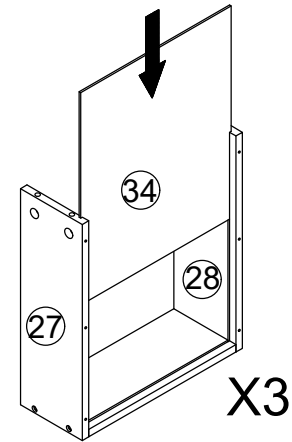
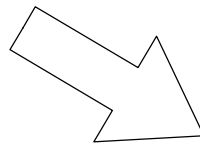
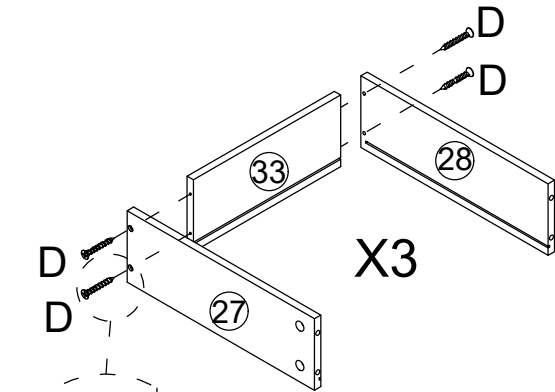
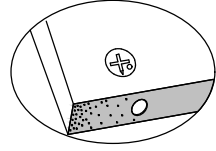
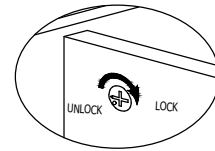
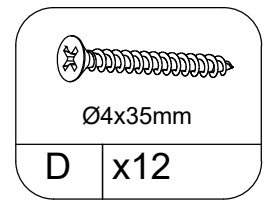
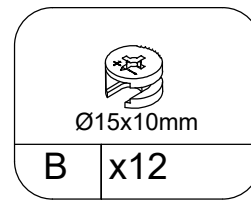
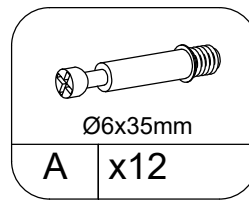
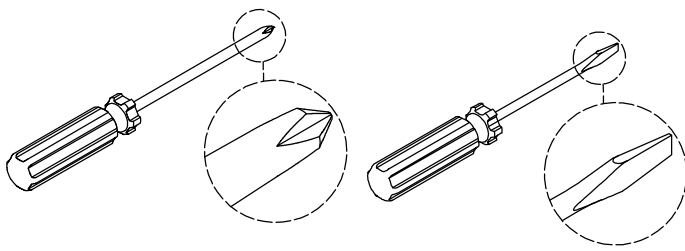

# STEP 30

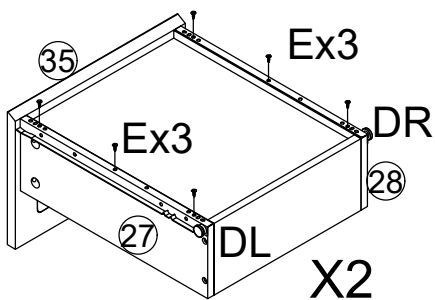
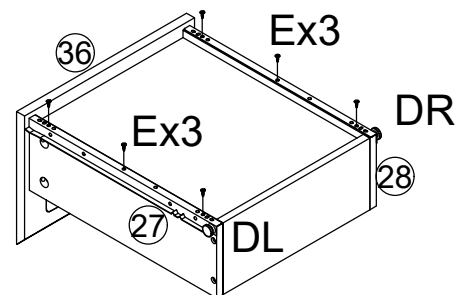
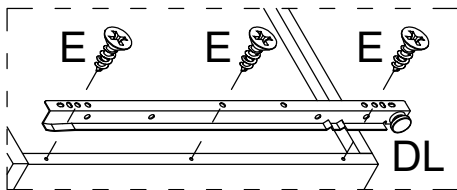
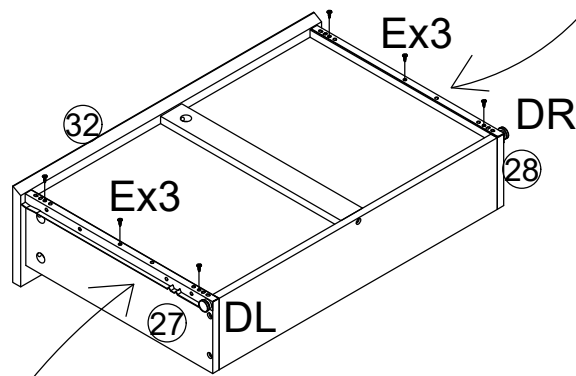
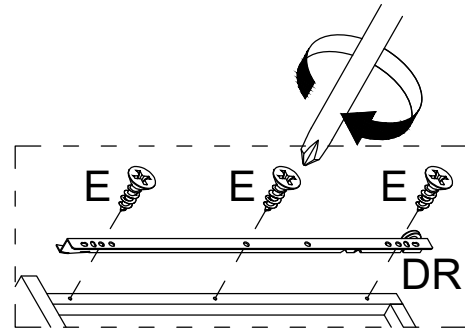
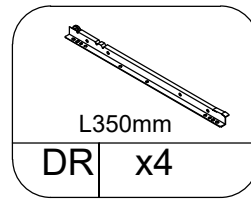
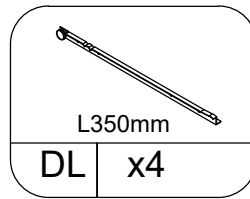
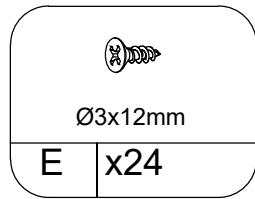
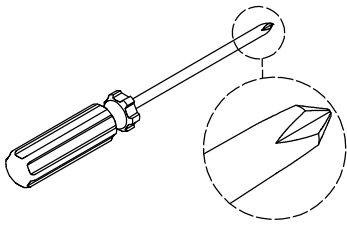



# STEP 31

---

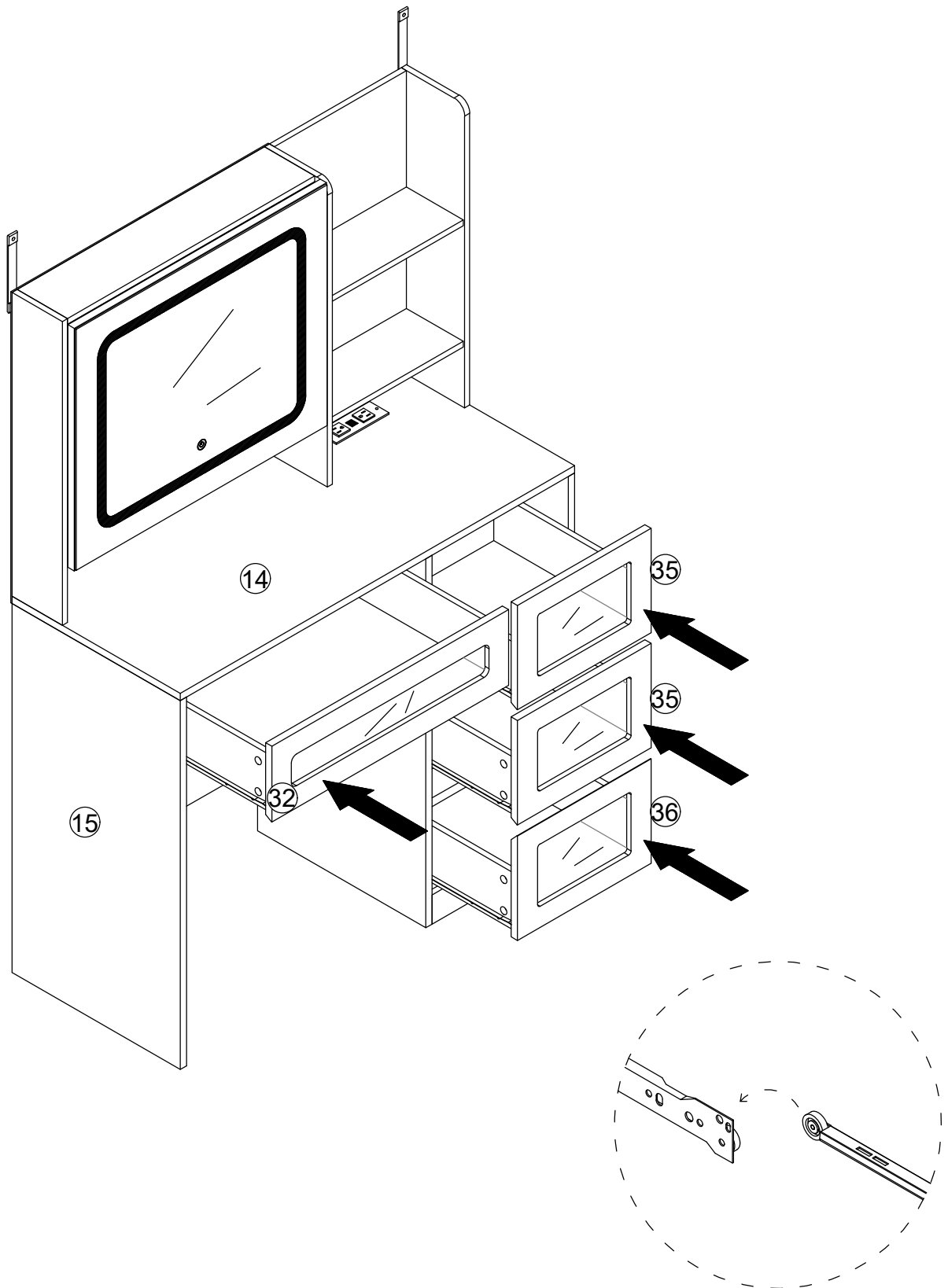

# STEP 32

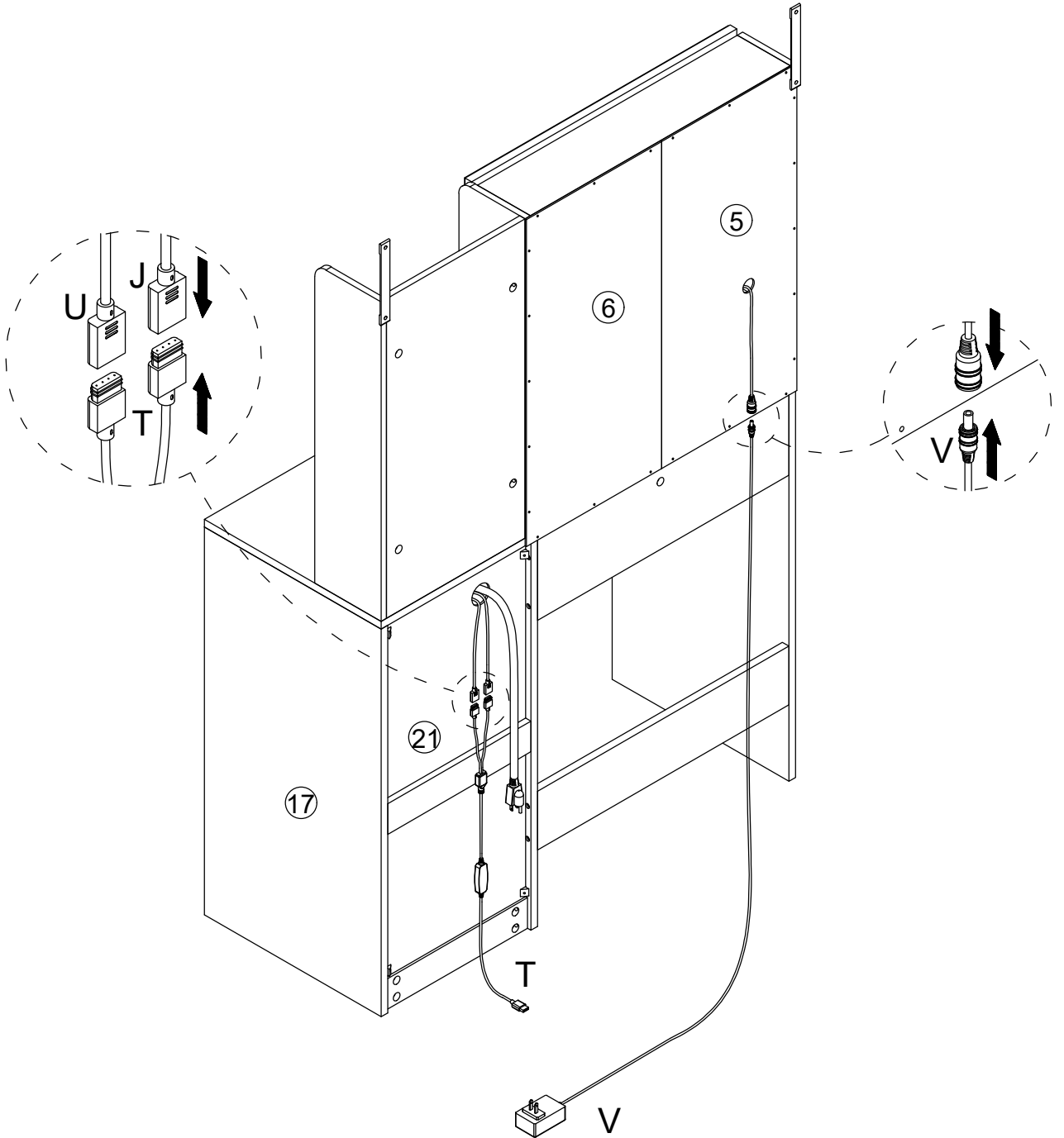
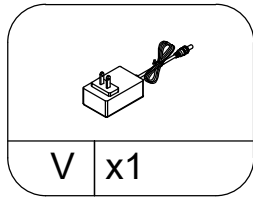
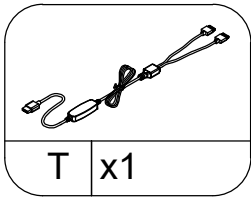

# STEP 33

