

As this item contains many parts, please read the installation instruction carefully before installation . Please use tools properly and carefully. If you have any questions about the product and installation, please contact us.

**service@vabchesofficial.com**

Our professional after-sales team will serve you online all day.

# Before You Start

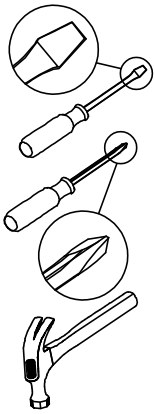

- ✓ Read through each step carefully and follow the proper order
- ✓ Separate and count all your parts and hardware
- ✓ Give yourself enough room for the assembly process
- ✓ Have the following tools: Flat Head Screwdriver, #2 Phillips Head Screwdriver and Hammer
- ✓ Caution: If using a power drill or power screwdriver for screwing, please be aware of to slow down and stop when screw is tight. Failure to do so may result in stripping the screw. (Assembly speed can be increased by using electric screwdriver)

# Helpful Hints



## PEOPLE NEEDED FOR ASSEMBLY: 1-2

- Open your item in the area you plan to keep it to avoid excessive heavy lifting.
- Identify, sort and count the parts before attempting assembly.
- Compression dowels are lightly tapped in with a hammer.
- Slides are labeled with an R (right) and L (left) for proper placement.
- Make sure to always face the point on the top of the Cam Lock towards the outer edge.
- If there is a back panel in the package, please install it to make sure your unit is complete and sturdy.
- Please fix all the screws provided for the back panel which can enhance product stability. If it is difficult to fix it when tightening, it can be fixed with the help of a hammer and then tightened.
- Do NOT use harsh chemicals or abrasive cleaners on this item.
- Never push, pull, or drag your furniture.



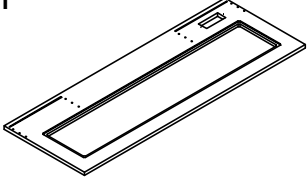
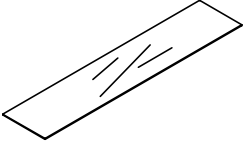
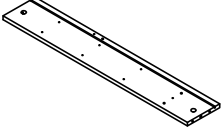
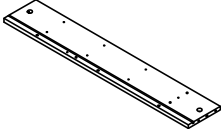
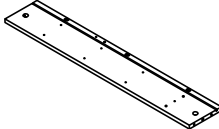
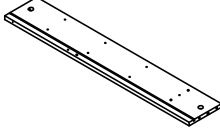
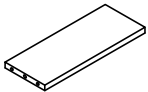
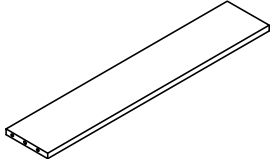
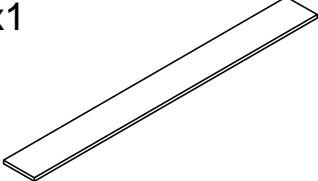
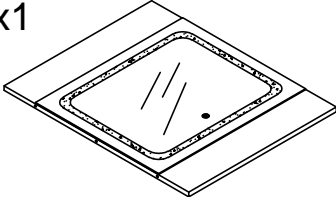
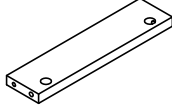
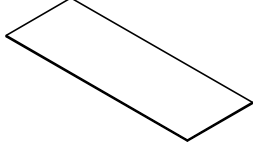

# Board Identification

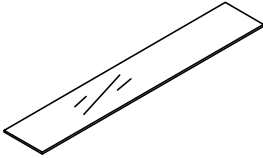
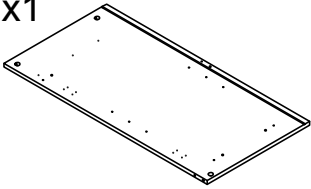
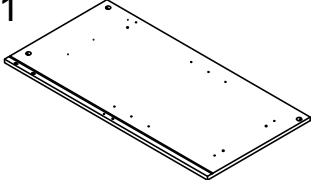
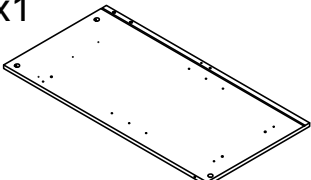
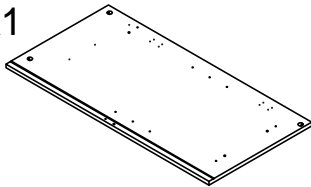
Not actual size

①x1 	②x1 	③x1 
Panel	Panel glass	Upper left panel
④x1 	⑤x1 	⑥x1 
Upper and middle partition	Upper and middle partition	Upper right panel
⑦x2 	⑧x1 	⑨x1 
Upper left and right layer boards	Upper and middle layer board	Top plate
⑩x1 	⑪x6 	⑫x2 
Mirror	Back brace	Upper back plate
⑬x6 	⑭x1 	⑮x1 
Left and right glass laminates	Medium glass laminate	Lower left side
⑯x1 	⑰x1 	⑱x1 
Left cabinet right board	Left panel of right cabinet	Right side panel

# Board Identification

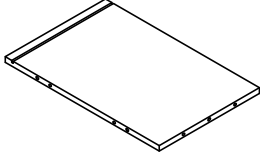
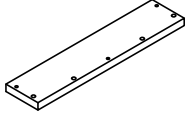
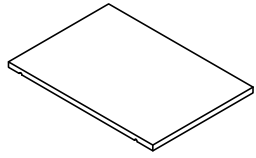
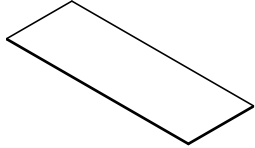
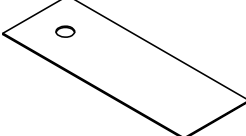
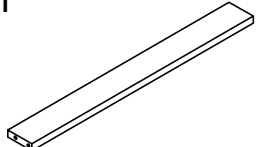
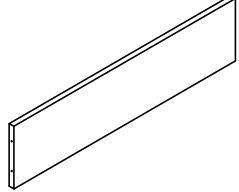
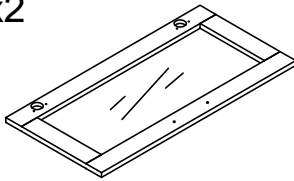
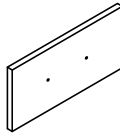
Not actual size

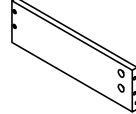
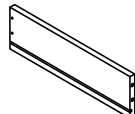
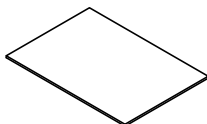
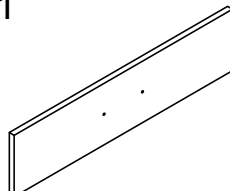
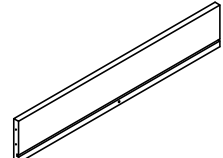
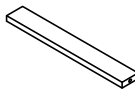
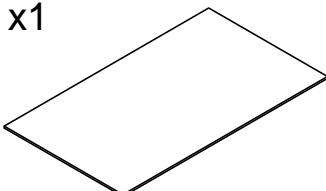
<p>①9 x2</p> 	<p>②0 x2</p> 	<p>②1 x2</p> 
Lower left cabinet bottom plate	Skirting board	Lower activity layer board
<p>②2 x1</p> 	<p>②3 x1</p> 	<p>②4 x1</p> 
Left lower cabinet back panel	Lower right cabinet back panel	Bottom cabinet front brace
<p>②5 x1</p> 	<p>②6 x2</p> 	<p>②7 x2</p> 
Bottom cabinet rear upper brace	Glass door panel	Small drawer panel
<p>②8 x2</p> 	<p>②9 x3</p> 	<p>③0 x3</p> 
Small drawer back panel	Drawer left panel	Drawer right panel
<p>③1 x2</p> 	<p>③2 x1</p> 	<p>③3 x1</p> 
Small drawer bottom plate	Large drawer panel	Rear panel of large drawer
<p>③4 x1</p> 	<p>③5 x1</p> 	
Bottom strip of large drawer	Large drawer base plate	

# Part List

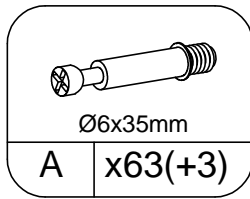

Cam Bolt

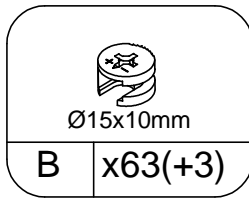

Cam Lock

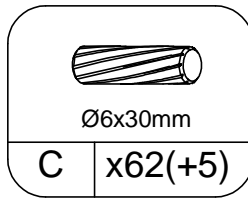

Dowel

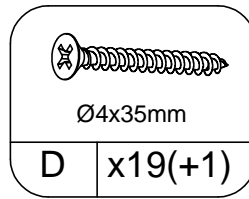

Flat Head  
Tapping Screw

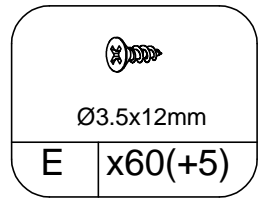

Sliding Track Screw

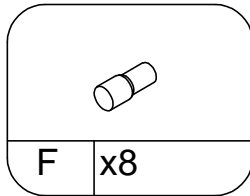

Lamina Torus

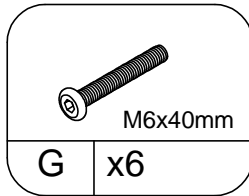

Cross bolt

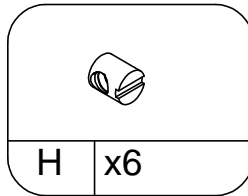

Vertical nut

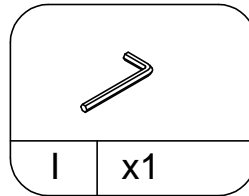

Hexagon Socket  
Handle

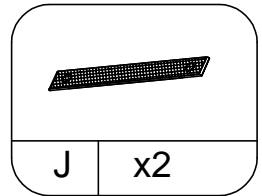

Anti-Fall Strip

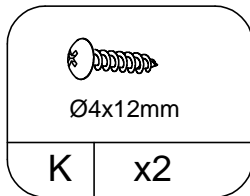

Round head screw

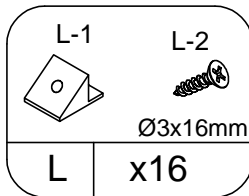

Back Buckle  
and screw

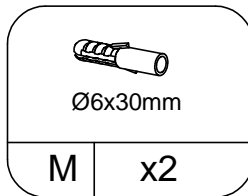

Plastic Expansion

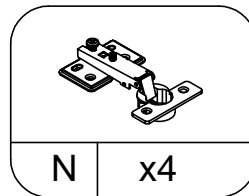

Hinge

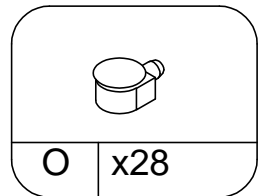

Glass suction cup

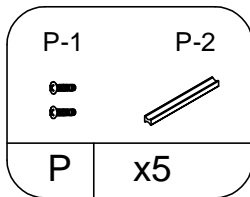

Handle screw  
and handle

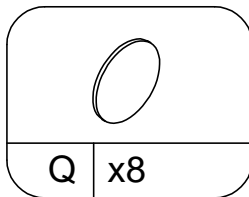

Hole sticker

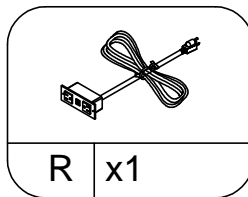

Socket

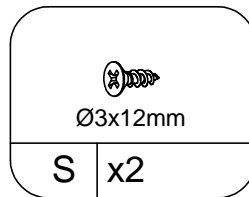

Screw

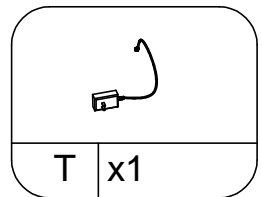

Power Supply

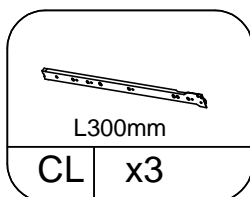

Sliding Track

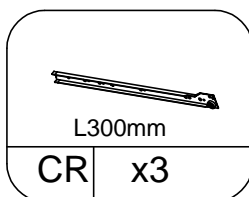

Sliding Track

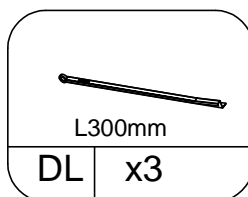

Sliding Track

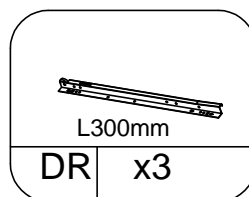

Sliding Track

# Part List

## Cam Lock Fastening System

Insert the cam bolt into the hole first, then insert the cam lock and lock it.

1

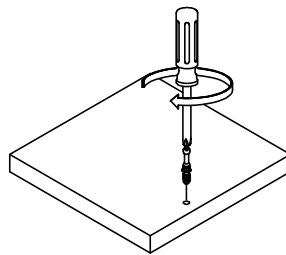

2

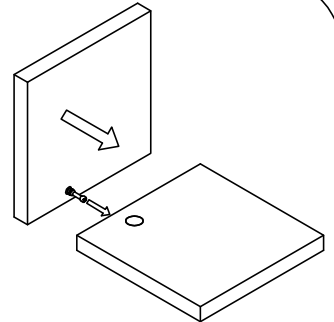

3

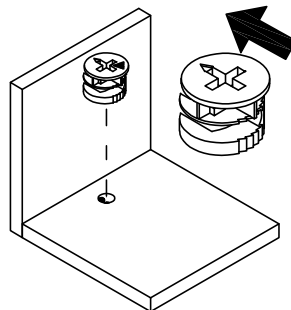

The opening must point toward the edge of the board

4

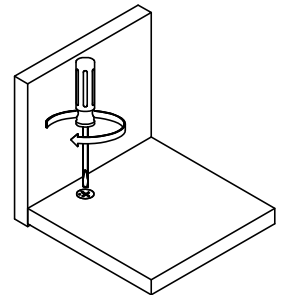

# Board Identification

Not actual size

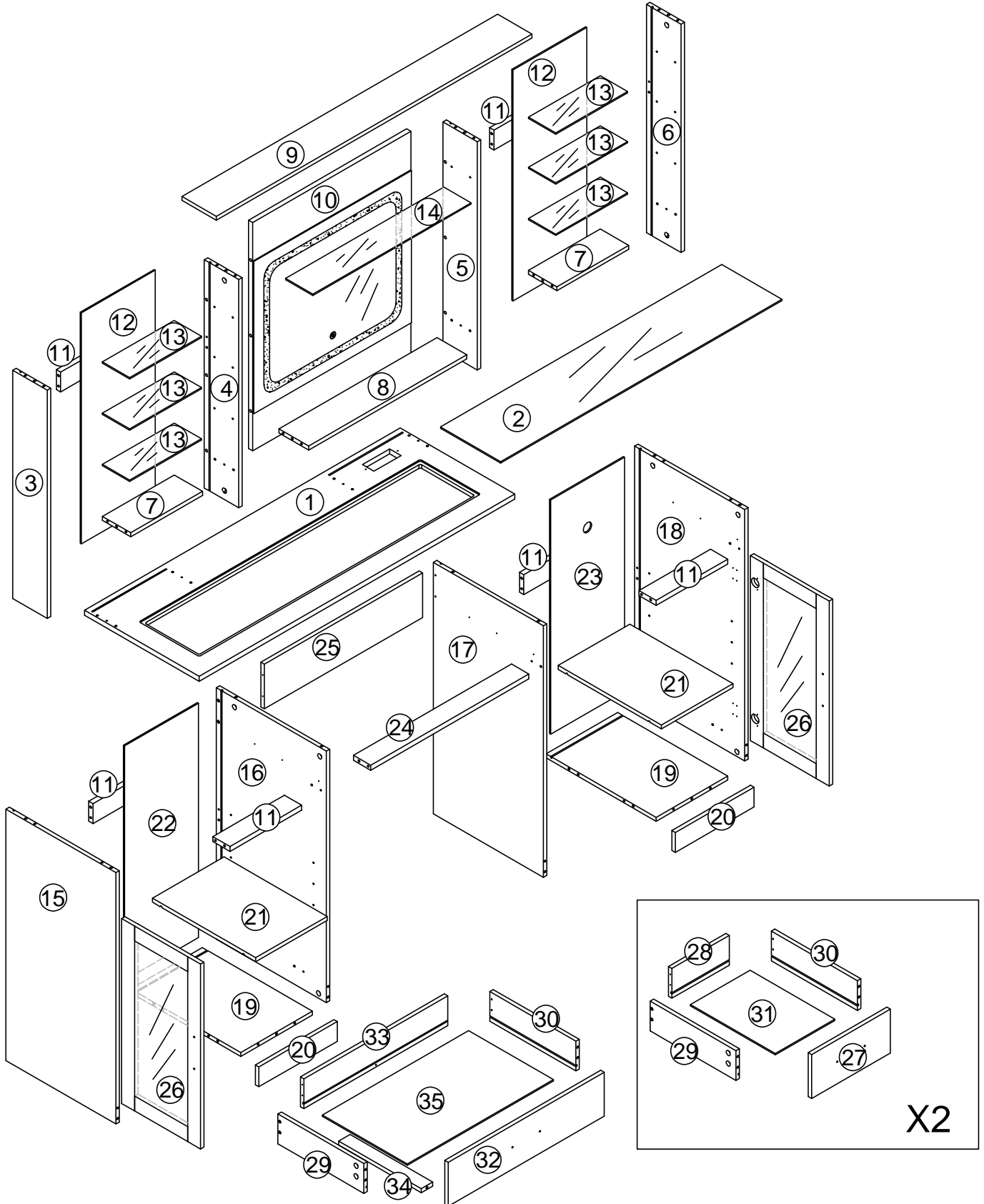

# STEP 1

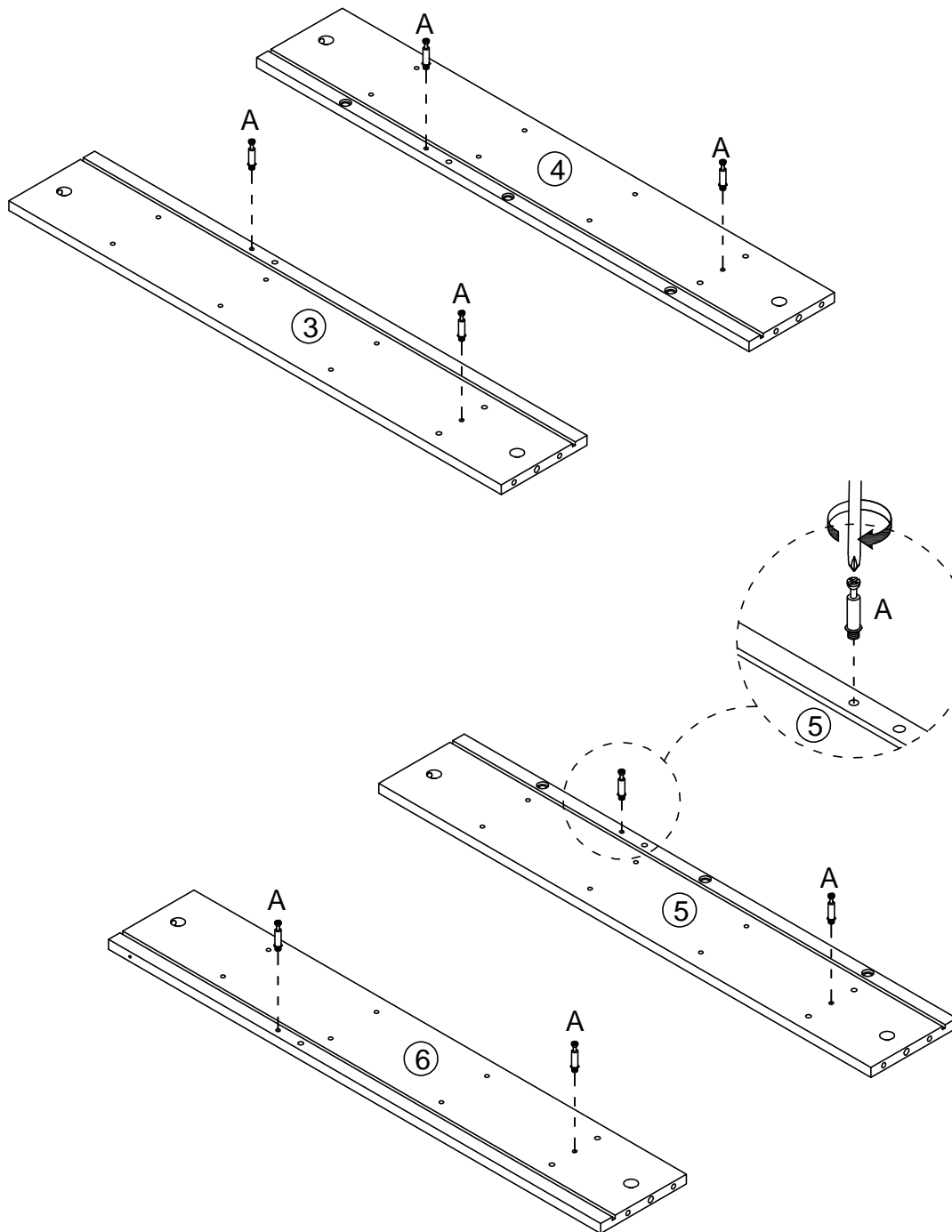
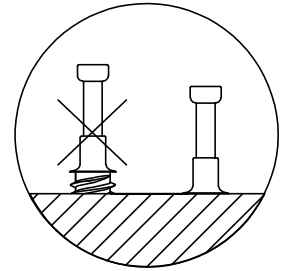
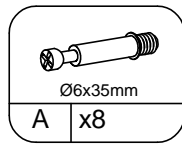
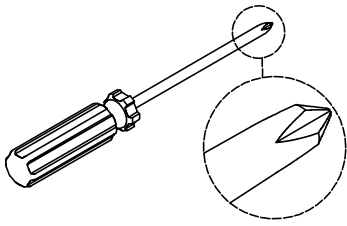



# STEP 2

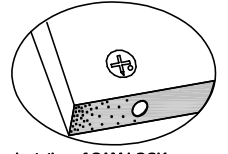
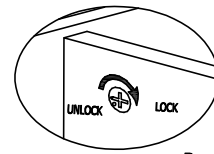
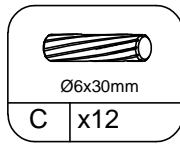
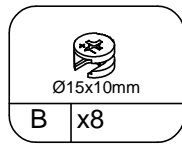
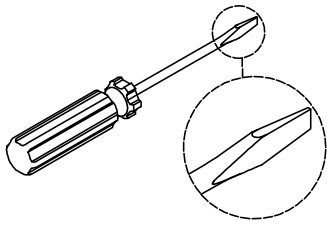

Proper orientation of CAM LOCK

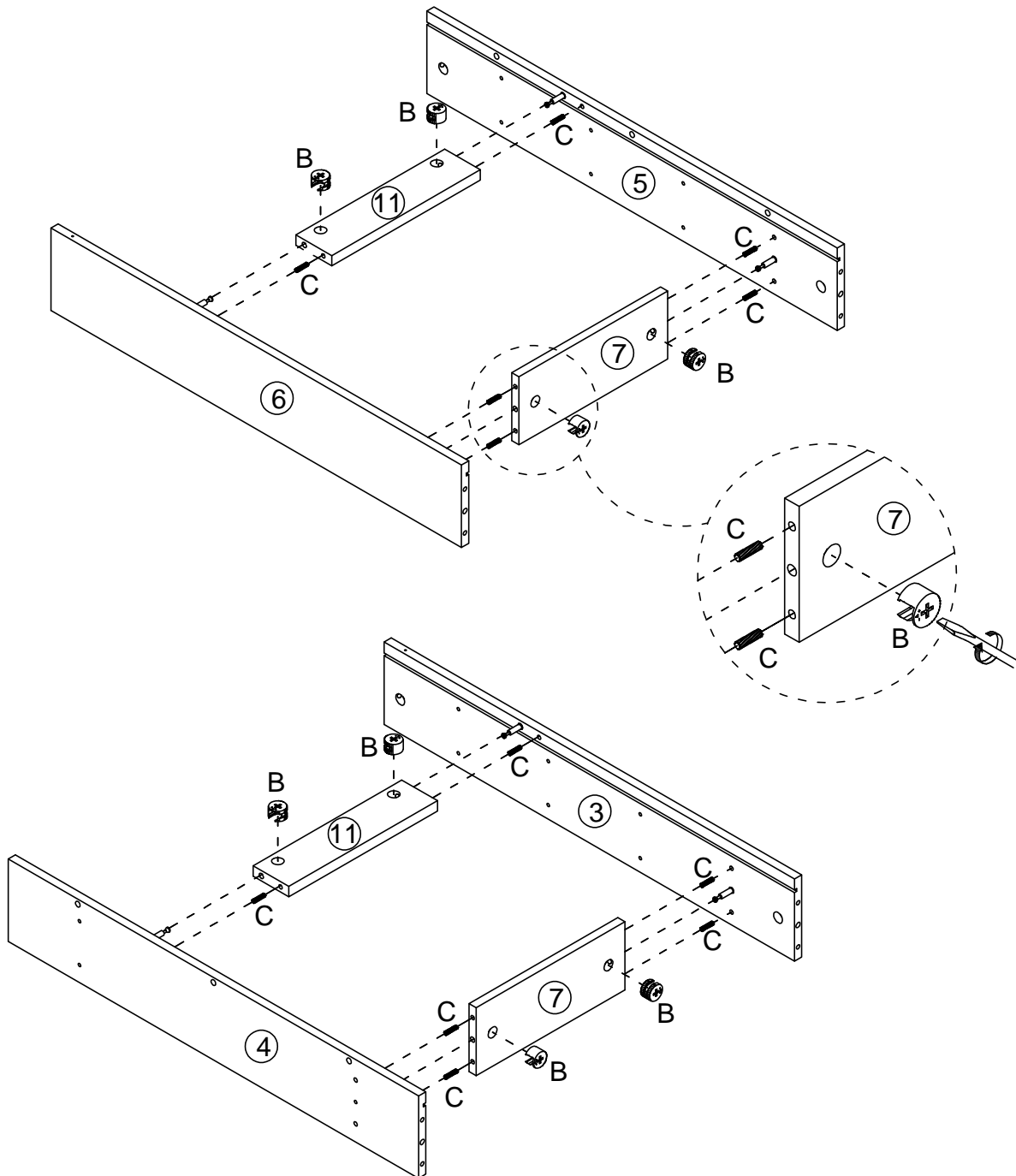

# STEP 3

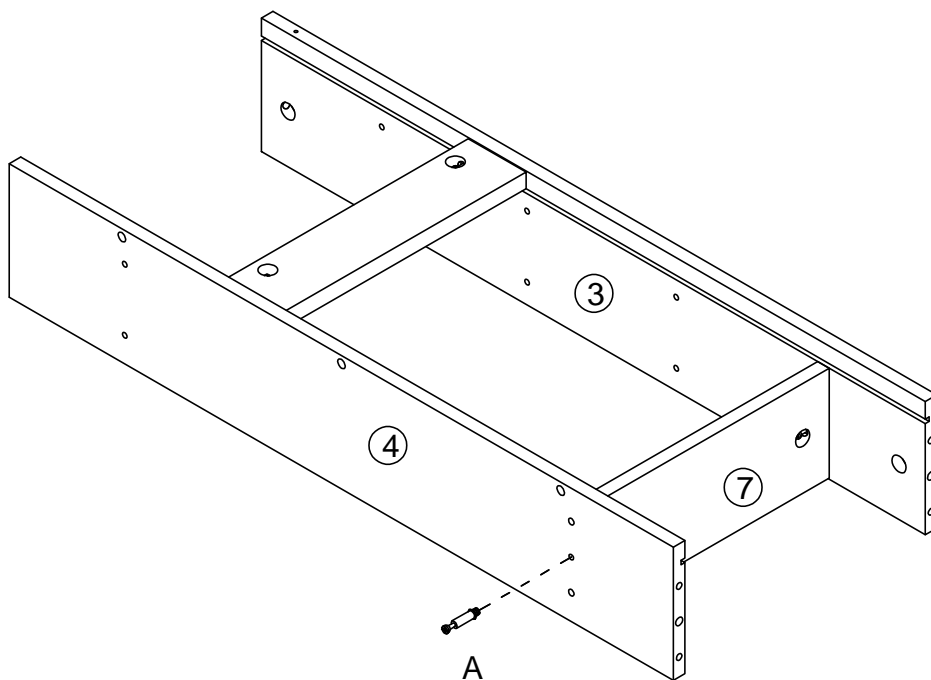
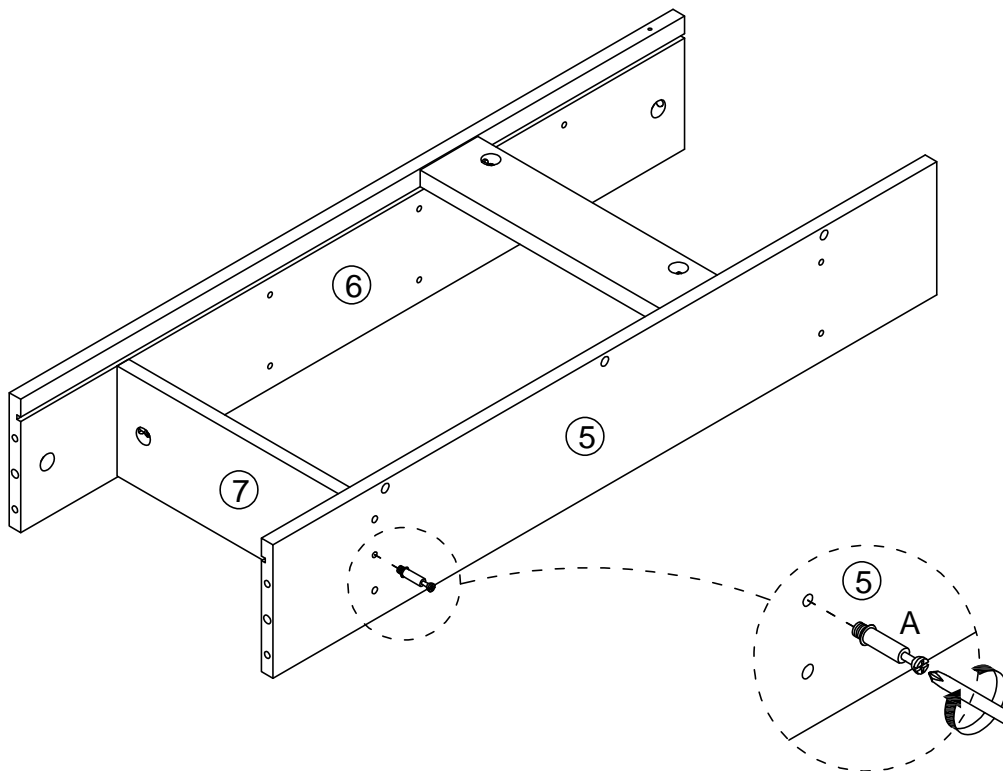
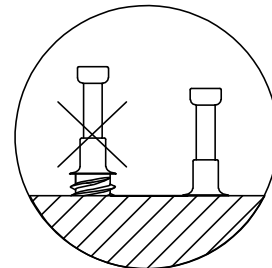
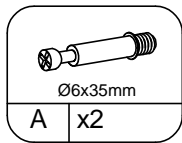
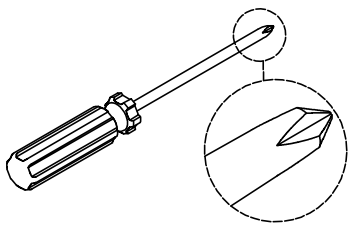

# STEP 4

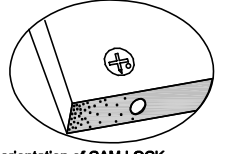
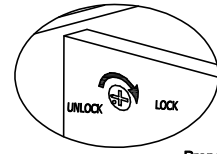
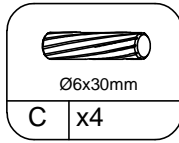
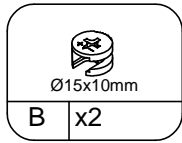
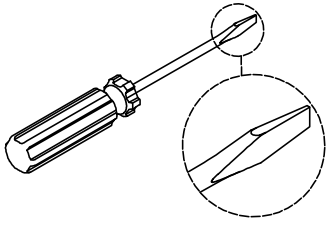

Proper orientation of CAM LOCK

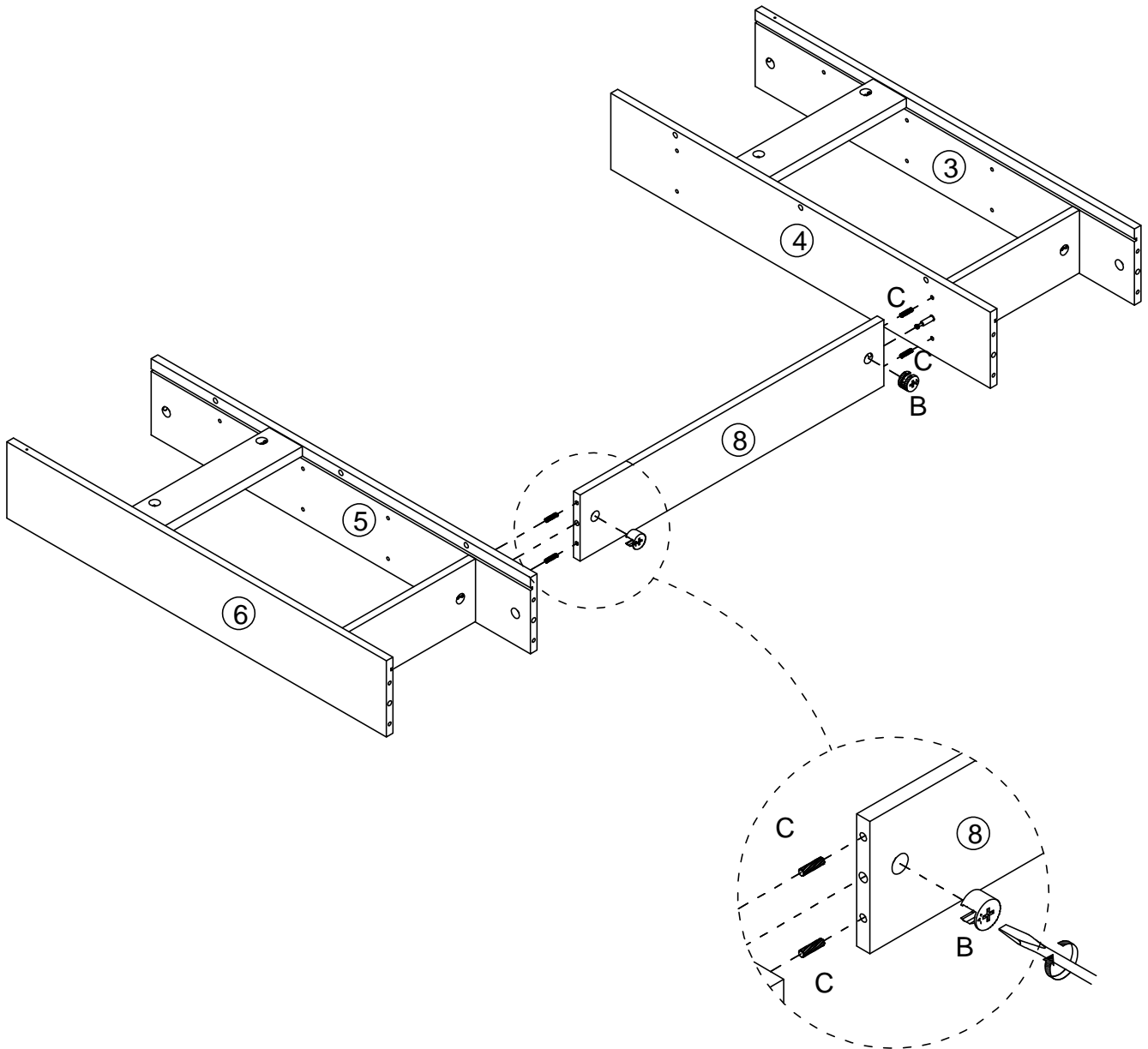

# STEP 5

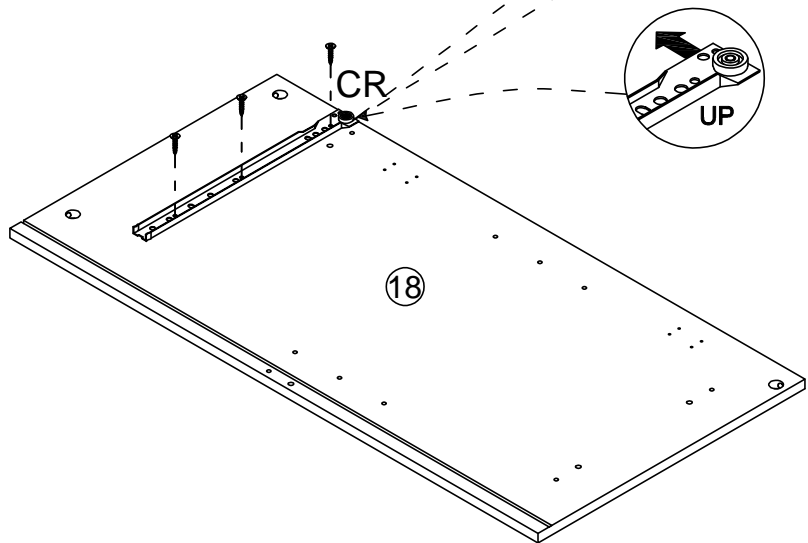
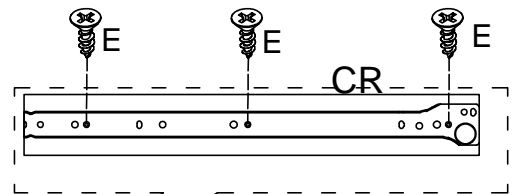
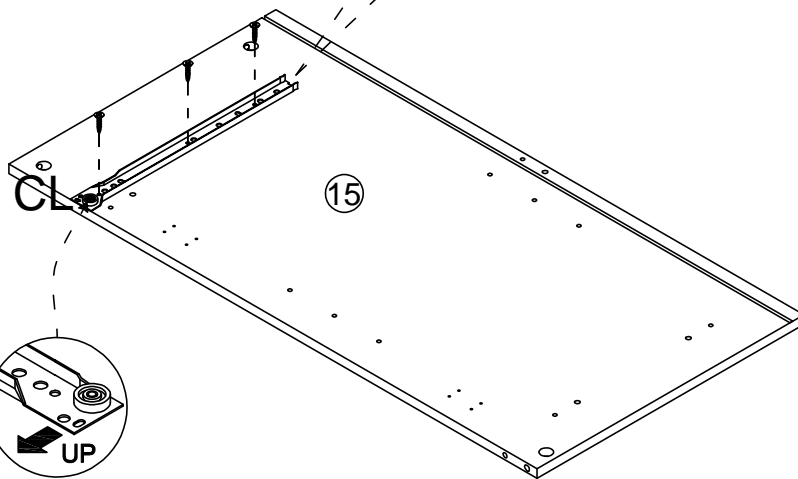
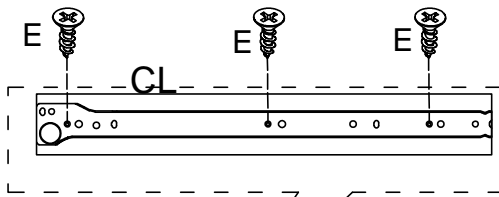
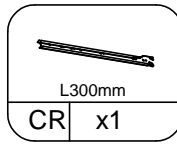
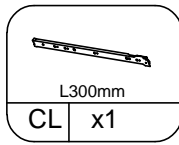
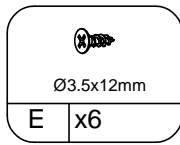
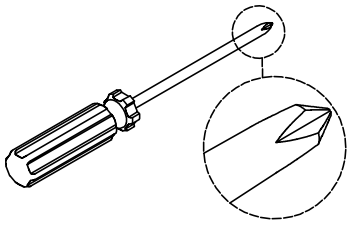

# STEP 6

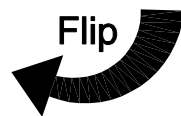
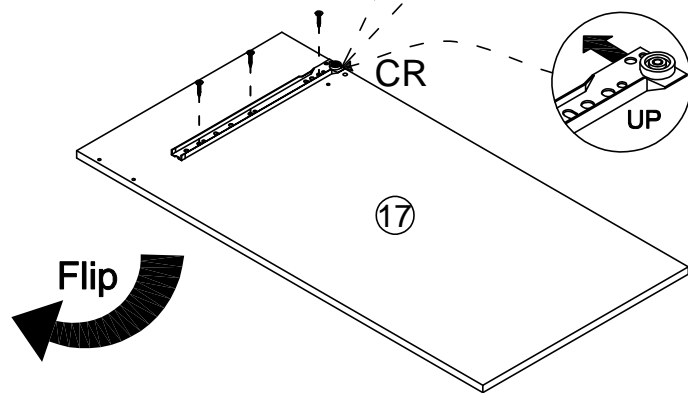
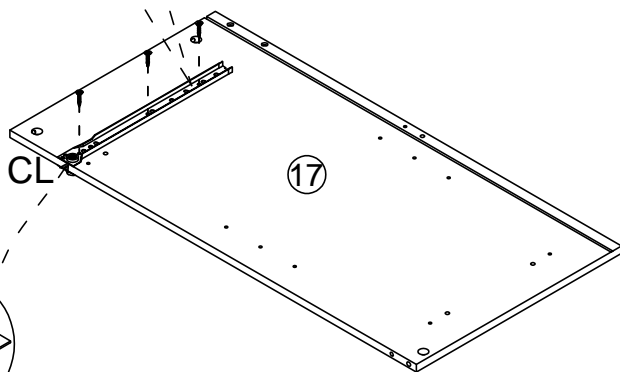
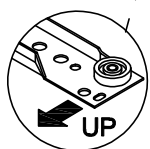
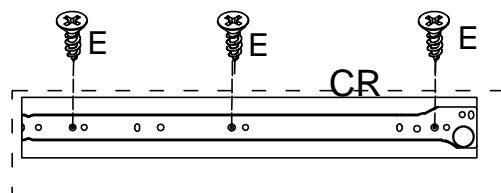
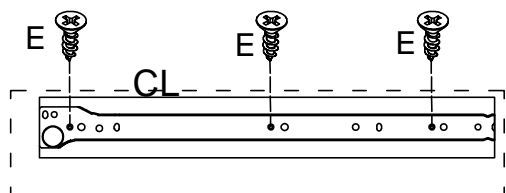
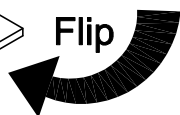
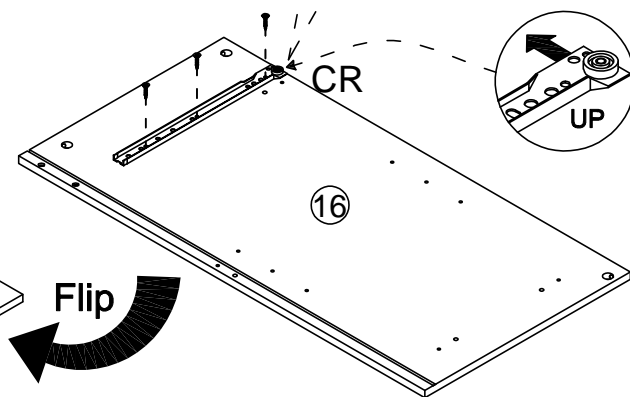
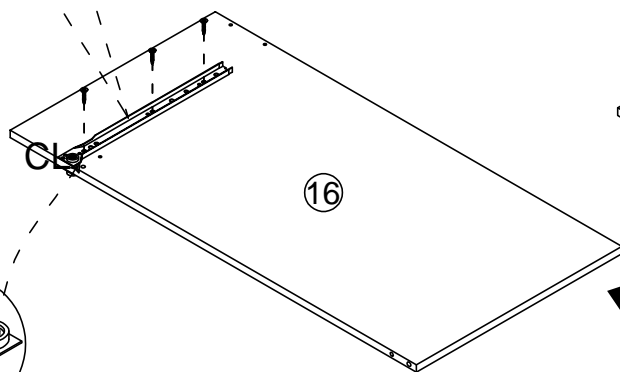
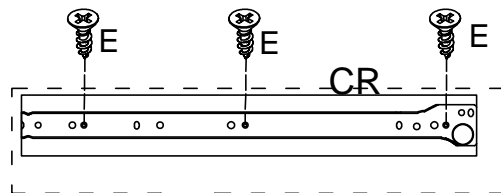
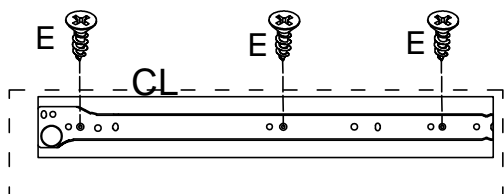
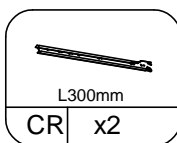
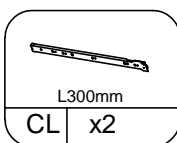
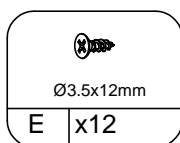
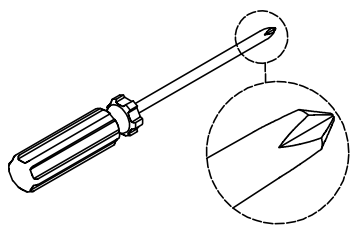

# STEP 7

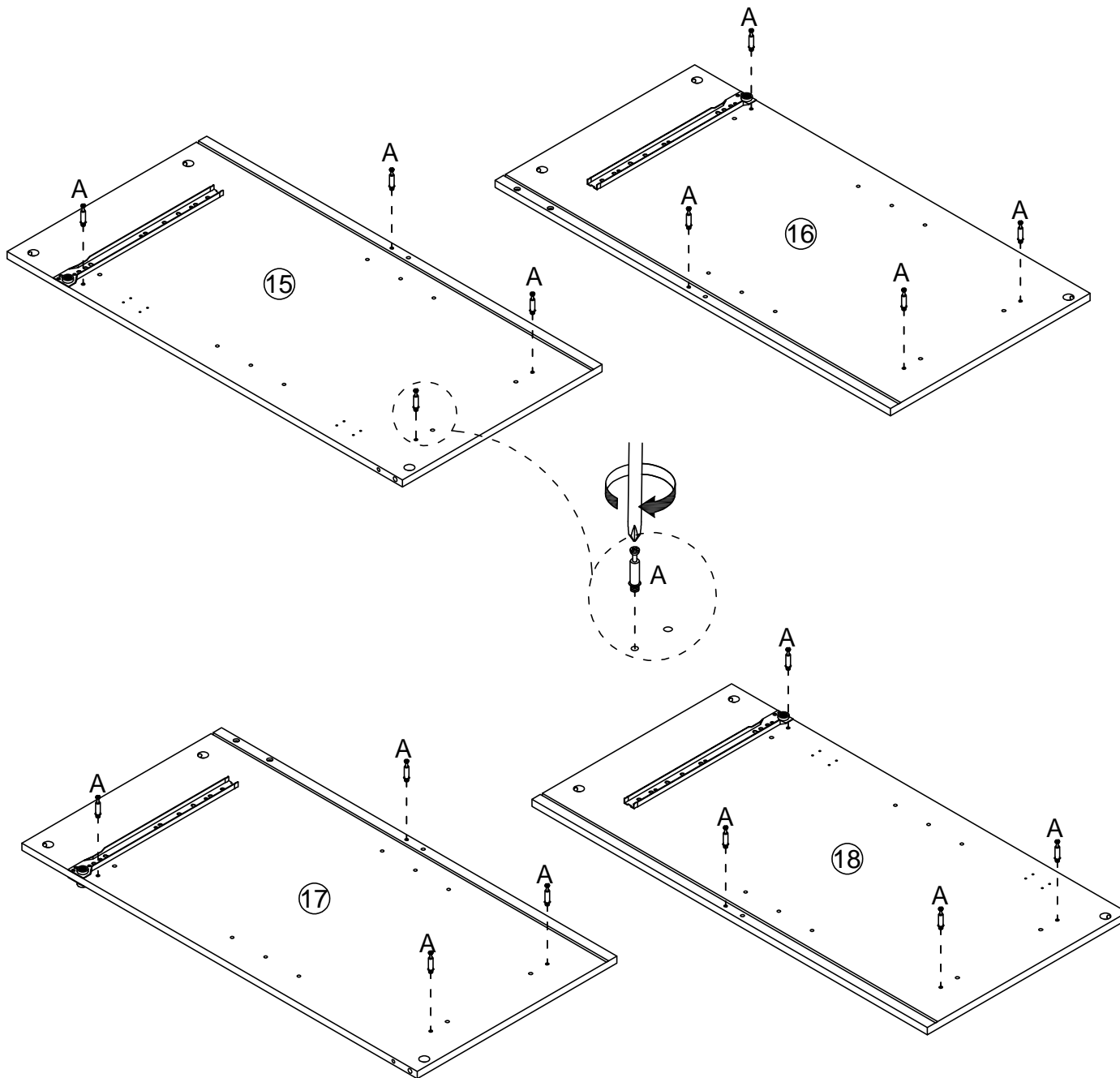
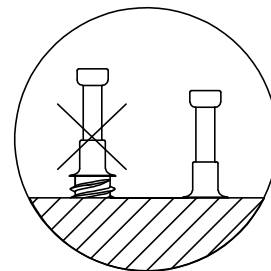
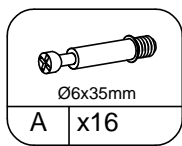
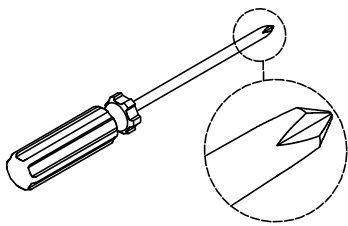

# STEP 8

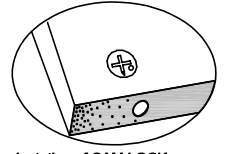
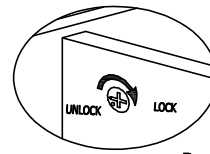
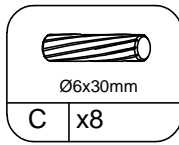
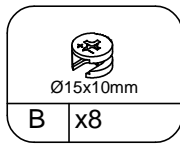
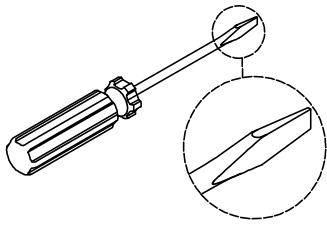

Proper orientation of CAM LOCK

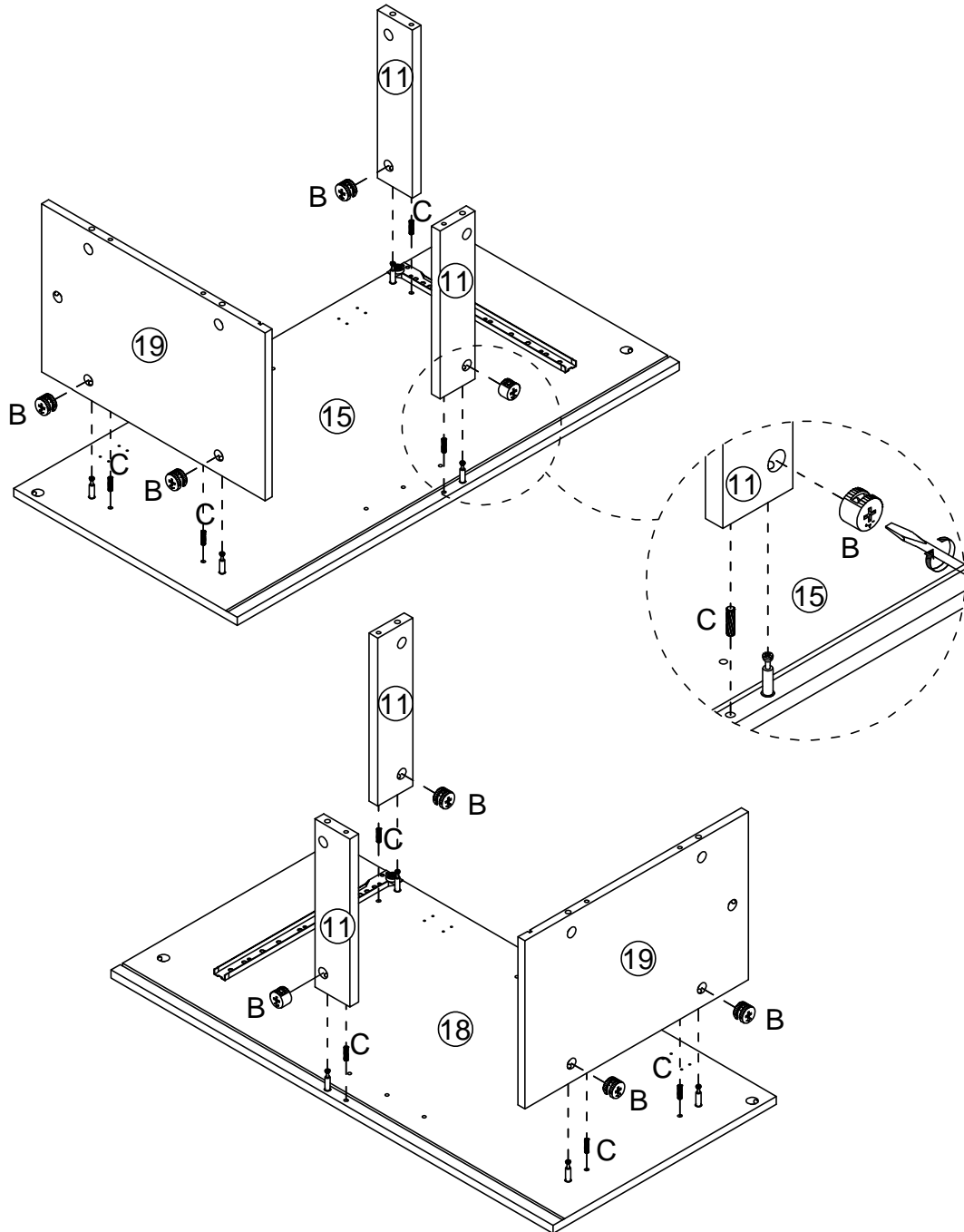

# STEP 9

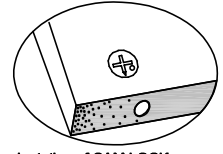
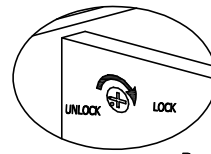
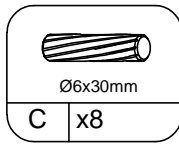
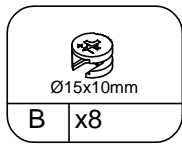
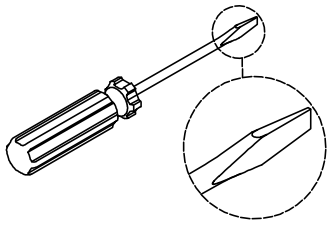

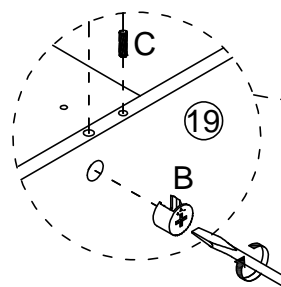
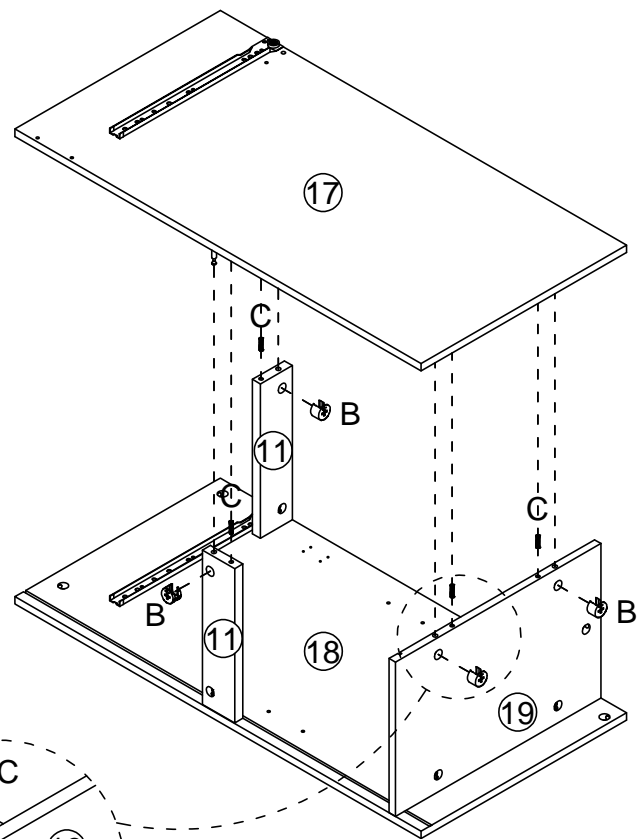
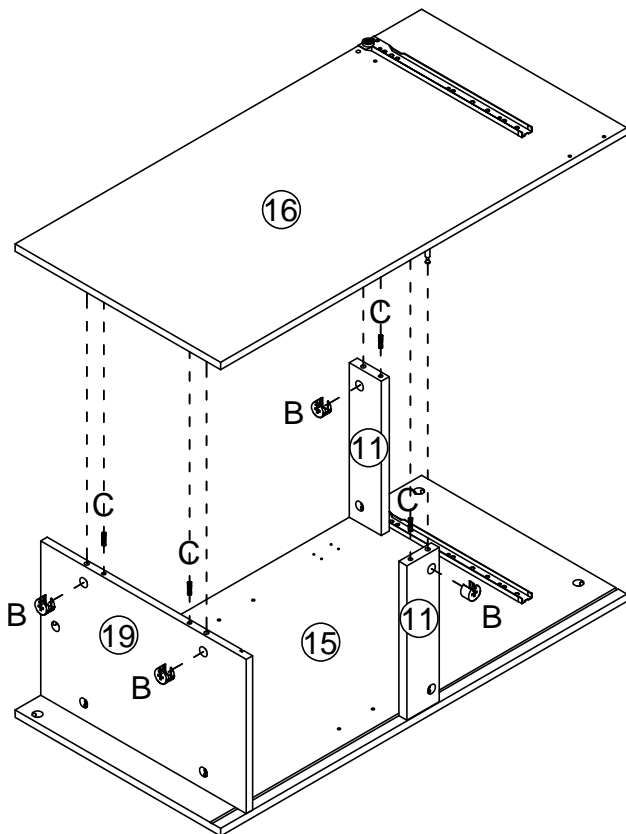

Proper orientation of CAM LOCK



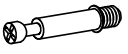

# STEP 10

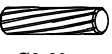
		
Ø6x35mm	Ø15x10mm	Ø6x30mm
A x8	B x6	C x8

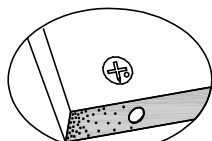
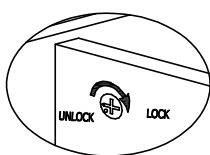
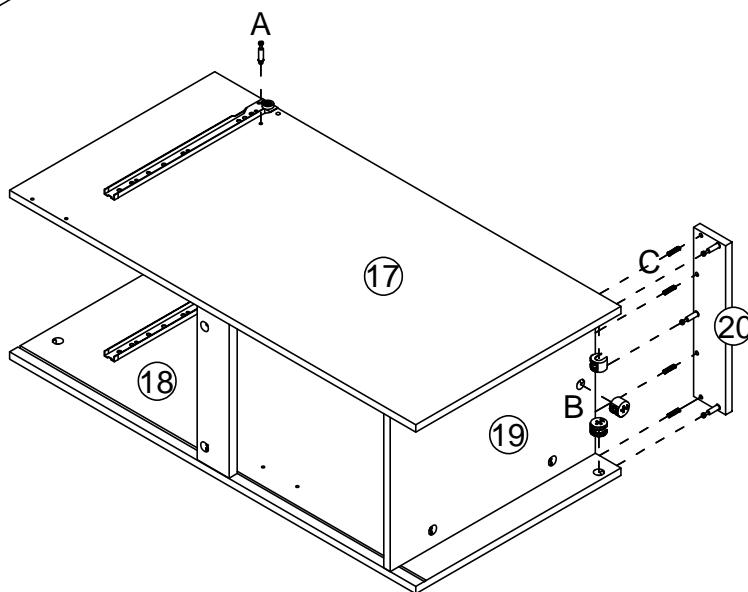
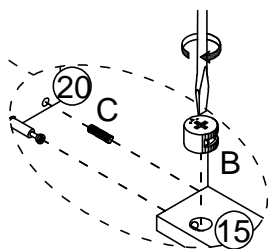
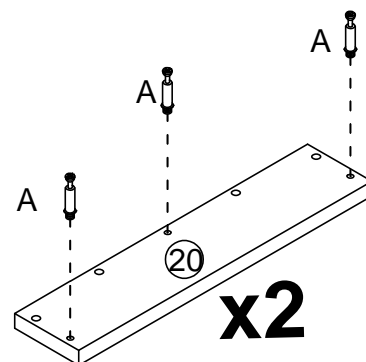
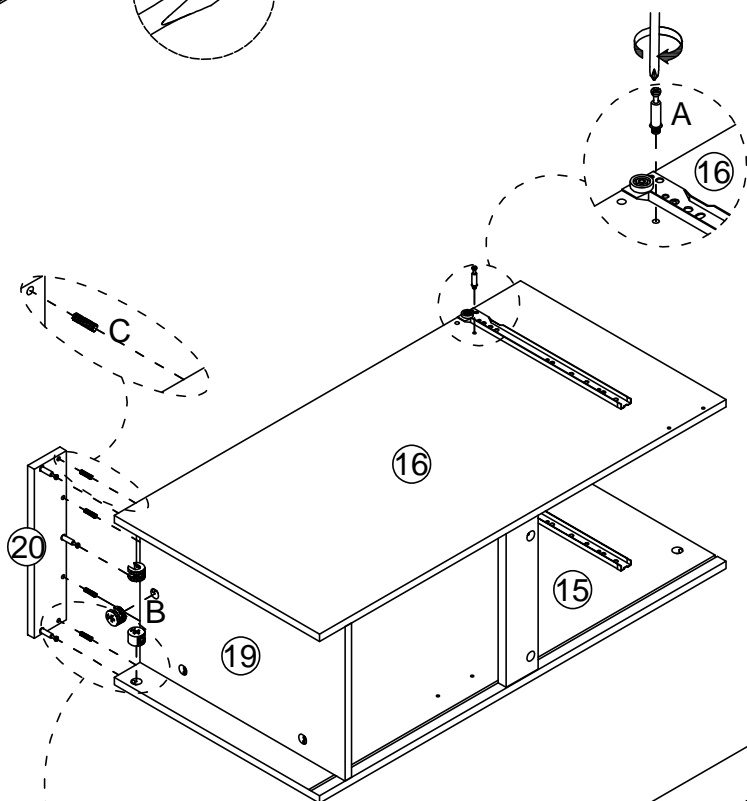
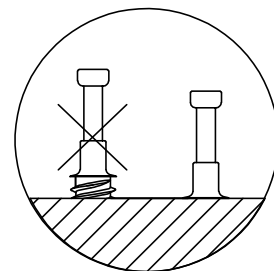
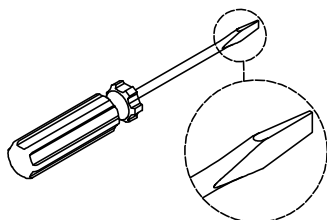
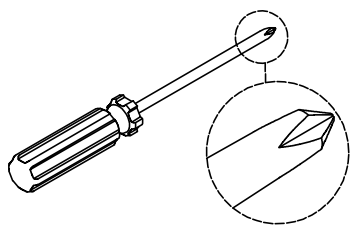

Proper orientation of CAM LOCK

# STEP 11

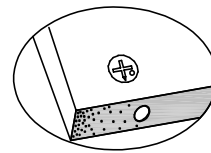
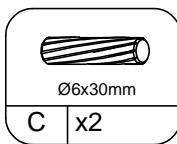
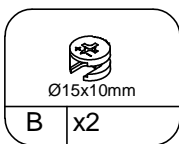
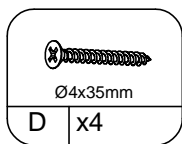
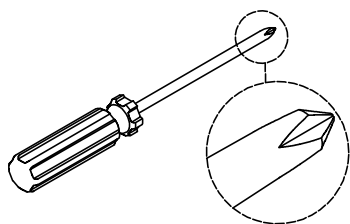

Proper orientation of CAM LOCK

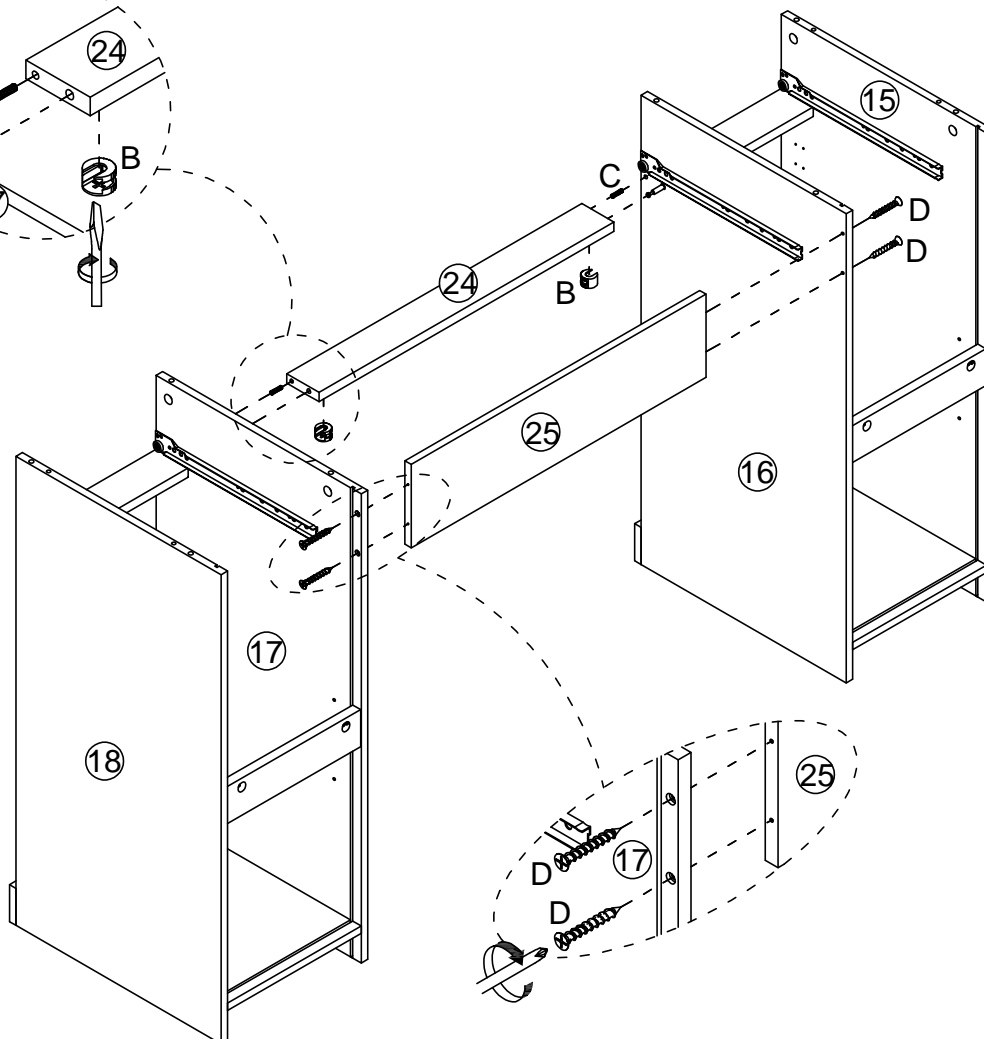
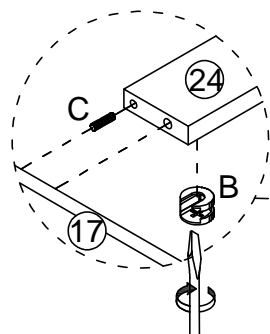
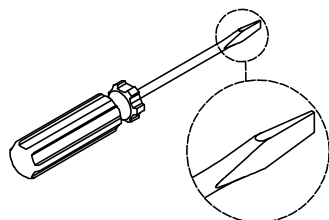

# STEP 12

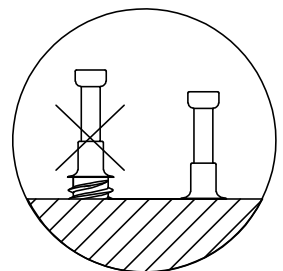
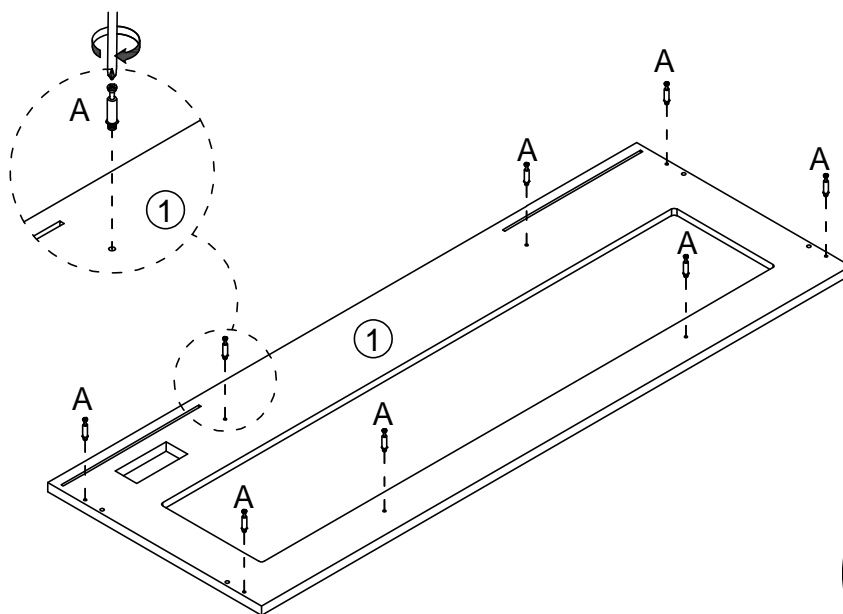
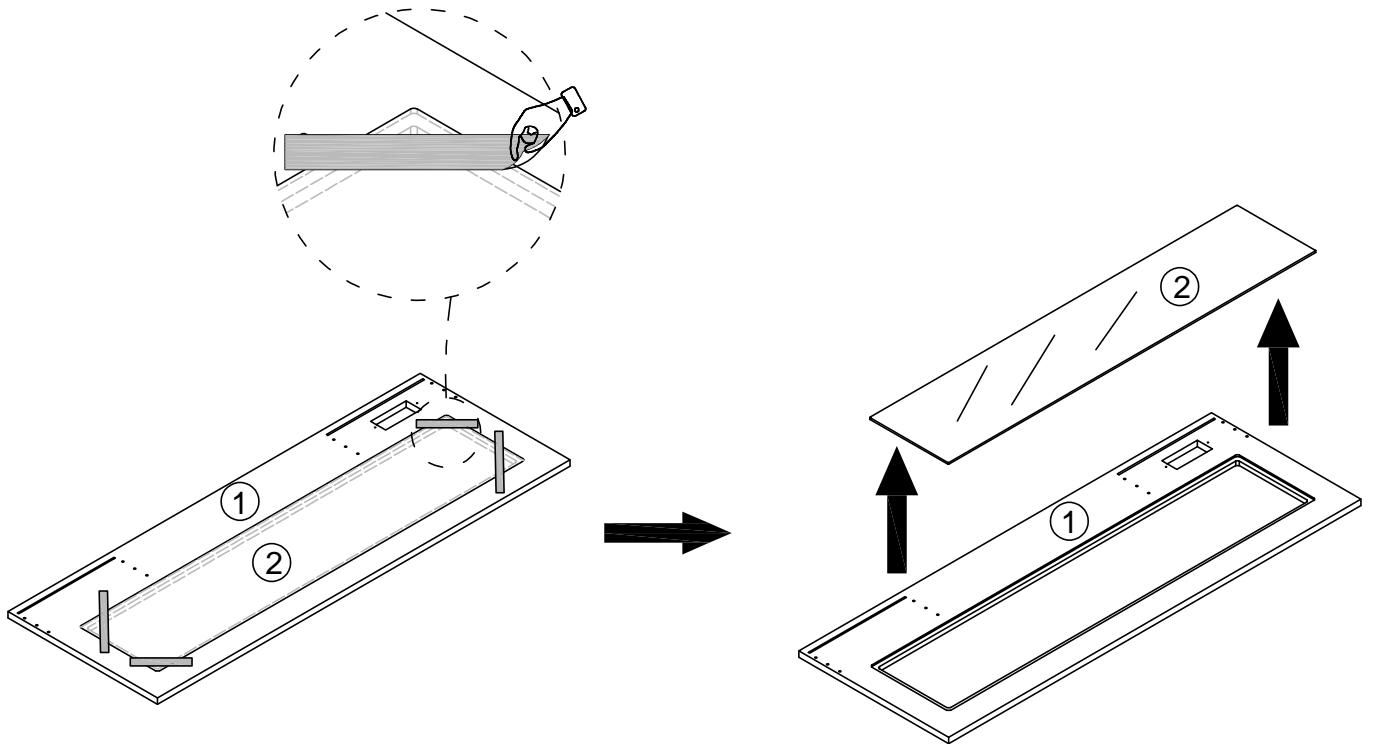
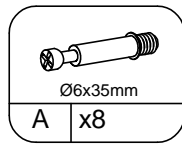
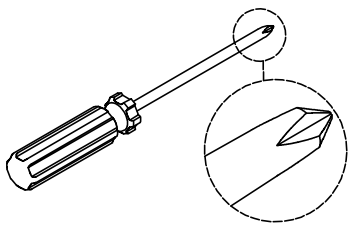

# STEP 13

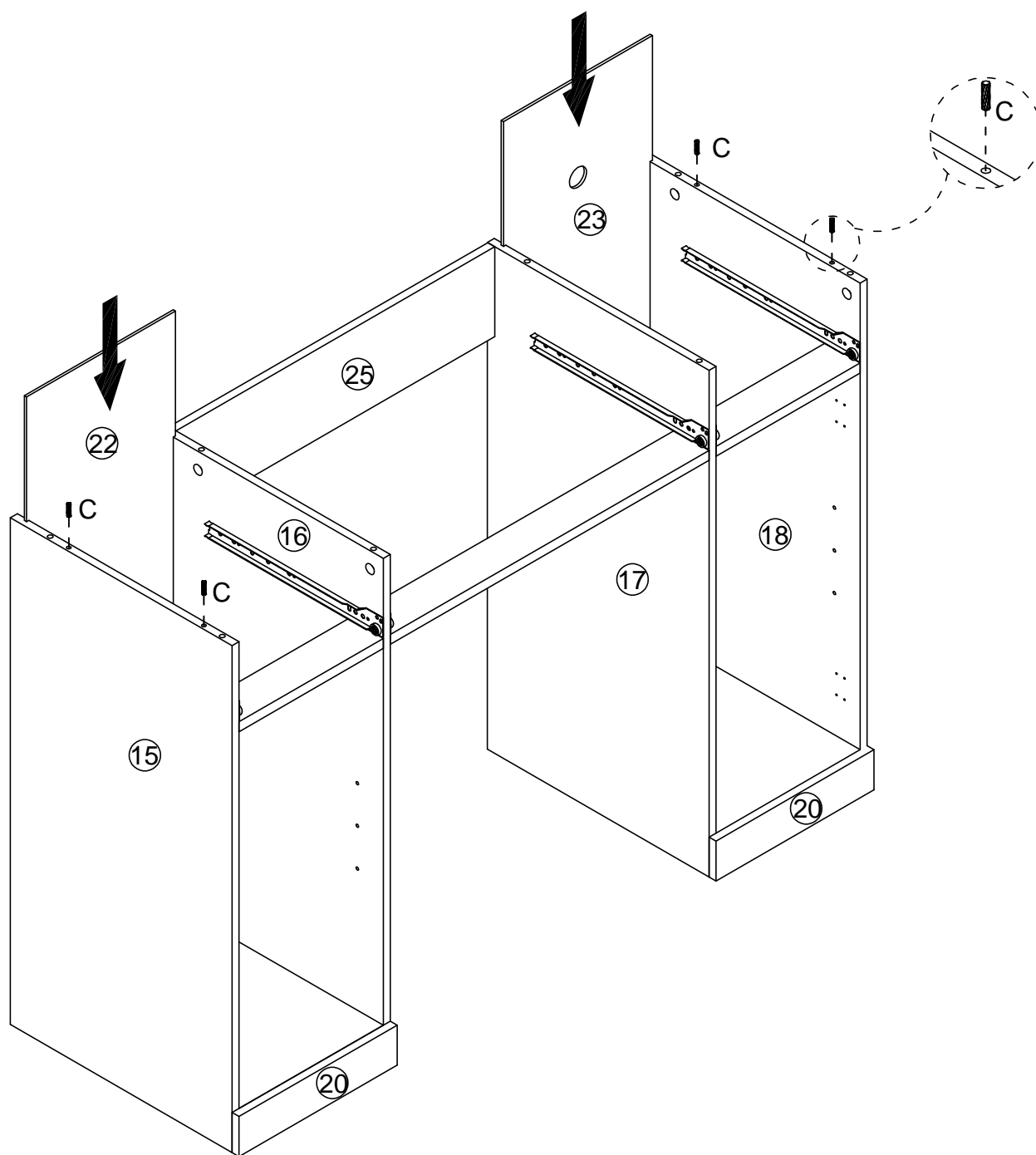
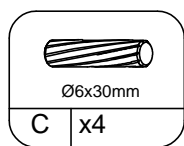

# STEP 14

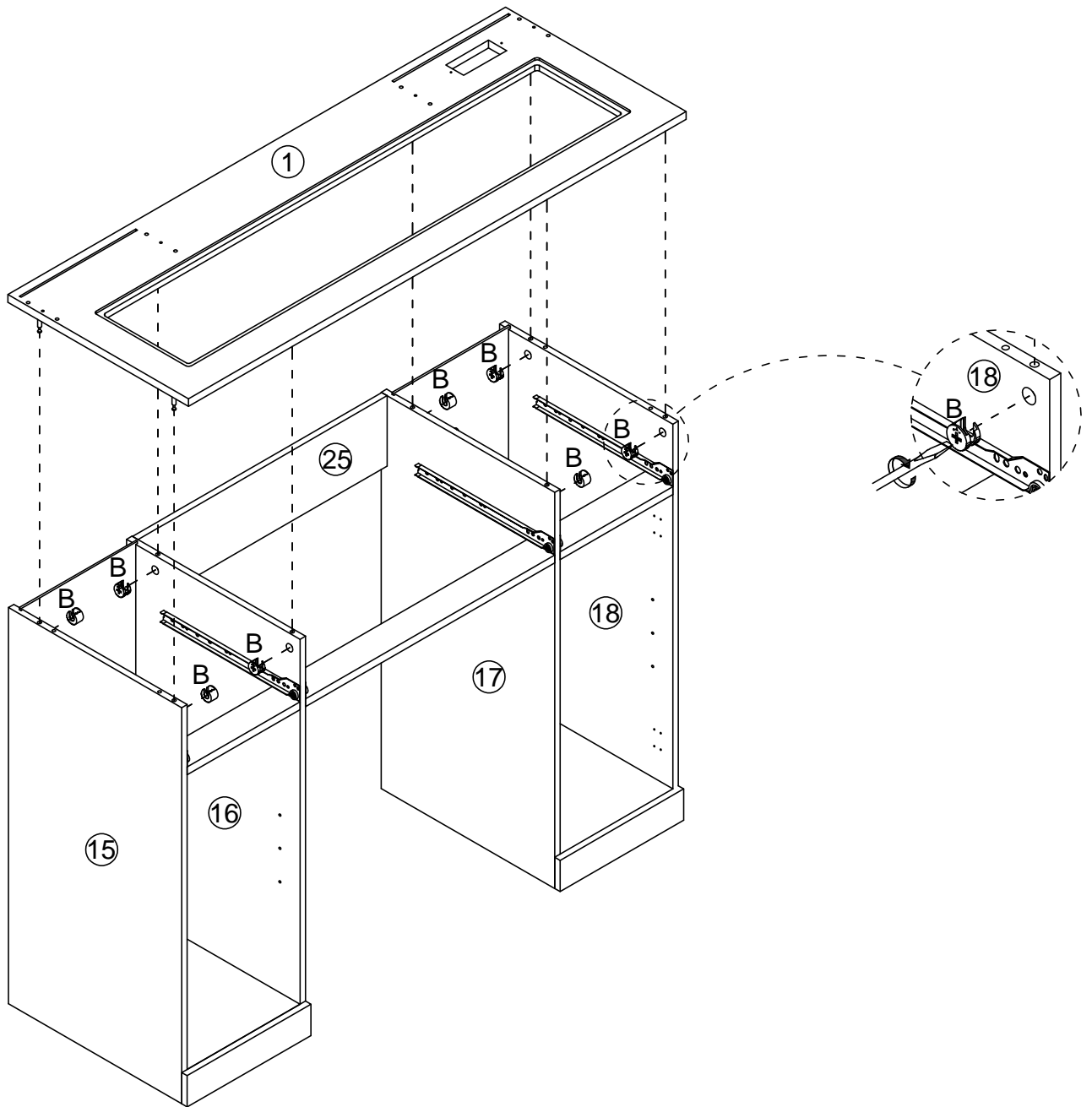
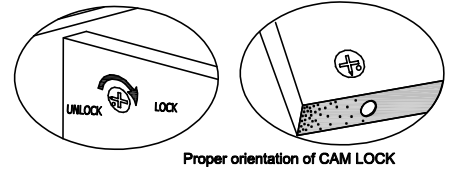
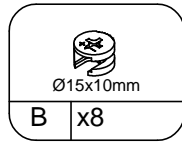
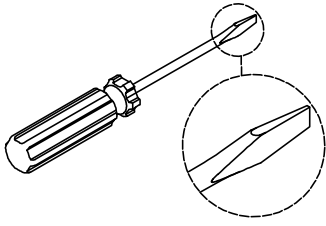

# STEP 15

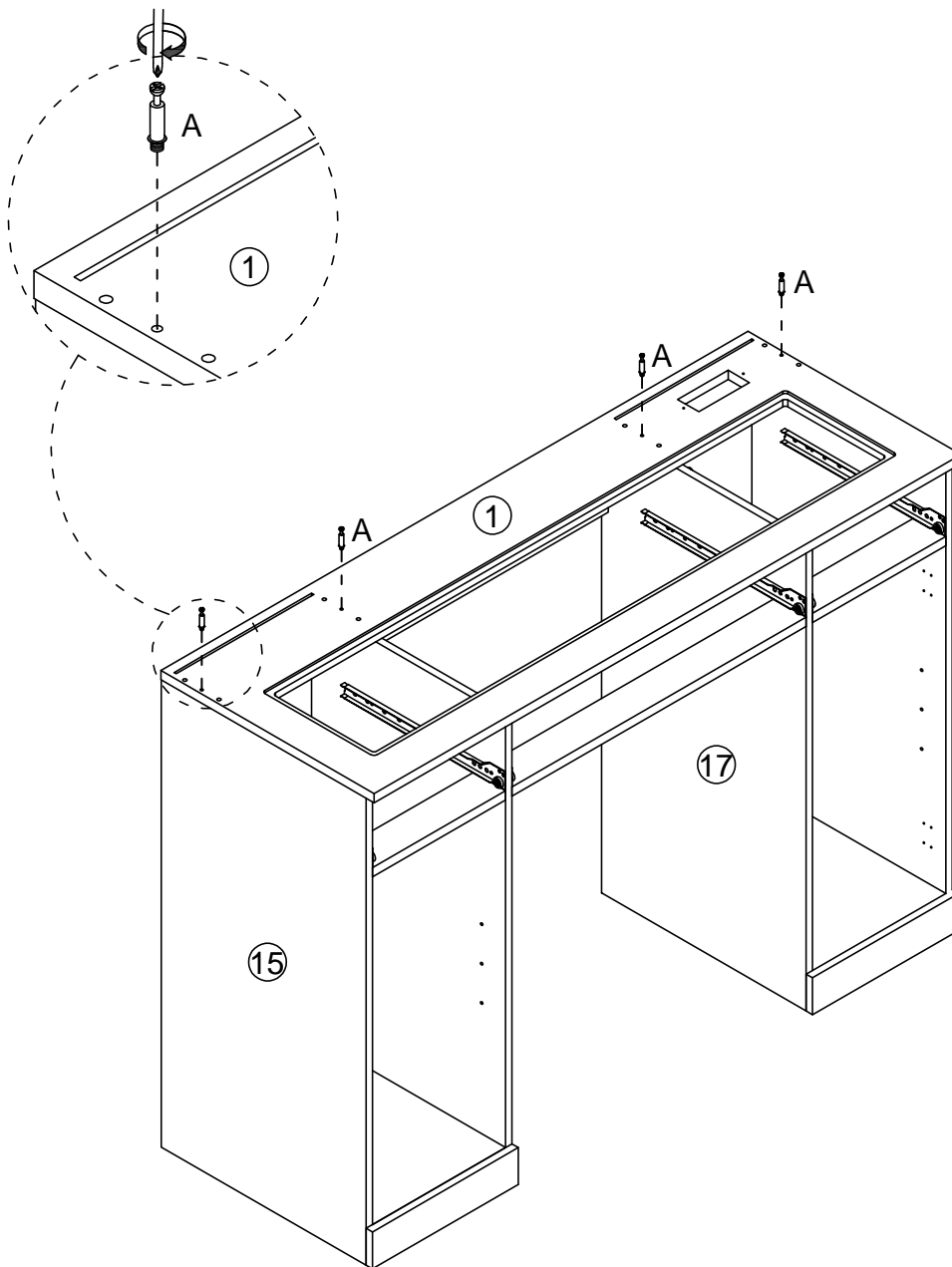
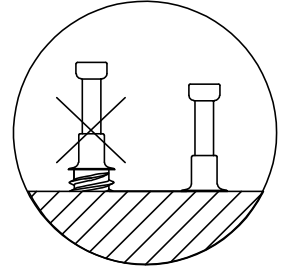
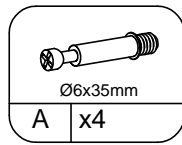
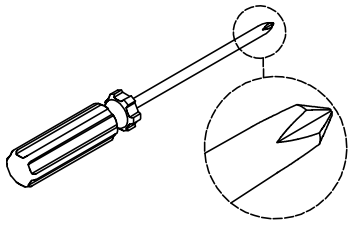

# STEP 16

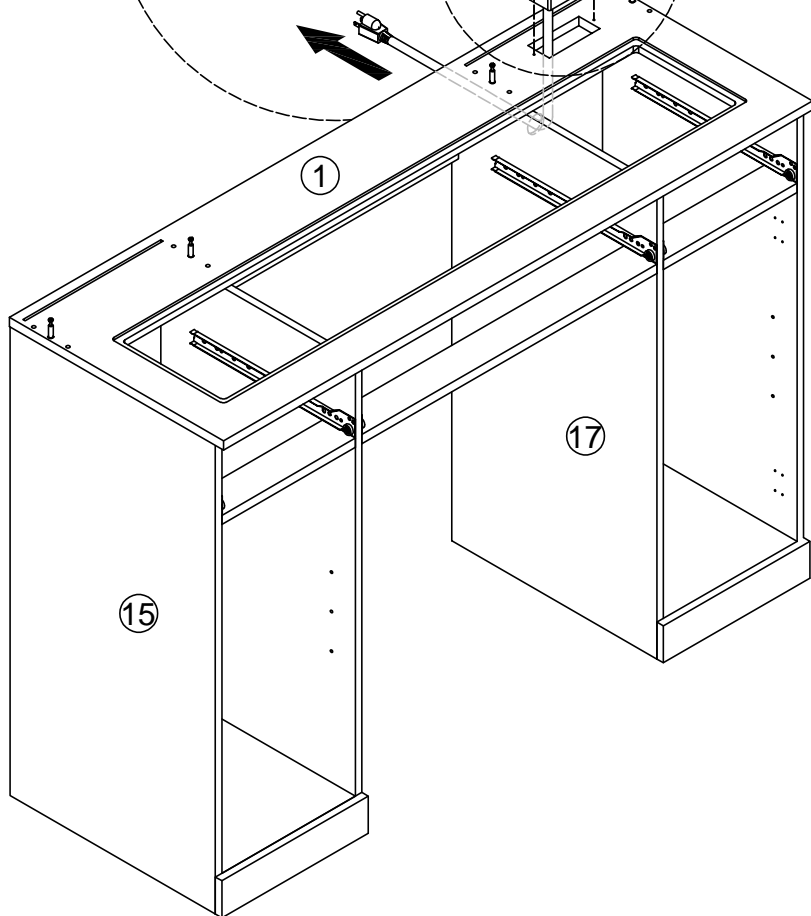
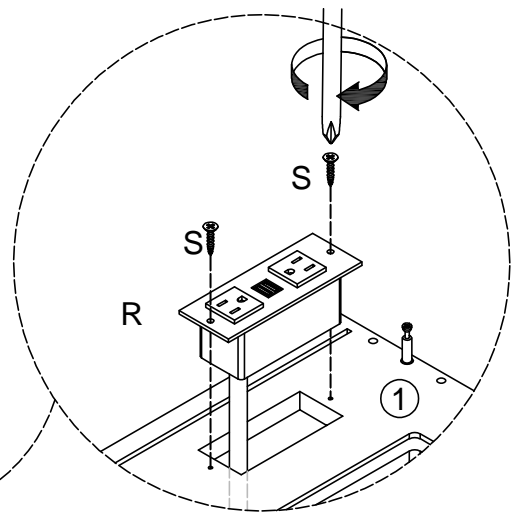
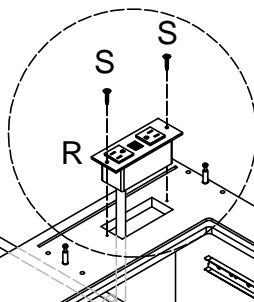
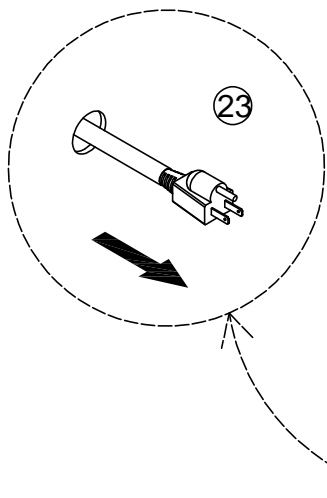
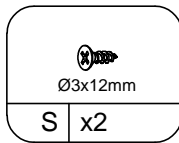
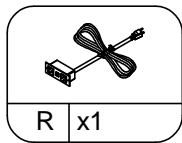
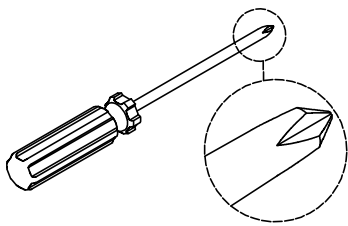

# STEP 17

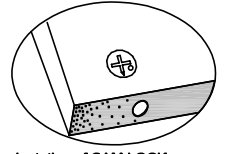
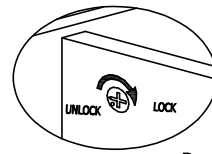
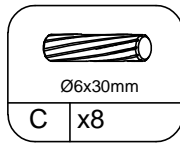
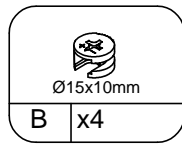
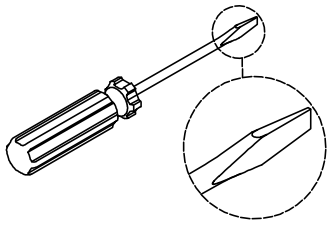

Proper orientation of CAM LOCK

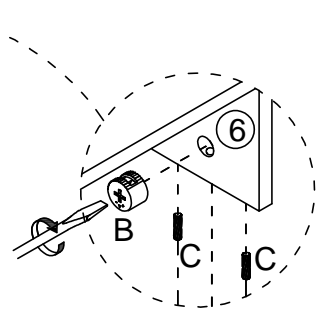
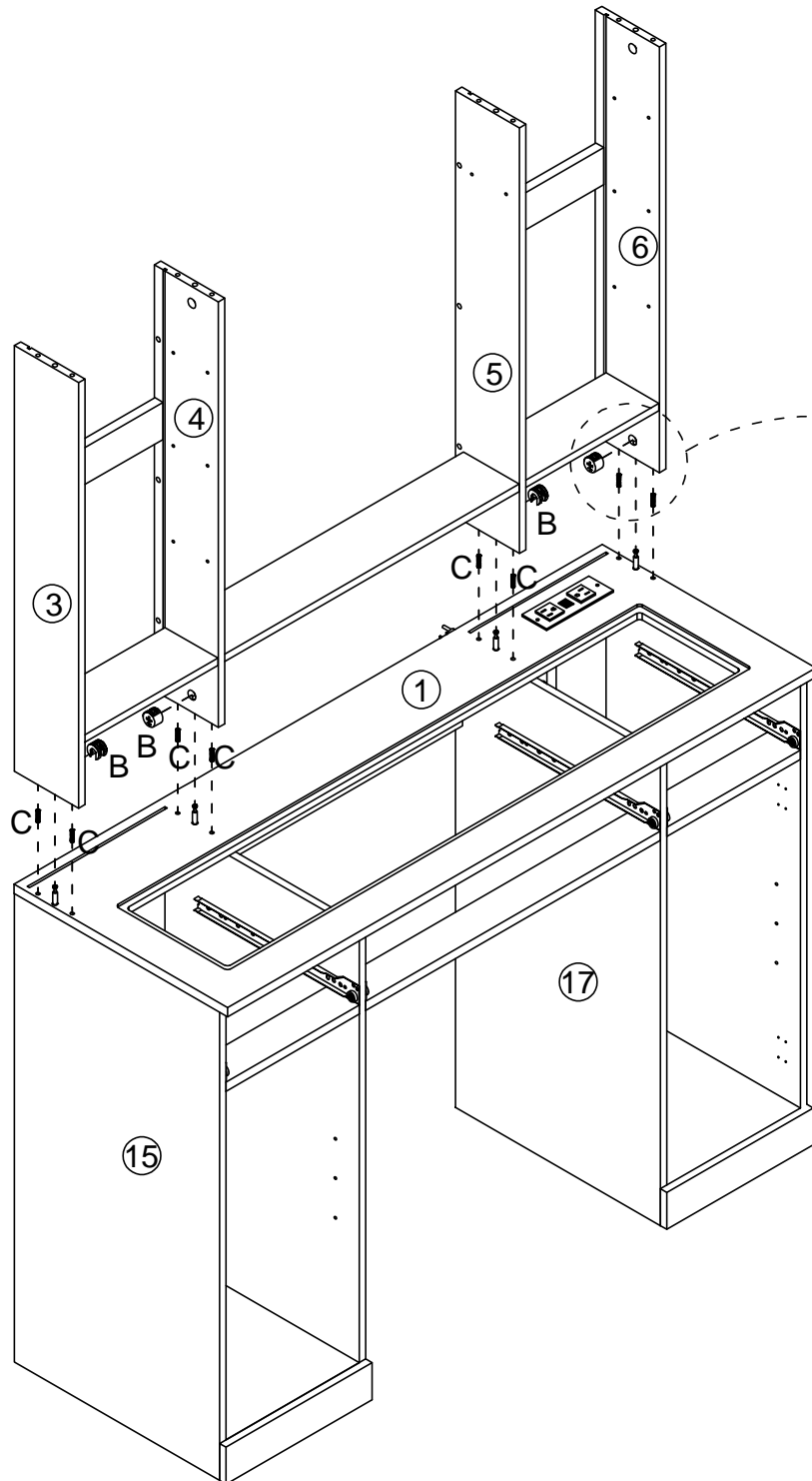
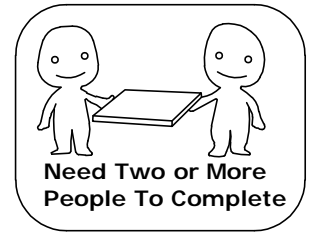



# STEP 18

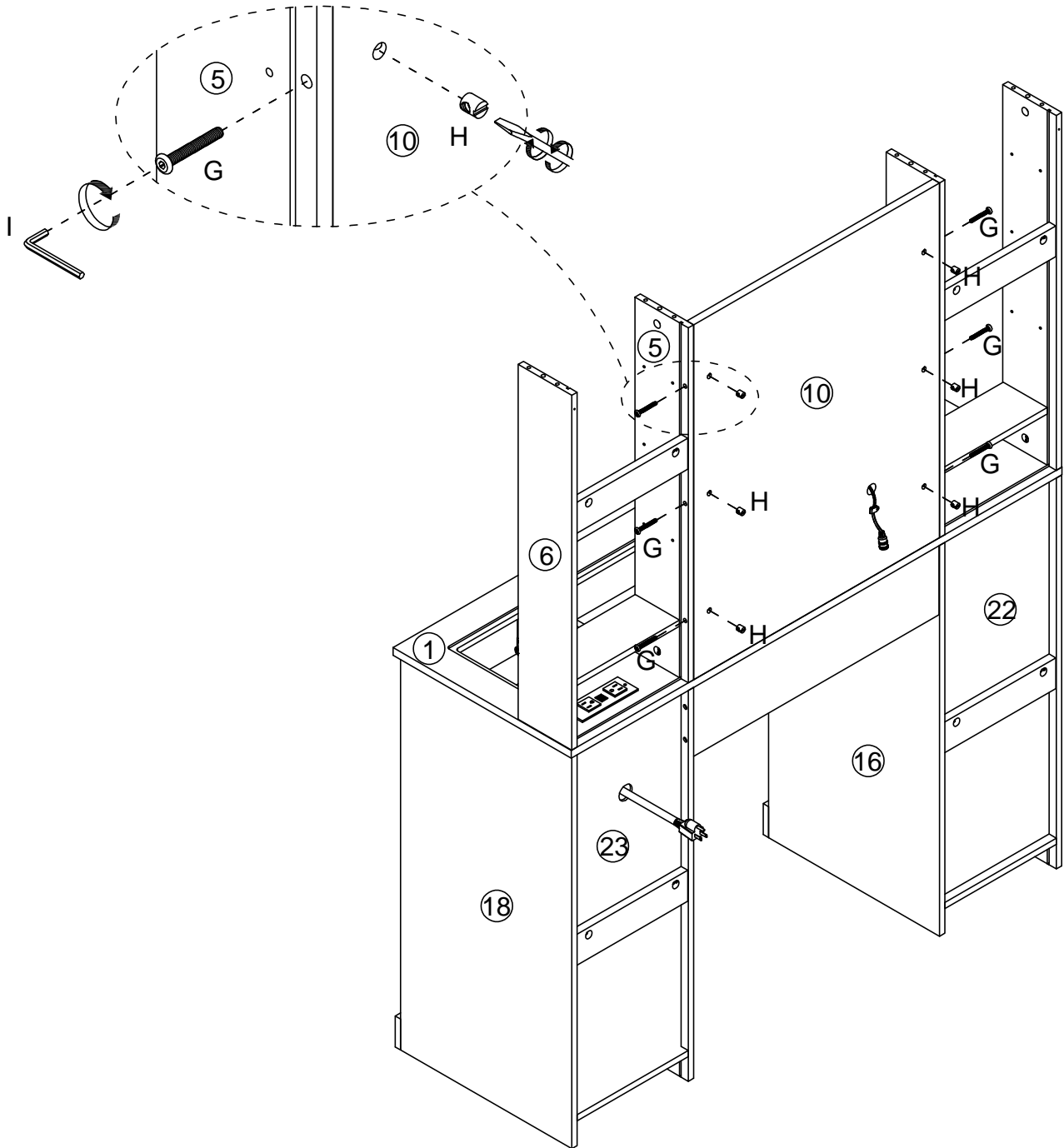
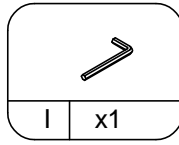
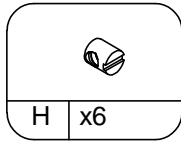
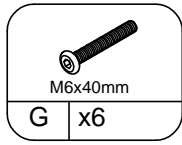
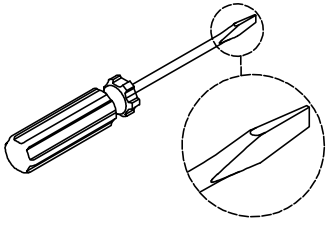

# STEP 19

---

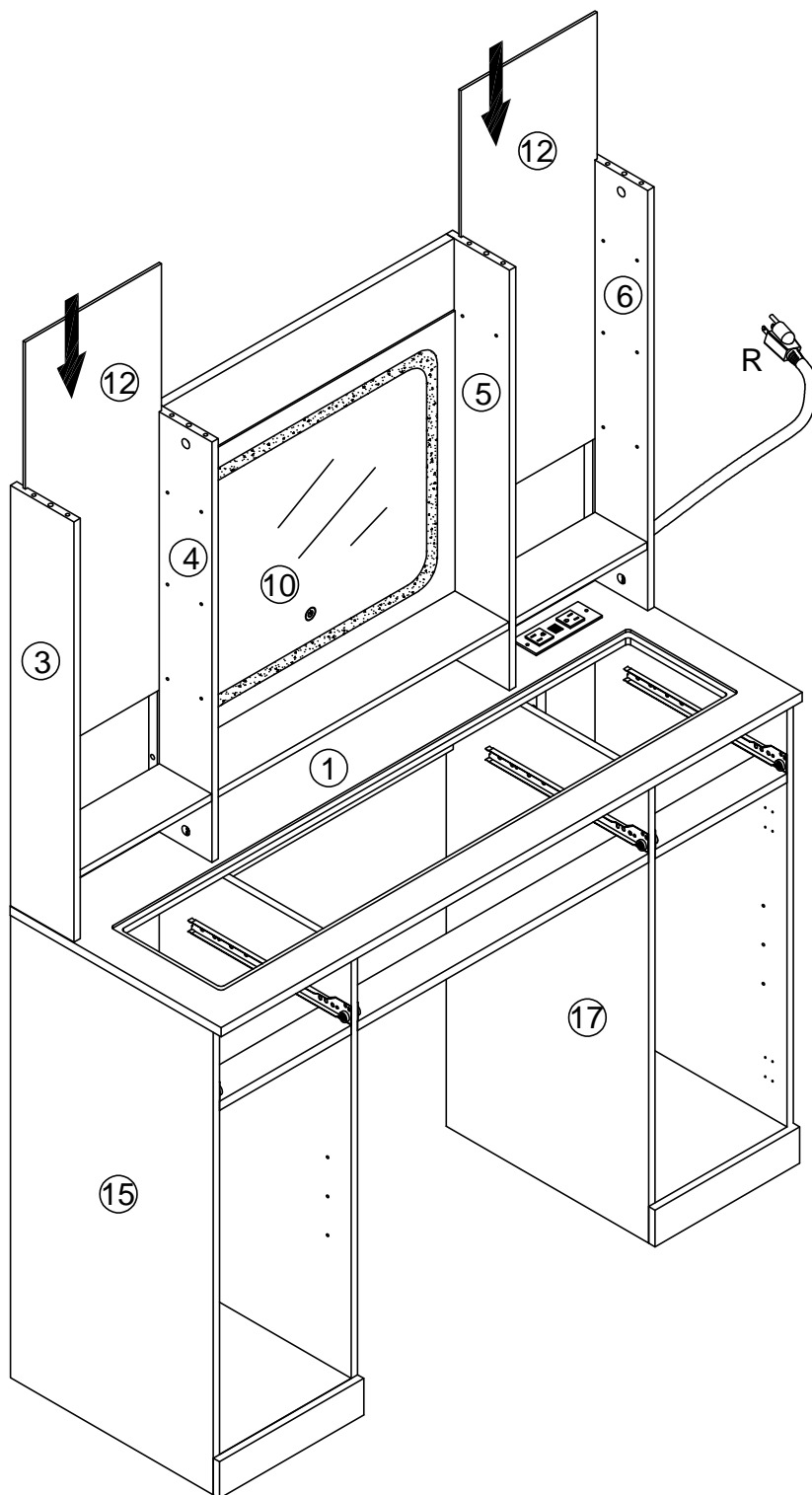

# STEP 20

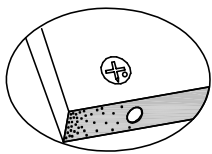
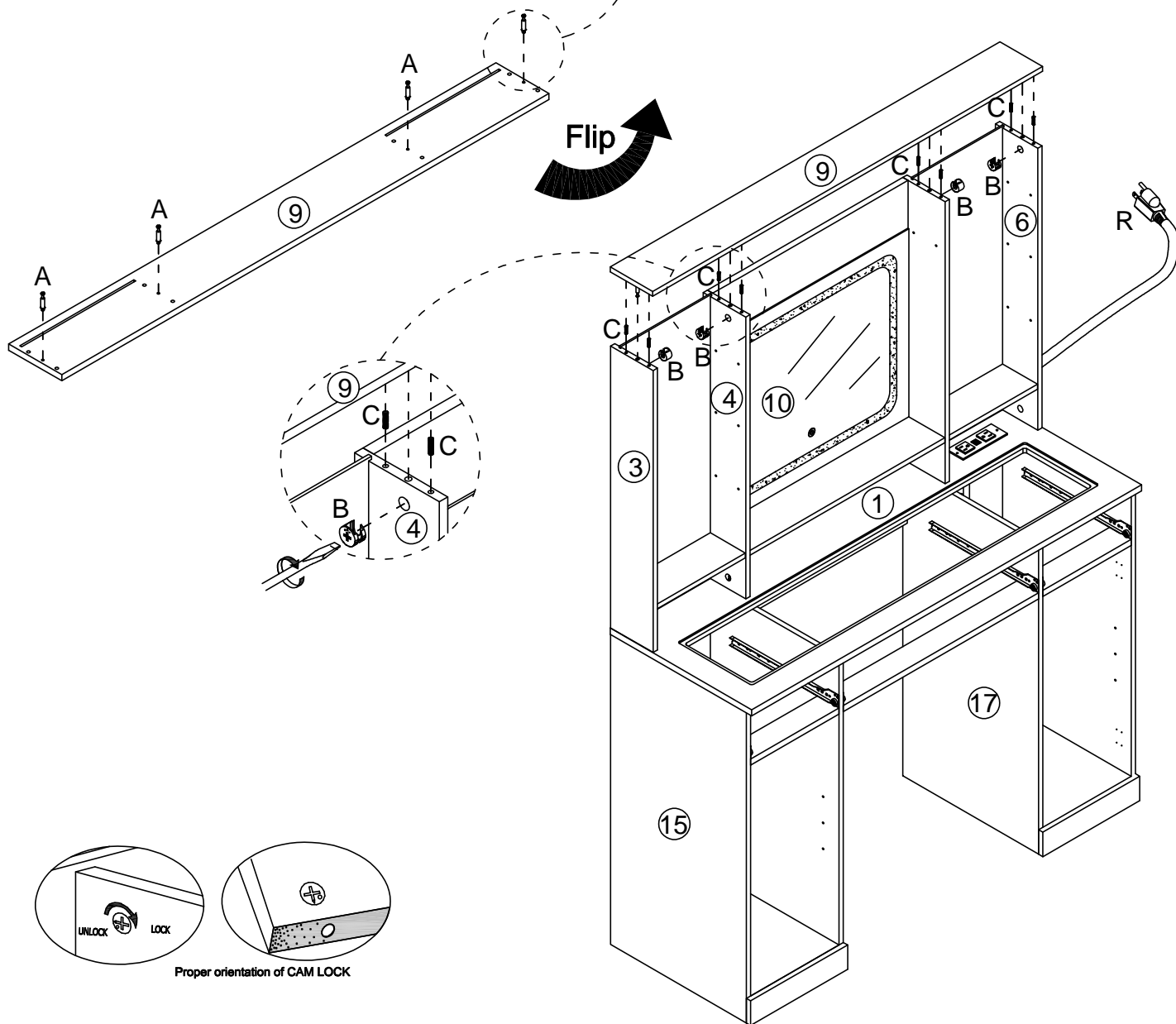
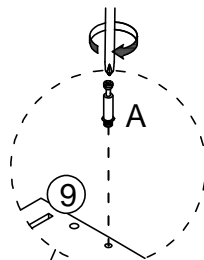
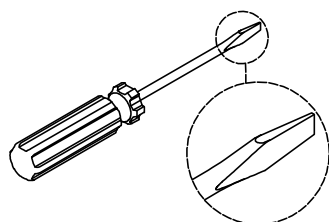
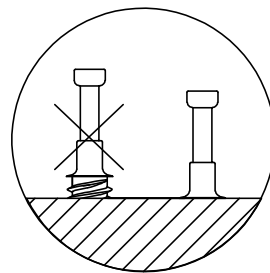
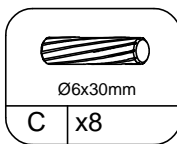
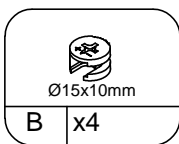
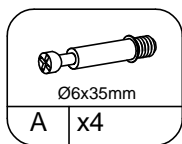
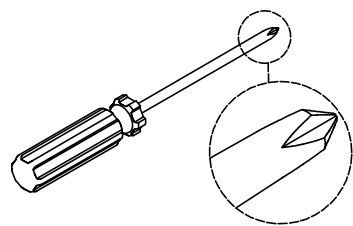

Proper orientation of CAM LOCK

# STEP 21

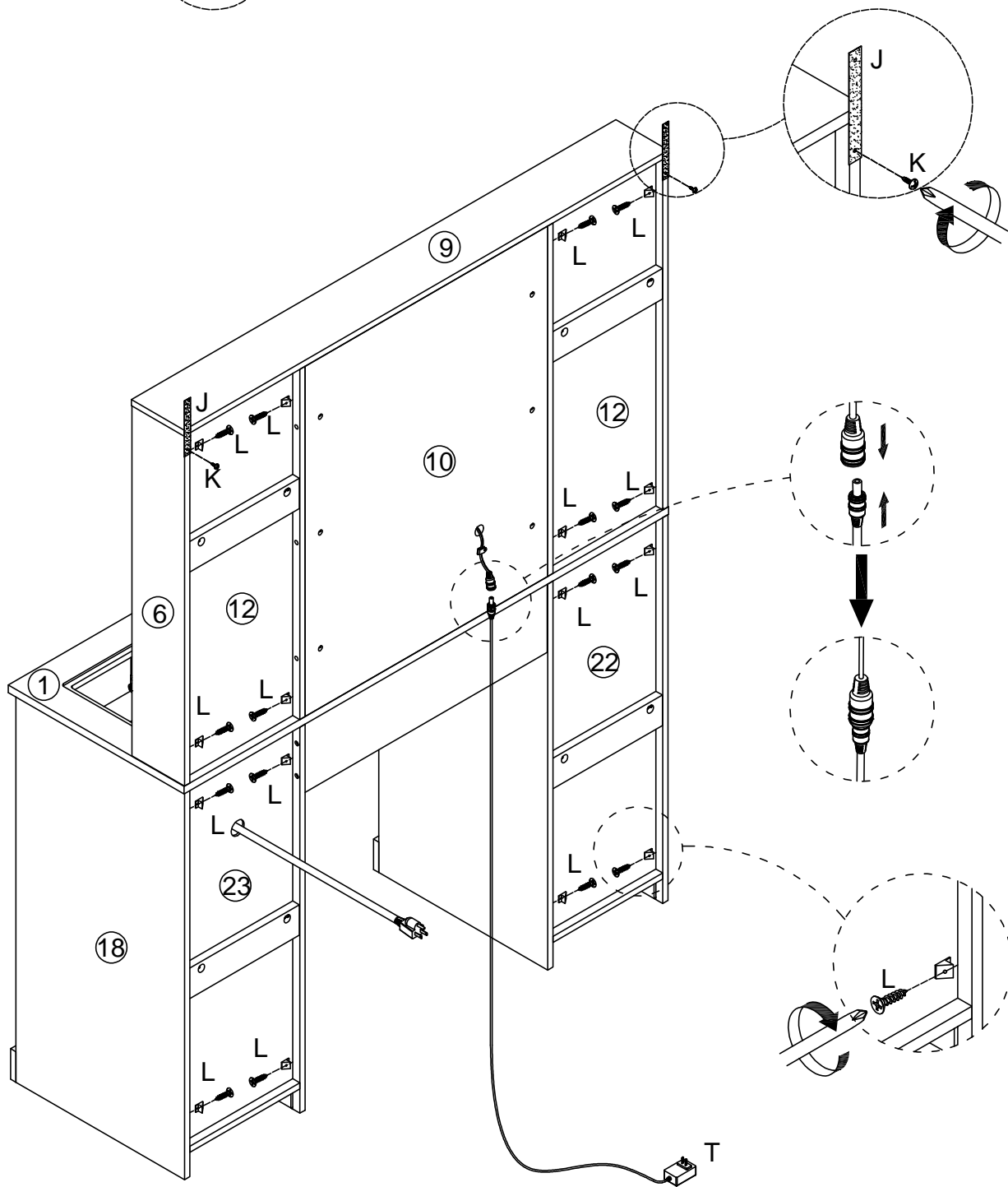
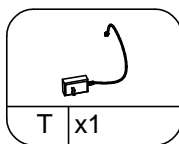
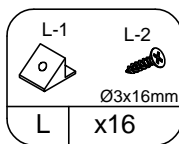
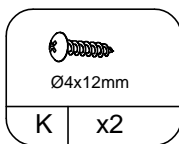
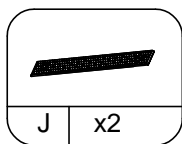
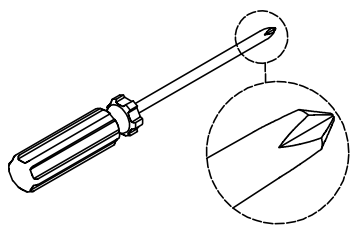

# STEP 22

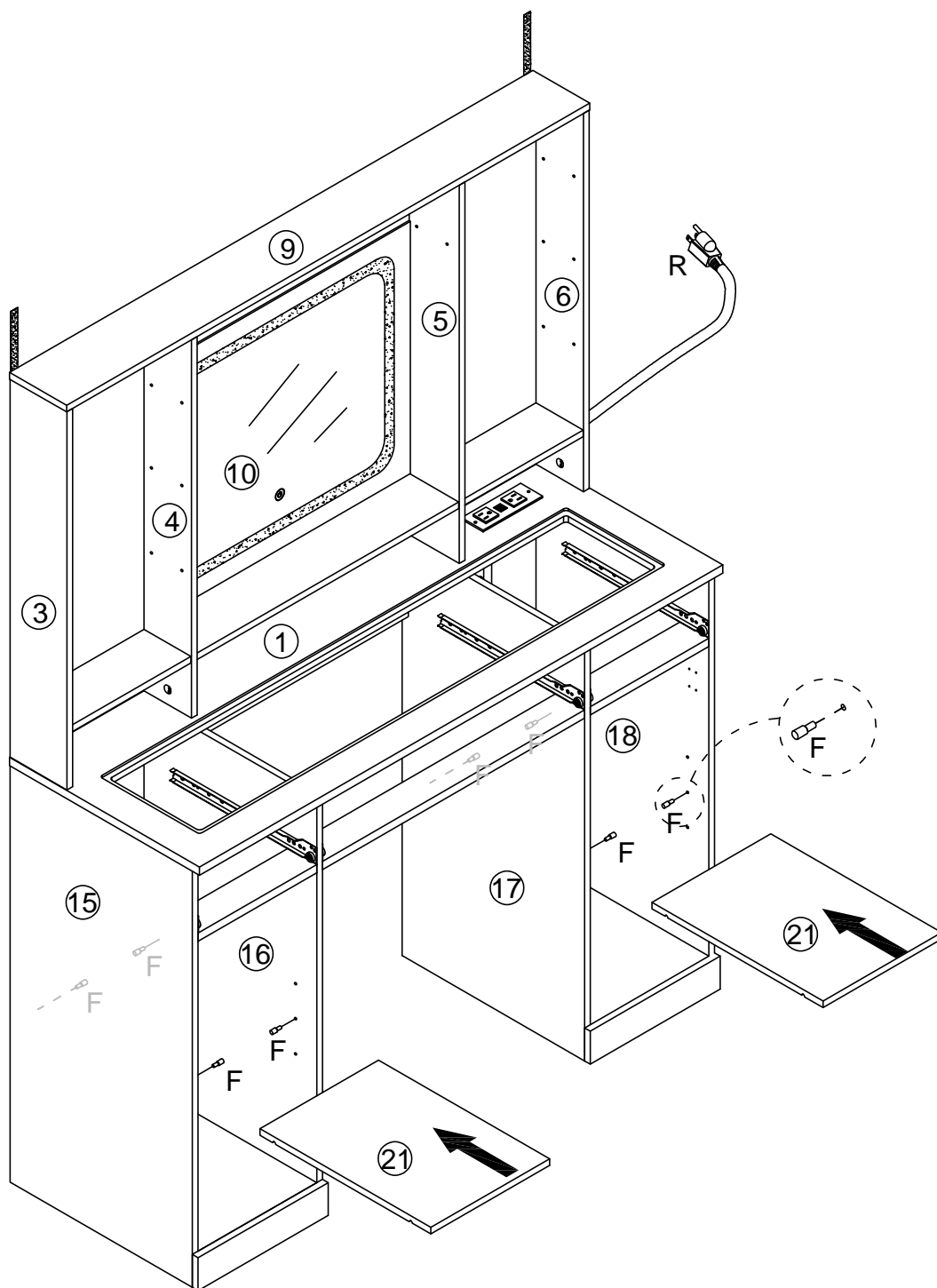
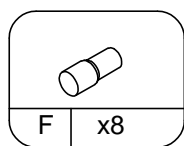

# STEP 23

---

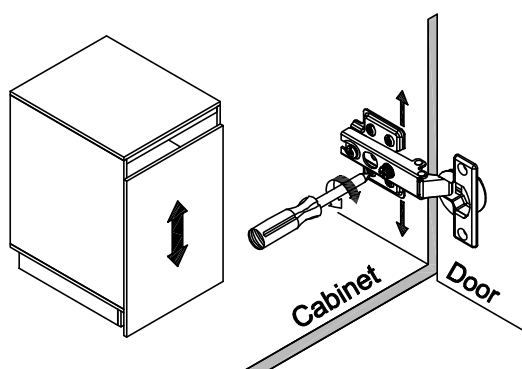
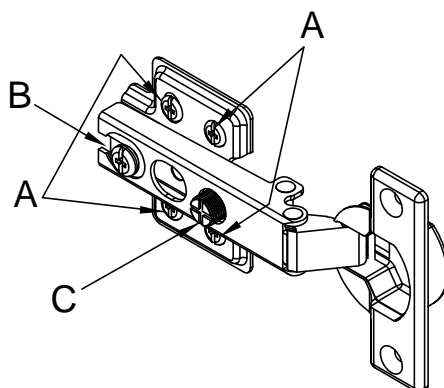

### To adjust the vertical height.

Loosen the four screws "A" on both hinges. Two of them are usually in slotted holes which allows you to adjust up or down by a few mm. Then tighten back up.

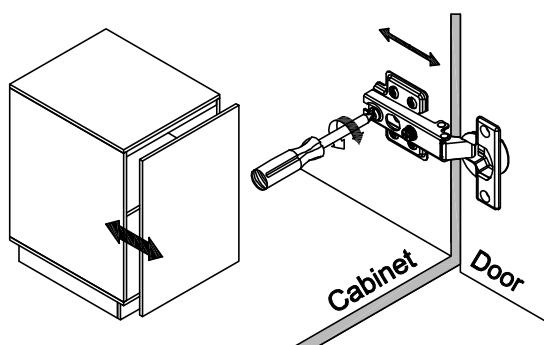

### To adjust depth.

Loosen screw "B" and adjust door, if the door can not be adjusted, please loosen screw "C", then try again. Tighten screw "B" and "C".

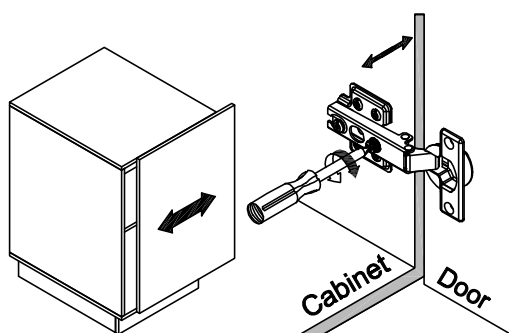

### To adjust side ways.

Turning the screw "C" on BOTH hinges on each door.

# STEP 24

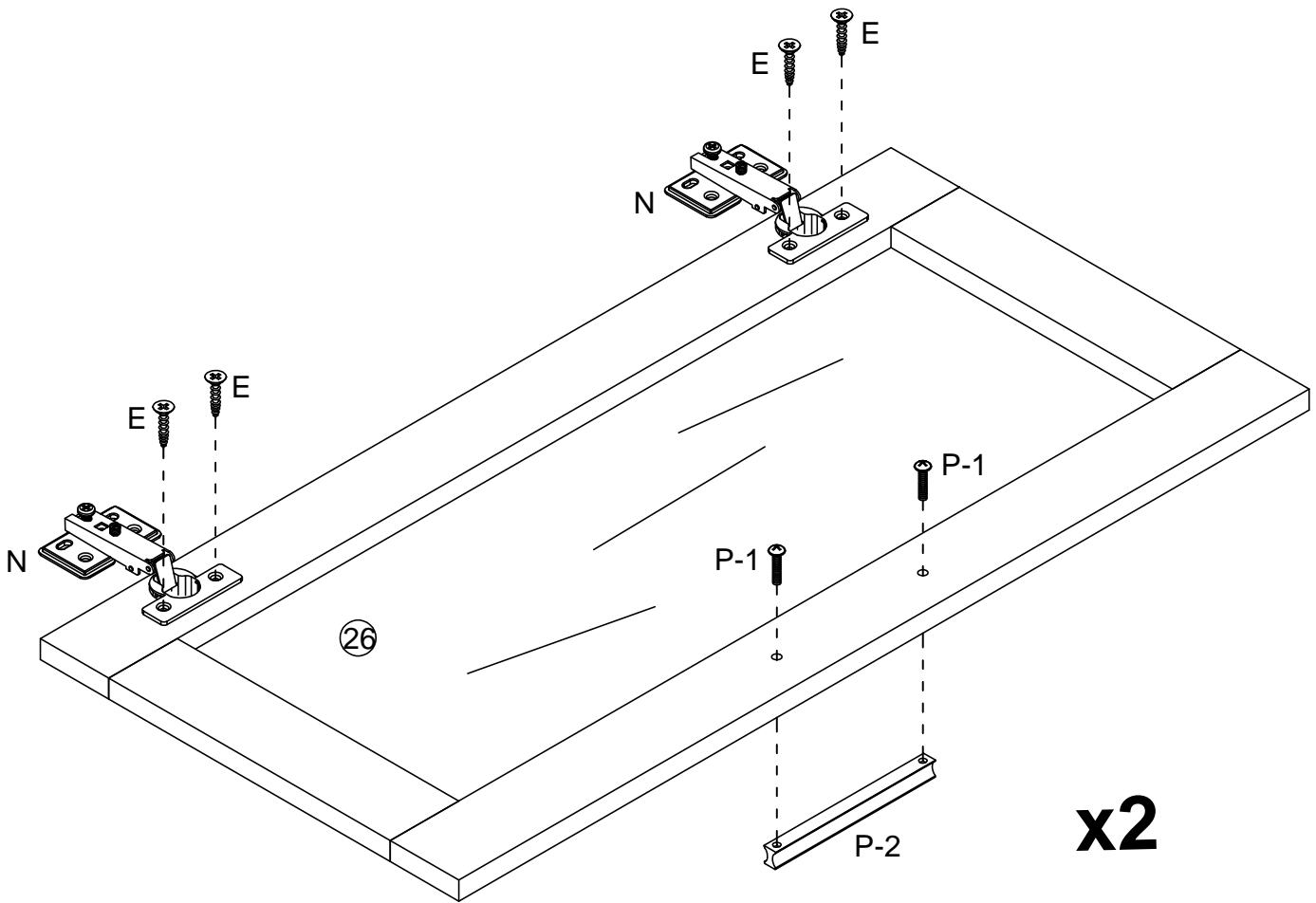
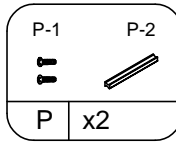
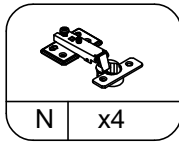
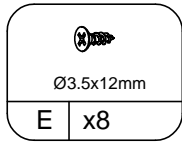
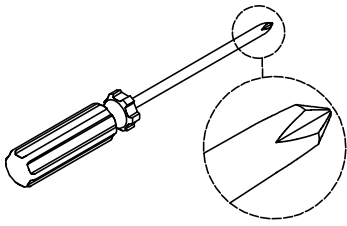

# STEP 25

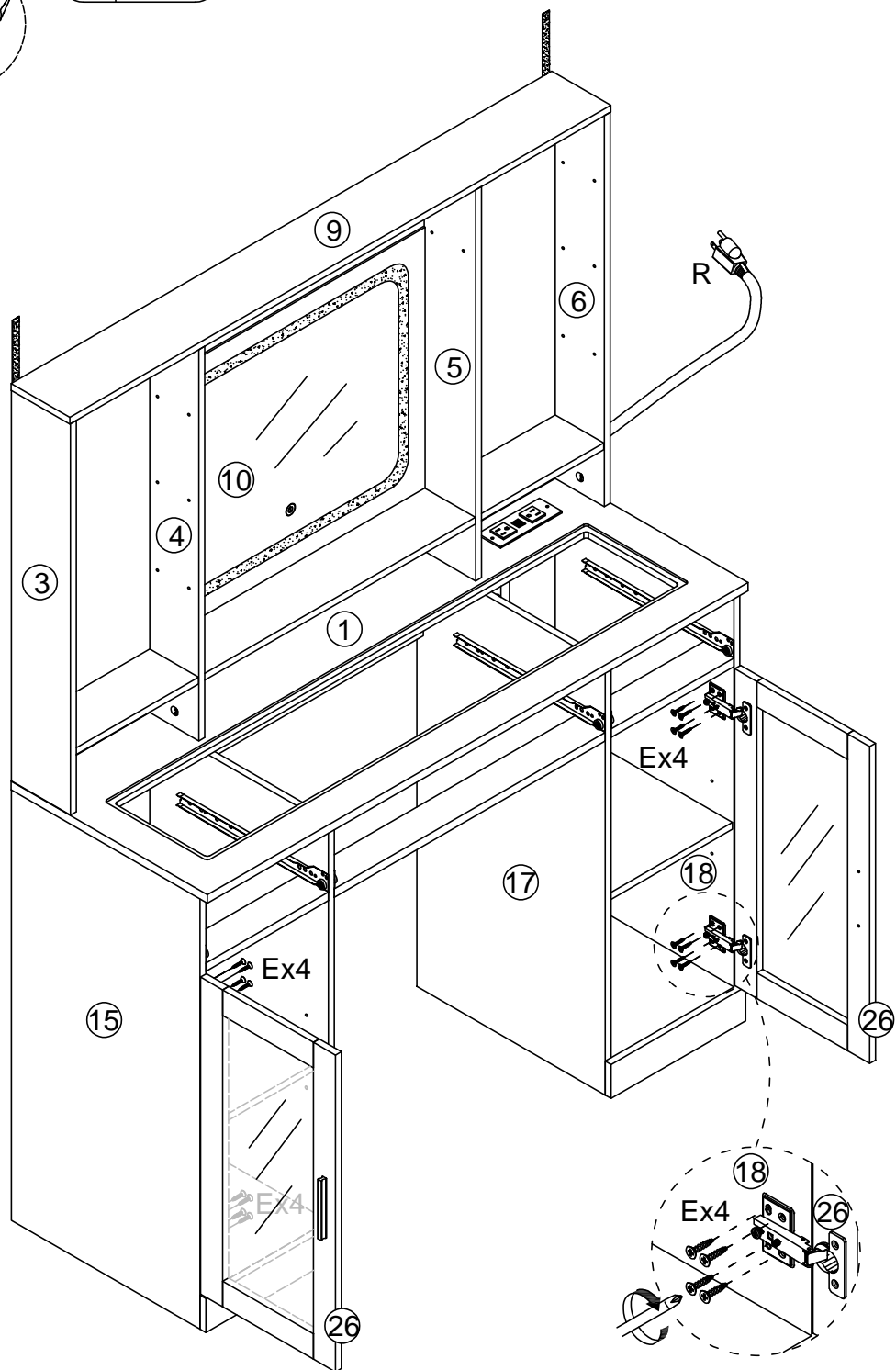
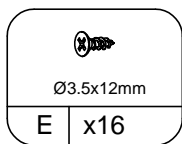
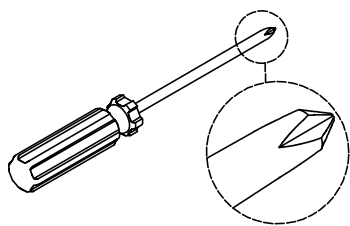



# STEP 26

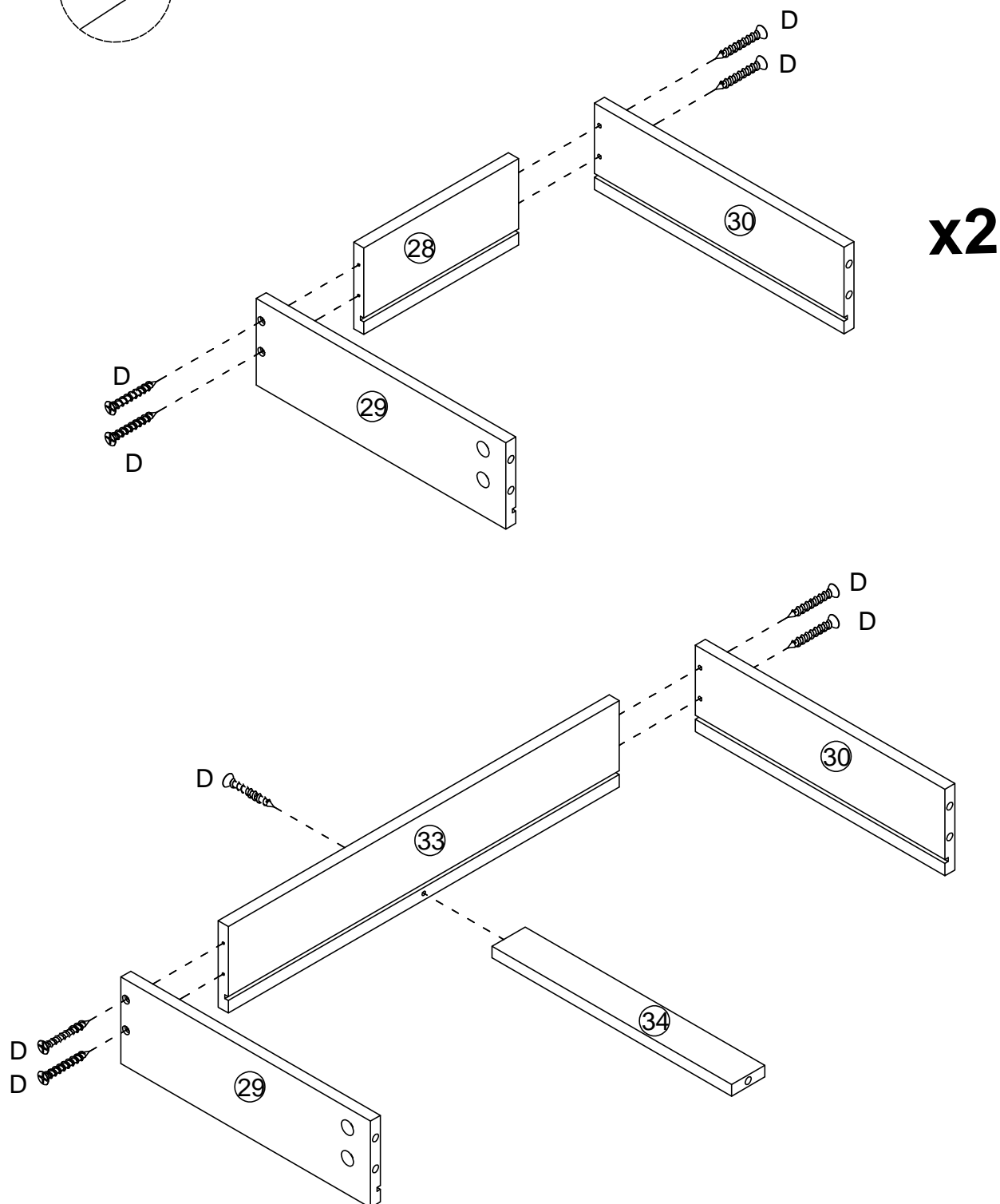
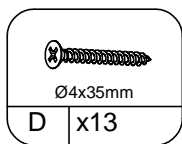
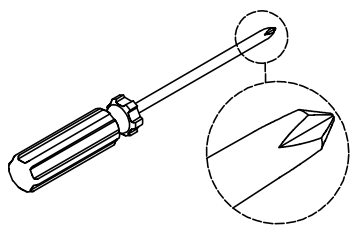

# STEP 27

---

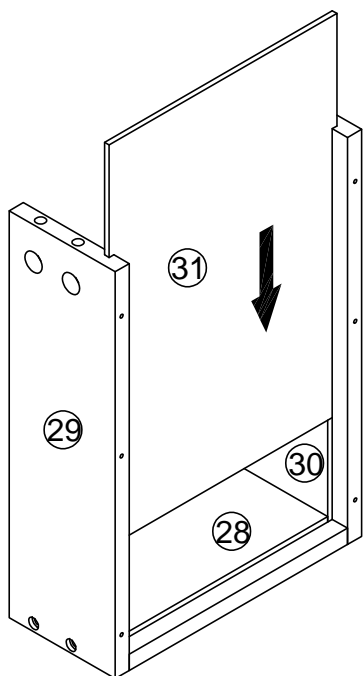

**x2**

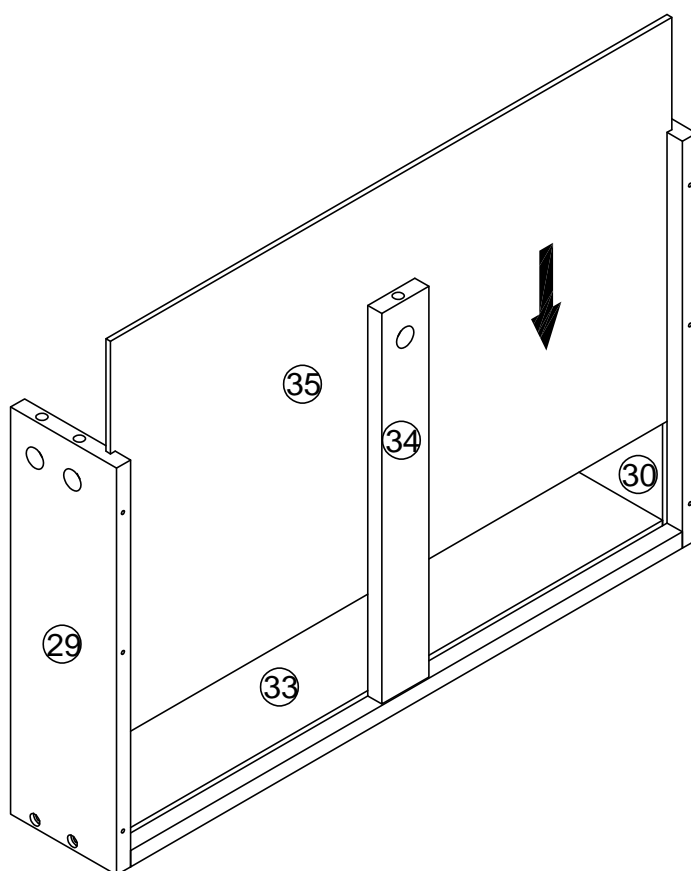

# STEP 28

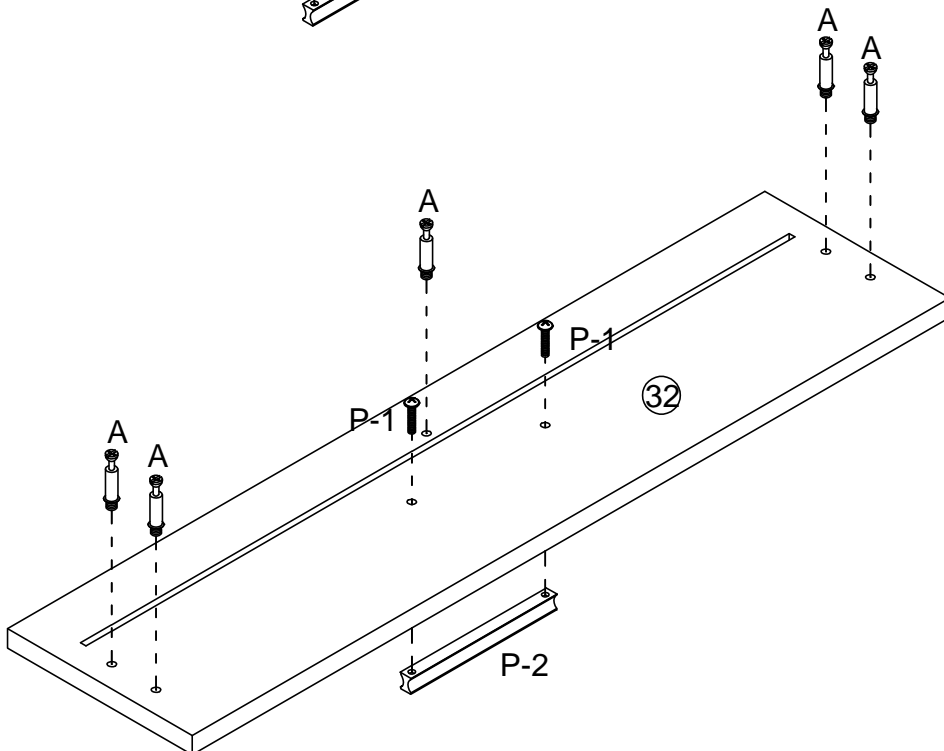
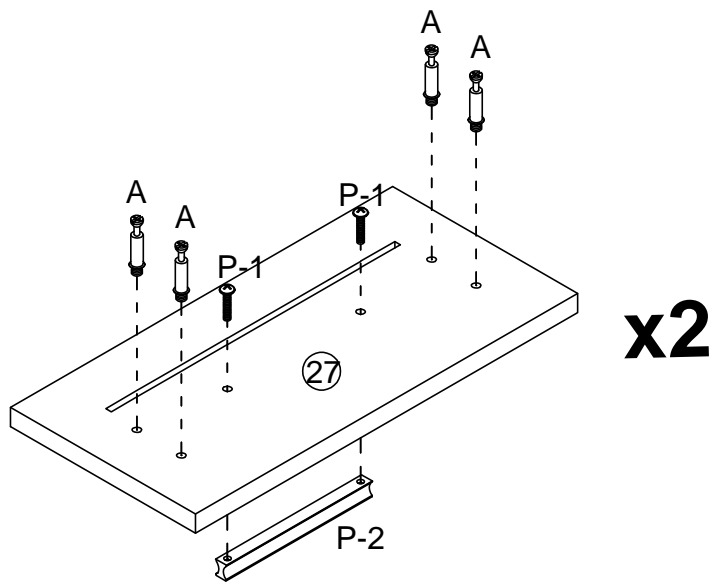
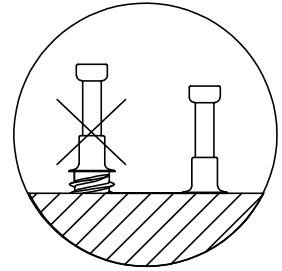
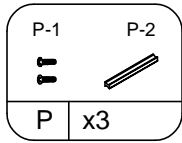
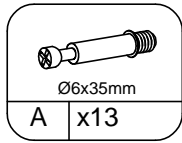
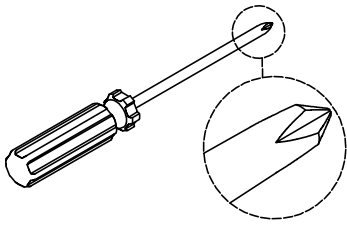

# STEP 29

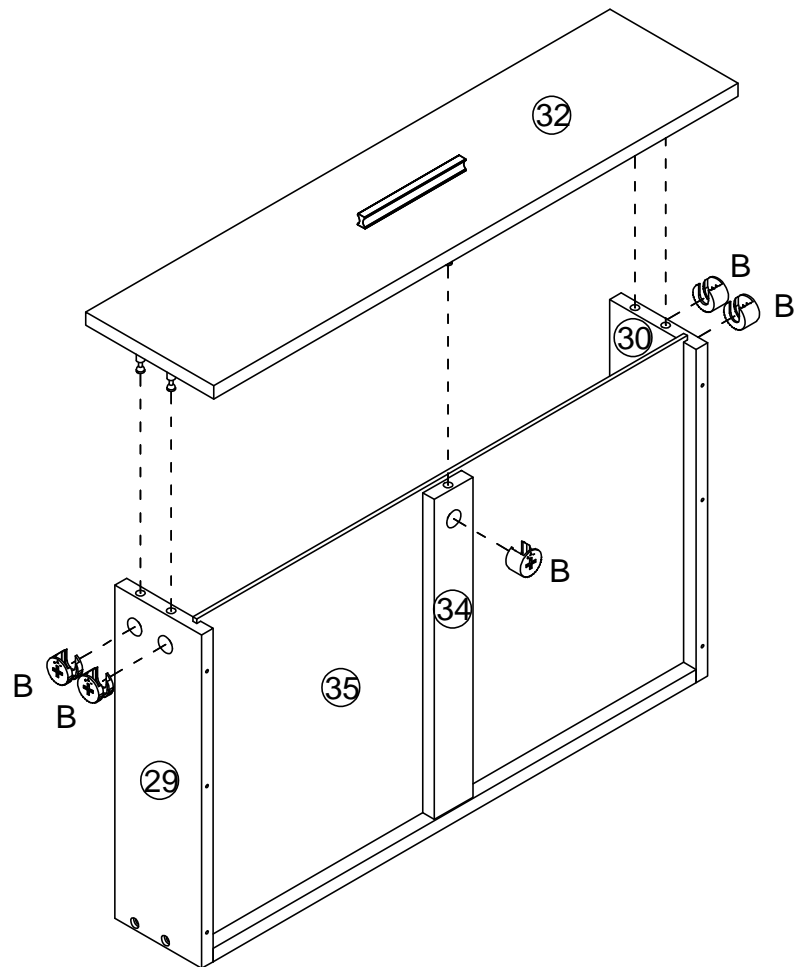
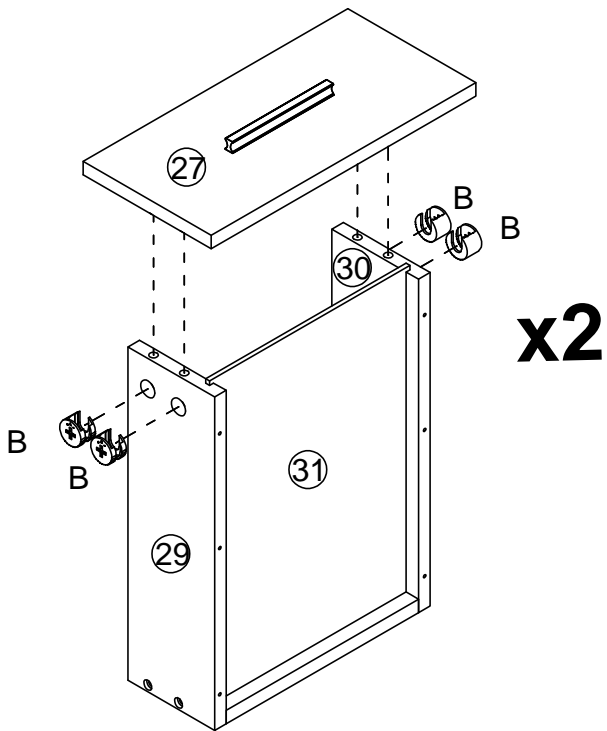
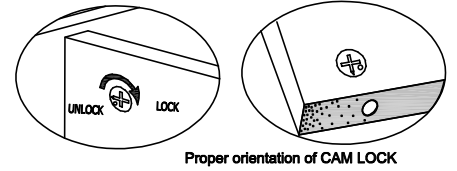
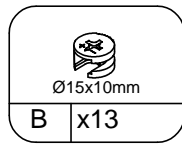
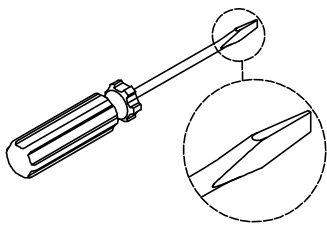

# STEP 30

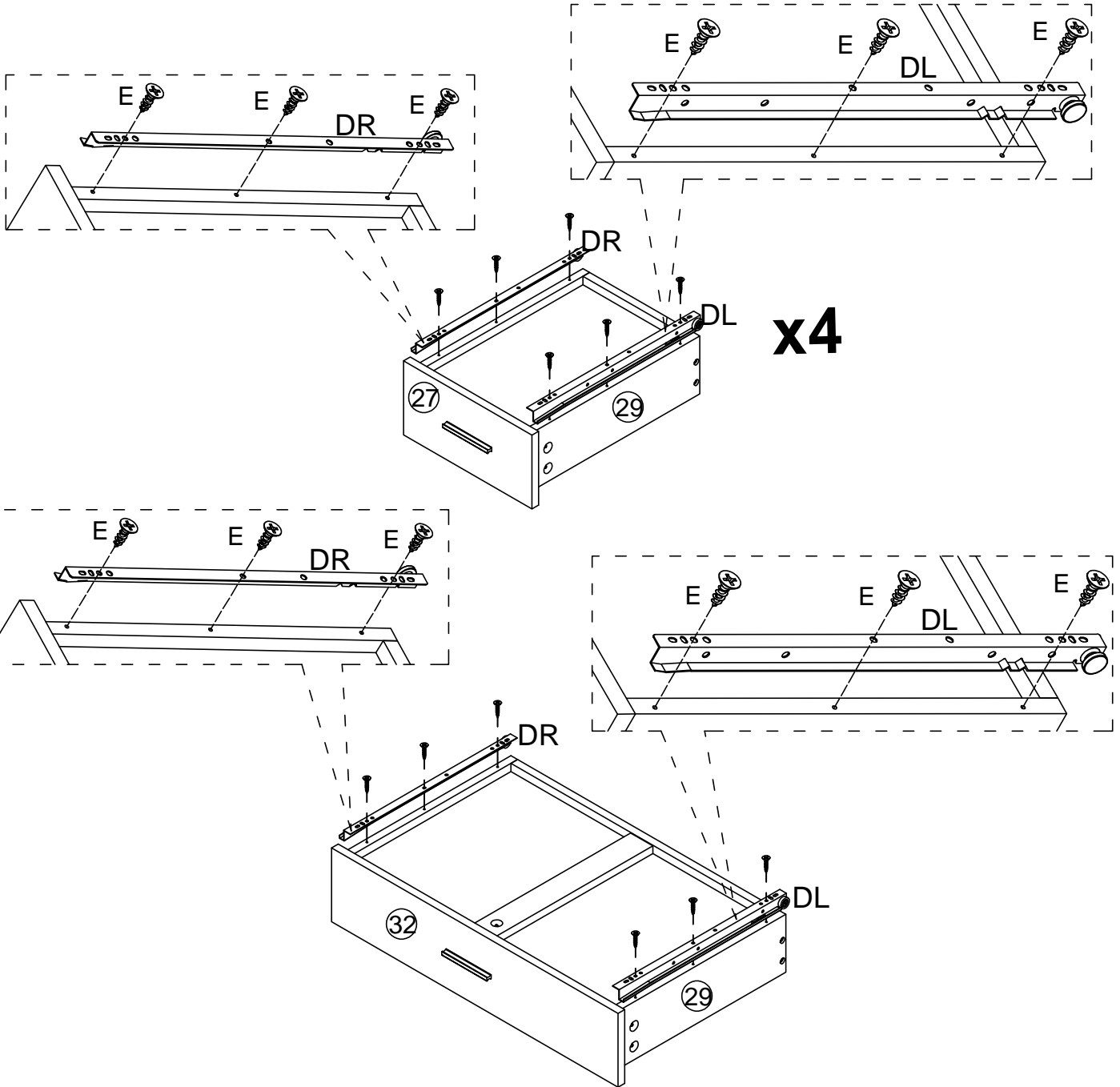
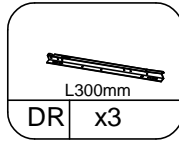
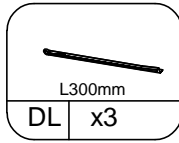
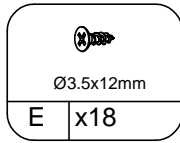
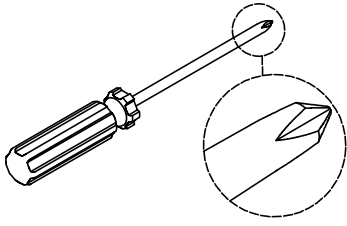

# STEP 31

---

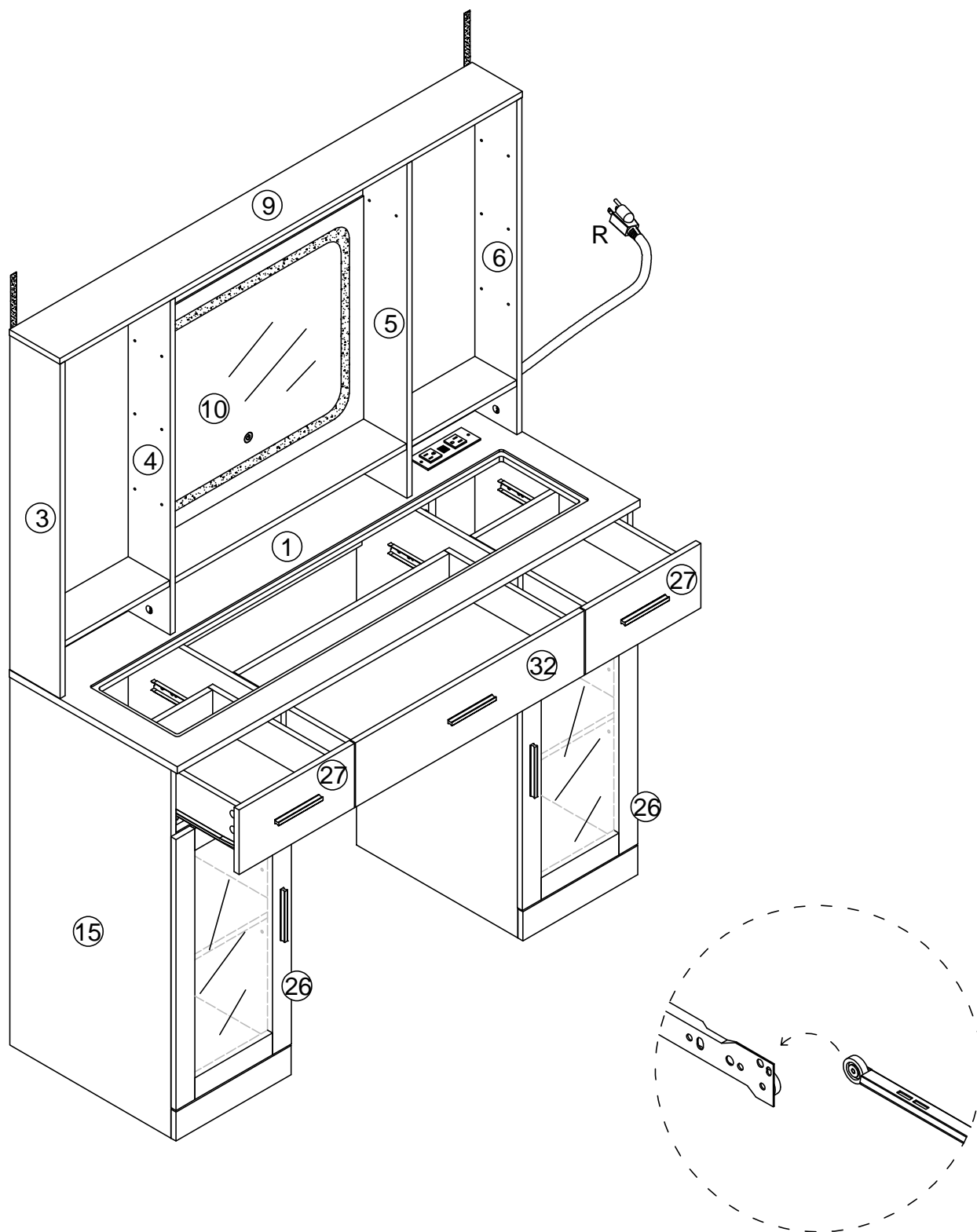

# STEP 32

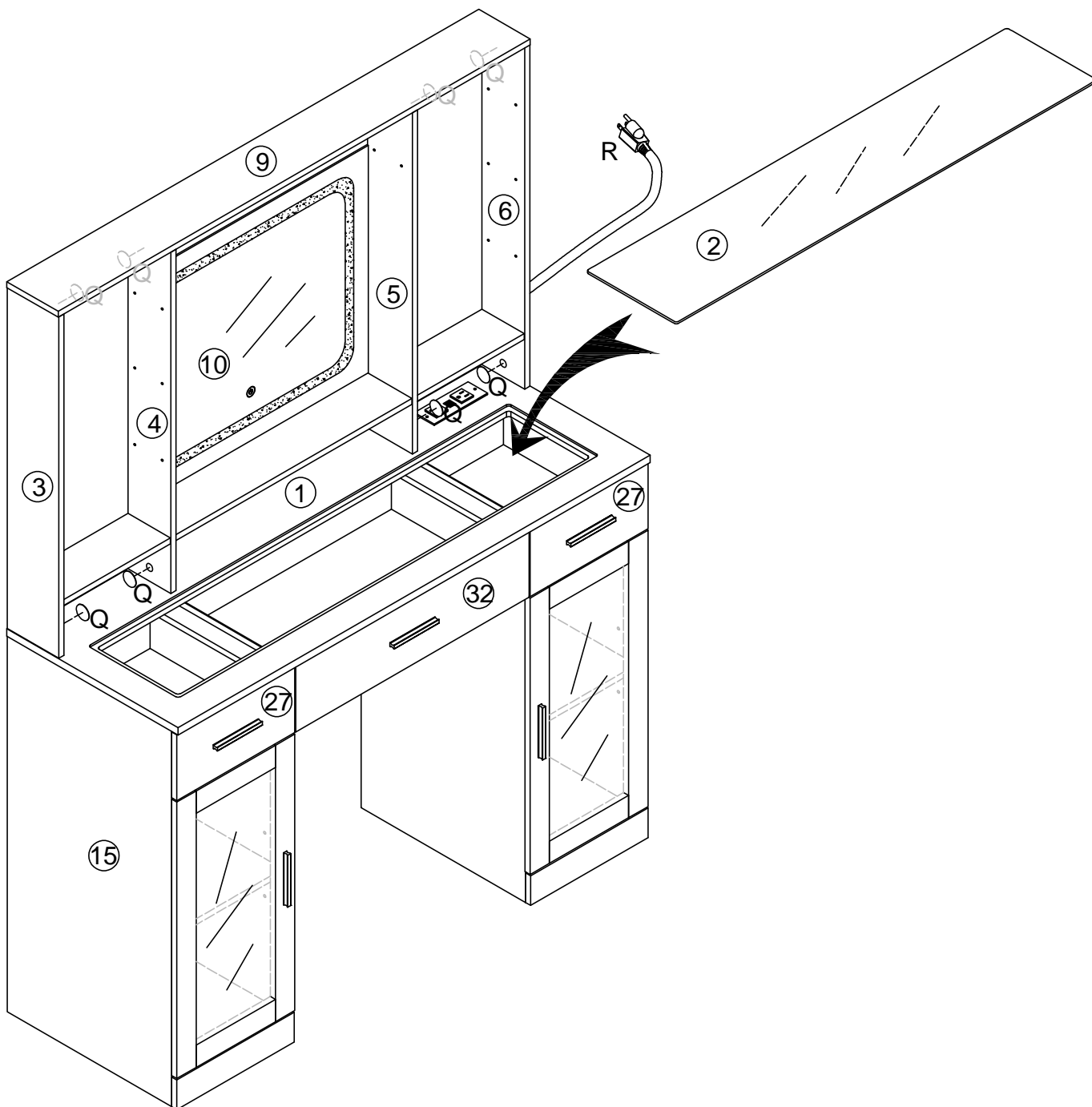
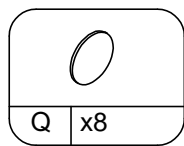

# STEP 33

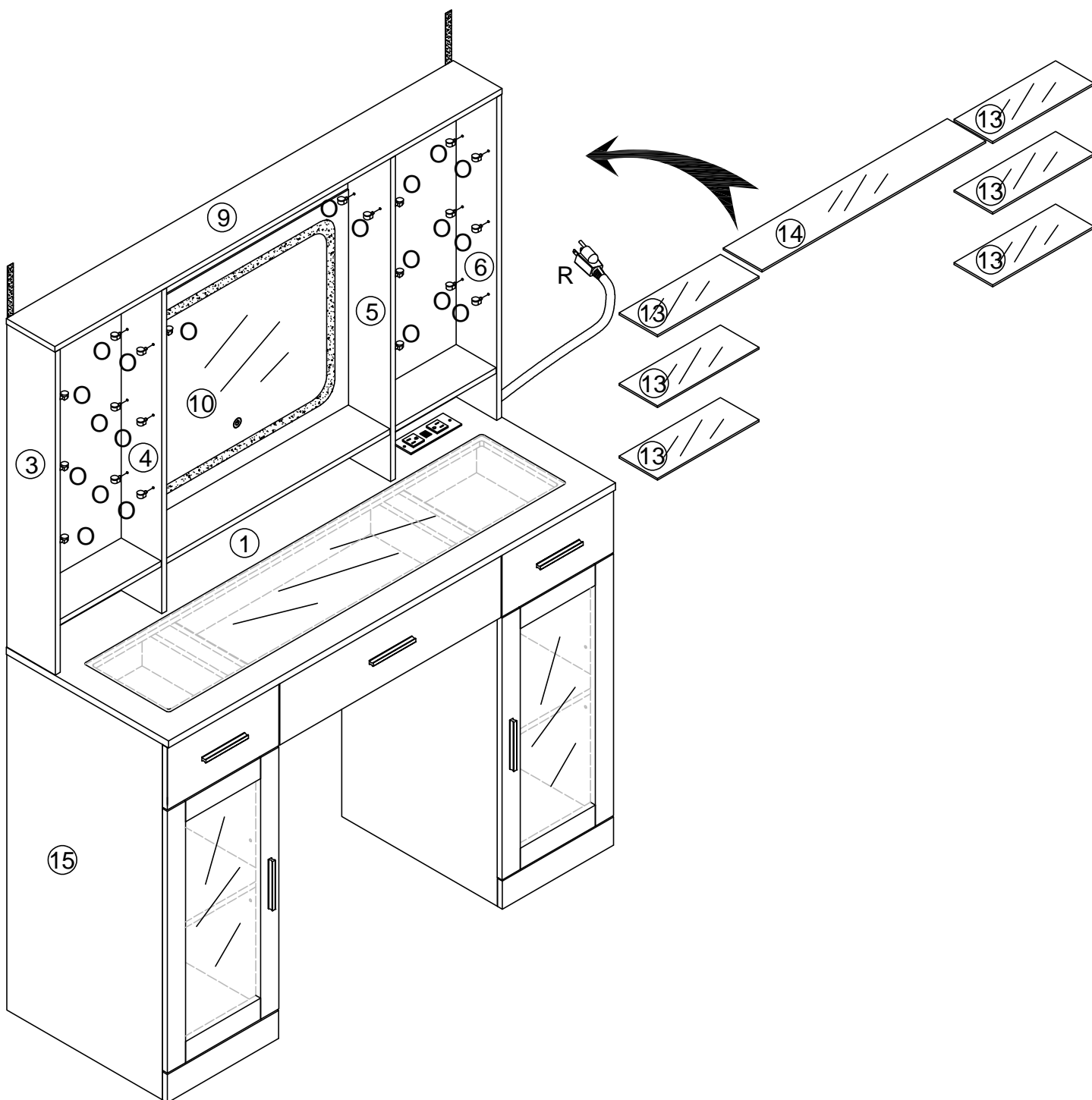
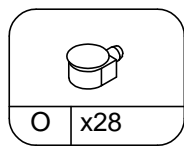



# STEP 34

