

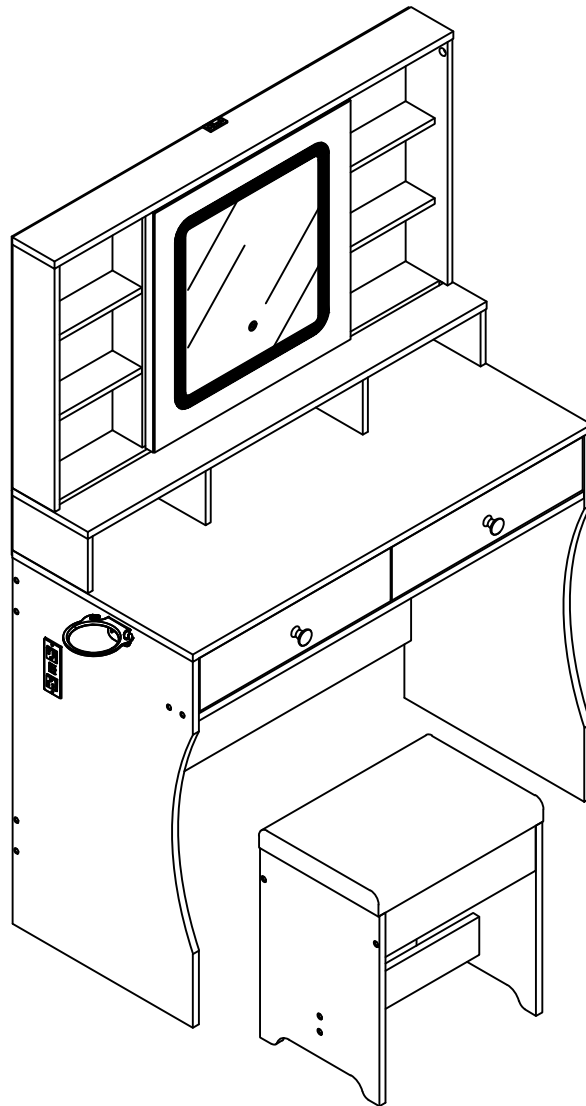

# JY9947BS01



As this item contains many parts, please read the installation instruction carefully before installation . Please use tools properly and carefully. If you have any questions about the product and installation, please contact us.

**[service@vabchesofficial.com](mailto:service@vabchesofficial.com)**

Our professional after-sales team will serve you online all day.

# Before You Start

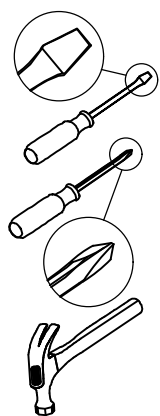

- ✓ Read through each step carefully and follow the proper order
- ✓ Separate and count all your parts and hardware
- ✓ Give yourself enough room for the assembly process
- ✓ Have the following tools: Flat Head Screwdriver, #2 Phillips Head Screwdriver and Hammer
- ✓ Caution: If using a power drill or power screwdriver for screwing, please pay attention to slow down and stop when screw is tight. Failure to do so may result in stripping the screw. (Assembly speed can be increased by using electric screwdriver)

# Helpful Hints

## PEOPLE NEEDED FOR ASSEMBLY:1-2

- Open your item in the area you plan to keep it to avoid excessive heavy lifting.
- Identify, sort and count the parts before attempting assembly.
- Compression dowels are lightly tapped in with a hammer.
- Slides are labeled with an R (right) and L (left) for proper placement.
- Make sure to always face the point on the top of the Cam Lock towards the outer edge.
- If there is a back panel in the package, please install it to make sure your unit is complete and sturdy.
- Please fix all the screws provided for the back panel which can enhance product stability. If it is difficult to fix it when tightening, it can be fixed with the help of a hammer and then tightened.
- Do NOT use harsh chemicals or abrasive cleaners on this item.
- Never push, pull, or drag your furniture.

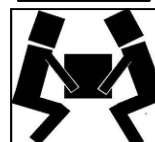
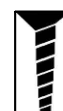
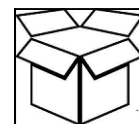

# Board Identification

Not actual size

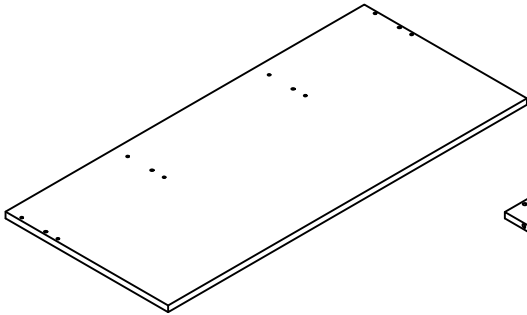

Ⓐ

TOP  
Qty:1

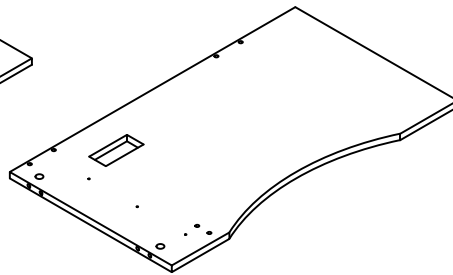

Ⓑ

LEFT SIDE PANEL  
Qty:1

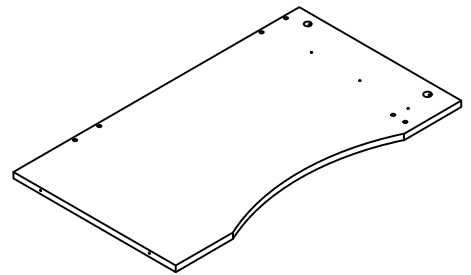

Ⓒ

RIGHT SIDE PANEL  
Qty:1

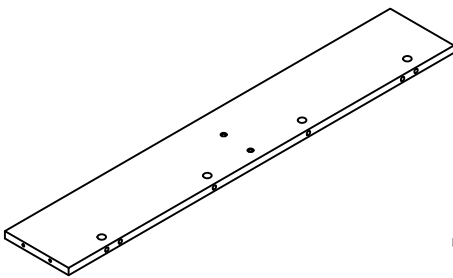

Ⓓ

BACK SLAT  
Qty:1

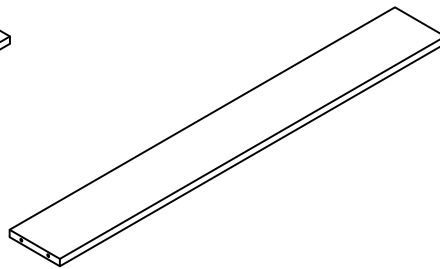

Ⓔ

LOWER BACK SLAT  
Qty:1

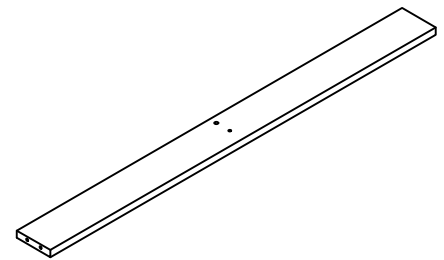

Ⓕ

LEFT FRONT SLAT  
Qty:1

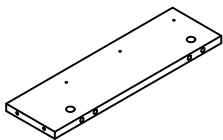

Ⓖ

MIDDLE PANEL  
Qty:1

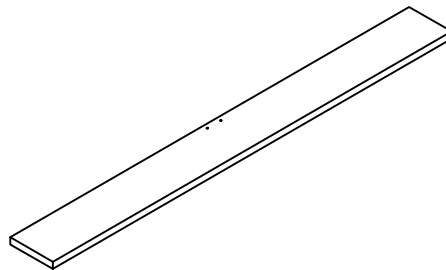

Ⓖ

FIXED SHELF  
Qty:1

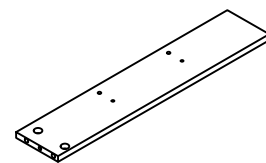

Ⓖ

UPPER LEFT SIDE PANEL  
Qty:1

# Board Identification

Not actual size

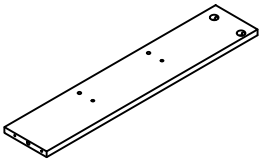

(J)

UPPER RIGHT SIDE PANEL  
Qty:1

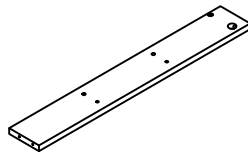

(K)

UPPER LEFT MIDDLE PANEL  
Qty:1

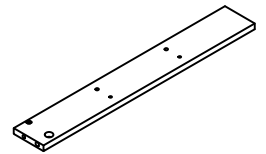

(L)

UPPER RIGHT MIDDLE PANEL  
Qty:1

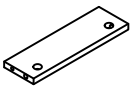

(M)

FIXED SHELF  
Qty:4

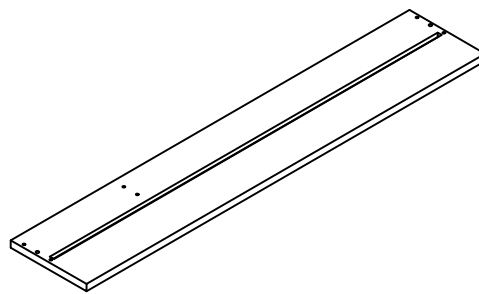

(N)

HUTCH FIXED SHELF  
Qty:1

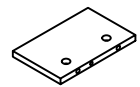

(O)

HUTCH SIDE PANEL  
Qty:2

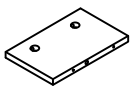

(P)

HUTCH SIDE PANEL  
Qty:2

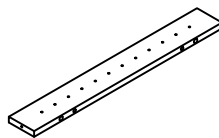

(Q)

HUTCH FIXED SHELF  
Qty:1

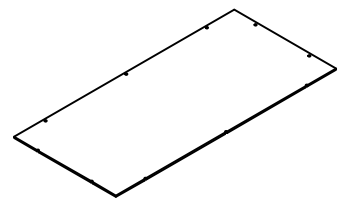

(R)

DESK BACK PANEL  
Qty:1



# Board Identification

Not actual size

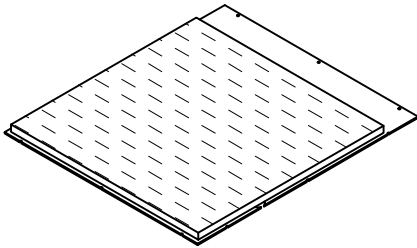

Ⓢ

DESK BACK PANEL  
Qty:1

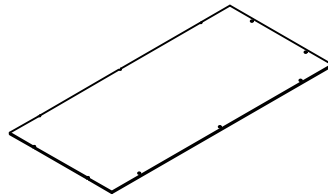

Ⓣ

DESK BACK PANEL  
Qty:1

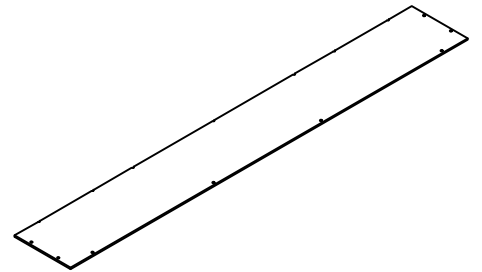

Ⓤ

DESK BACK PANEL  
Qty:1

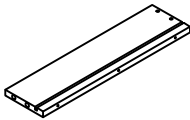

Ⓥ

DRAWER LEFT SIDE  
Qty:2

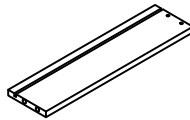

Ⓦ

DRAWER RIGHT SIDE  
Qty:2

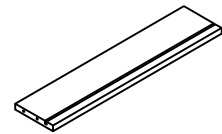

Ⓧ

DRAWER BACK PANEL  
Qty:2

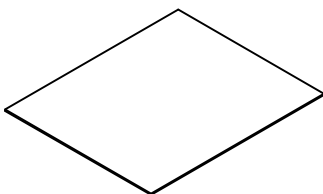

Ⓨ

DRAWER BOTTOM  
Qty:2

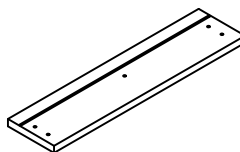

Ⓩ

LEFT DRAWER FRONT  
Qty:1

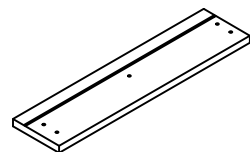

ⒶⒶ

RIGHT DRAWER FRONT  
Qty:1

# Board Identification

Not actual size

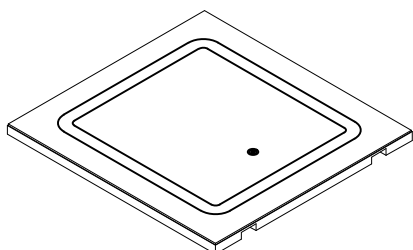

ⓑ

DRESSING MIRROR  
Qty:1

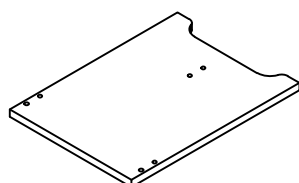

ⓒ

STOOL SIDE PANEL  
Qty:2

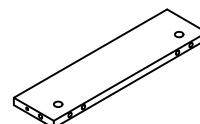

ⓓ

STOOL APRON  
Qty:2

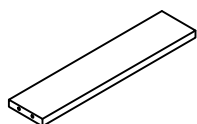

ⓔ

STOOL LOWER SLAT  
Qty:1

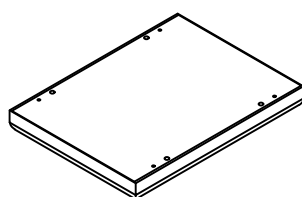

ⓕ

SPONGE CUSHION  
Qty:1

# Part List

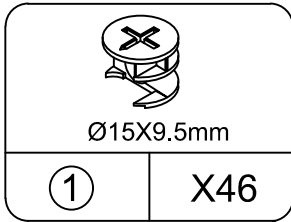

CAM LOCK  
spare:3

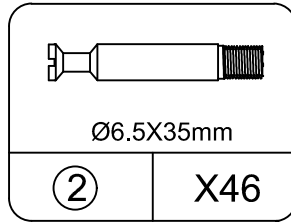

CAM BOLT  
spare:3

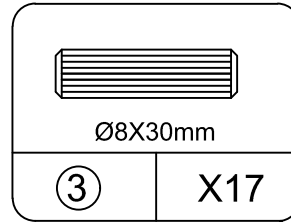

WOOD DOWEL  
spare:1

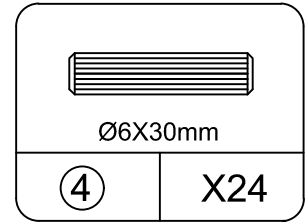

WOOD DOWEL  
spare:2

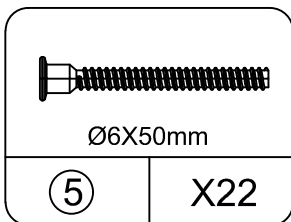

SCREW  
spare:2

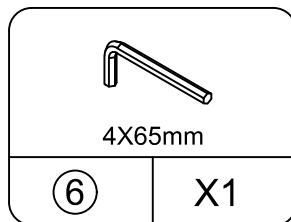

HEX KEY

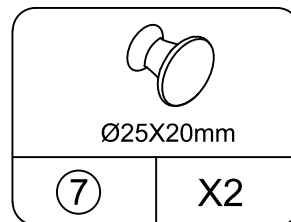

HANDLE

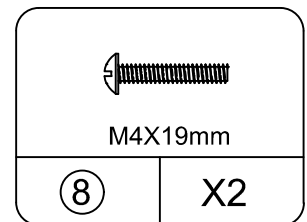

SCREW  
spare:1

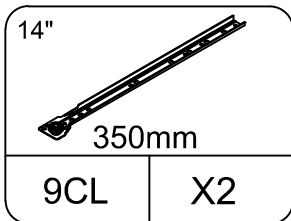

LEFT CABINET MEMBER

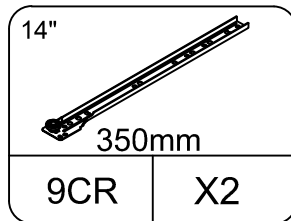

RIGHT CABINET MEMBER

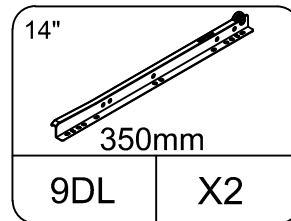

LEFT DRAWER RUNNER

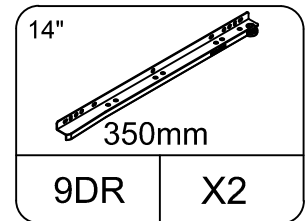

RIGHT DRAWER RUNNER

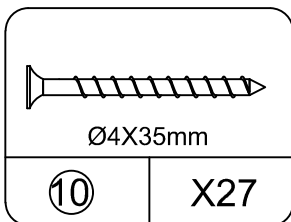

SCREW  
spare:2

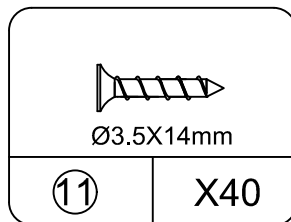

SCREW  
spare:3

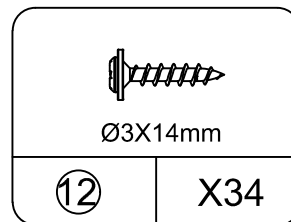

SCREW  
spare:3

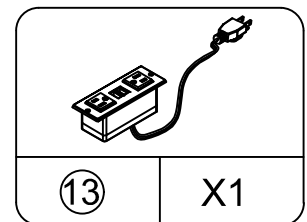

POWER STRIP

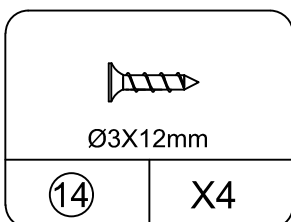

SCREW  
spare:1

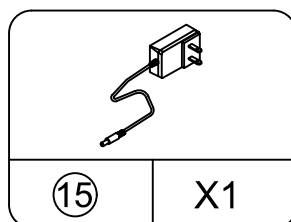

POWER PLUG

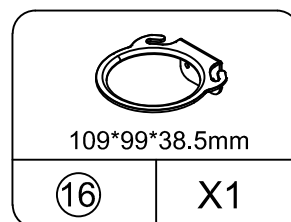

HAIR DRYER RACK

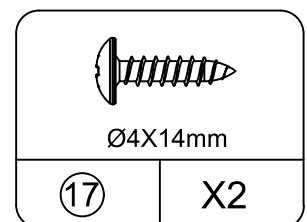

SCREW  
spare:1

# Part List

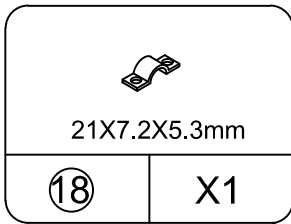

THREAD CLASP

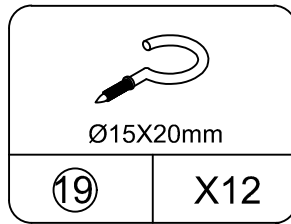

HOOKING

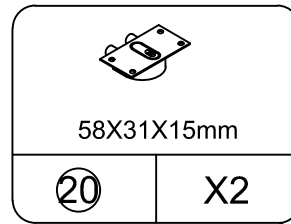

PULLEY

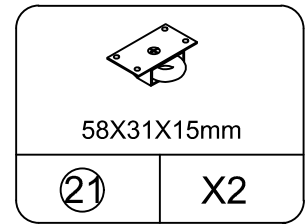

PULLEY

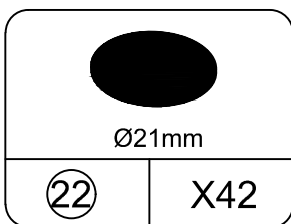

PERFECT STICKER  
spare:3

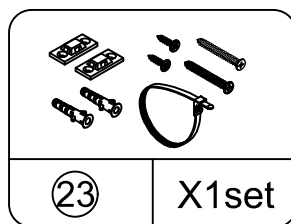

HIPPING RESTRAINT  
HARDWARE KIT

## Cam Lock Fastening System

Insert the cam bolt into the hole first, then insert the cam lock and lock it.

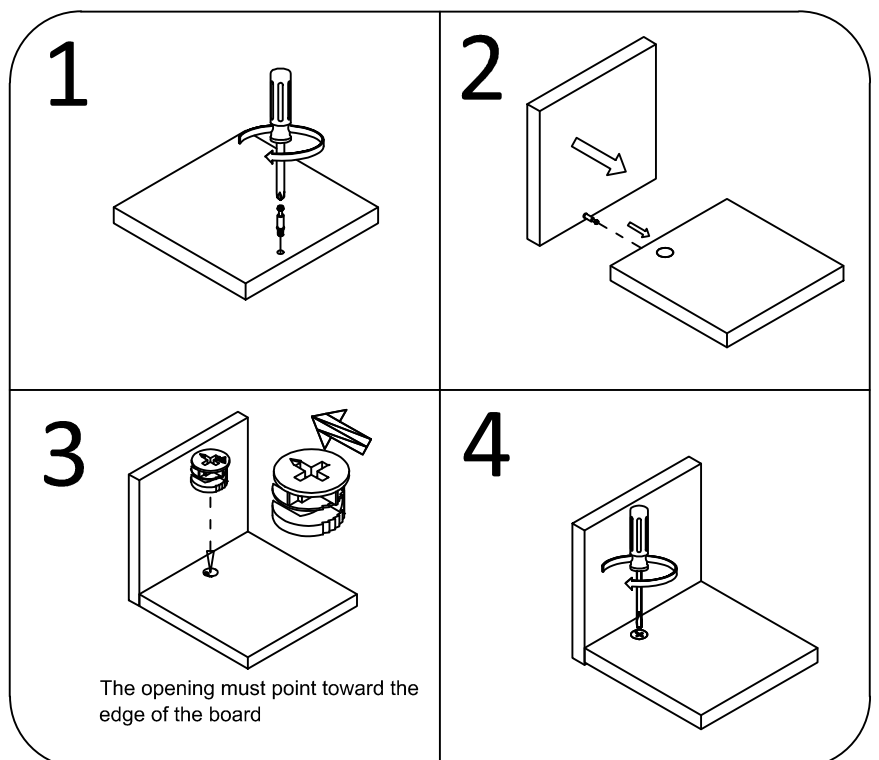

# Board Identification

Not actual size

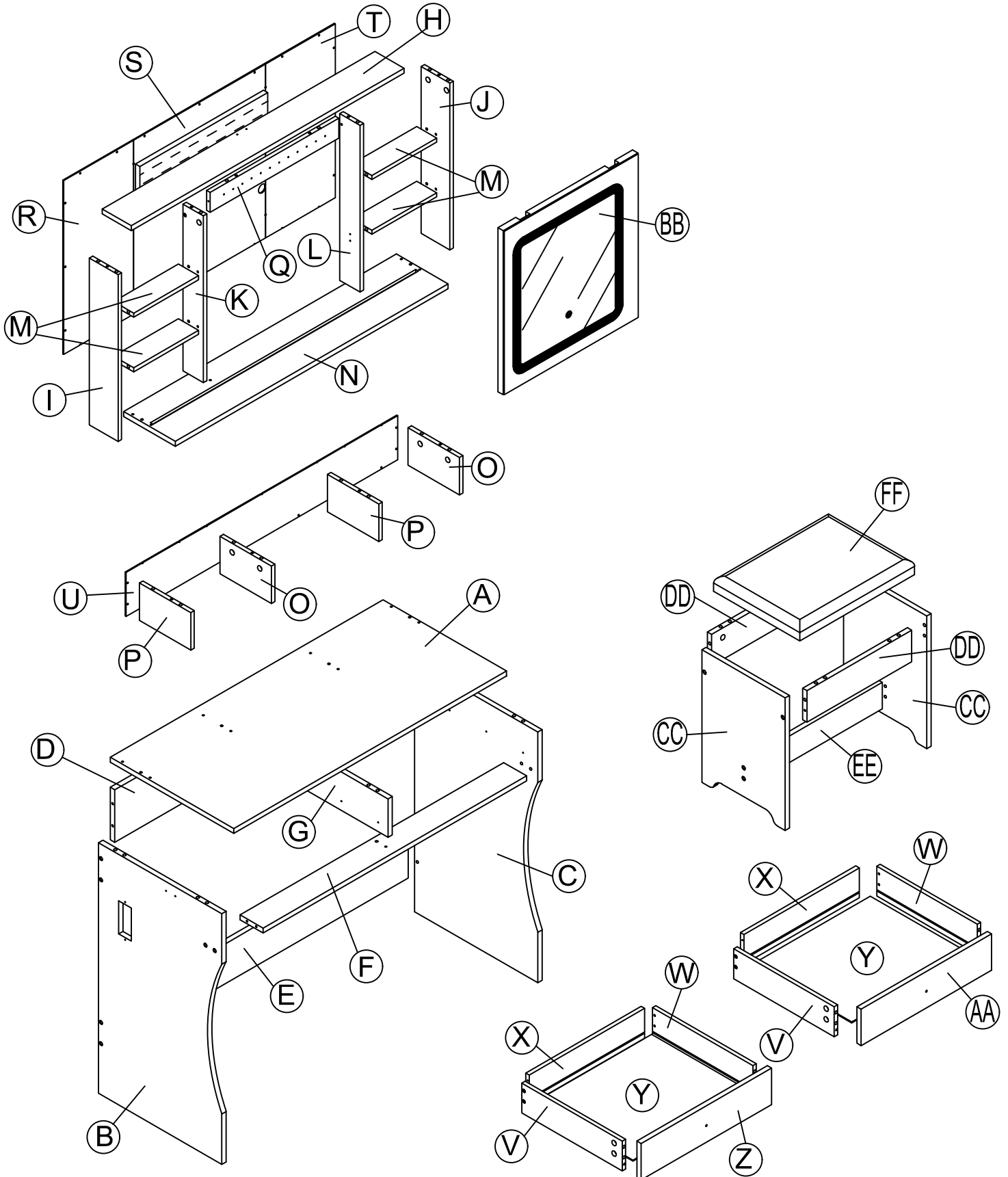

# STEP 1

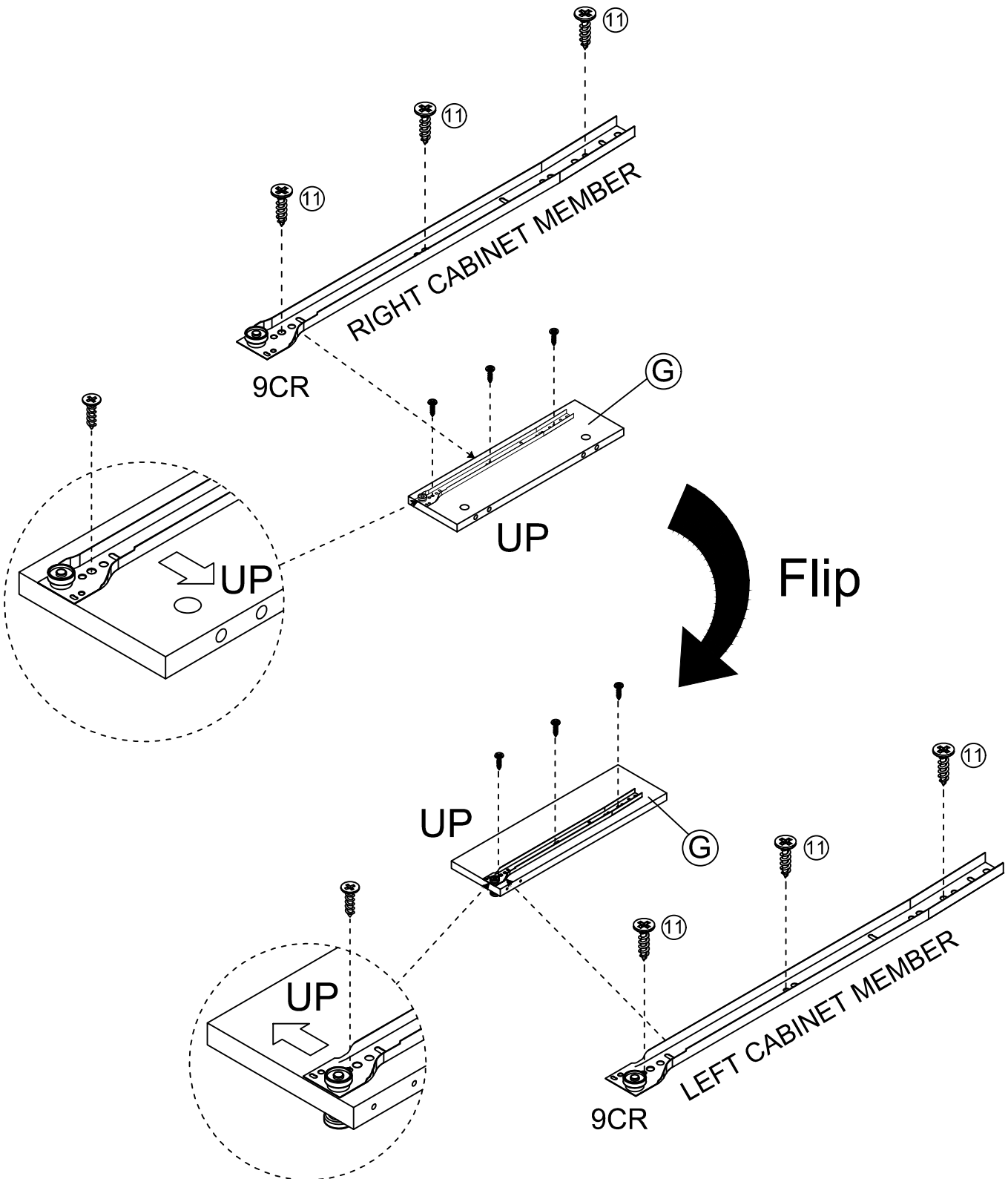
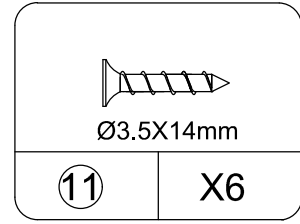
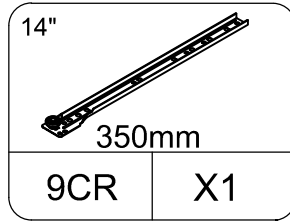
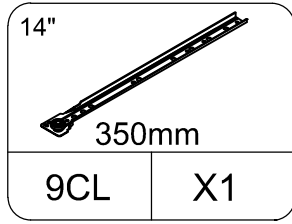
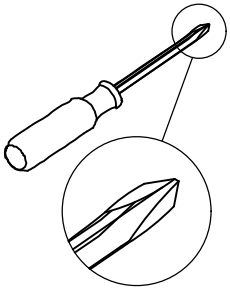

# STEP 2

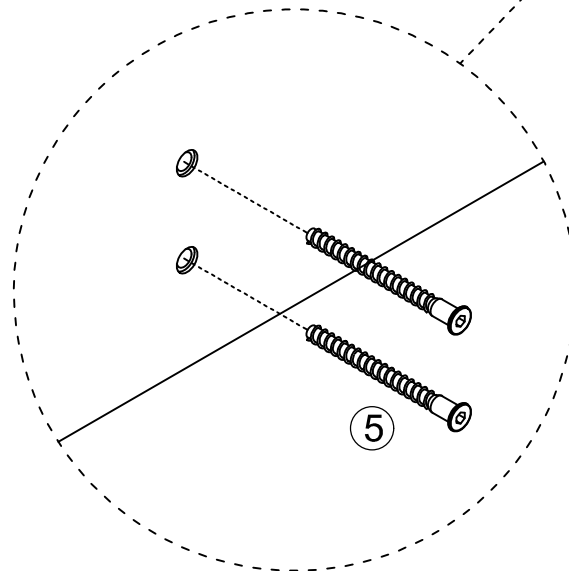
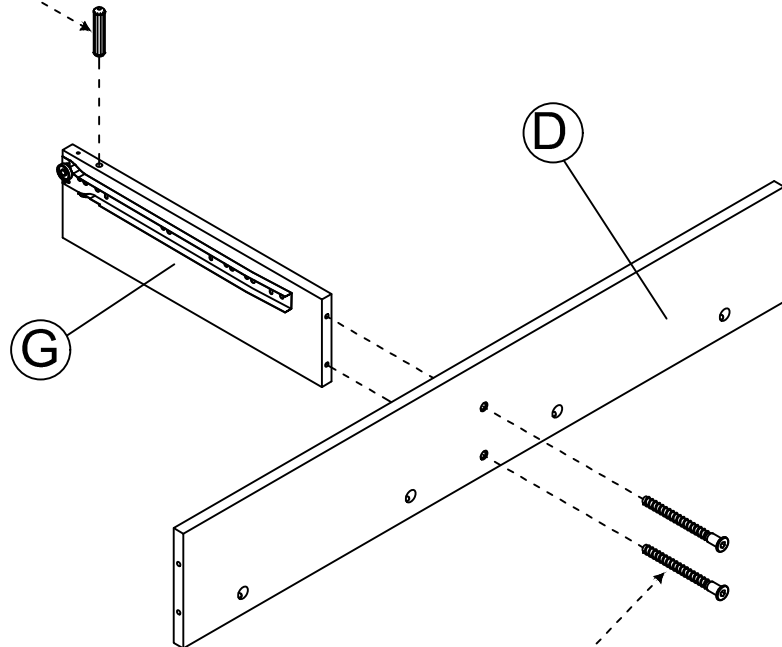
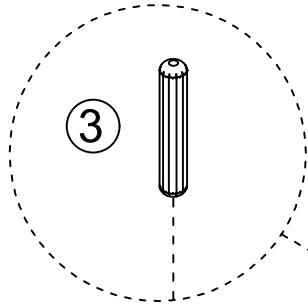
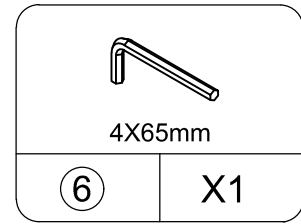
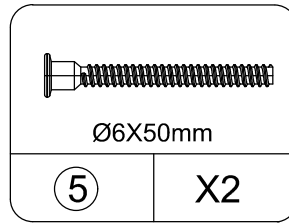
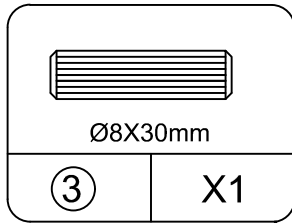
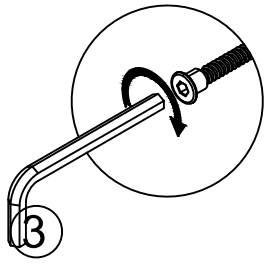

# STEP 3

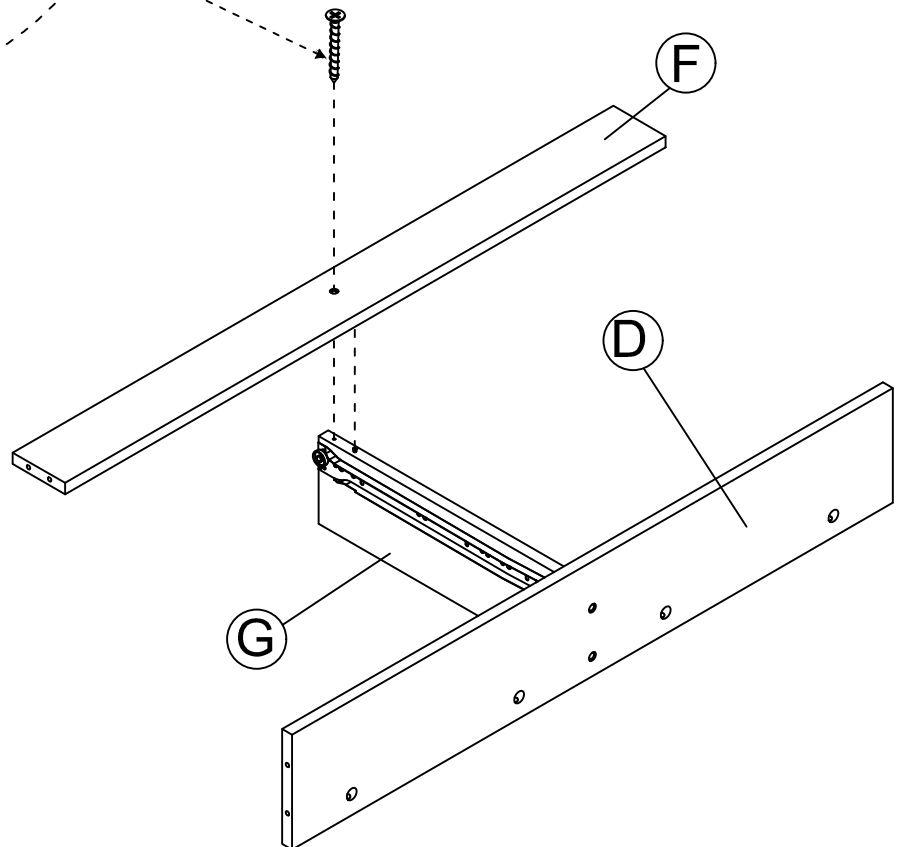
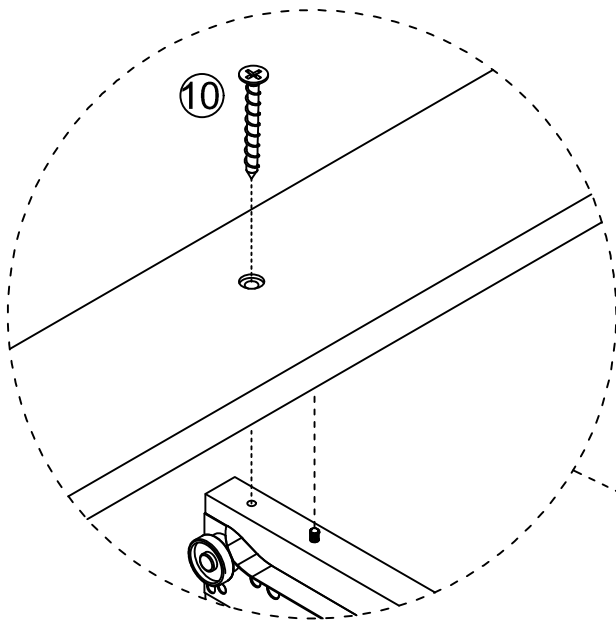
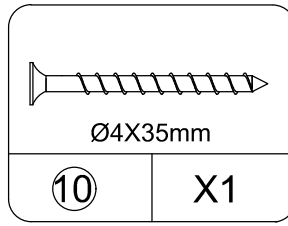
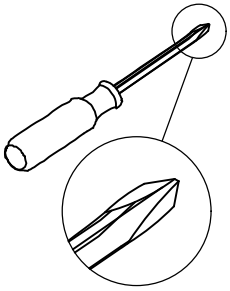



# STEP 4

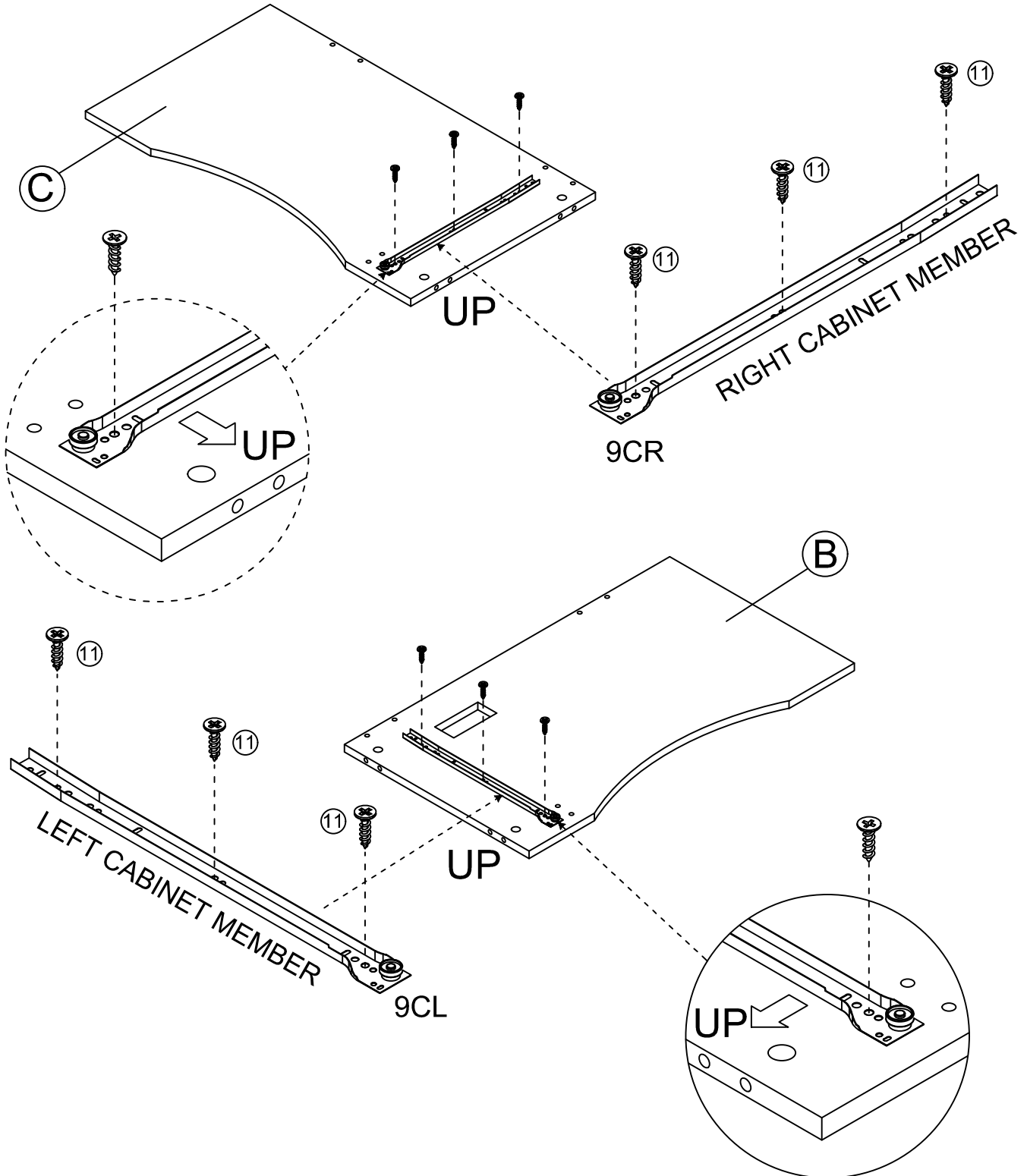
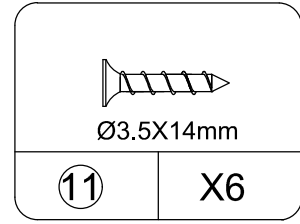
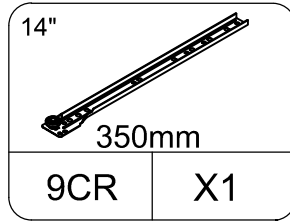
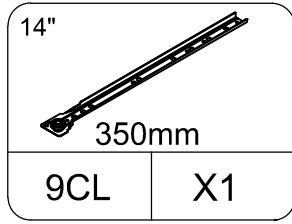
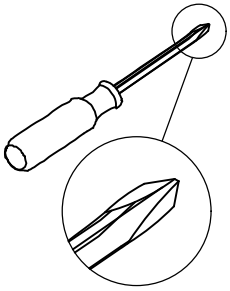

# STEP5

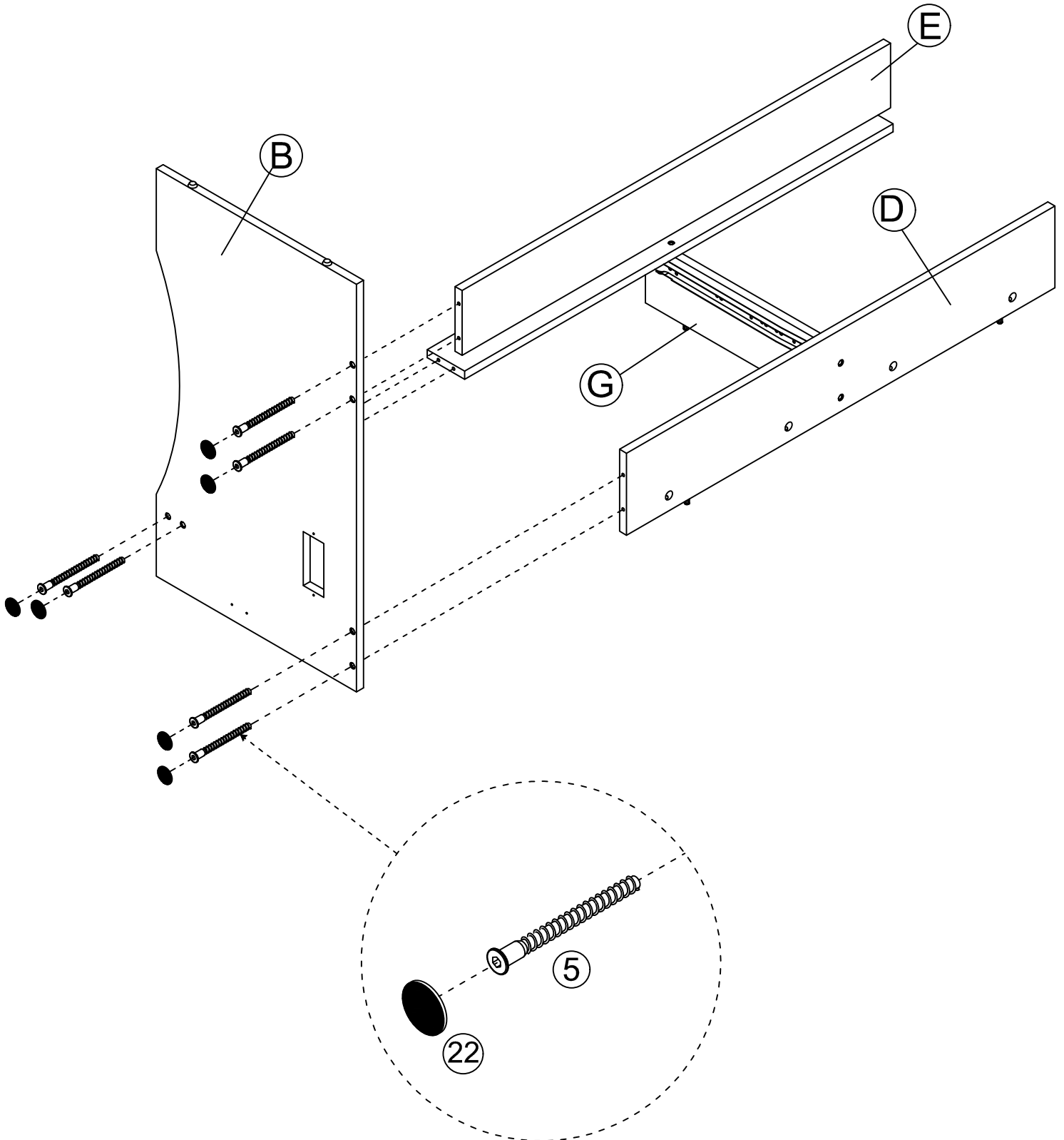
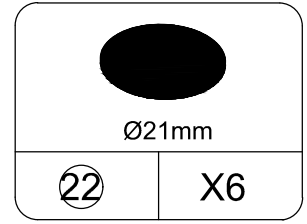
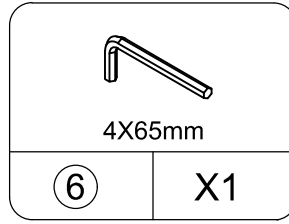
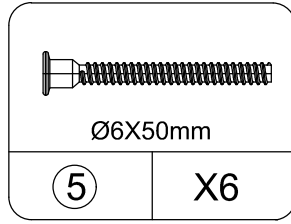
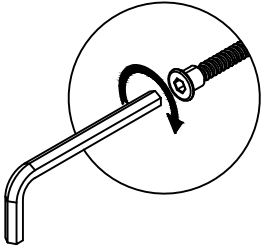

# STEP 6

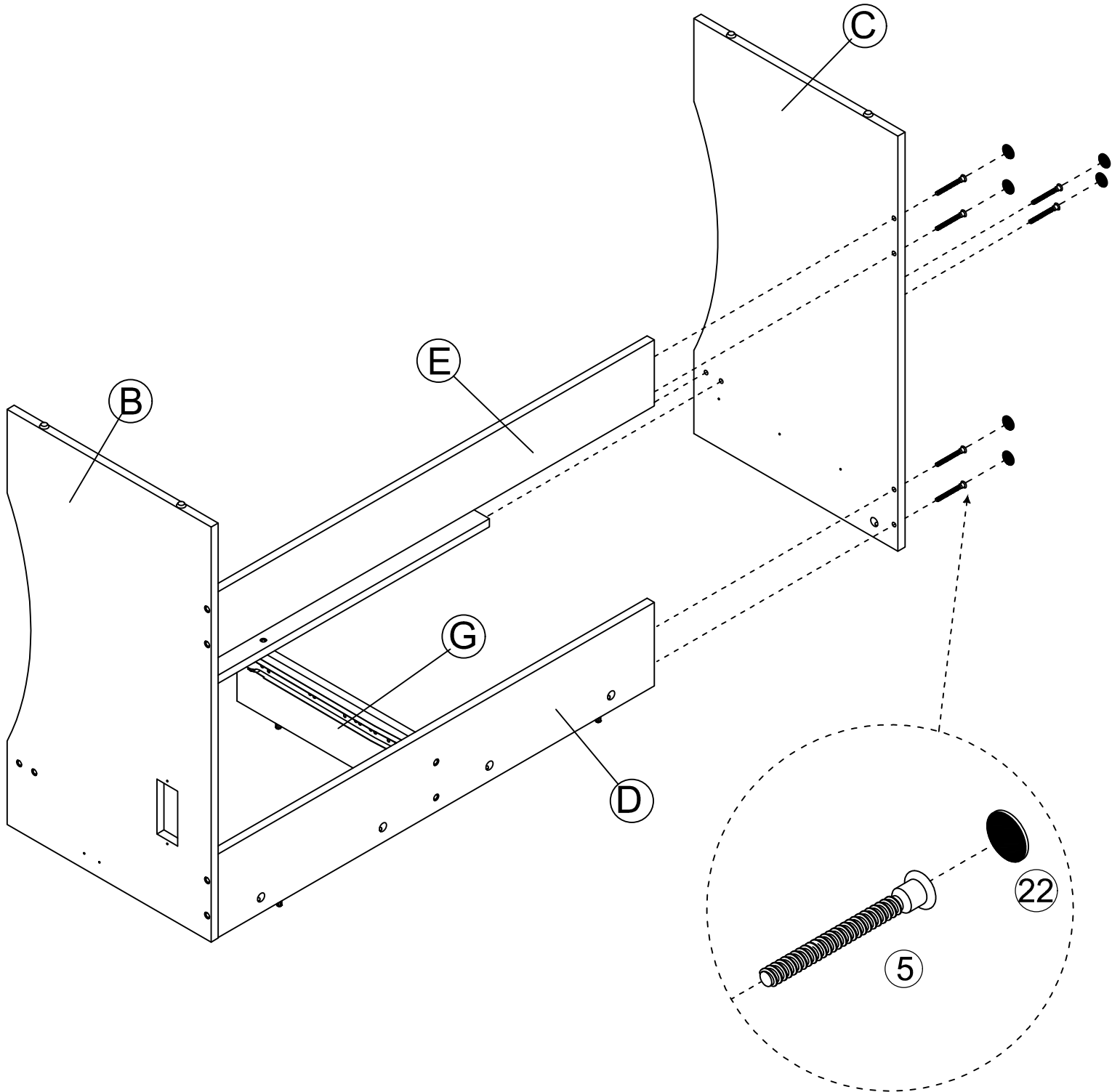
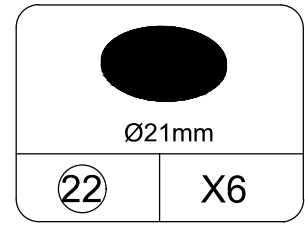
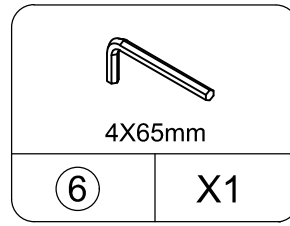
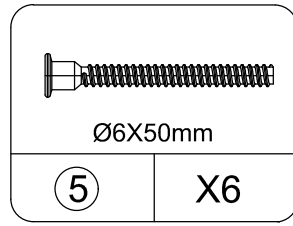
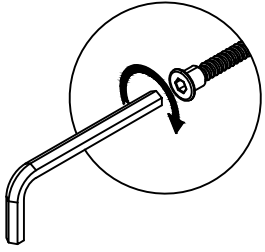

# STEP 7

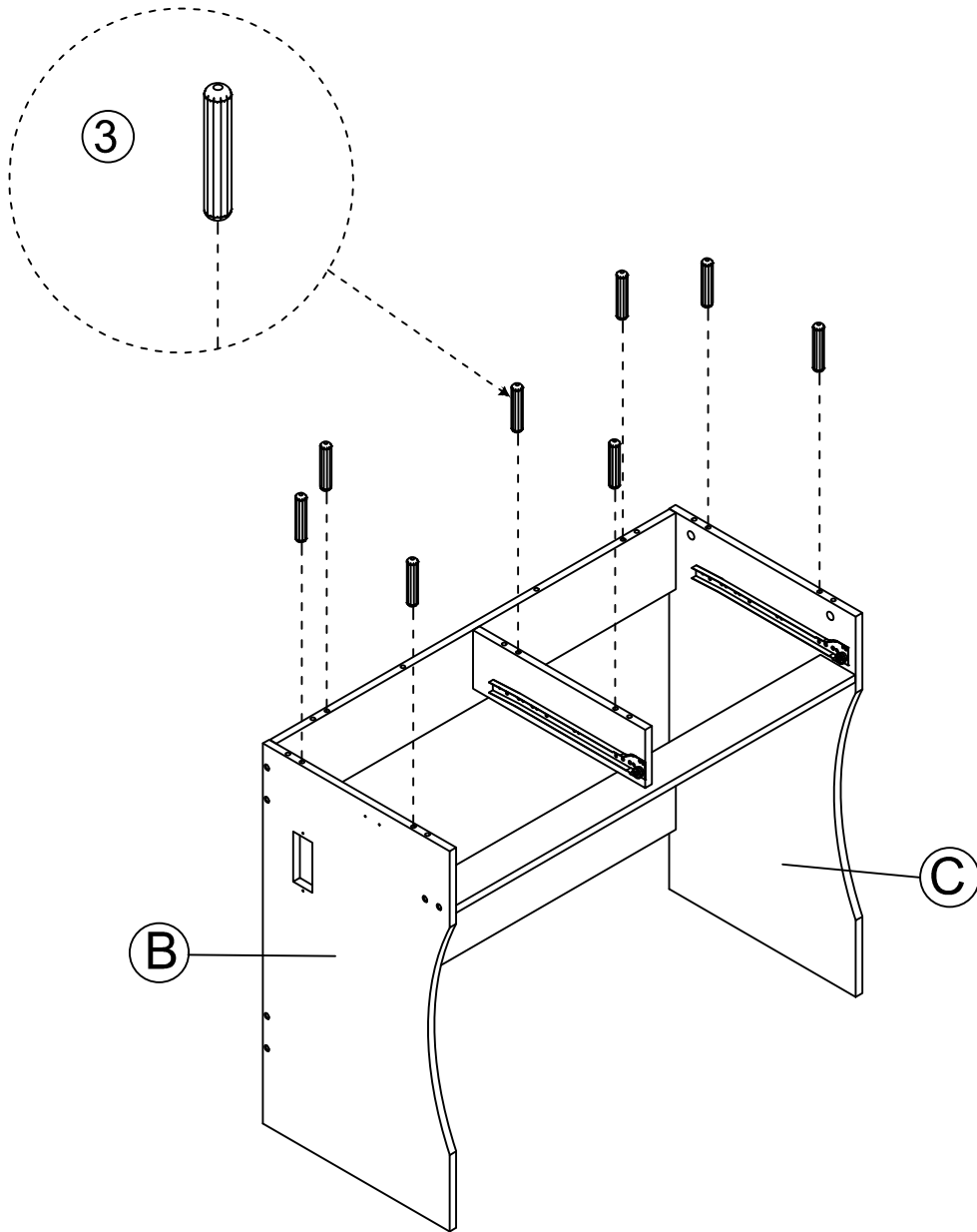
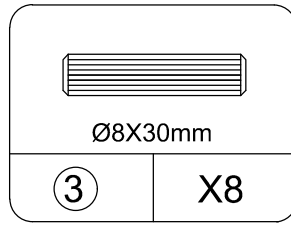
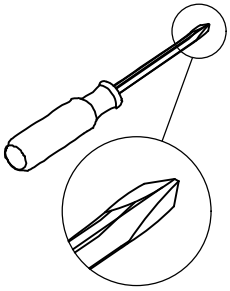

# STEP 8

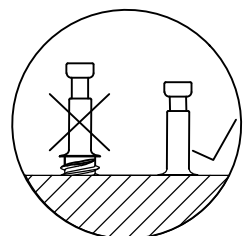
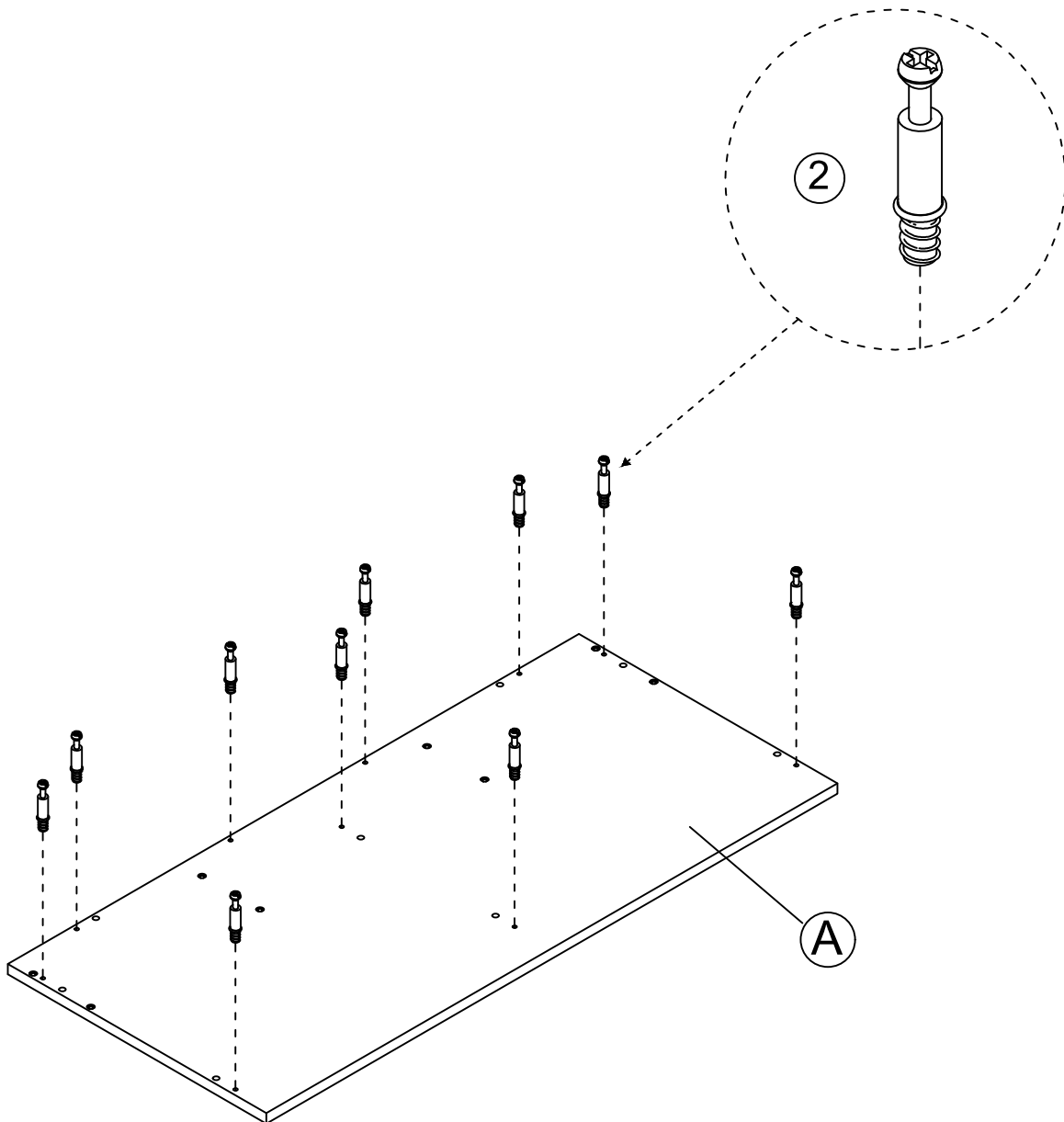
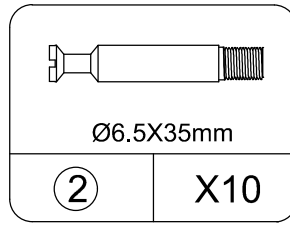
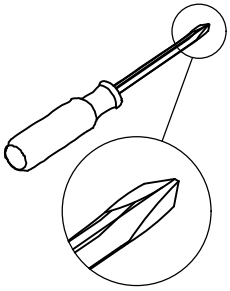

# STEP9

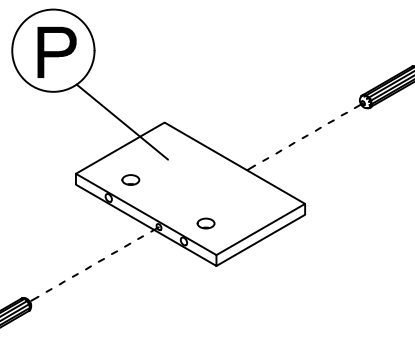
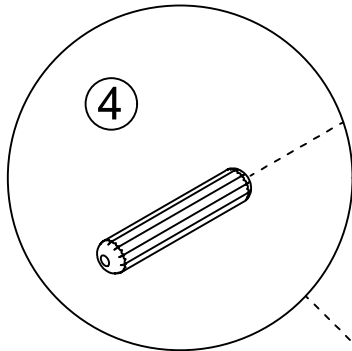
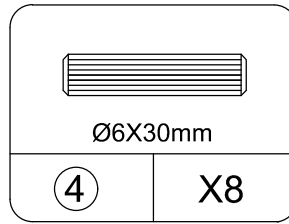
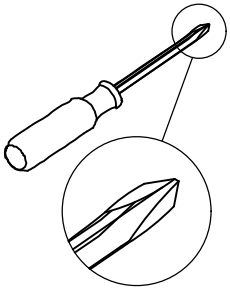

X2

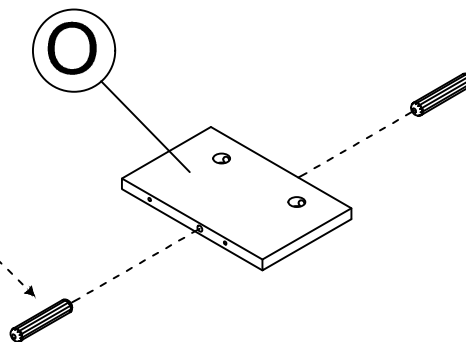
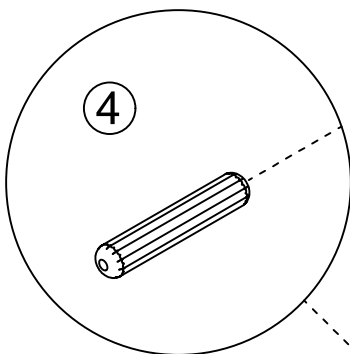

X2

# STEP 10

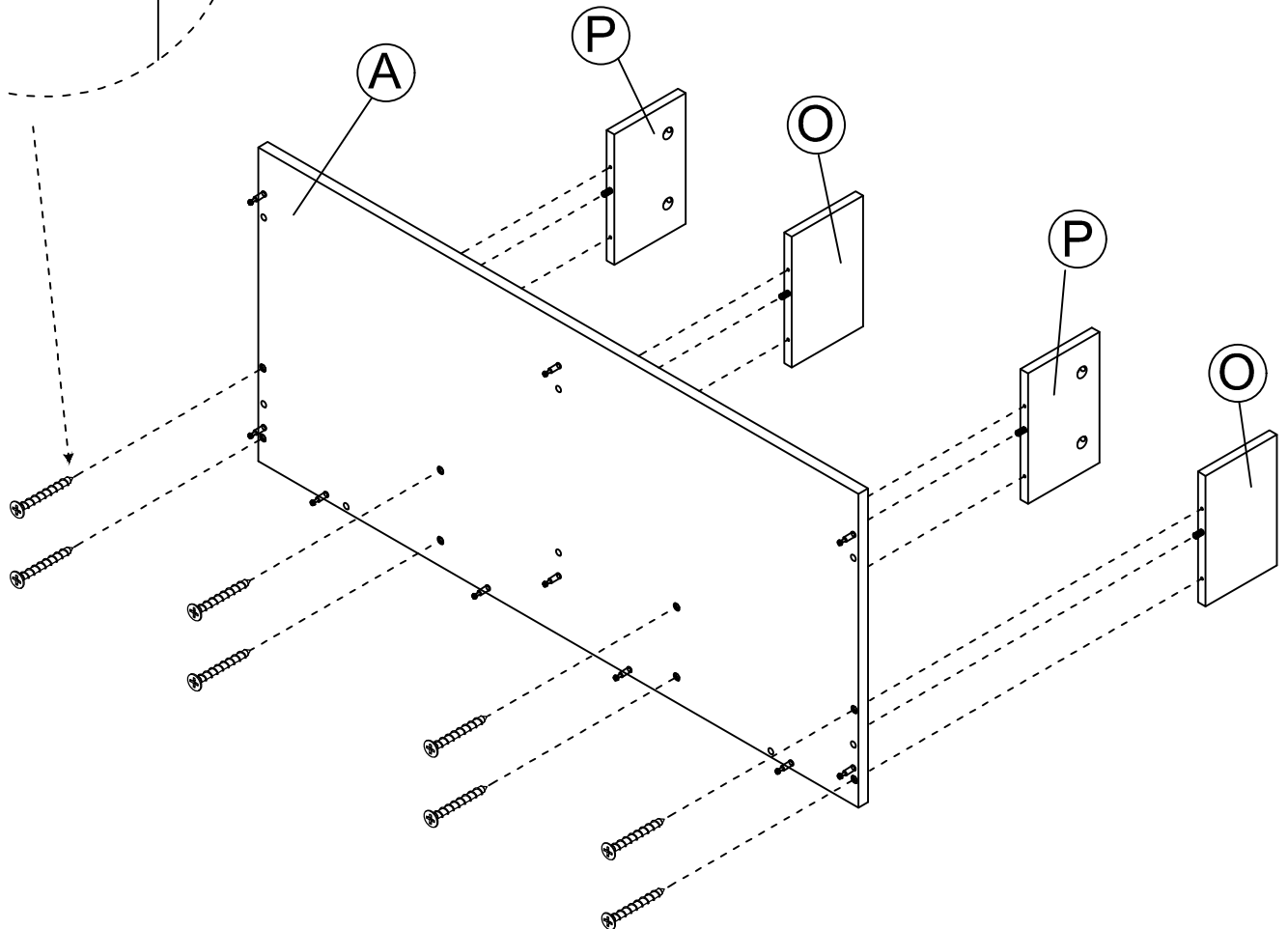
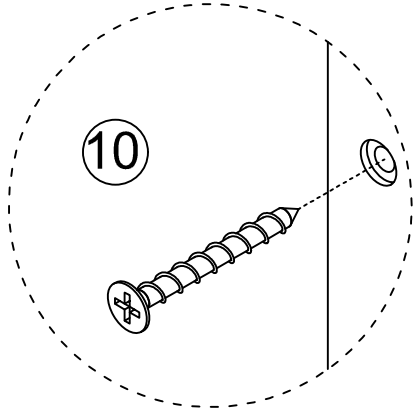
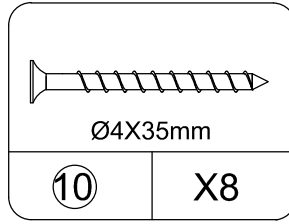
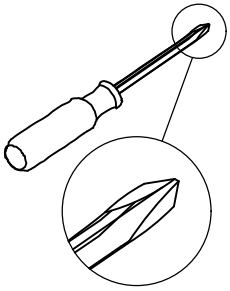

# STEP11

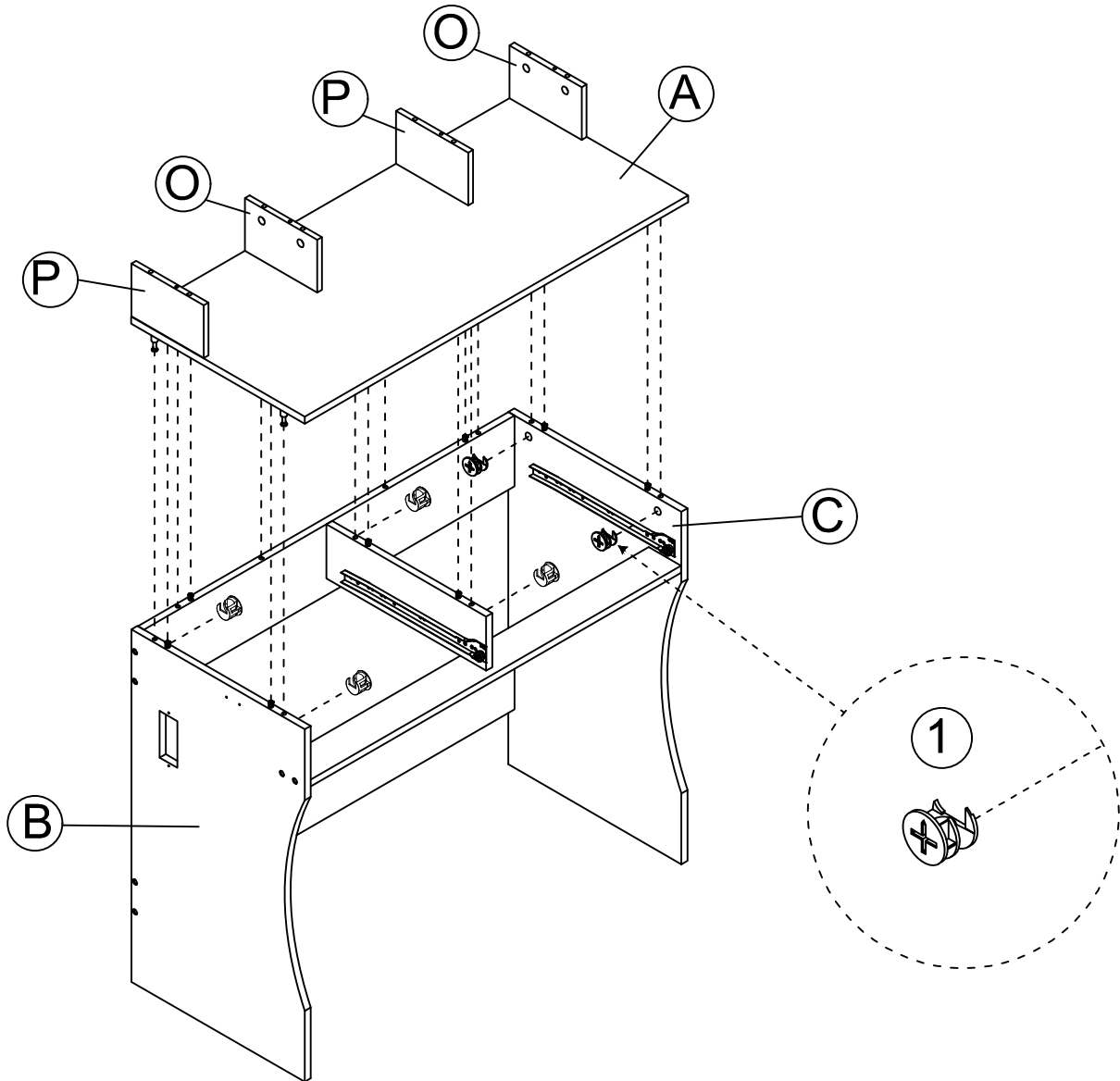
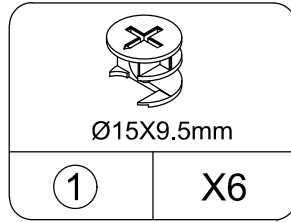
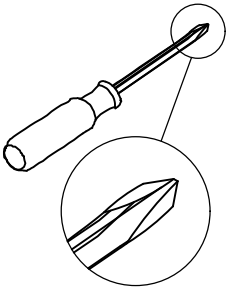

Insert the cam bolt into the hole first, then insert the cam lock and lock it.

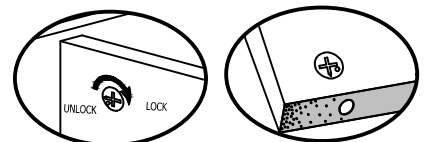

Proper orientation of CAM LOCK



# STEP12

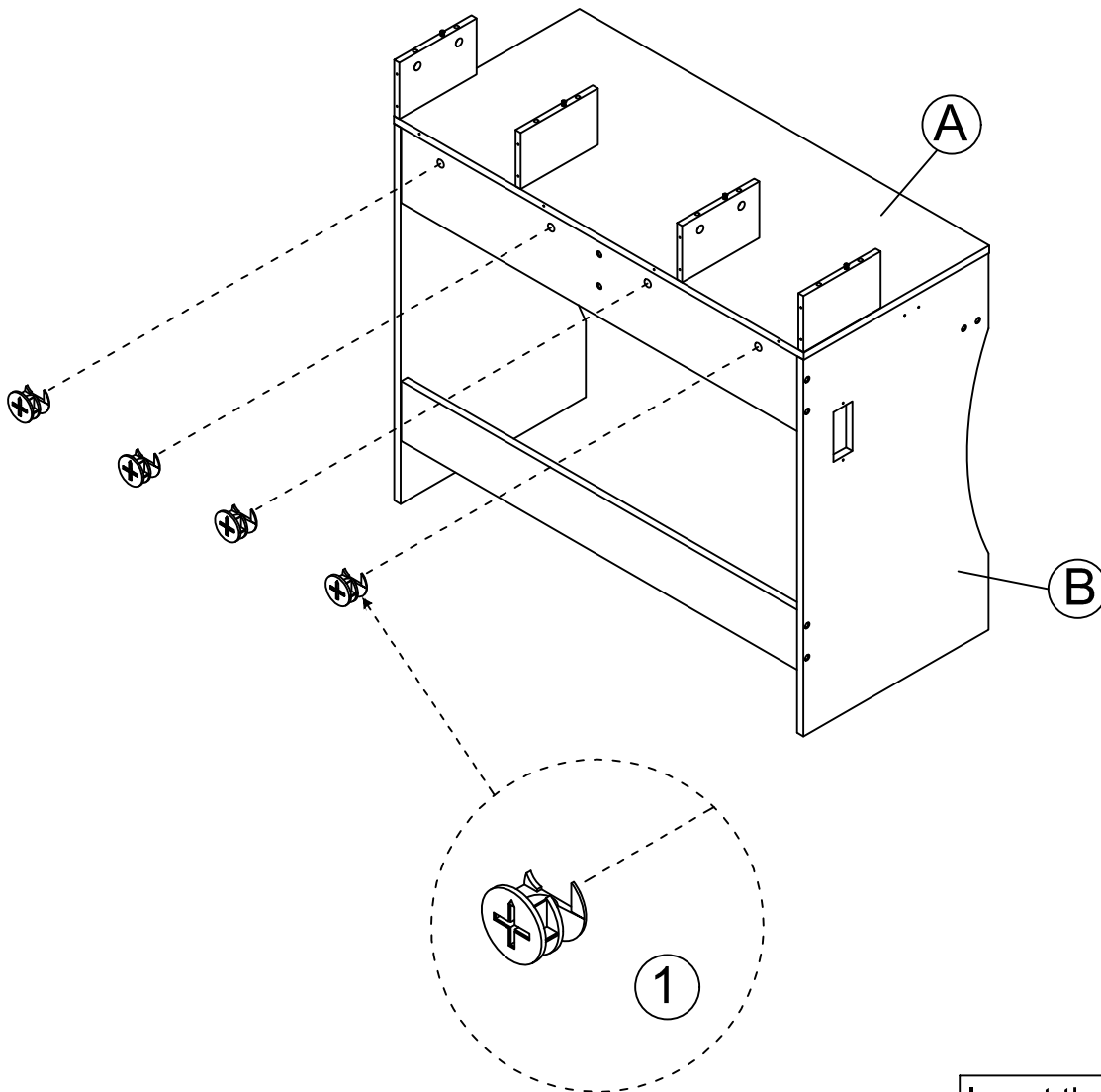
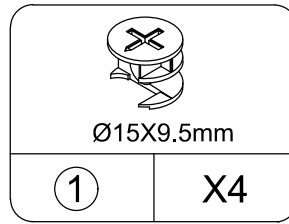
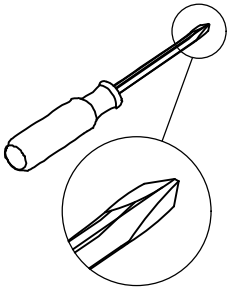

Insert the cam bolt into the hole first, then insert the cam lock and lock it.

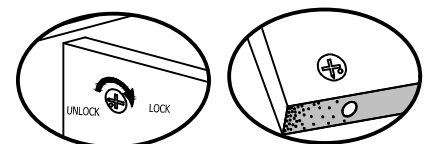

# STEP13

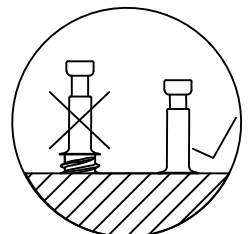
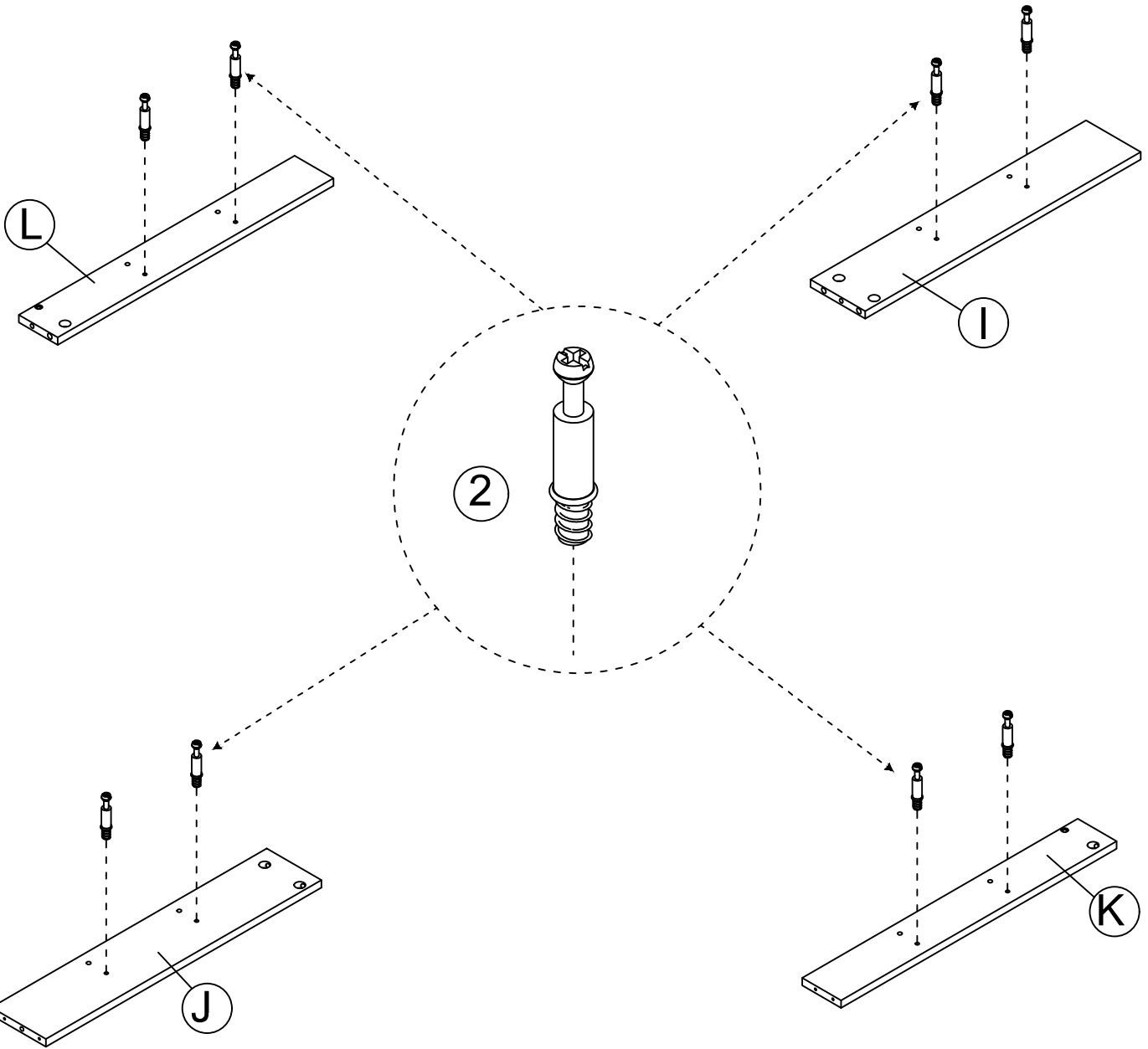
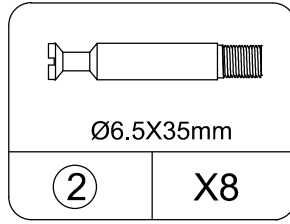
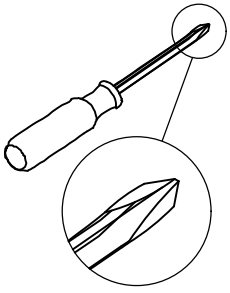

# STEP14

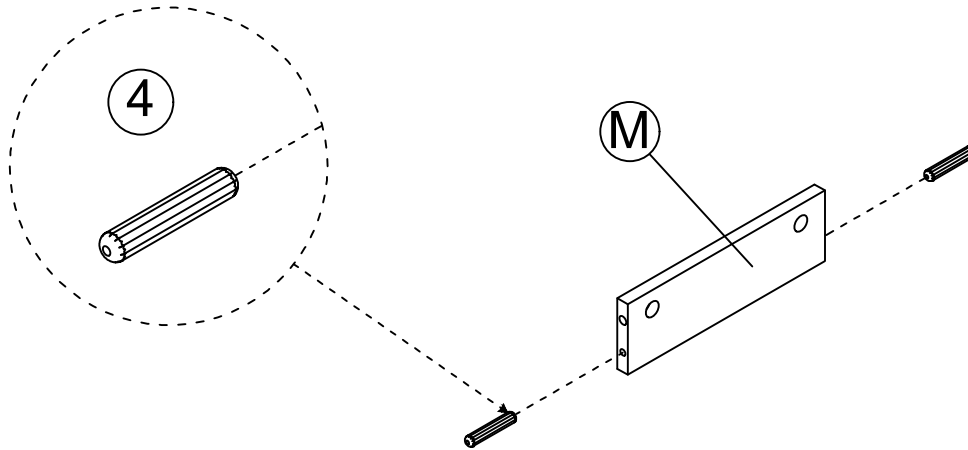
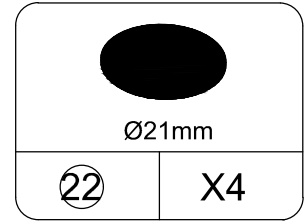
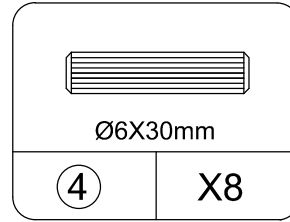
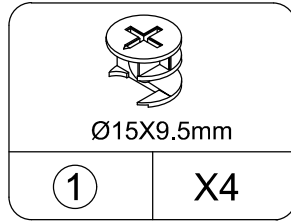
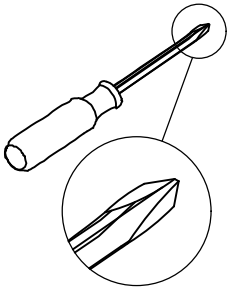

X4

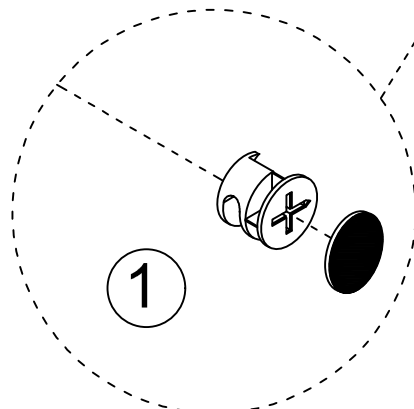
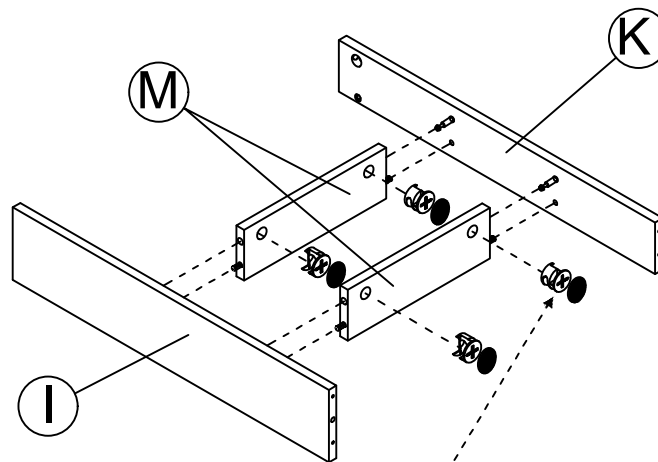

Insert the cam bolt into the hole first, then insert the cam lock and lock it.

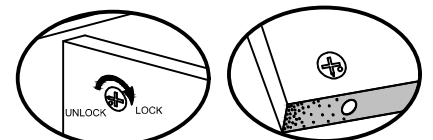

Proper orientation of CAM LOCK

# STEP15

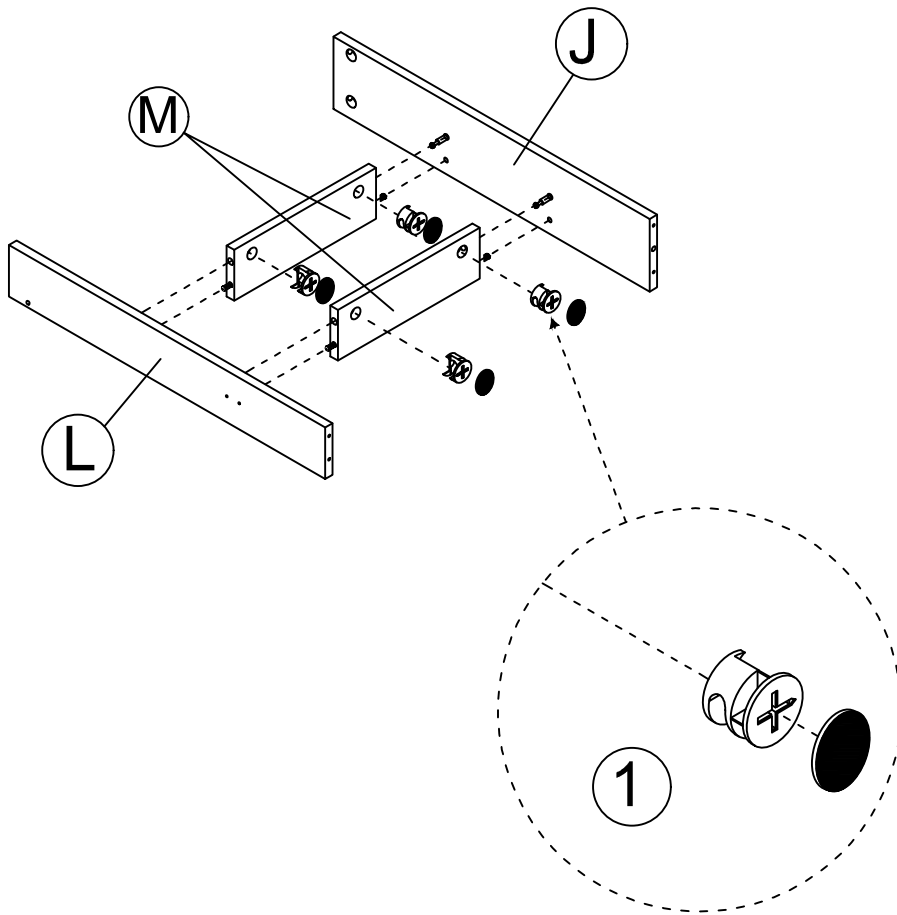
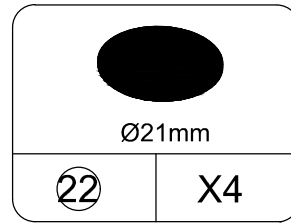
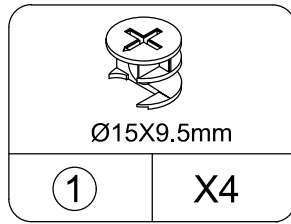
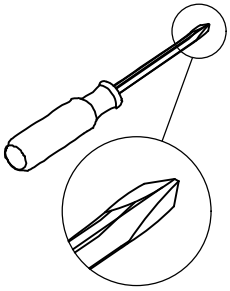

Insert the cam bolt into the hole first, then insert the cam lock and lock it.

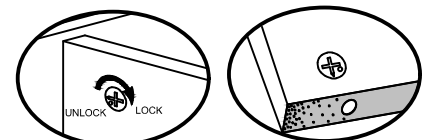

Proper orientation of CAM LOCK

# STEP 16

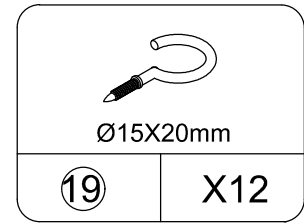
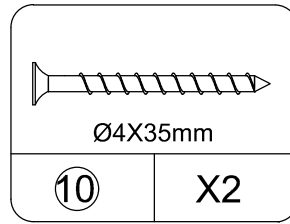
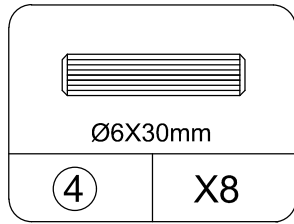
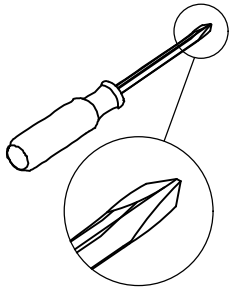

WITHOUT EDGE BANDING

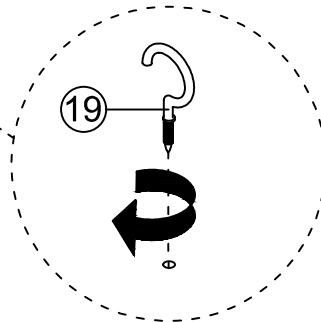
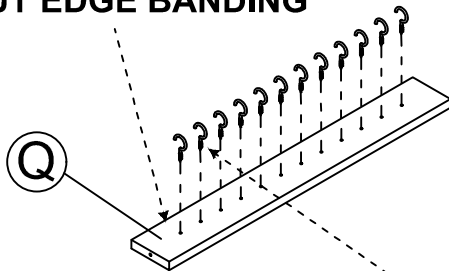

THE RIGHT DIRECTION

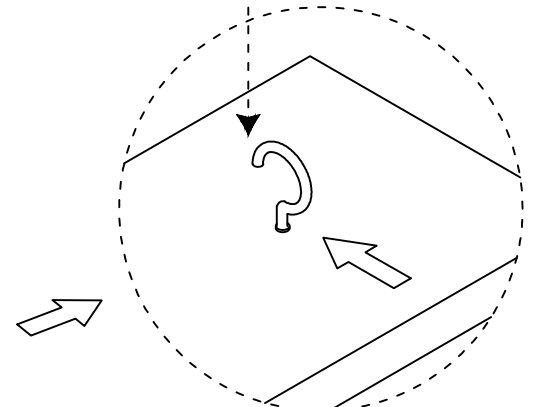

FINISH

No. 24 hardware completion direction

WITHOUT EDGE BANDING

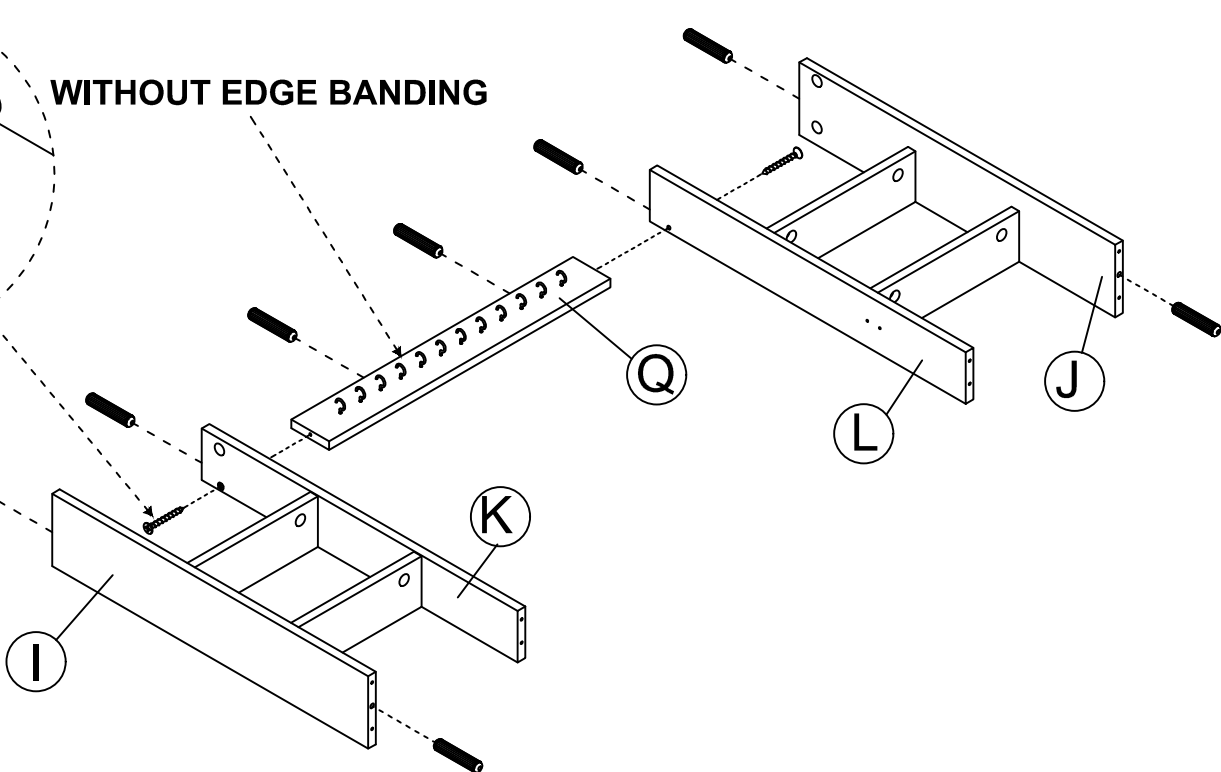
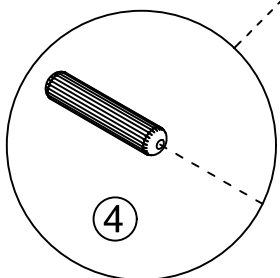
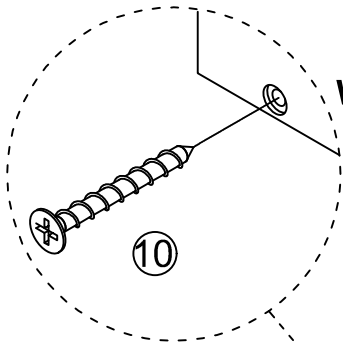

# STEP 17

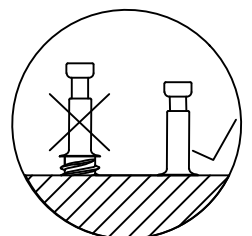
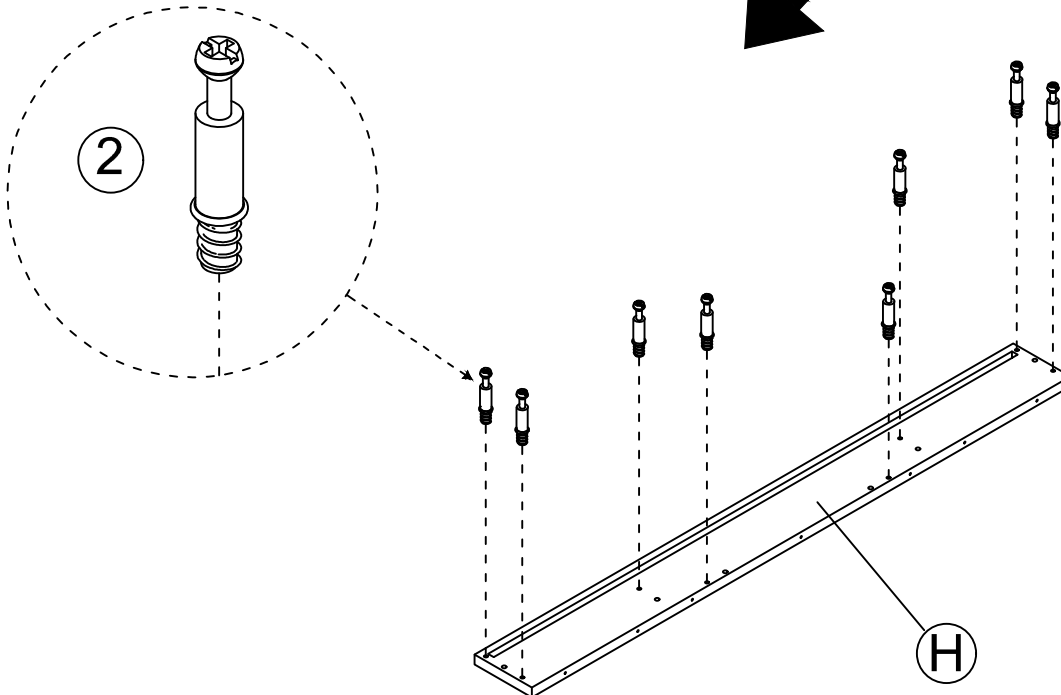
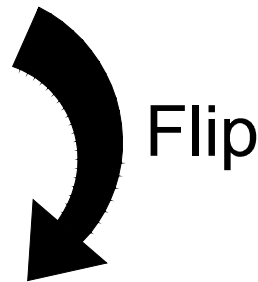
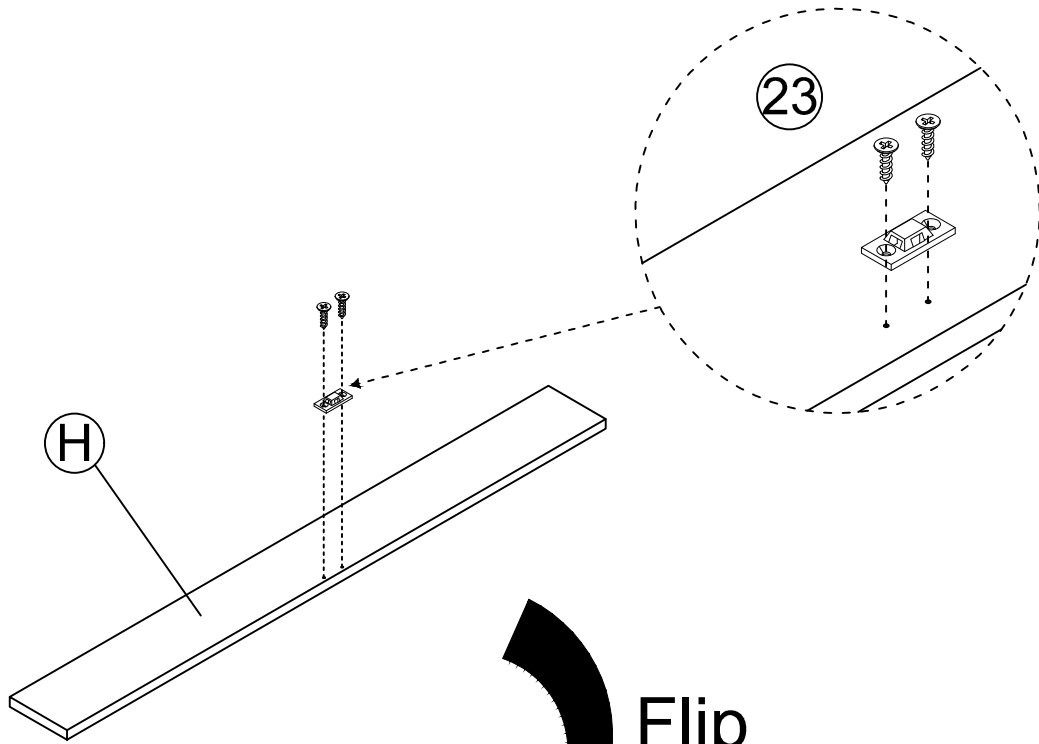
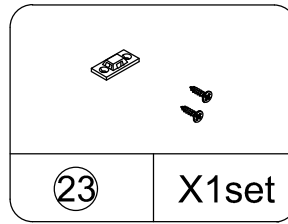
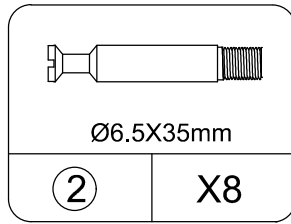
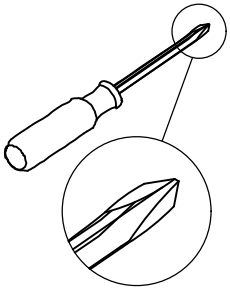

# STEP18

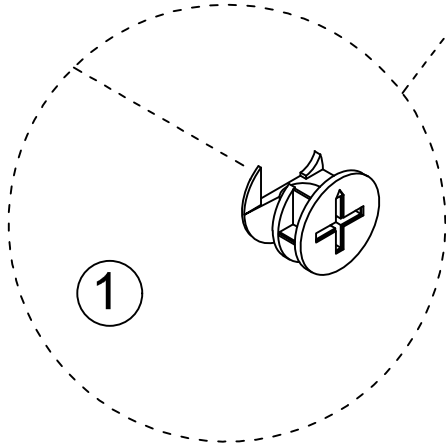
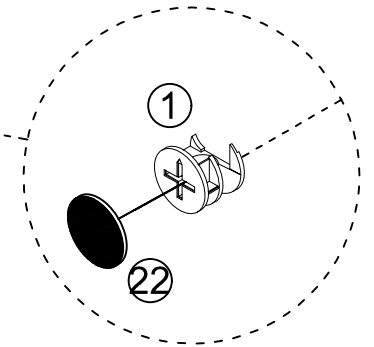
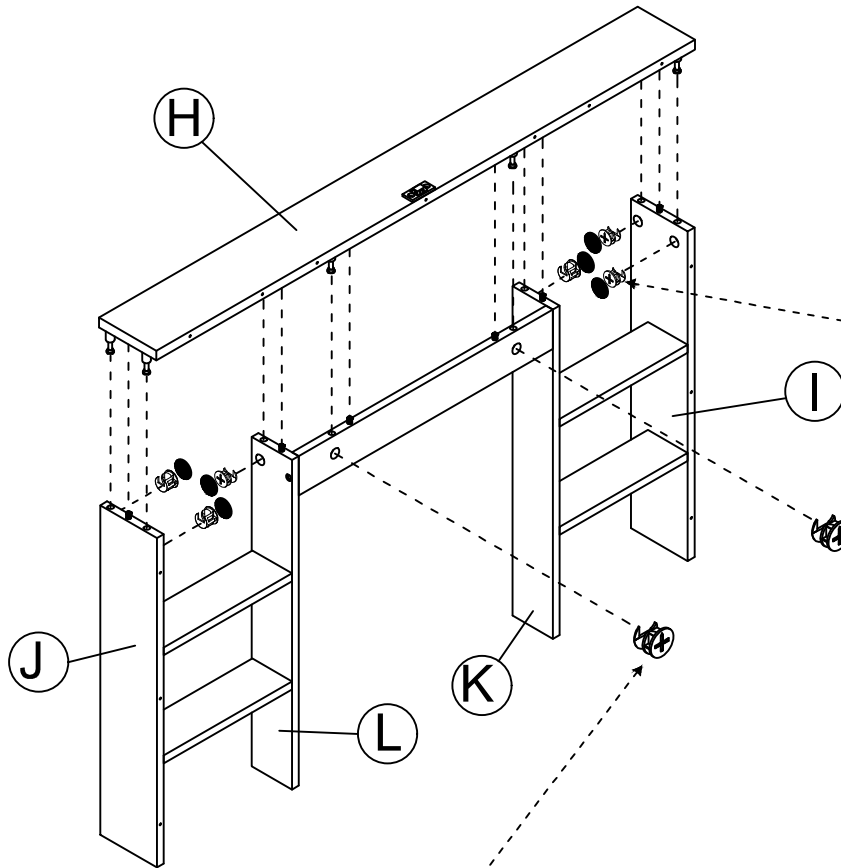
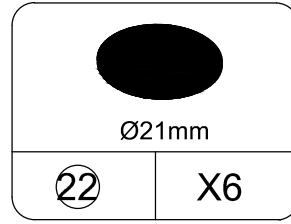
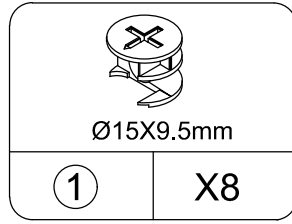
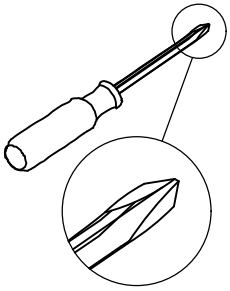

Insert the cam bolt into the hole first, then insert the cam lock and lock it.

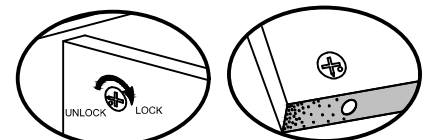

Proper orientation of CAM LOCK

# STEP19

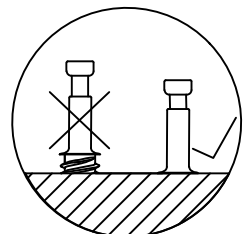
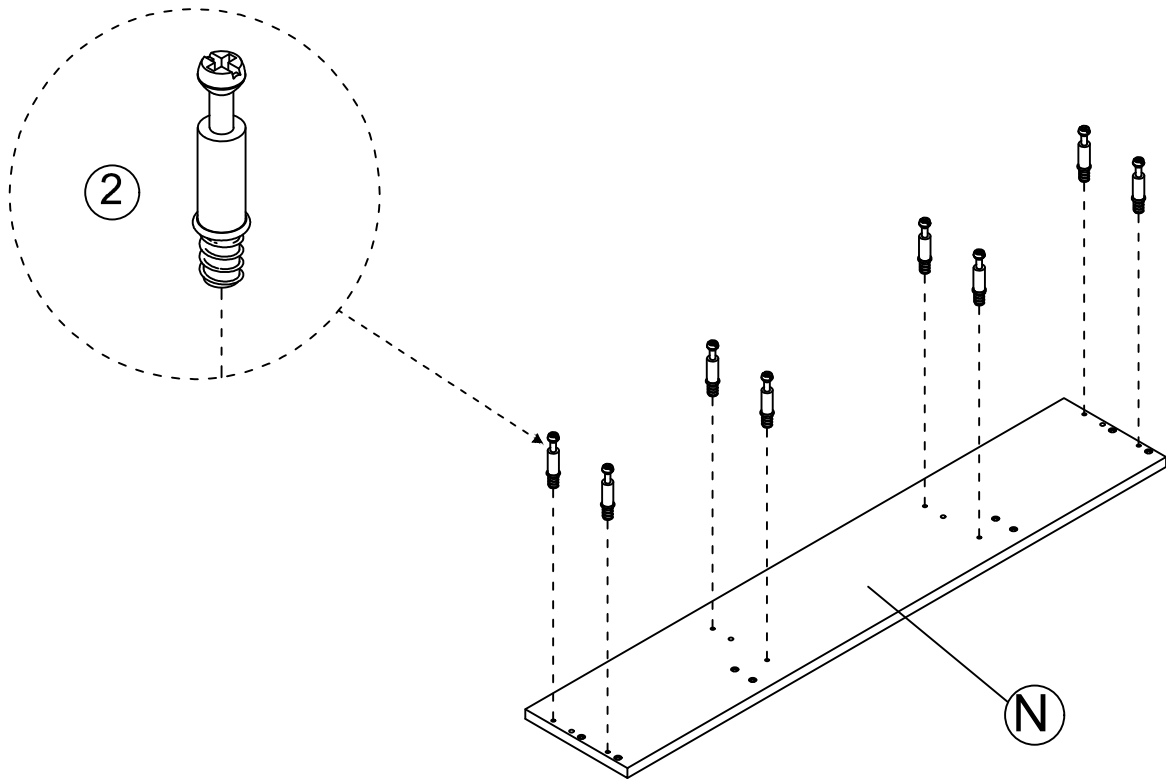
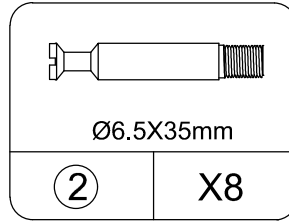
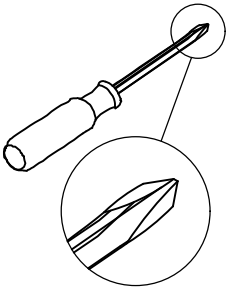



# STEP20

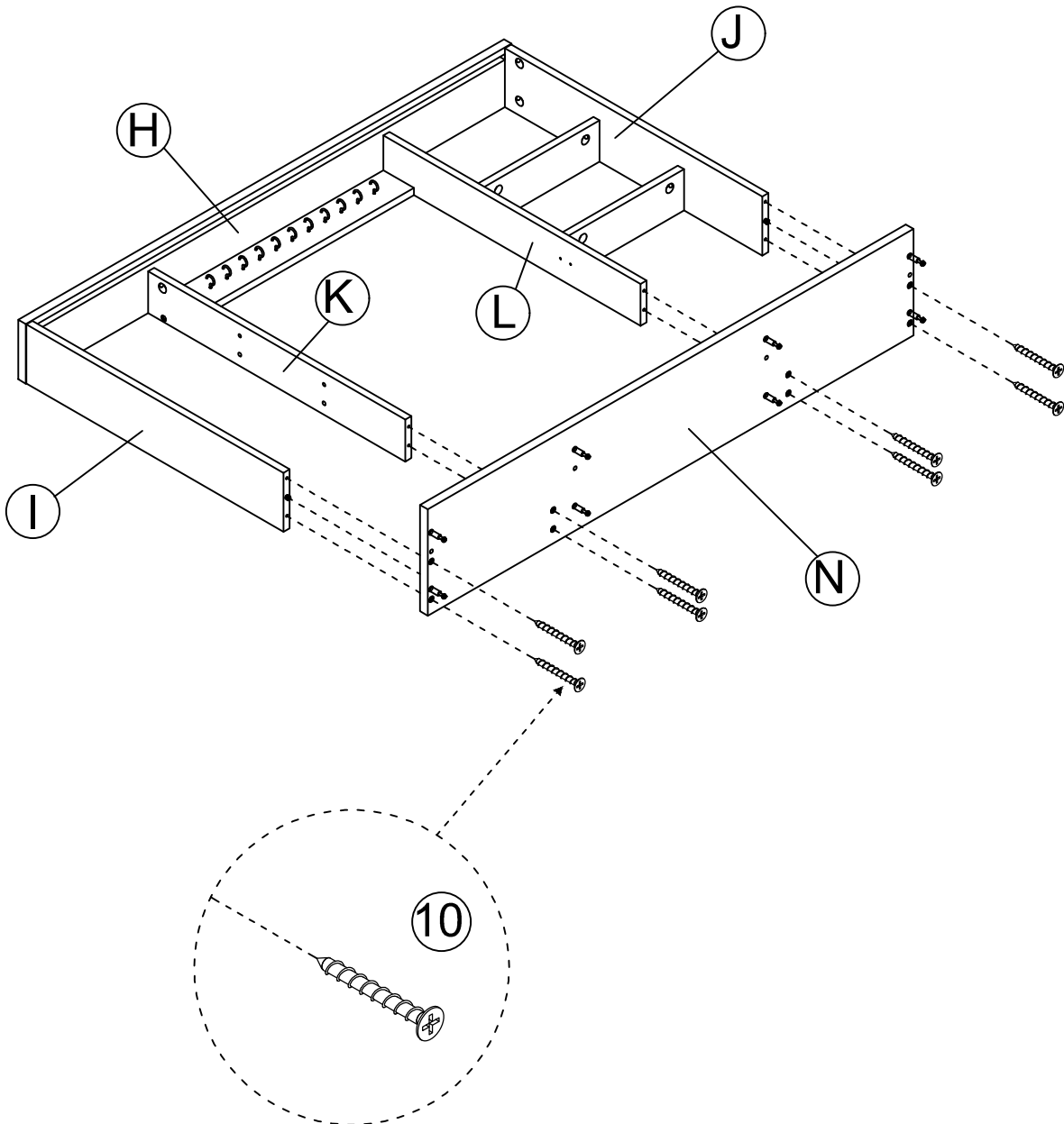
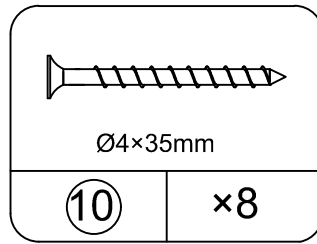
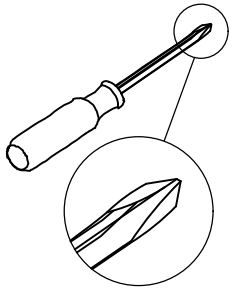

# STEP 21

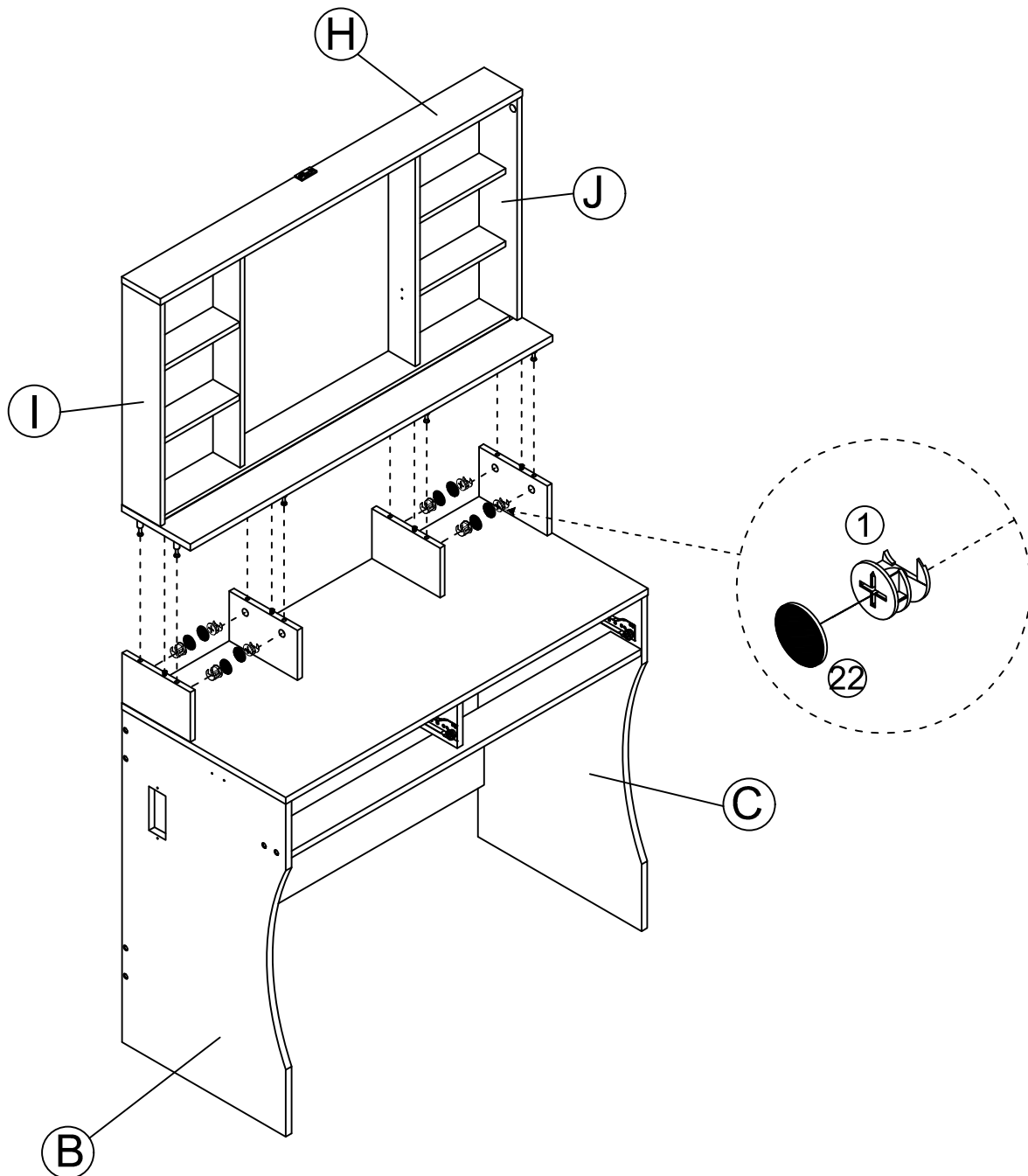
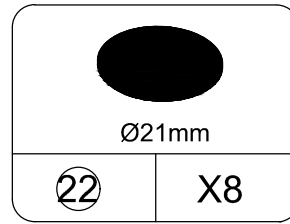
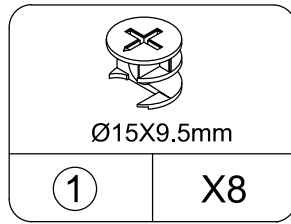
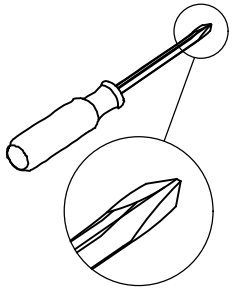

# STEP22

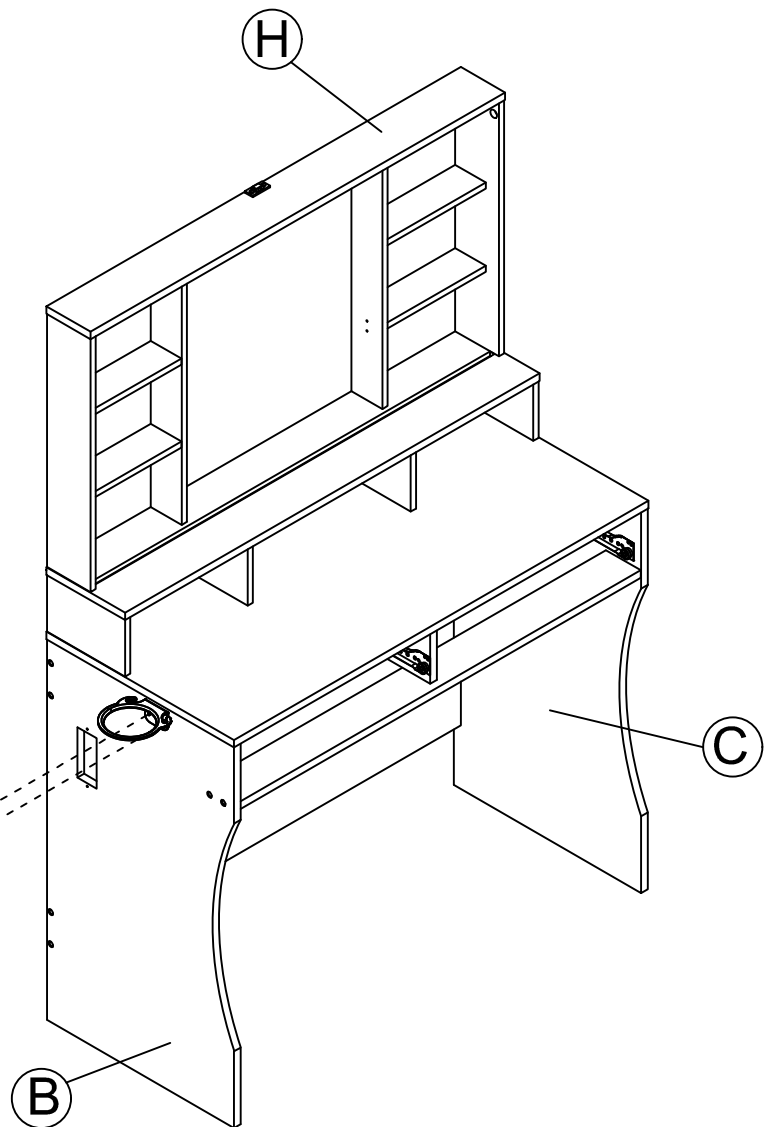
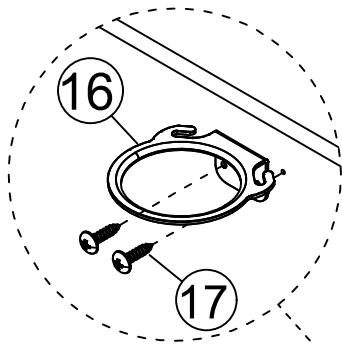
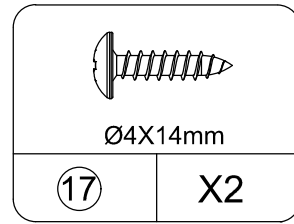
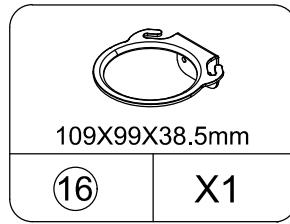
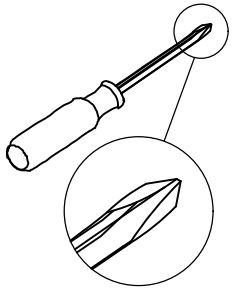

# STEP23

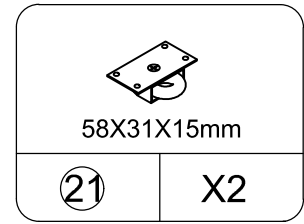
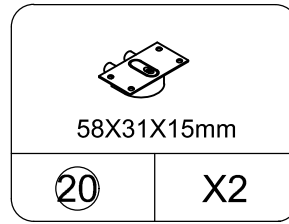
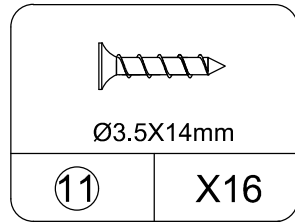
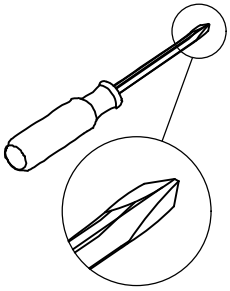

Put the base of the pulley into the groove of the upper frame of the mirror and lock it with screws.

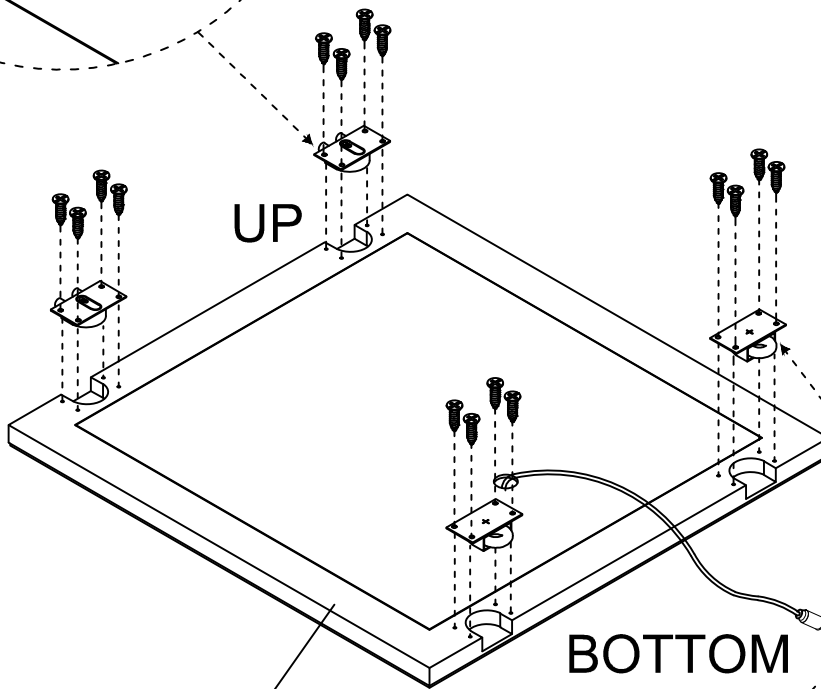
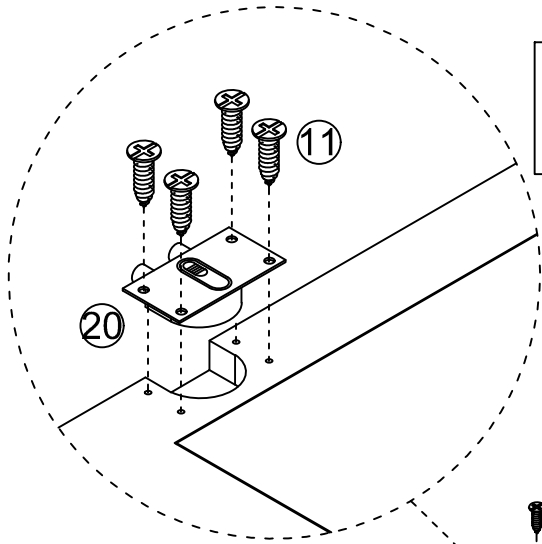

Put the base of the pulley into the groove of the bottom frame of the mirror and lock it with screws.

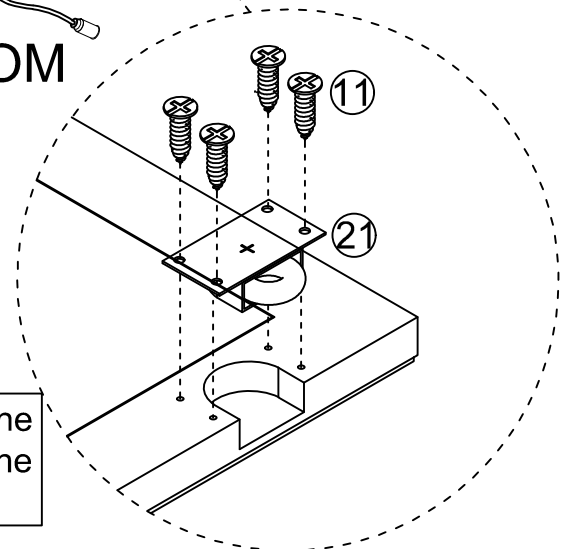

# STEP24

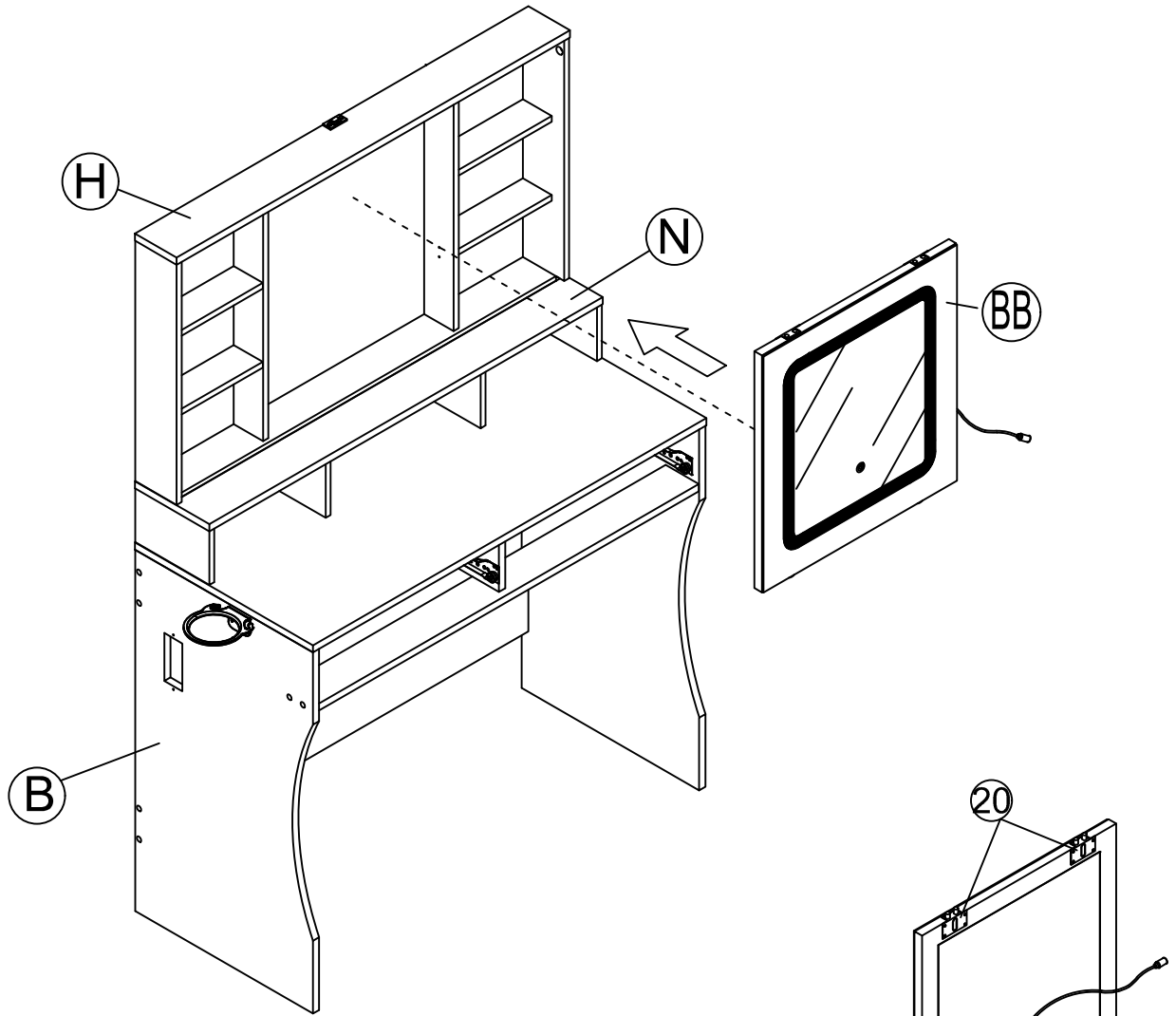
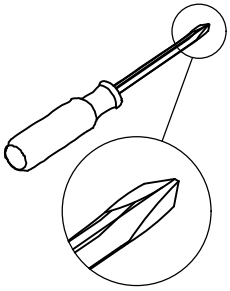

## Installation instructions:

- A: Press the button on the accessory 20# ,as shown in ①
- B: Align the wheels on the fitting 21# to the N plate groove,as shown in ②
- C: Then align the button on the fitting 20# to the slot on the H board and turn the button on

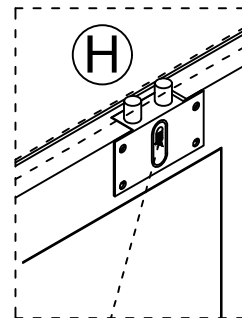
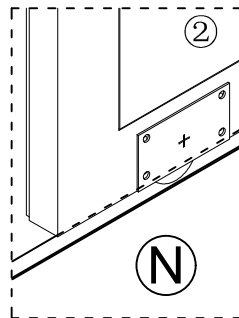
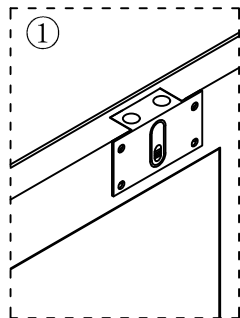
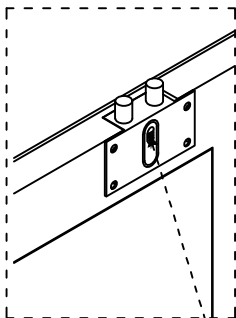

Push it and  
slide down

Put It in the rail slot,  
and hold it up

# STEP 25

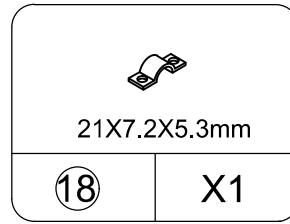
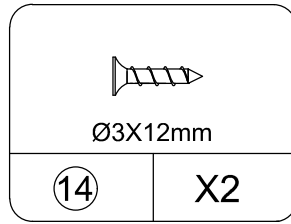
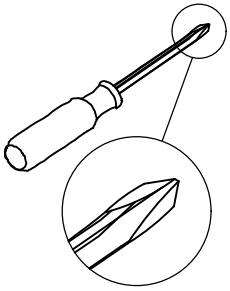

The length of the line from the point where it comes out of the hole to the point where it is fixed by the presser is 460mm.

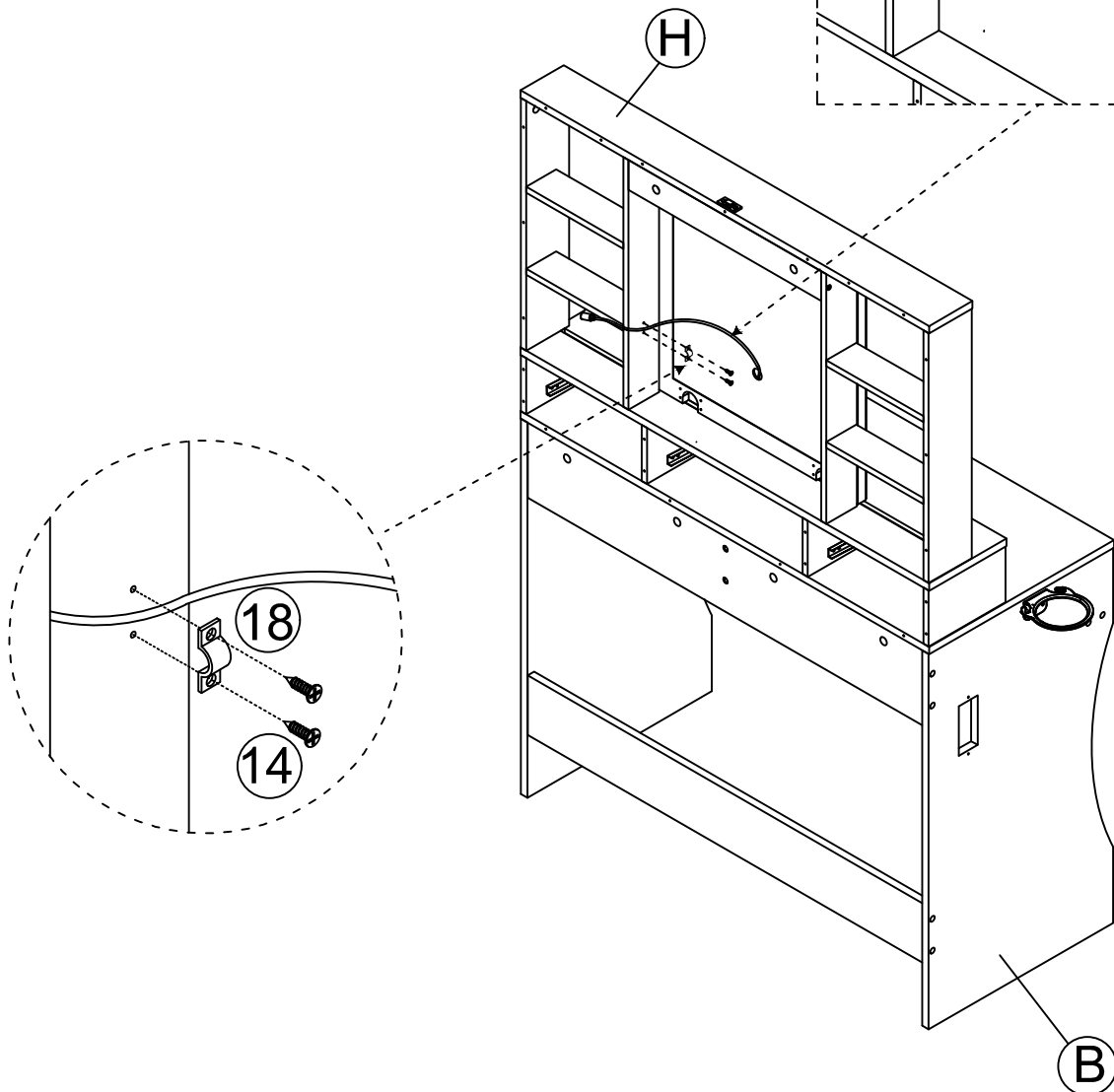
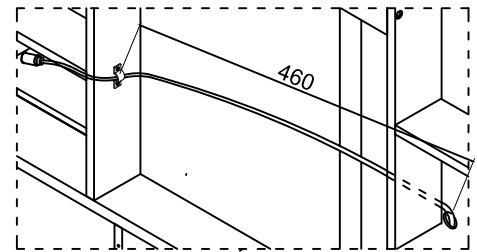

# STEP 26

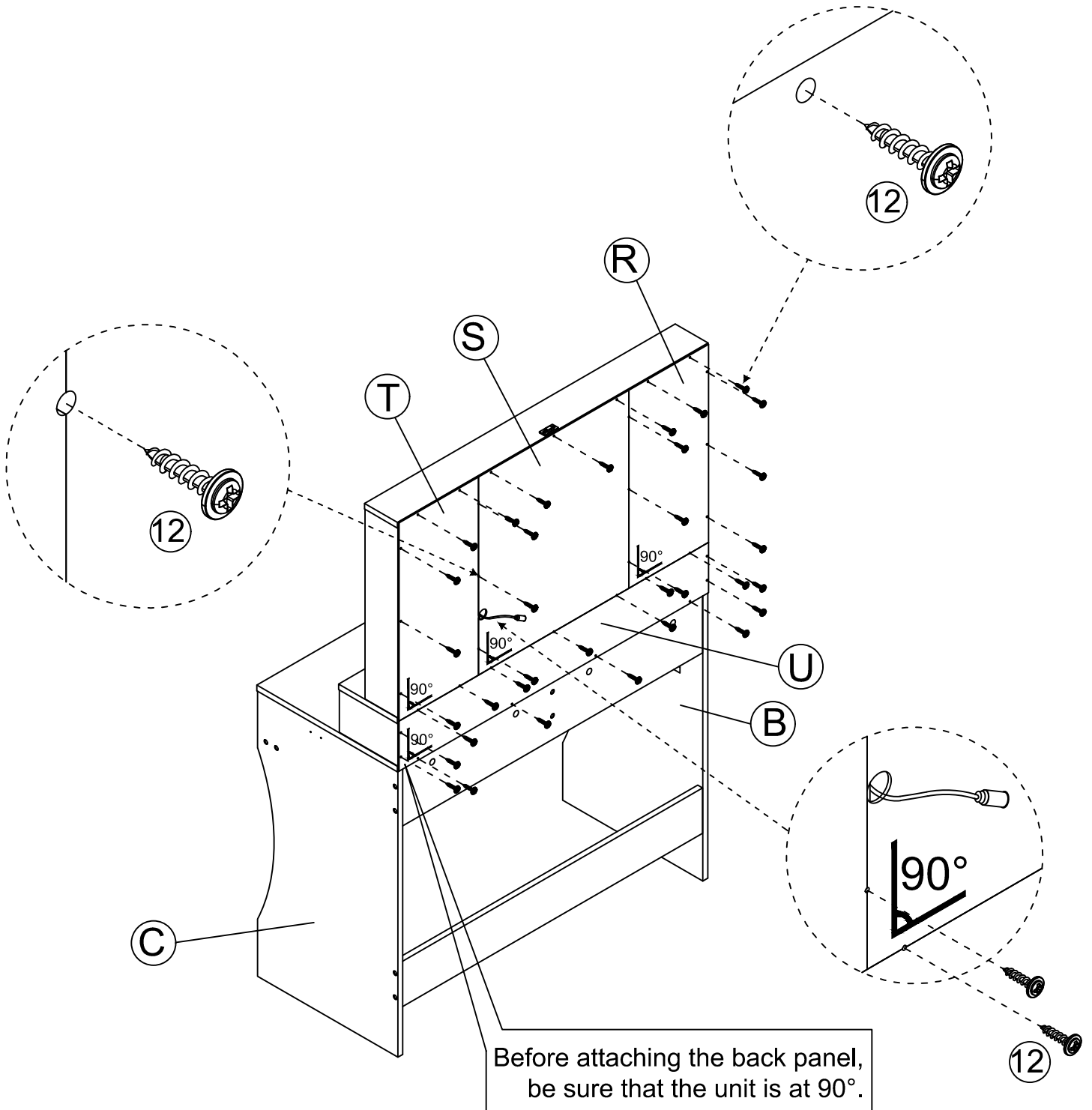
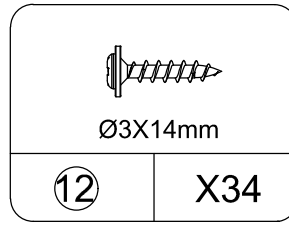
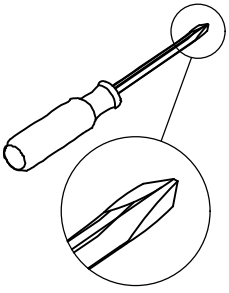

# STEP27

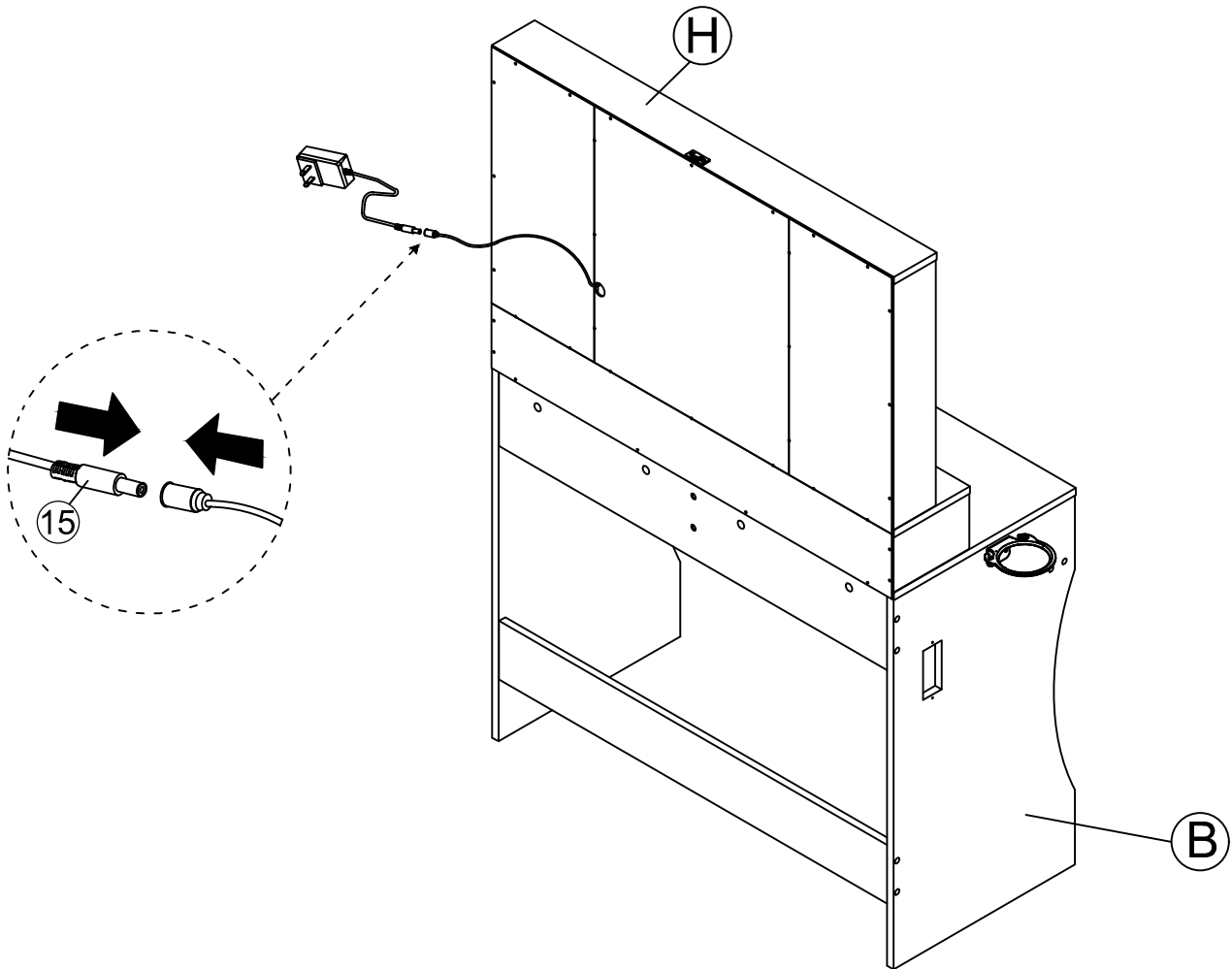
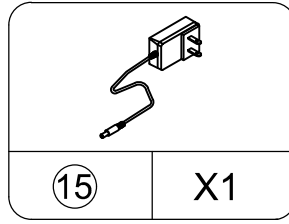
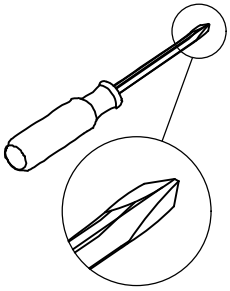

When making up can use the switch to turn on or off the light. the dressing table brings you 3temperature light modes, touch the button you can easy light up the mirror and changeet your different needs, long press to adjust the brightness



# STEP28

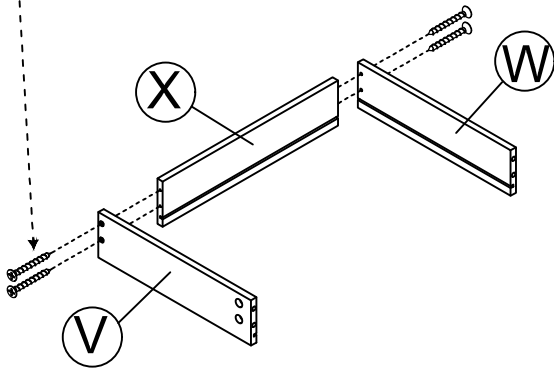
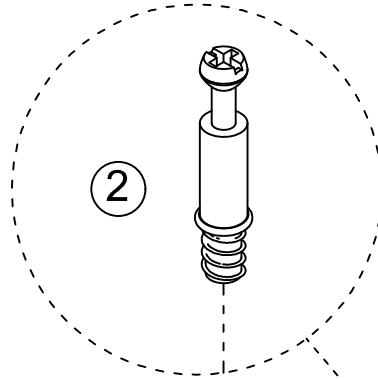
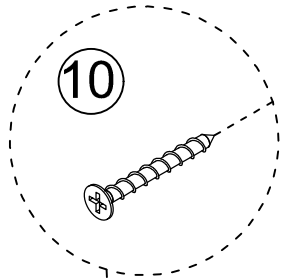
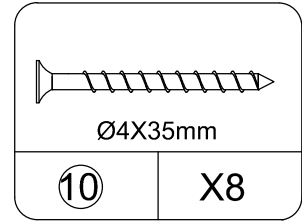
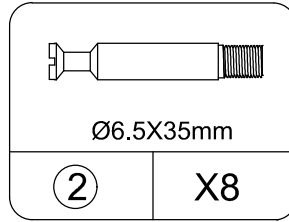
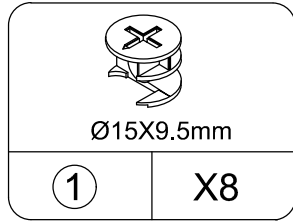
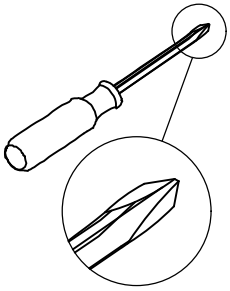

Step 1

Step3

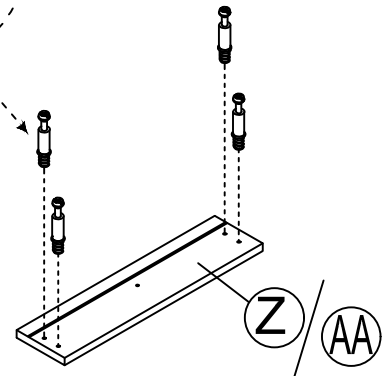

Step 2

Step4

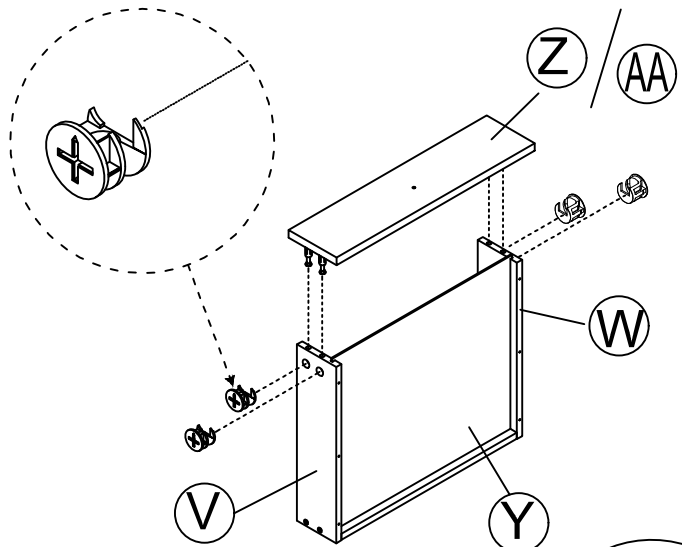
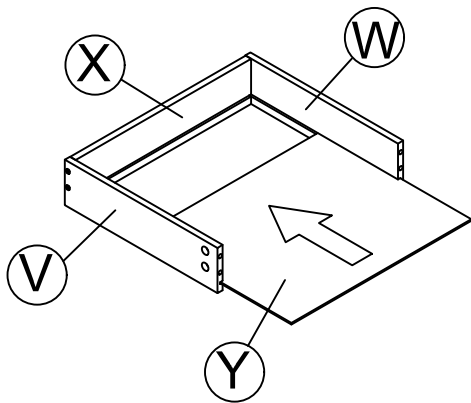

Insert the cam bolt into the hole first, then insert the cam lock and lock it.

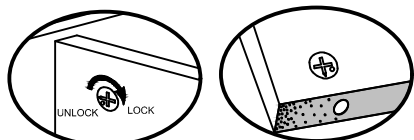

Proper orientation of CAM LOCK

# X2

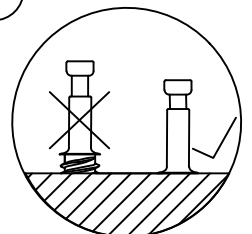

# STEP29

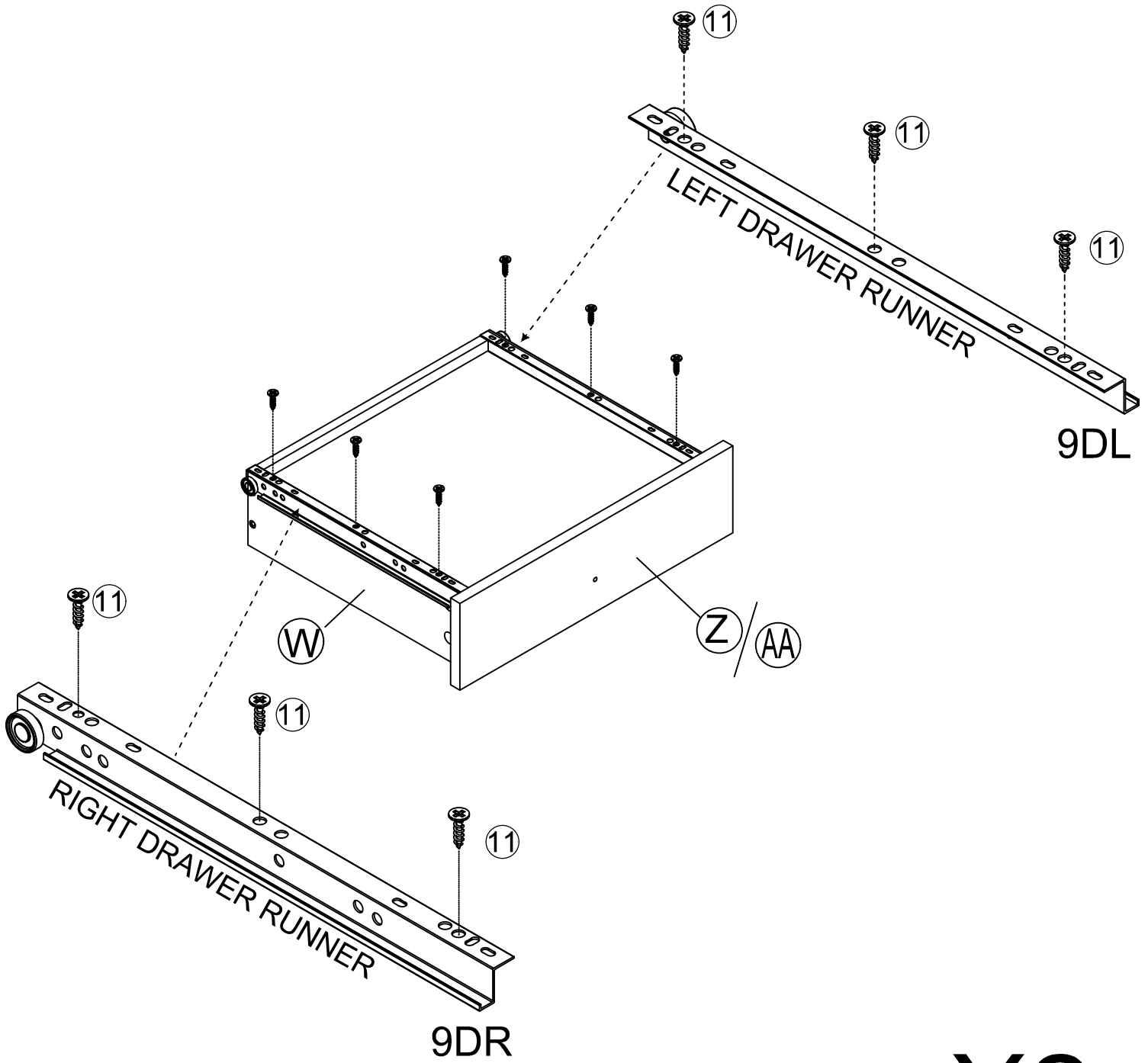
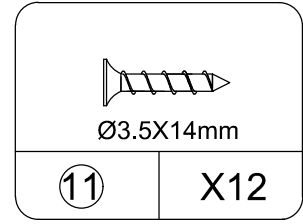
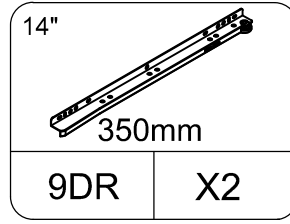
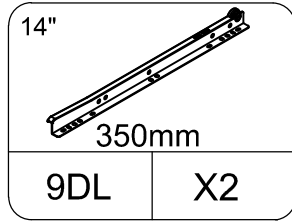
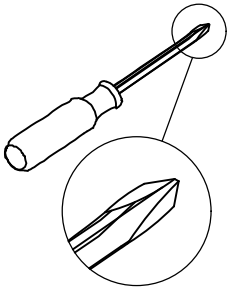

# X2

# STEP30

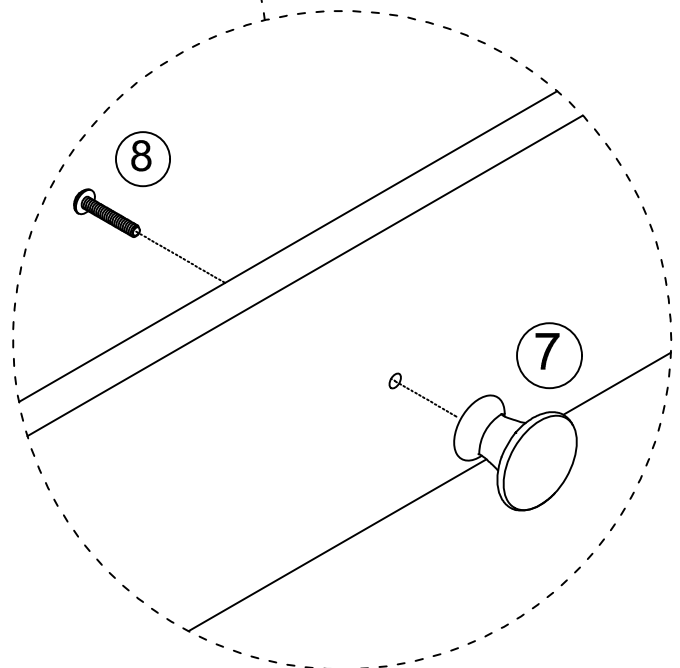
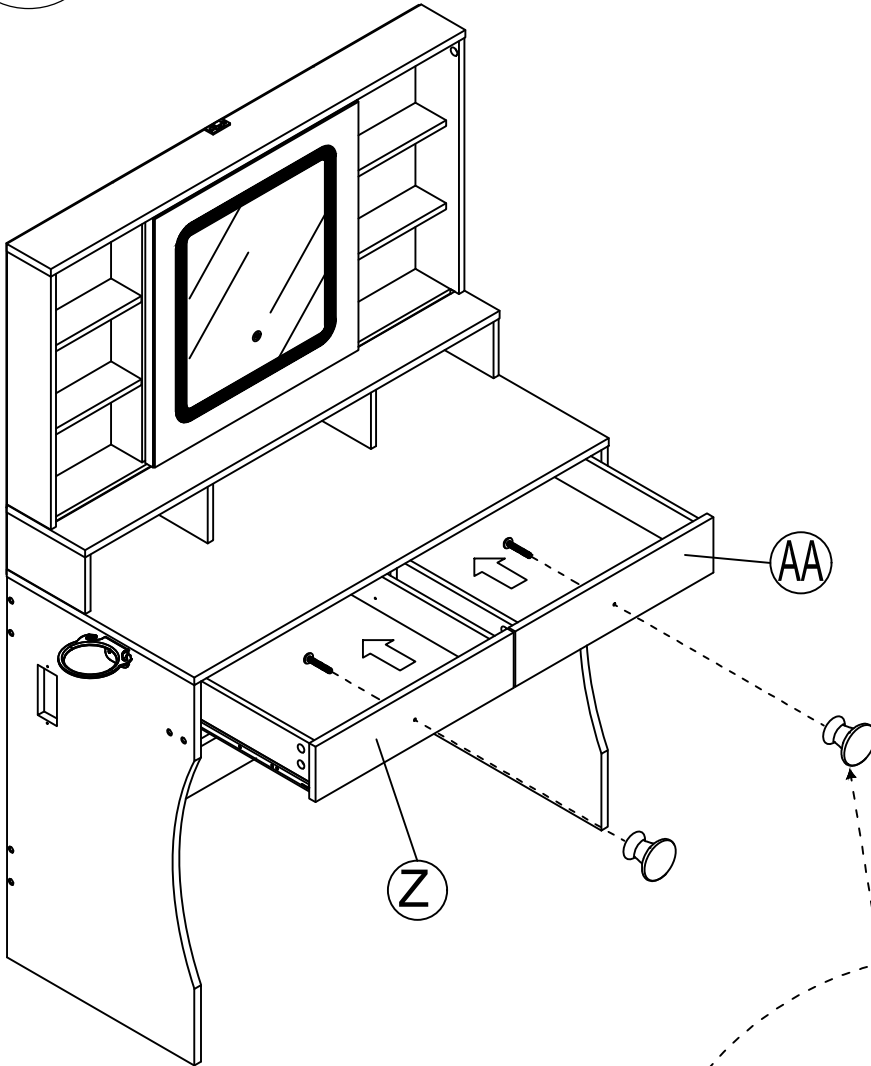
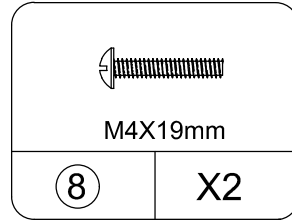
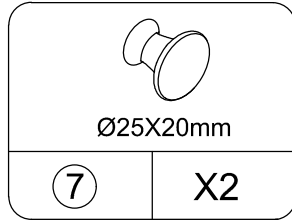
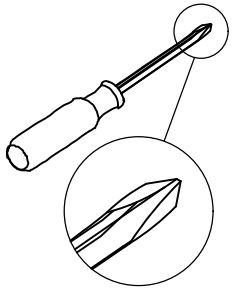

# STEP31

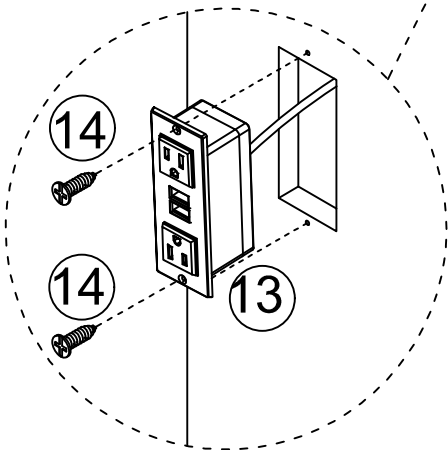
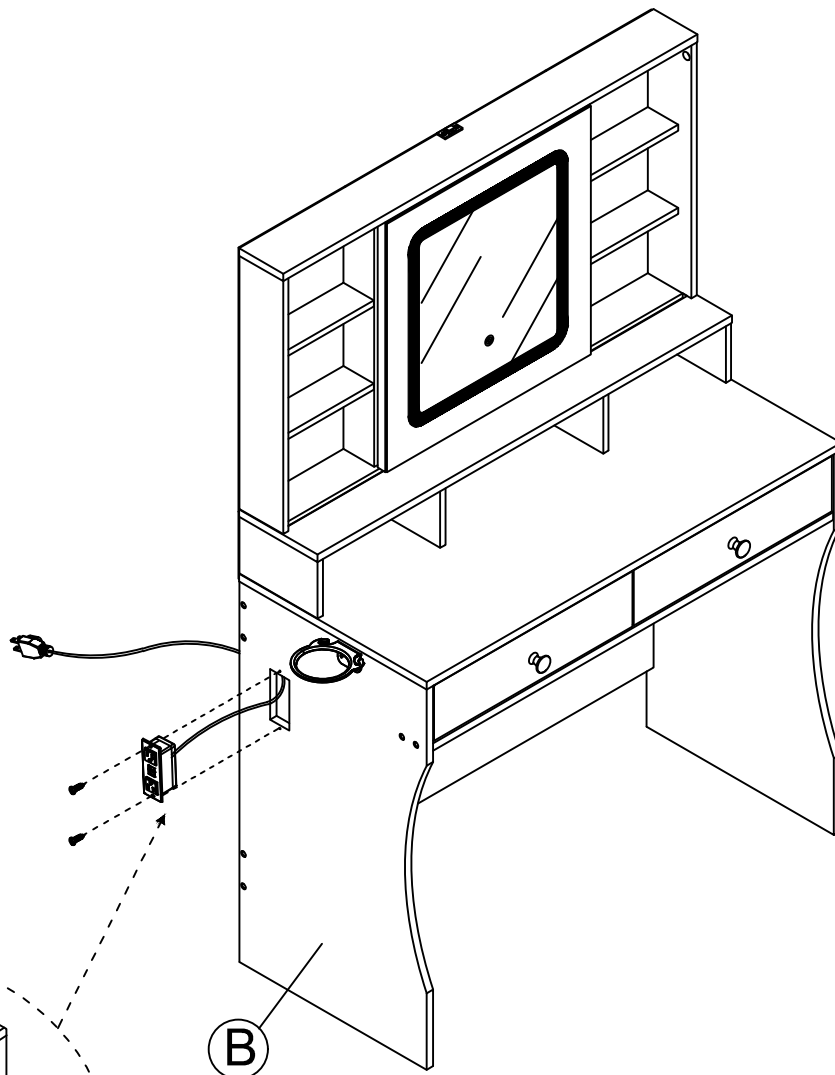
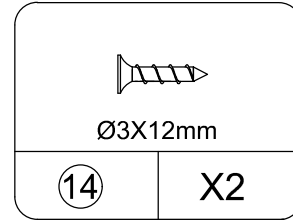
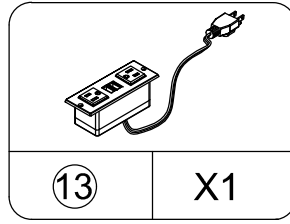
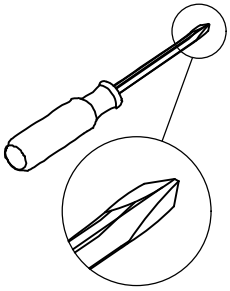

# STEP32

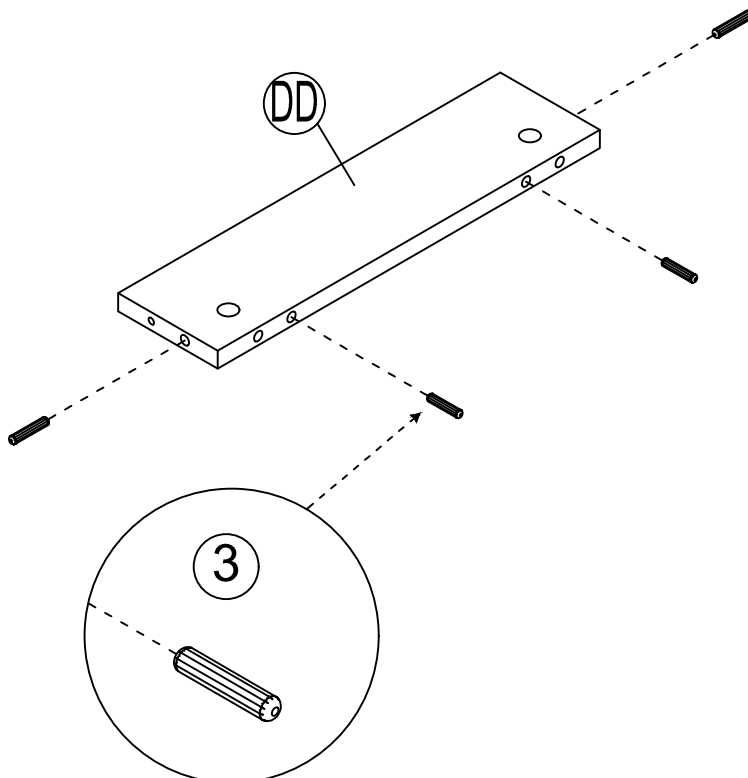
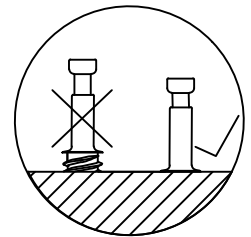
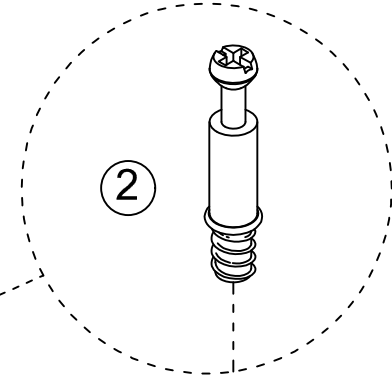
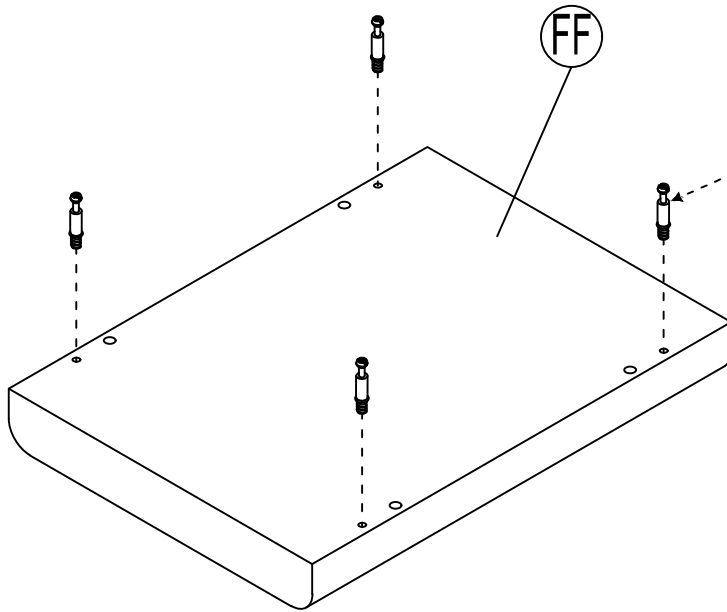
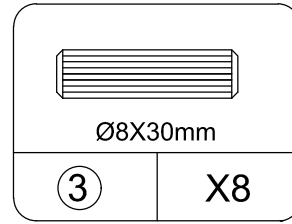
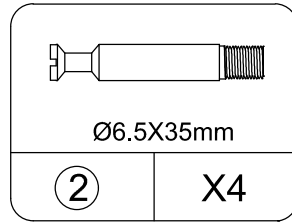
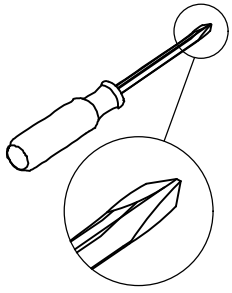

**X2**

# STEP33

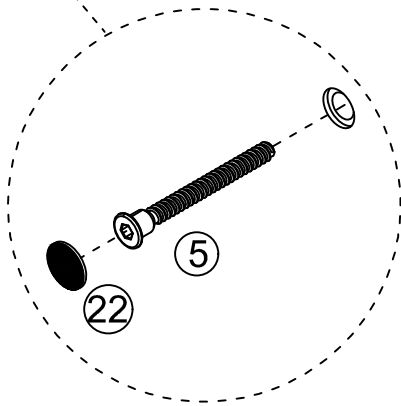
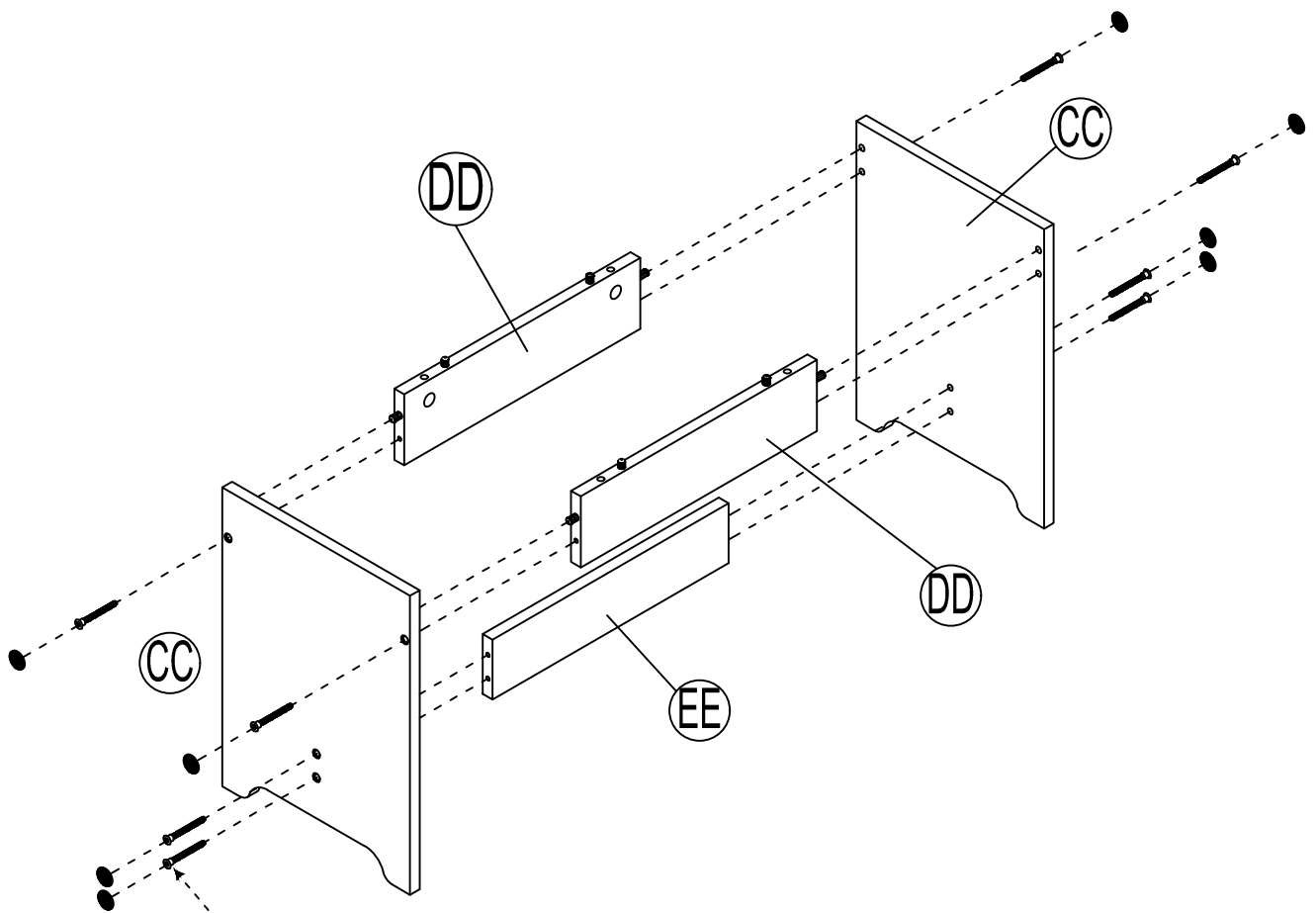
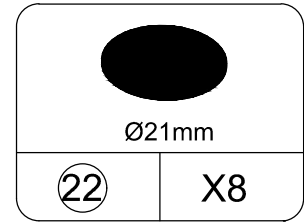
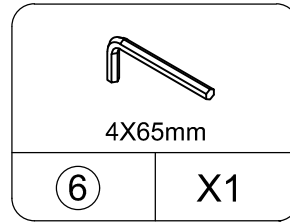
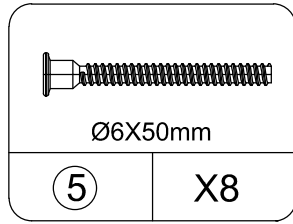
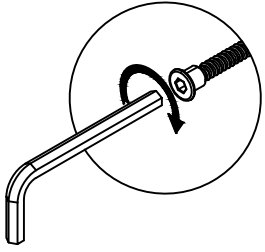

# STEP34

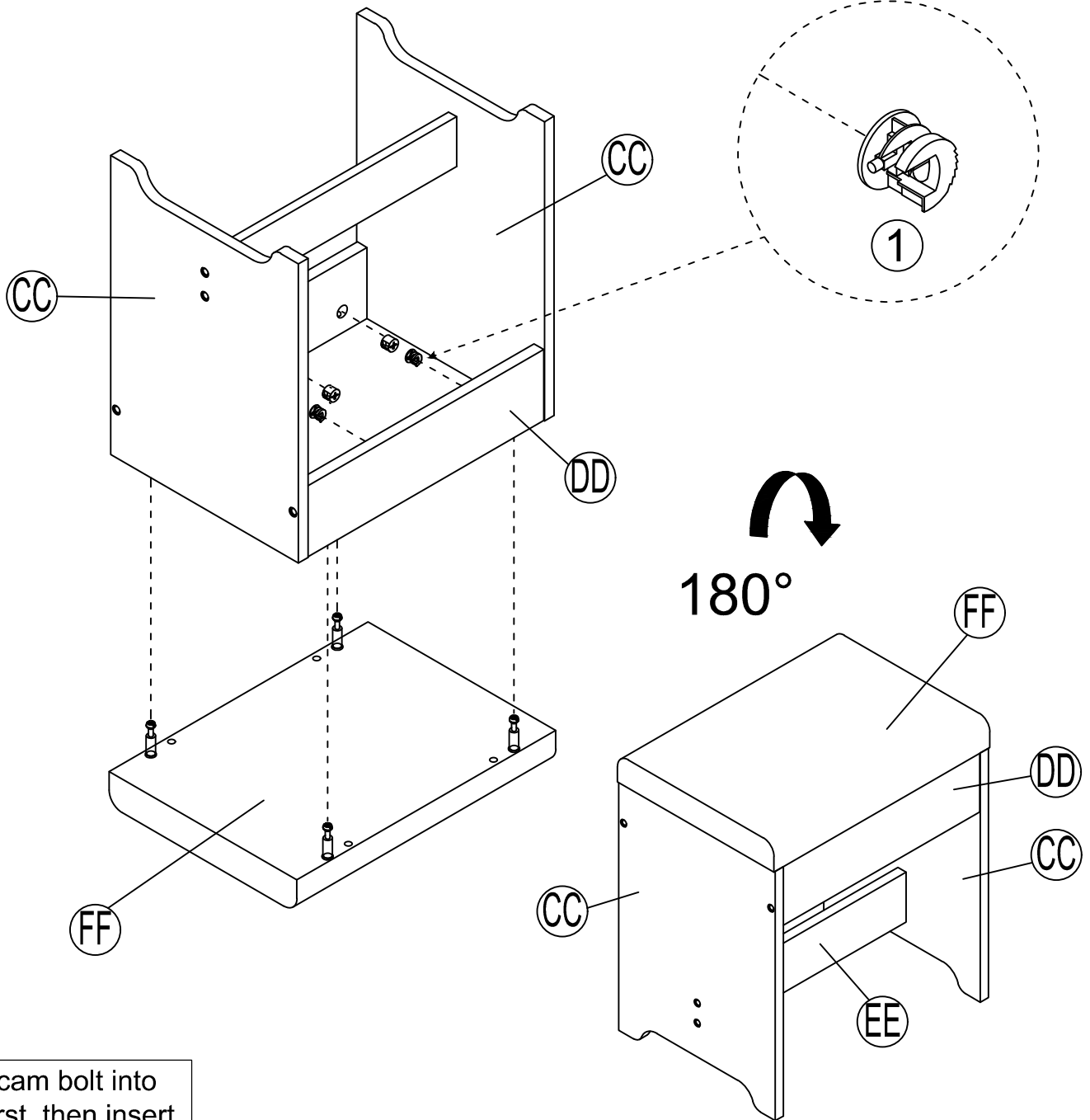
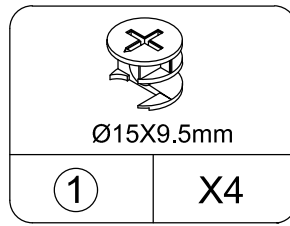
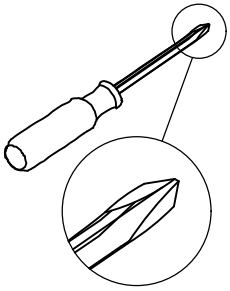

Insert the cam bolt into the hole first, then insert the cam lock and lock it.

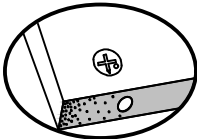

Proper orientation of CAM LOCK

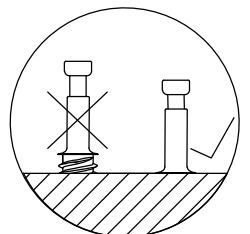

# STEP35

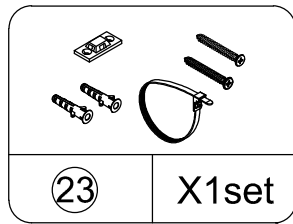
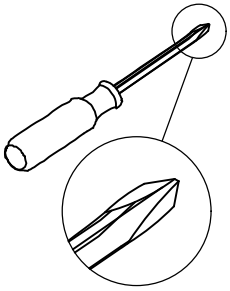

**NOTE:** The tipping restraint hardware included is for wooden stud wall construction. It must be attached to a wall stud. Depending upon your wall construction different anchor hardware may be required. Please contact your local hardware store for assistance. Young children can be seriously injured by tipping furniture. You must install the tipping restraint hardware with the unit to prevent the unit from tipping, causing any accidents or damage. The tipping restraints are intended only as a deterrent and are not a substitute for proper adult supervision. The tipping restraints are not earthquake restraints. If you wish to add the extra security of earthquake restraints, they must be purchased and installed separately.



## Install the tipping restraint hardware

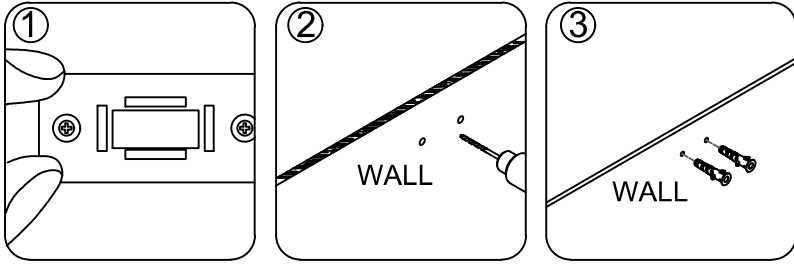

- 1. make mark on the wall
- 2. drill two Ø6 holes on the wall
- 3. put two anchors in the holes

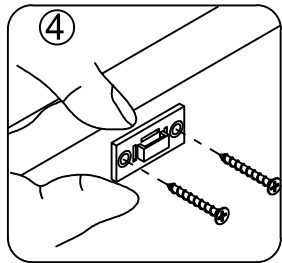

- 4. fix the device on the wall by the long screws

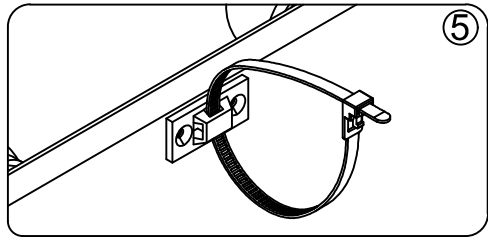

- 5. Push the cabinet close to the wall so that the two bases are close to each other, and then put on nylon tie to tighten it.

