

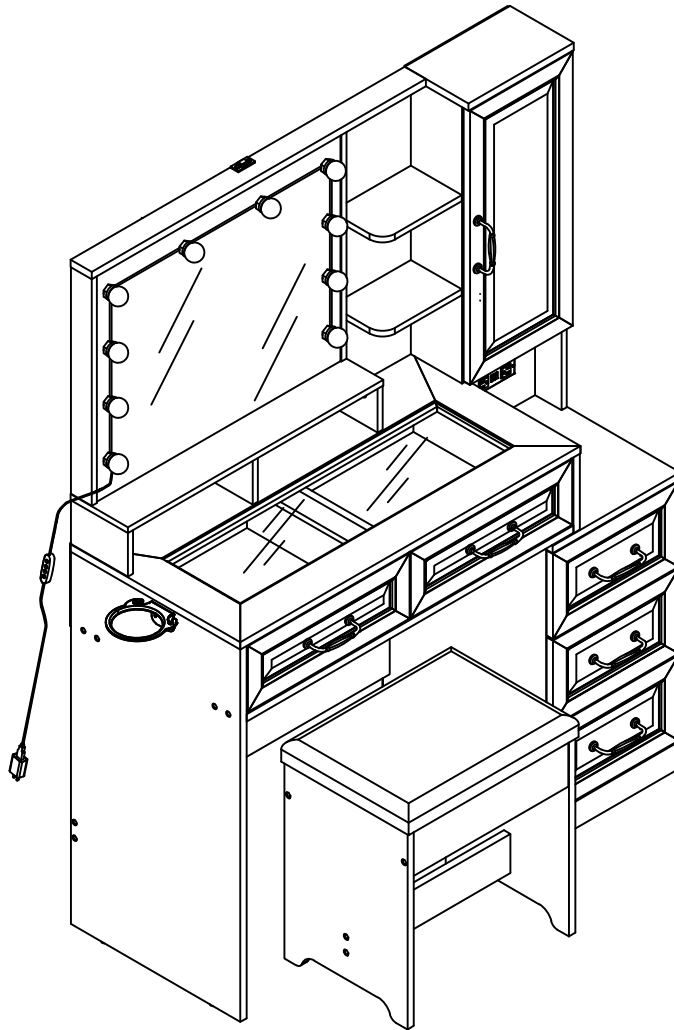

# JY9938HS01 JY9938BR01



As this item contains many parts, please read the installation instruction carefully before installation . Please use tools properly and carefully. If you have any questions about the product and installation, please contact us.

**service@vabchesofficial.com**

Our professional after-sales team will serve you online all day.

# Before You Start

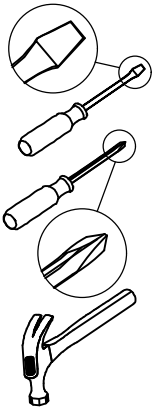

- ✓ Read through each step carefully and follow the proper order
- ✓ Separate and count all your parts and hardware
- ✓ Give yourself enough room for the assembly process
- ✓ Have the following tools: Flat Head Screwdriver, #2 Phillips Head Screwdriver and Hammer
- ✓ Caution: If using a power drill or power screwdriver for screwing, please pay attention to slow down and stop when screw is tight. Failure to do so may result in stripping the screw. (Assembly speed can be increased by using electric screwdriver)

# Helpful Hints

## PEOPLE NEEDED FOR ASSEMBLY:1-2

- Open your item in the area you plan to keep it to avoid excessive heavy lifting.
- Identify, sort and count the parts before attempting assembly.
- Compression dowels are lightly tapped in with a hammer.
- Slides are labeled with an R (right) and L (left) for proper placement.
- Make sure to always face the point on the top of the Cam Lock towards the outer edge.
- If there is a back panel in the package, please install it to make sure your unit is complete and sturdy.
- Please fix all the screws provided for the back panel which can enhance product stability. If it is difficult to fix it when tightening, it can be fixed with the help of a hammer and then tightened.
- Do NOT use harsh chemicals or abrasive cleaners on this item.
- Never push, pull, or drag your furniture.

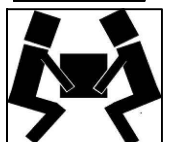

# Board Identification

Not actual size

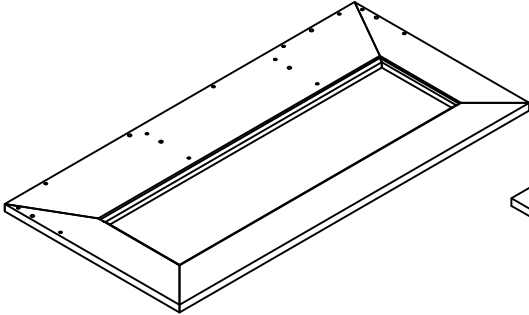

Ⓐ

TOP  
Qty:1

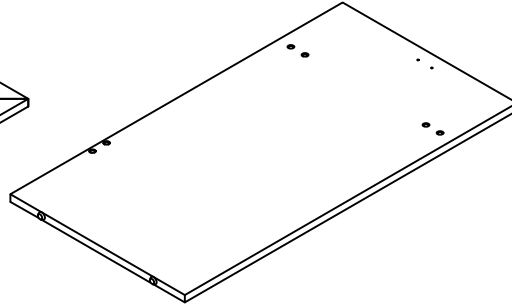

Ⓑ

LEFT SIDE PANEL  
Qty:1

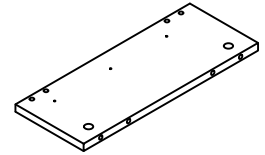

Ⓒ

RIGHT SIDE PANEL  
Qty:1

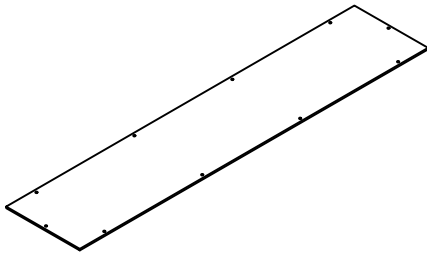

Ⓓ

DESK BACK PANEL  
Qty:1

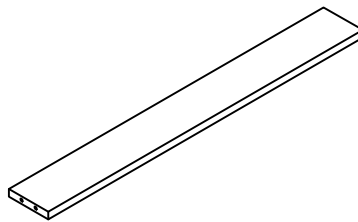

Ⓔ

LOWER BACK SLAT  
Qty:1

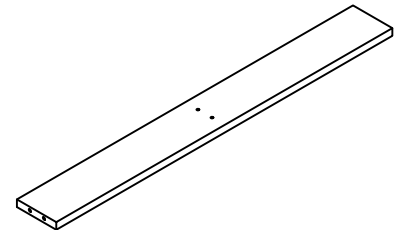

Ⓕ

FRONT SLAT  
Qty:1

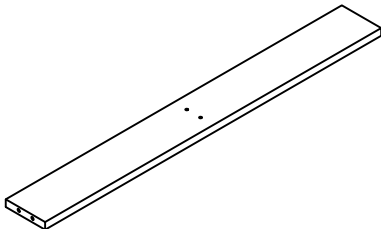

Ⓖ

BACK SLAT  
Qty:1

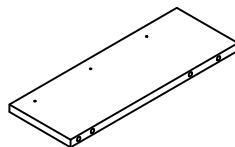

Ⓗ

MIDDLE PANEL  
Qty:1

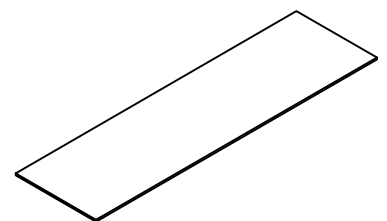

Ⓘ

DESKTOP GLASS  
Qty:1

# Board Identification

Not actual size

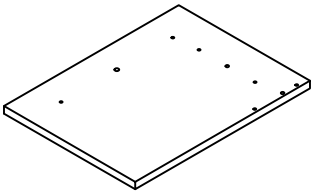

ⓐ

TOP  
Qty:1

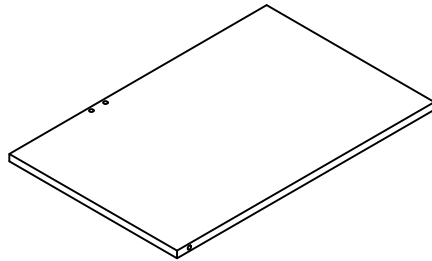

ⓑ

LEFT SIDE PANEL  
Qty:1

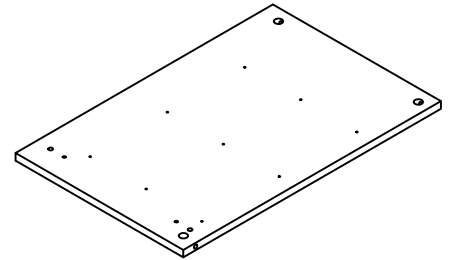

ⓒ

RIGHT SIDE PANEL  
Qty:1

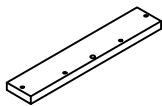

ⓓ

FRONT PANEL  
Qty:1

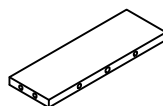

ⓔ

FRONT SLAT  
Qty:1

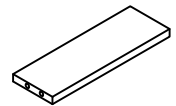

ⓕ

BACK SLAT  
Qty:1

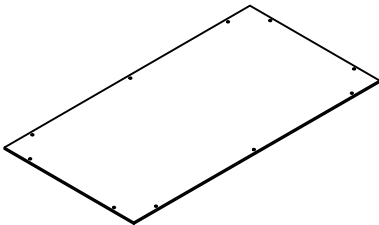

ⓖ

DESK BACK PANEL  
Qty:1

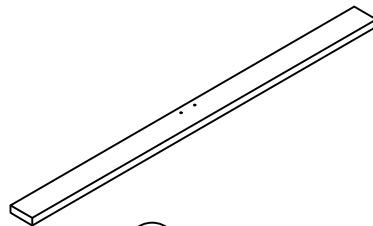

ⓗ

FIXED SHELF  
Qty:1

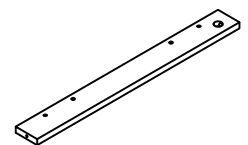

ⓘ

UPPER LEFT SIDE PANEL  
Qty:1

# Board Identification

Not actual size

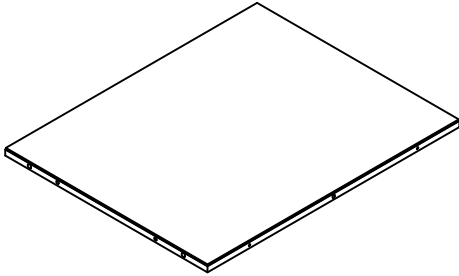

Ⓢ

DRESSING MIRROR  
Qty:1

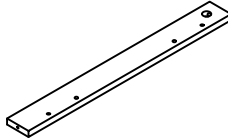

Ⓣ

UPPER LEFT MIDDLE PANEL  
Qty:1

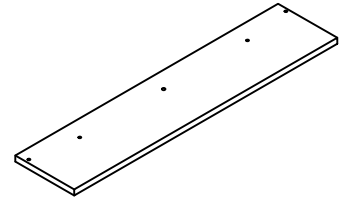

Ⓤ

HUTCH FIXED SHELF  
Qty:1



Ⓥ

HUTCH SIDE PANEL  
Qty:1



Ⓦ

HUTCH SIDE PANEL  
Qty:1

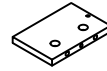

Ⓧ

HUTCH SIDE PANEL  
Qty:1

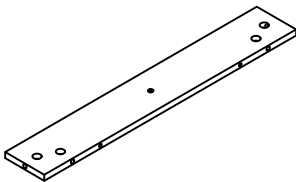

Ⓨ

DESK BACK PANEL  
Qty:1

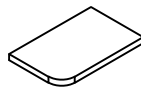

Ⓩ

FIXED SHELF  
Qty:2

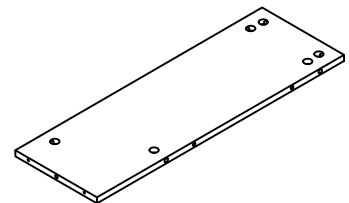

ⒶⒶ

DESK BACK PANEL  
Qty:1

# Board Identification

Not actual size

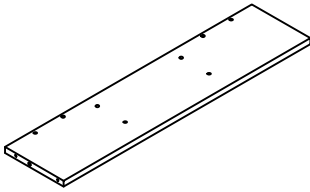

ⓑ

UPPER RIGHT MIDDLE PANEL  
Qty:1

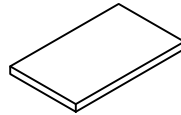

ⓒ

FIXED SHELF  
Qty:1

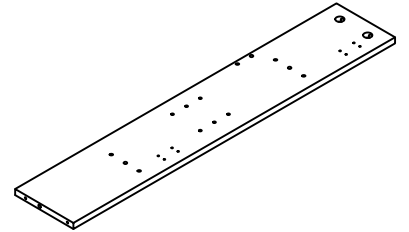

ⓓ

UPPER RIGHT SIDE PANEL  
Qty:1

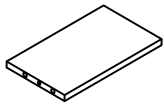

ⓔ

FIXED SHELF  
Qty:1

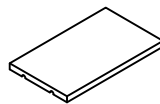

ⓕ

FIXED SHELF  
Qty:1

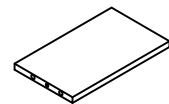

ⓖ

FIXED SHELF  
Qty:1

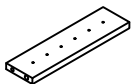

ⓓⓓ

HUTCH FIXED SHELF  
Qty:1

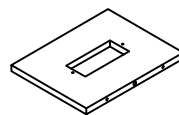

ⓓⓓ

FIXED SHELF  
Qty:1

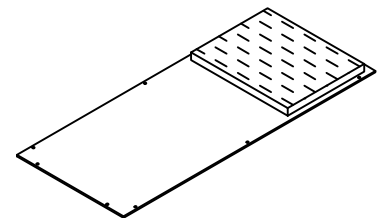

ⓓⓓ

DESK BACK PANEL  
Qty:1

# Board Identification

Not actual size

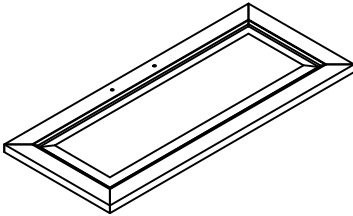

ⓀⓀ

DOOR  
Qty:1

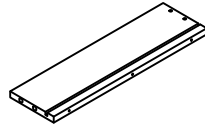

ⓁⓁ

DRAWER LEFT SIDE  
Qty:2

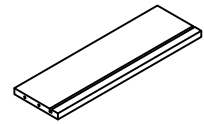

ⓂⓂ

DRAWER BACK PANEL  
Qty:2

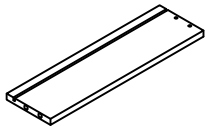

ⓃⓃ

DRAWER RIGHT SIDE  
Qty:2

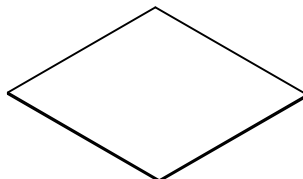

ⓄⓄ

DRAWER BOTTOM  
Qty:2

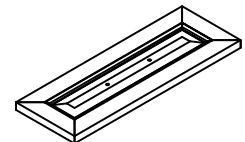

ⓅⓅ

LEFT DRAWER FRONT  
Qty:1

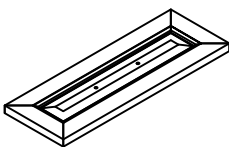

ⓆⓆ

RIGHT DRAWER FRONT  
Qty:1

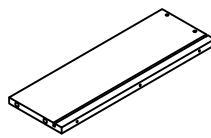

ⓇⓇ

DRAWER LEFT SIDE  
Qty:3

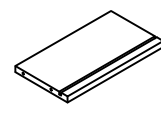

ⓈⓈ

DRAWER BACK PANEL  
Qty:3

# Board Identification

Not actual size

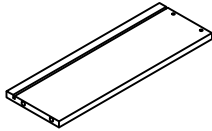

ⓉⓉ

DRAWER RIGHT SIDE  
Qty:3

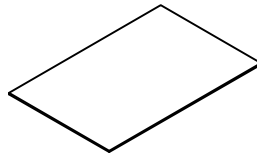

ⓊⓊ

DRAWER BOTTOM  
Qty:3

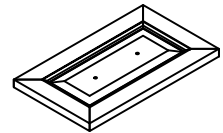

ⓋⓋ

RIGHT DRAWER FRONT  
Qty:3

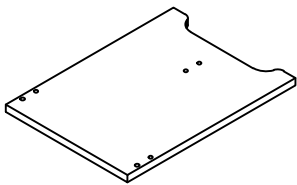

ⓌⓌ

STOOL SIDE PANEL  
Qty:2

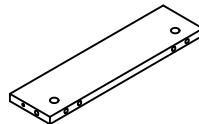

ⓍⓍ

STOOL APRON  
Qty:2

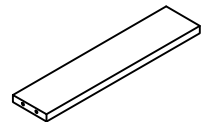

ⓎⓎ

STOOL LOWER SLAT  
Qty:1

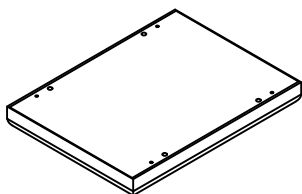

ⓏⓏ

SPONGE CUSHION  
Qty:1



# Part List

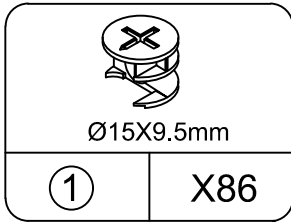

CAM LOCK  
spare:3

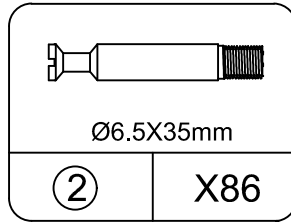

CAM BOLT  
spare:3

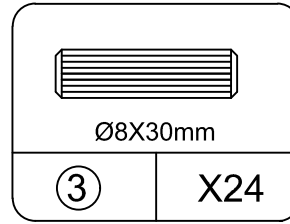

WOOD DOWEL  
spare:2

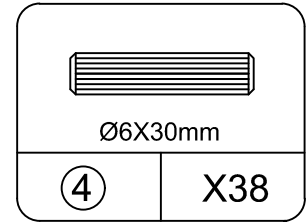

WOOD DOWEL  
spare:3

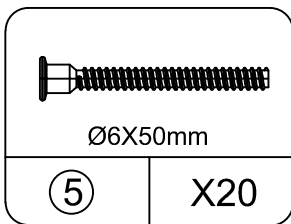

SCREW  
spare:2

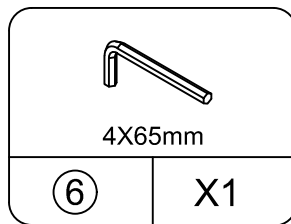

HEX KEY

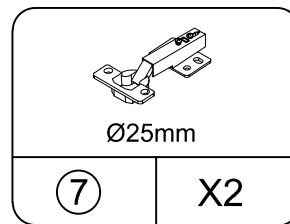

HINGE

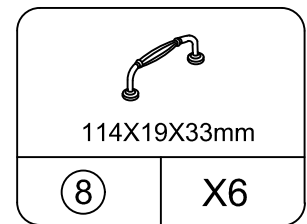

HANDLE

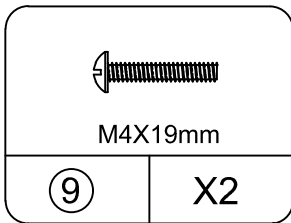

SCREW

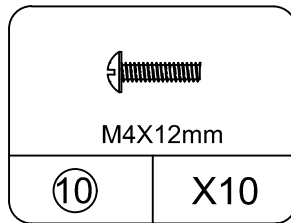

SCREW  
spare:1

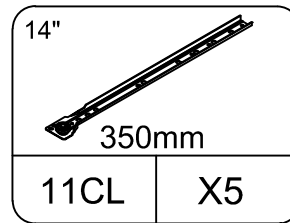

LEFT CABINET MEMBER

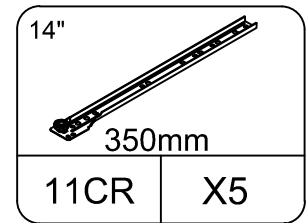

RIGHT CABINET MEMBER

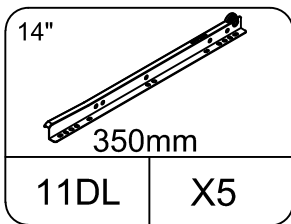

LEFT DRAWER RUNNER

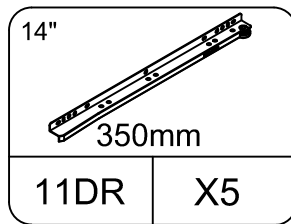

RIGHT DRAWER RUNNER

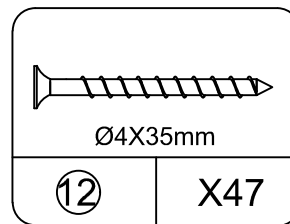

SCREW  
spare:3

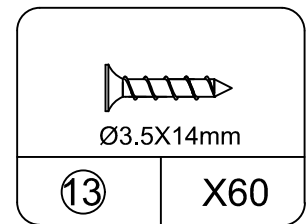

SCREW  
spare:3

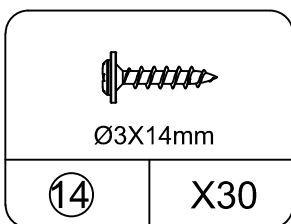

SCREW  
spare:2

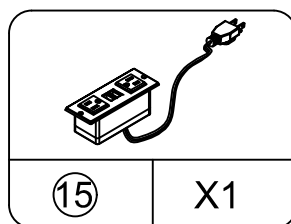

POWER STRIP

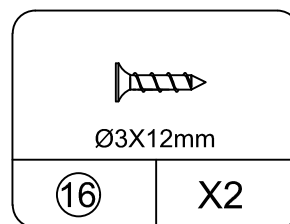

SCREW  
spare:1

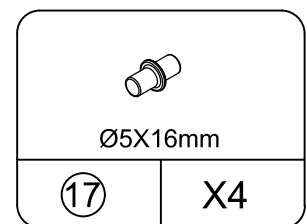

SHELF SUPPORT  
spare:1

# Part List

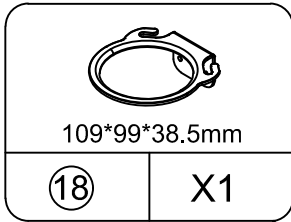

⑱ X1

HAIR DRYER RACK

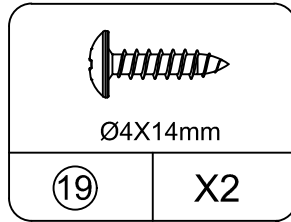

⑲ X2

SCREW  
spare:1

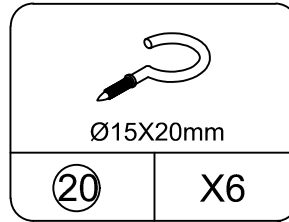

⑳ X6

HOOKING  
spare:1

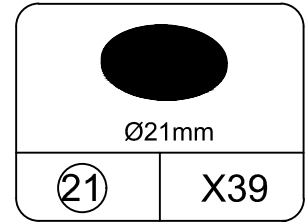

㉑ X39

PERFECT STICKER  
spare:3

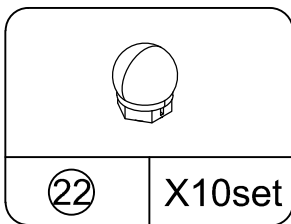

㉒ X10set

LIGHT BULB

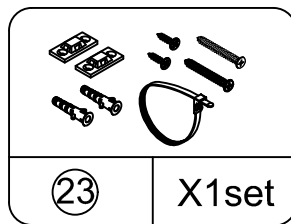

㉓ X1set

HIPPING RESTRAINT  
HARDWARE KIT

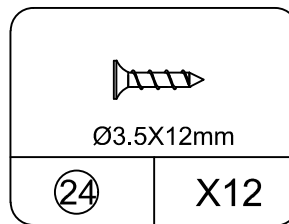

㉔ X12

SCREW  
spare:1

## Cam Lock Fastening System

Insert the cam bolt into the hole first, then insert the cam lock and lock it.

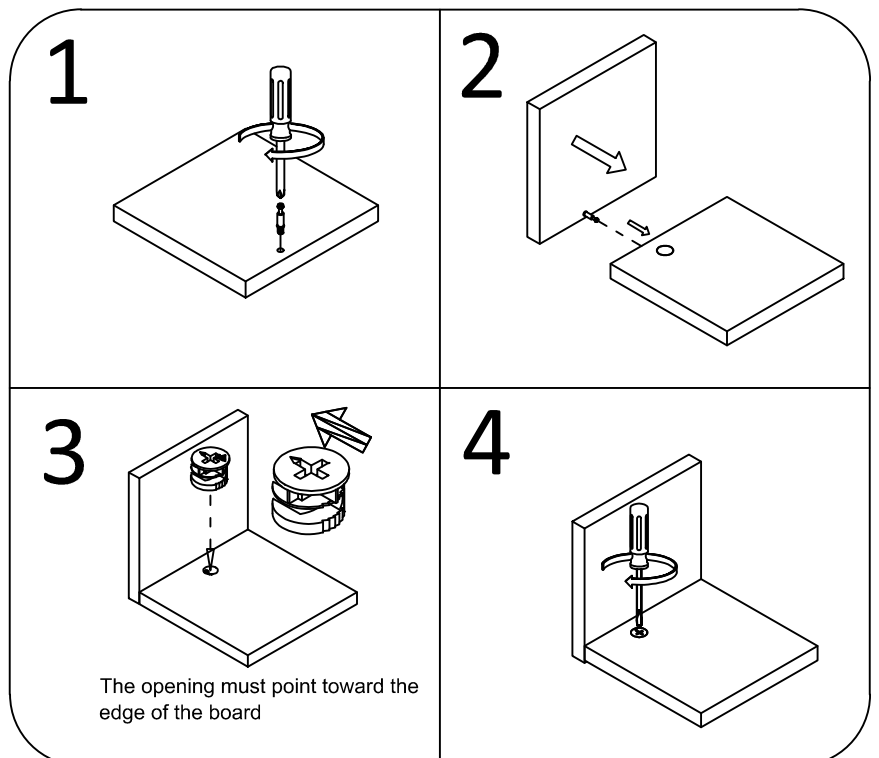

# Board Identification

Not actual size

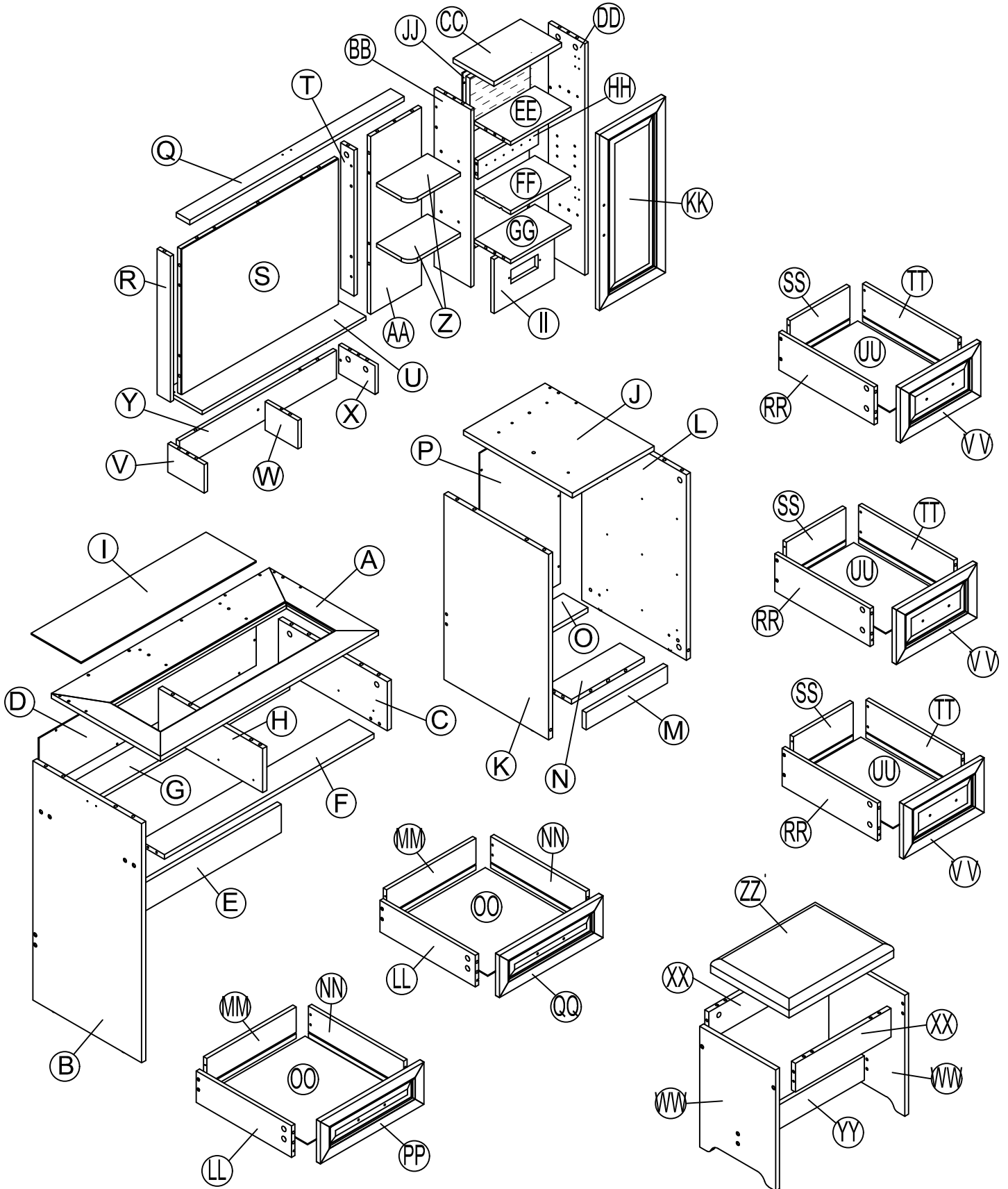

# STEP 1

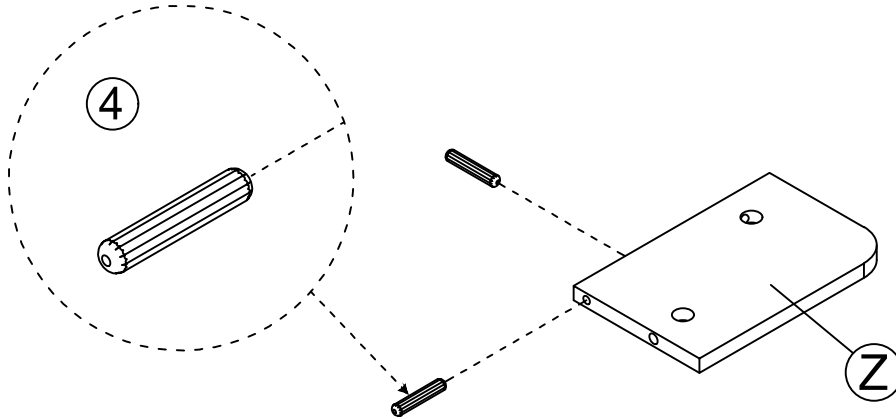
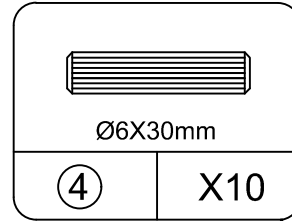
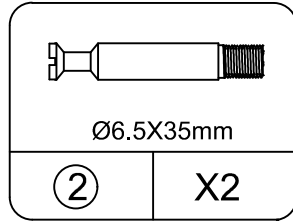
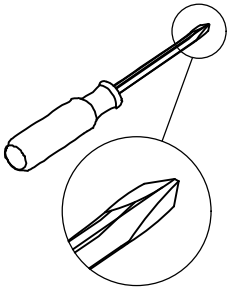

X2

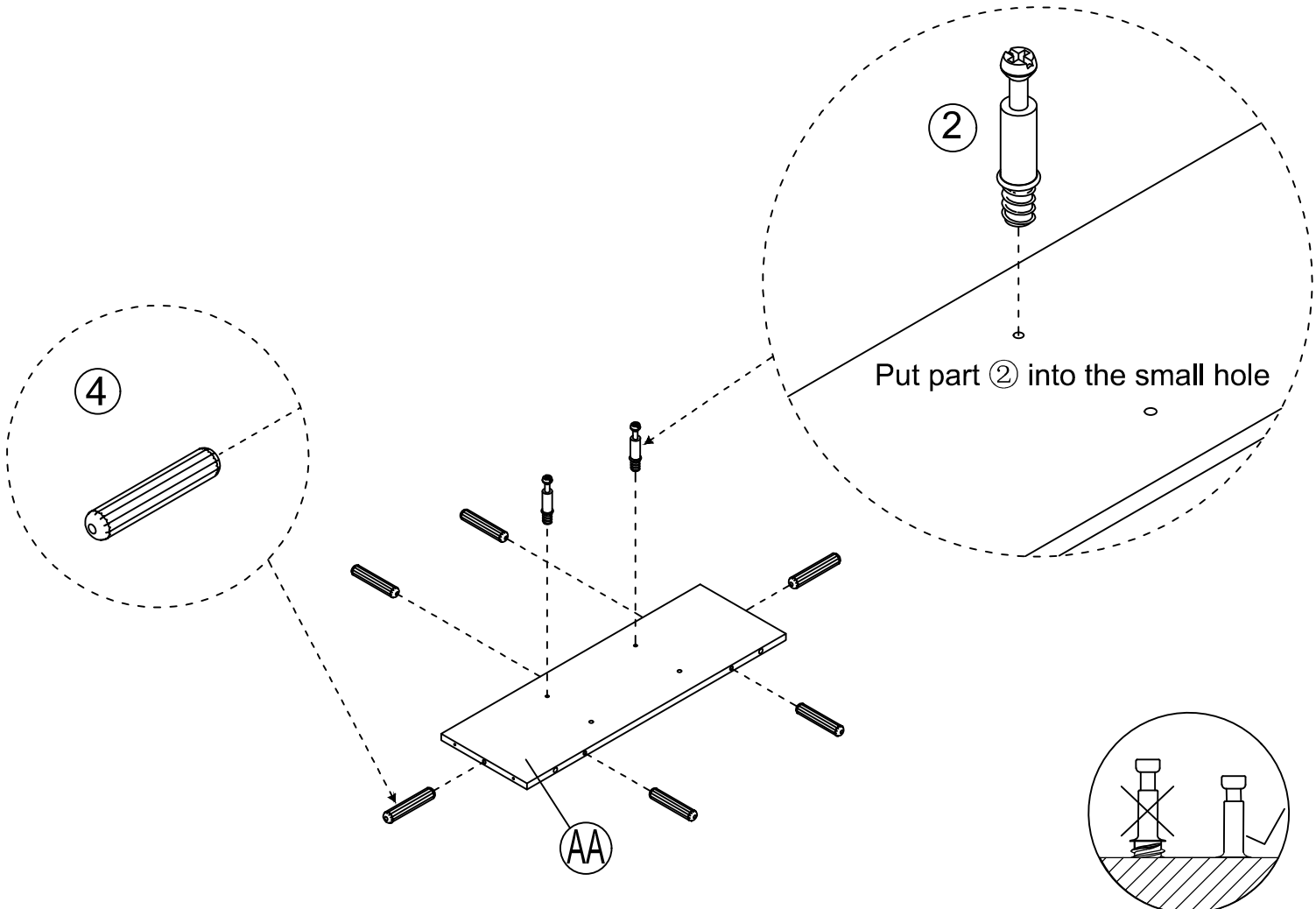

# STEP2

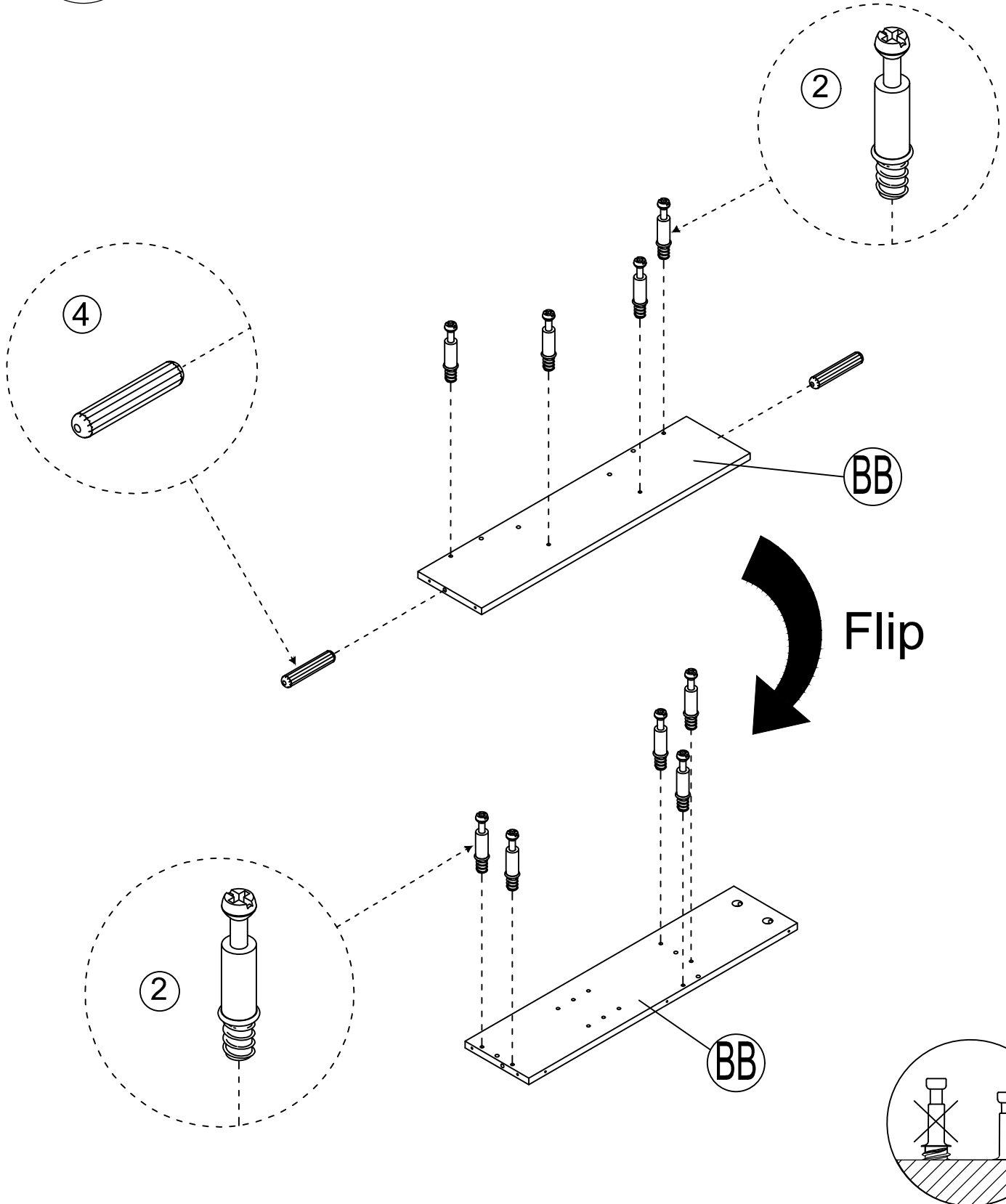
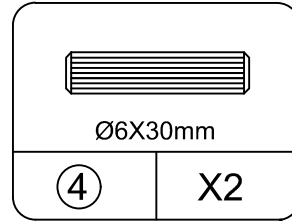
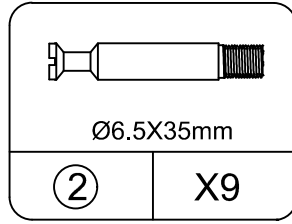
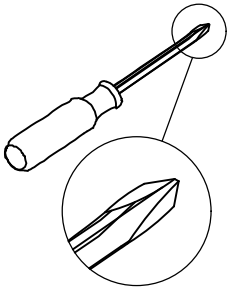

# STEP3

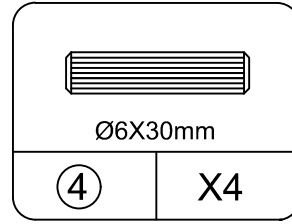
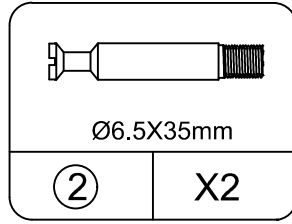
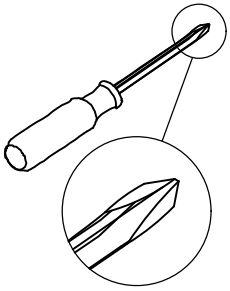

**WITHOUT EDGE BANDING**

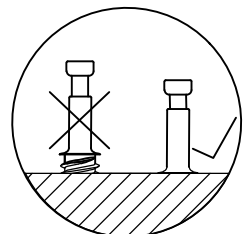
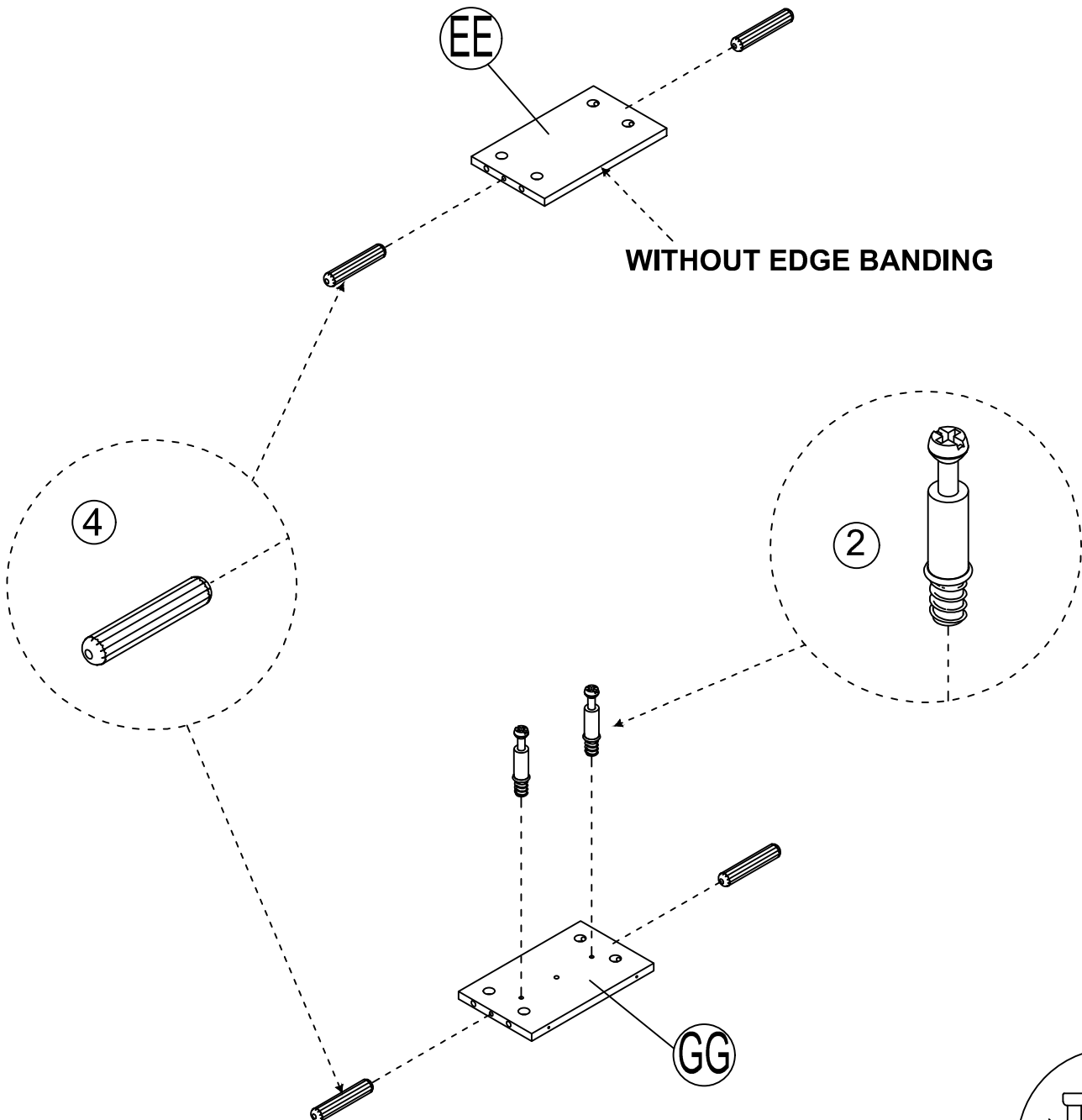

# STEP 4

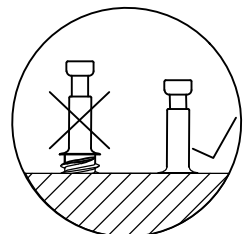
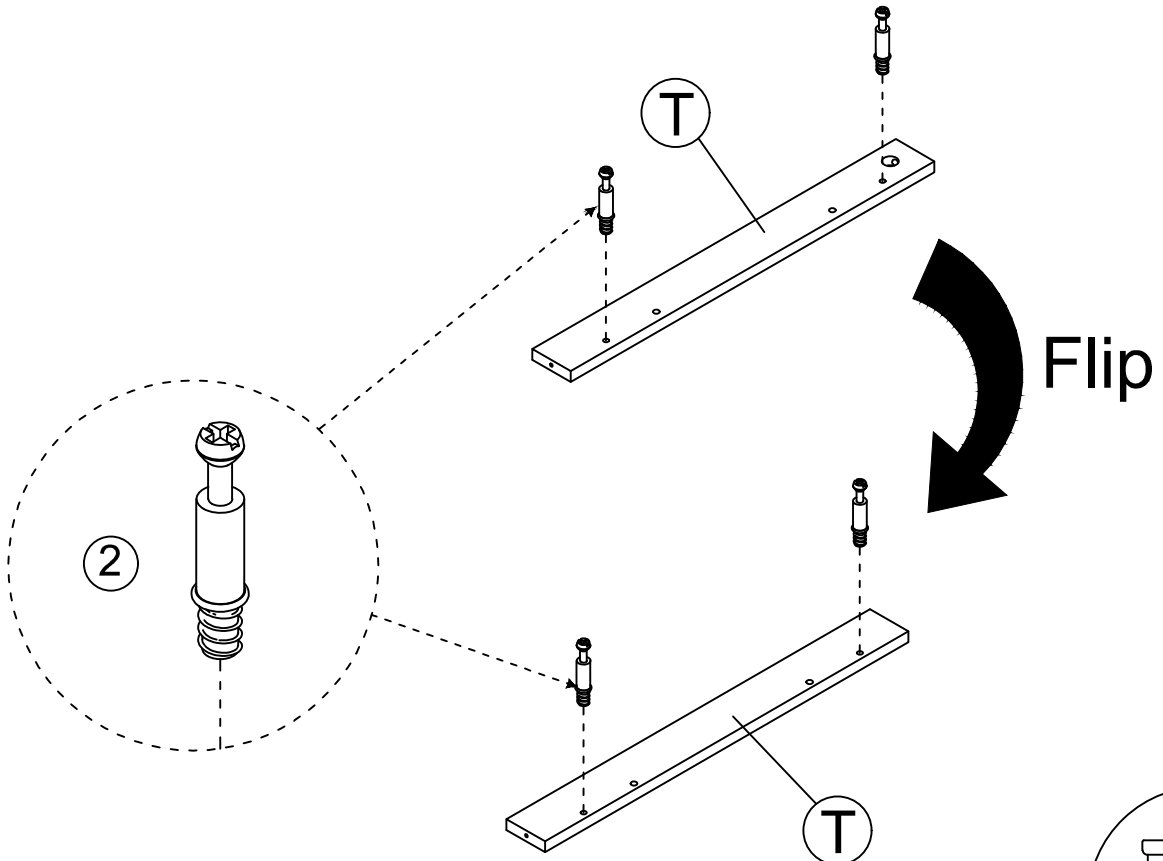
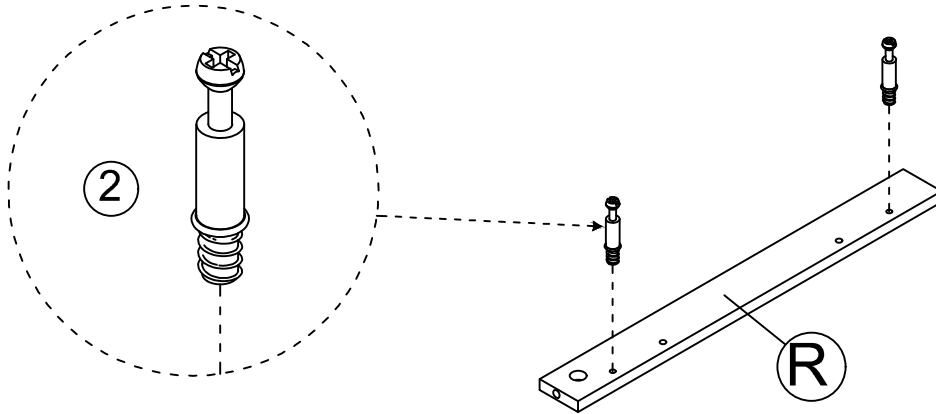
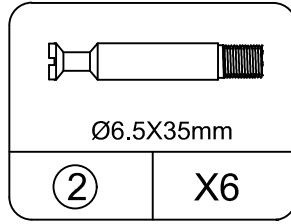
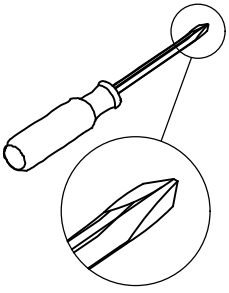

# STEP 5

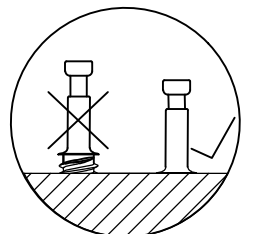
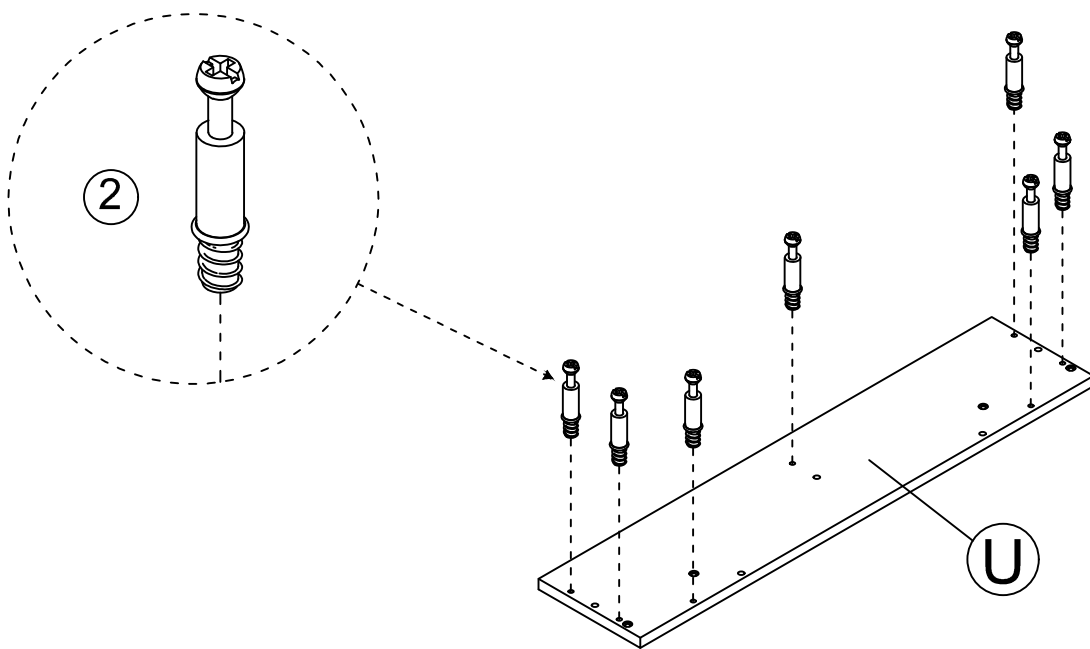
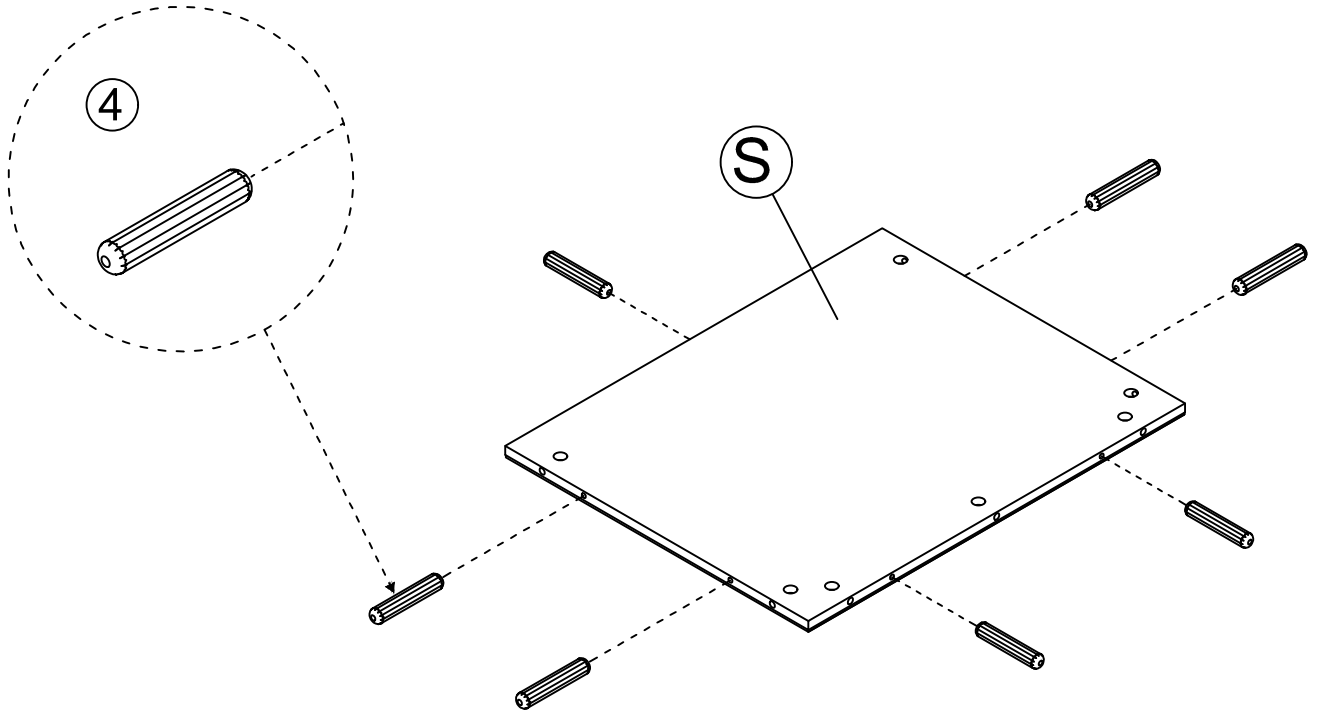
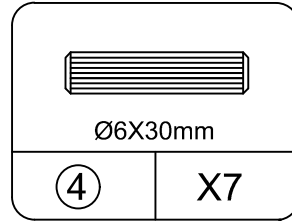
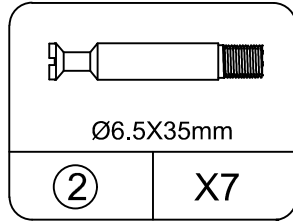
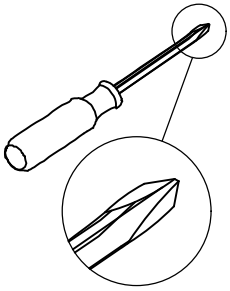



# STEP 6

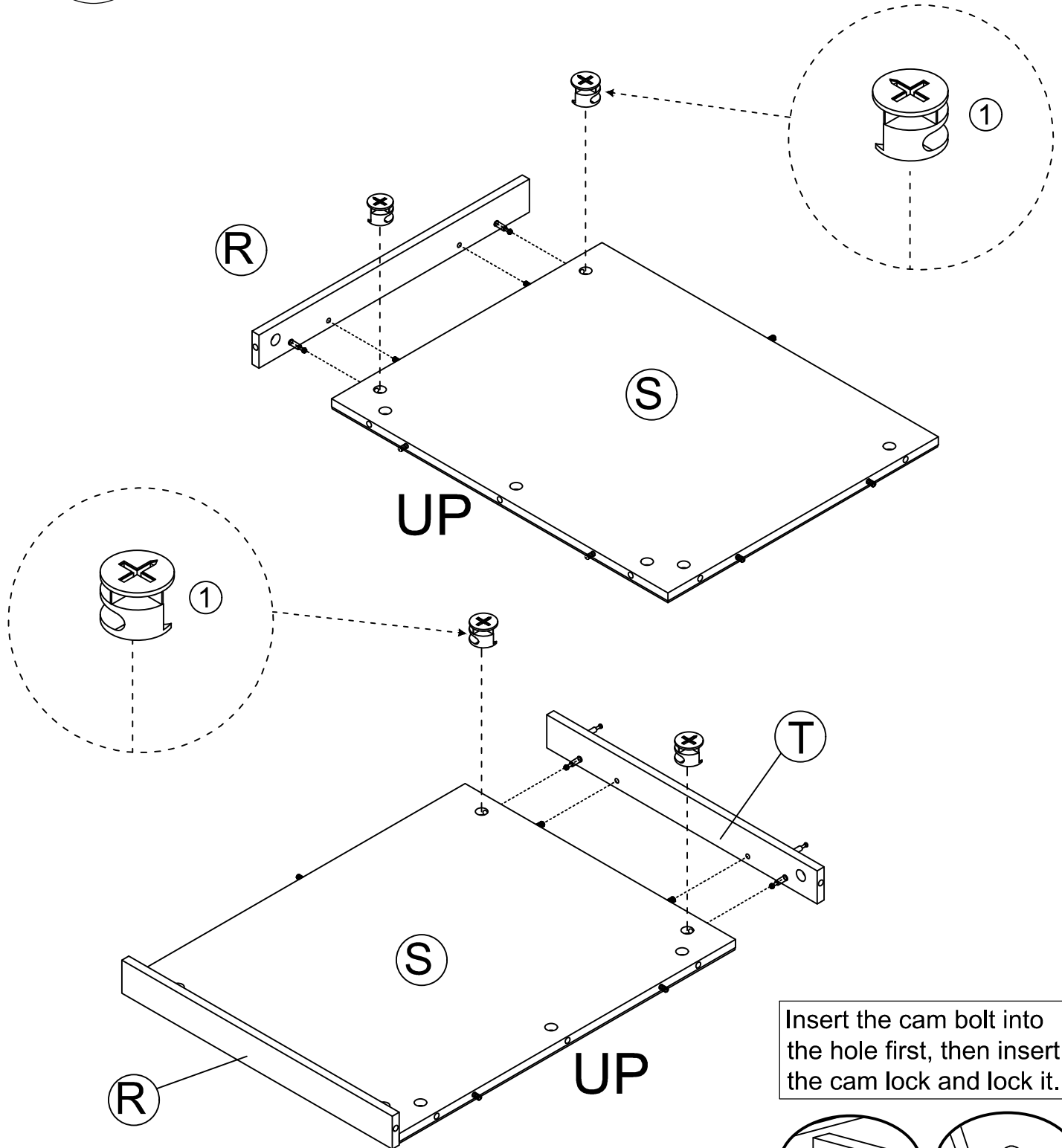
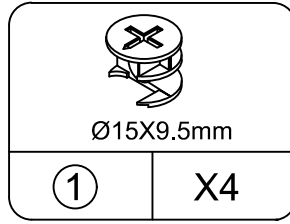
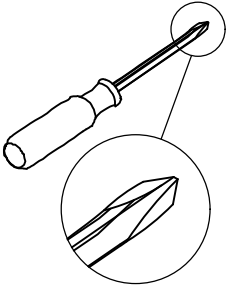

Insert the cam bolt into the hole first, then insert the cam lock and lock it.

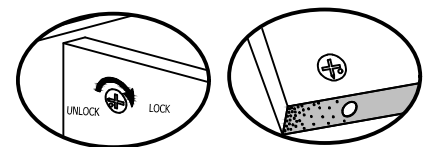

# STEP 7

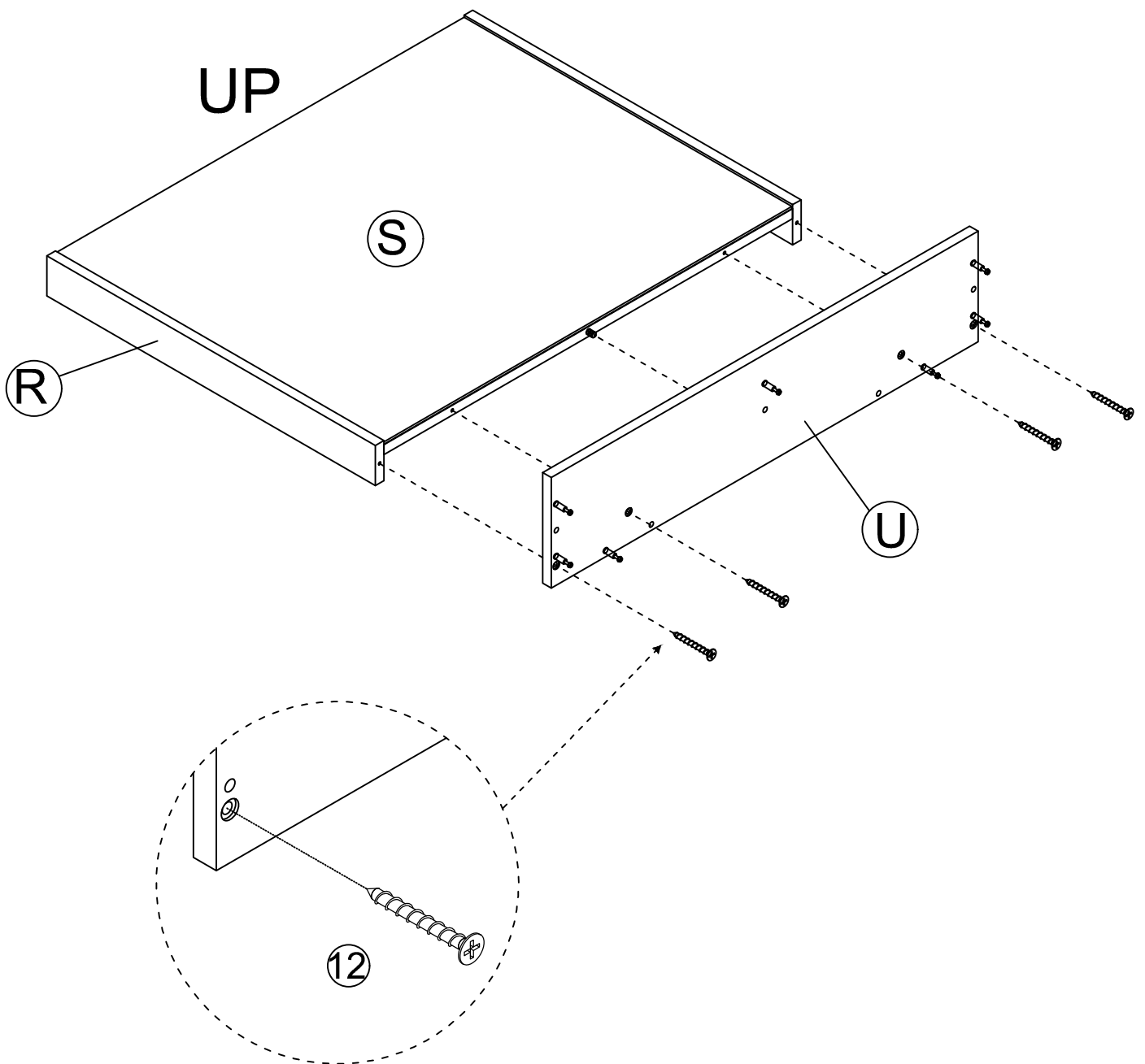
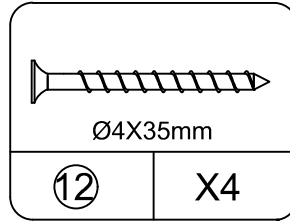
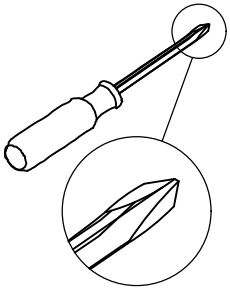

# STEP 8

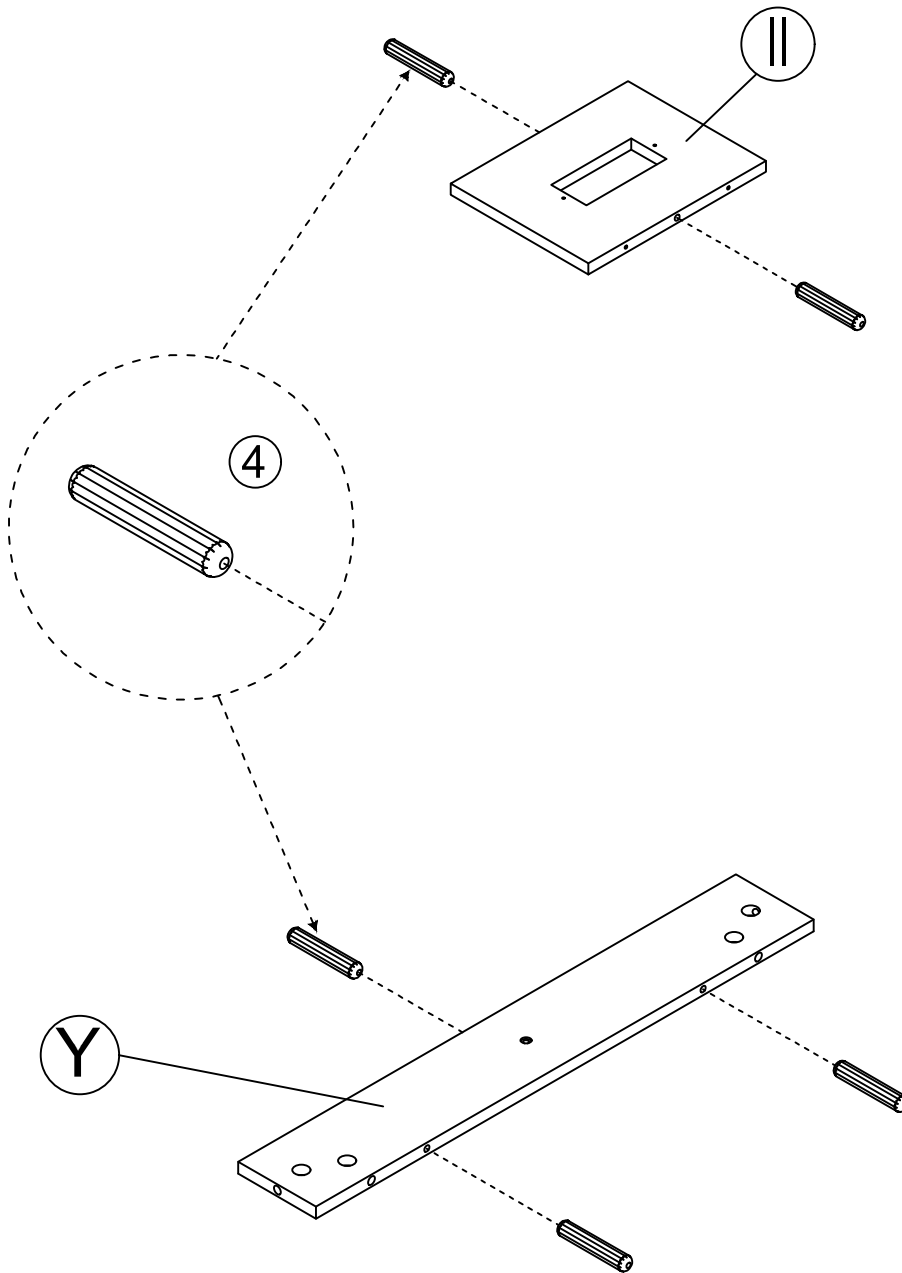
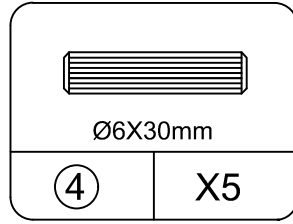
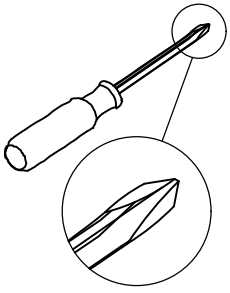

# STEP 9

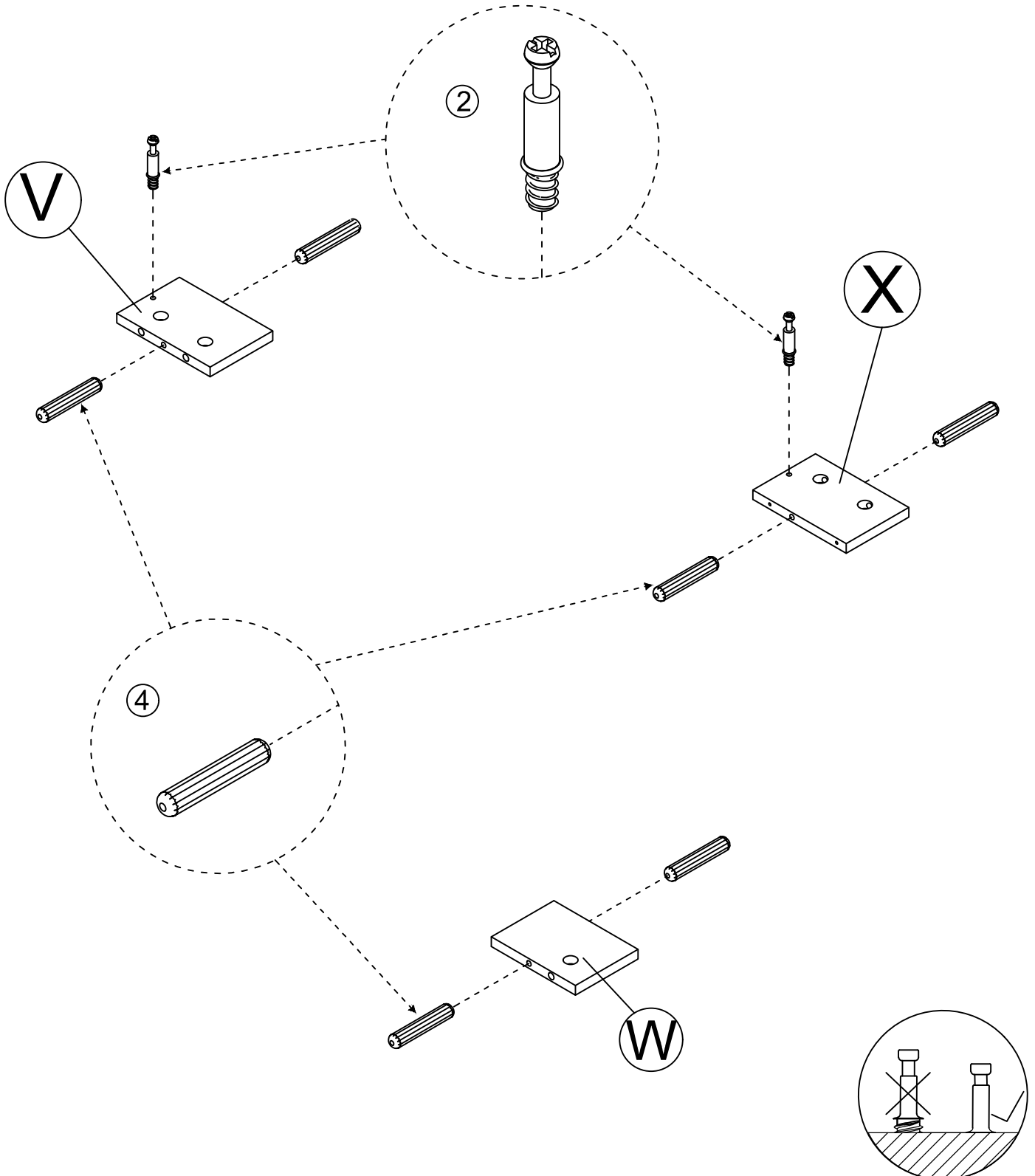
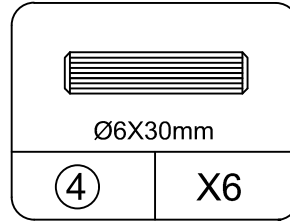
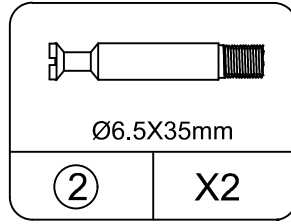
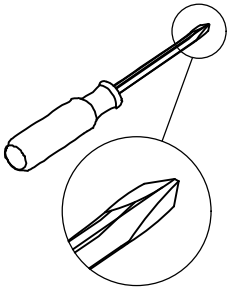

# STEP10

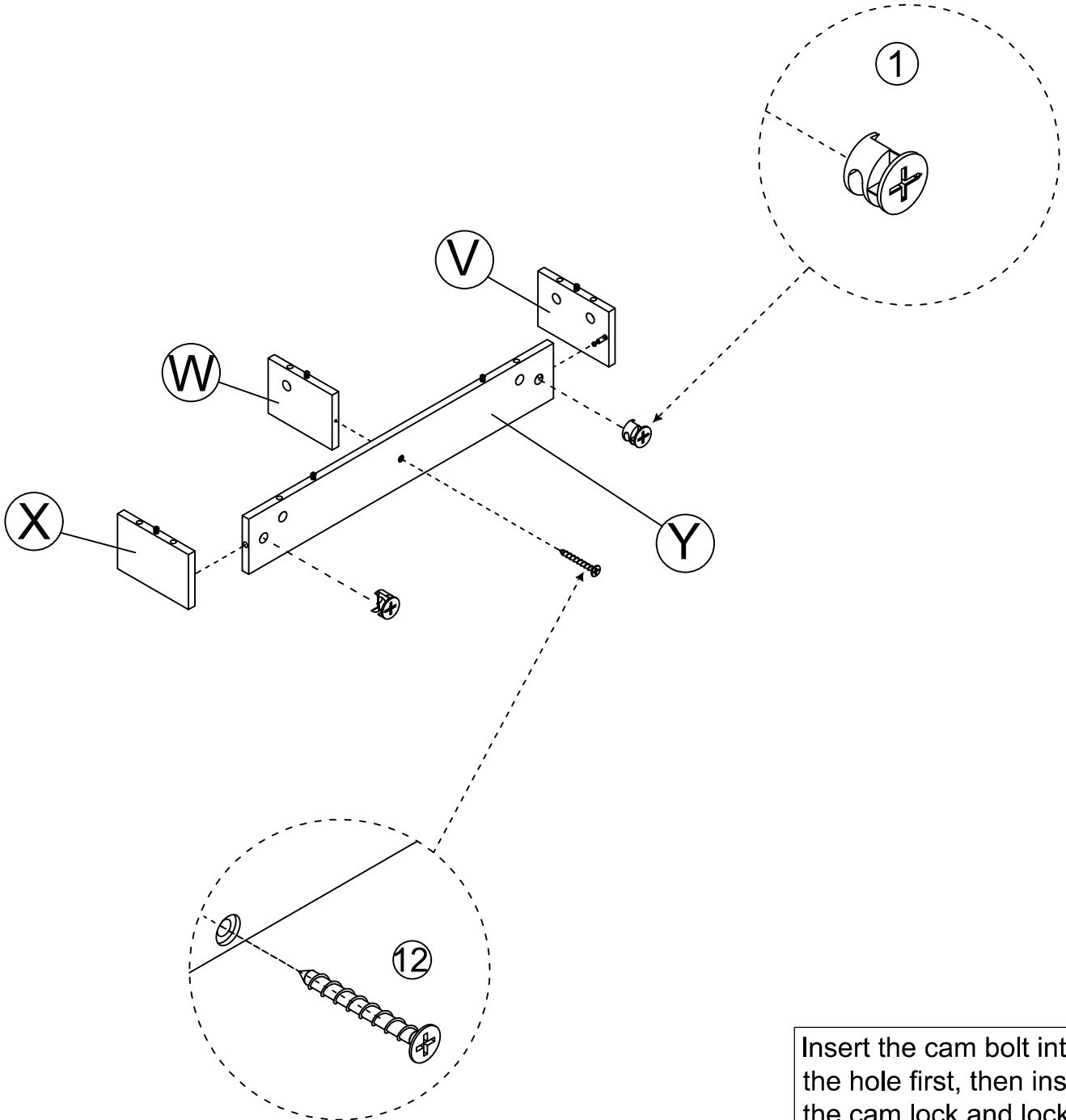
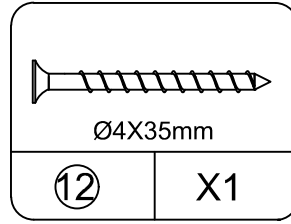
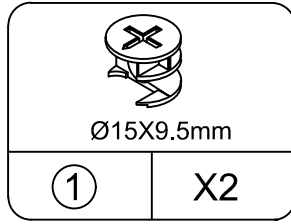
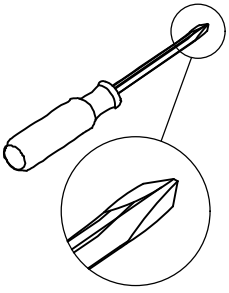

Insert the cam bolt into the hole first, then insert the cam lock and lock it.

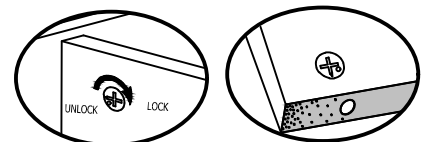

Proper orientation of CAM LOCK

# STEP11

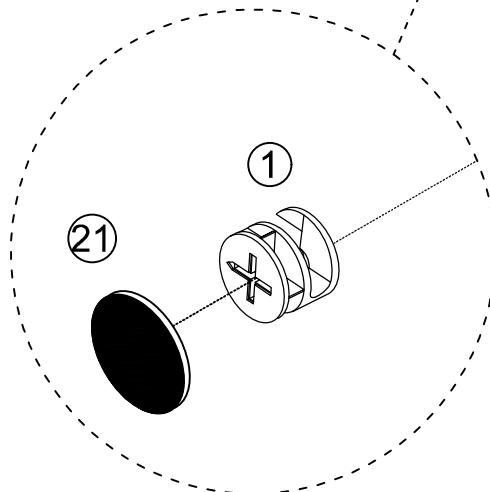
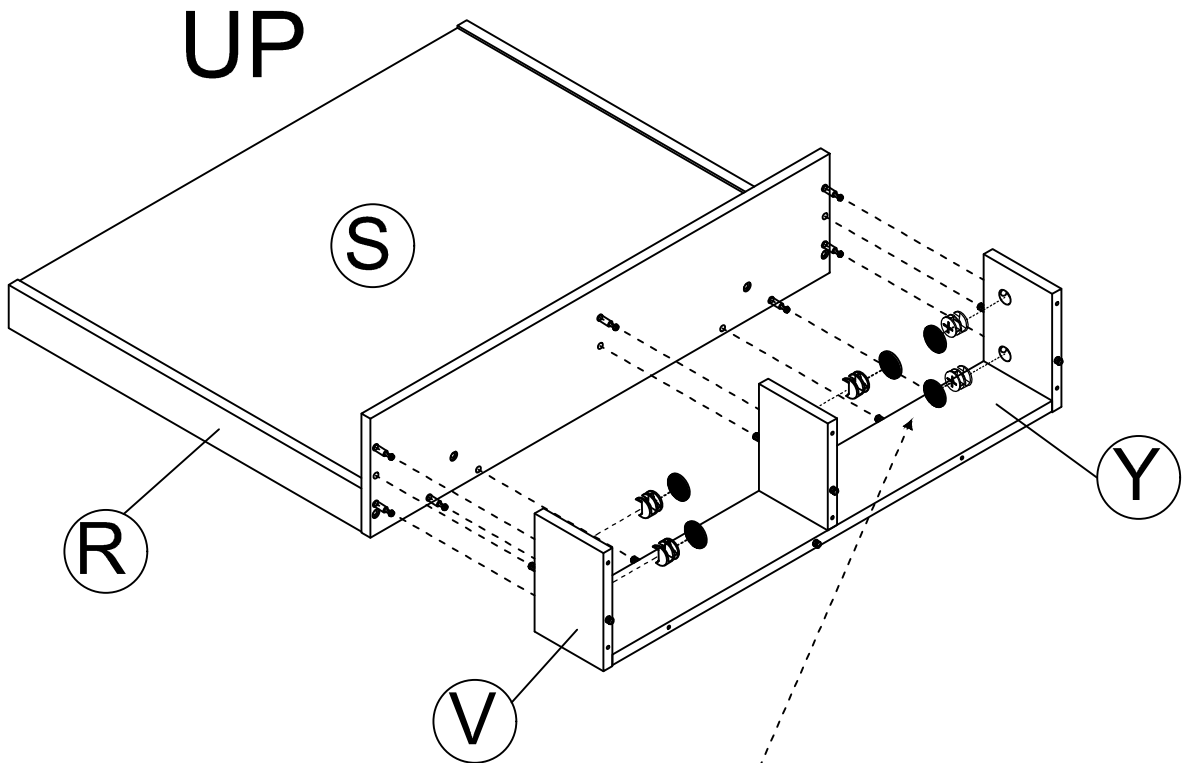
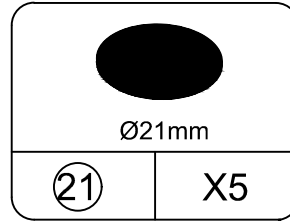
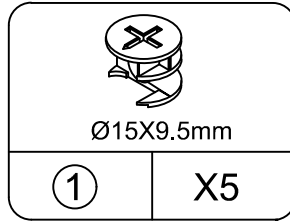
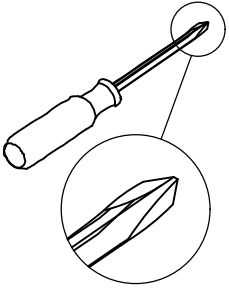

Insert the cam bolt into the hole first, then insert the cam lock and lock it.

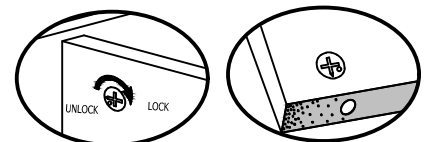

Proper orientation of CAM LOCK

# STEP12

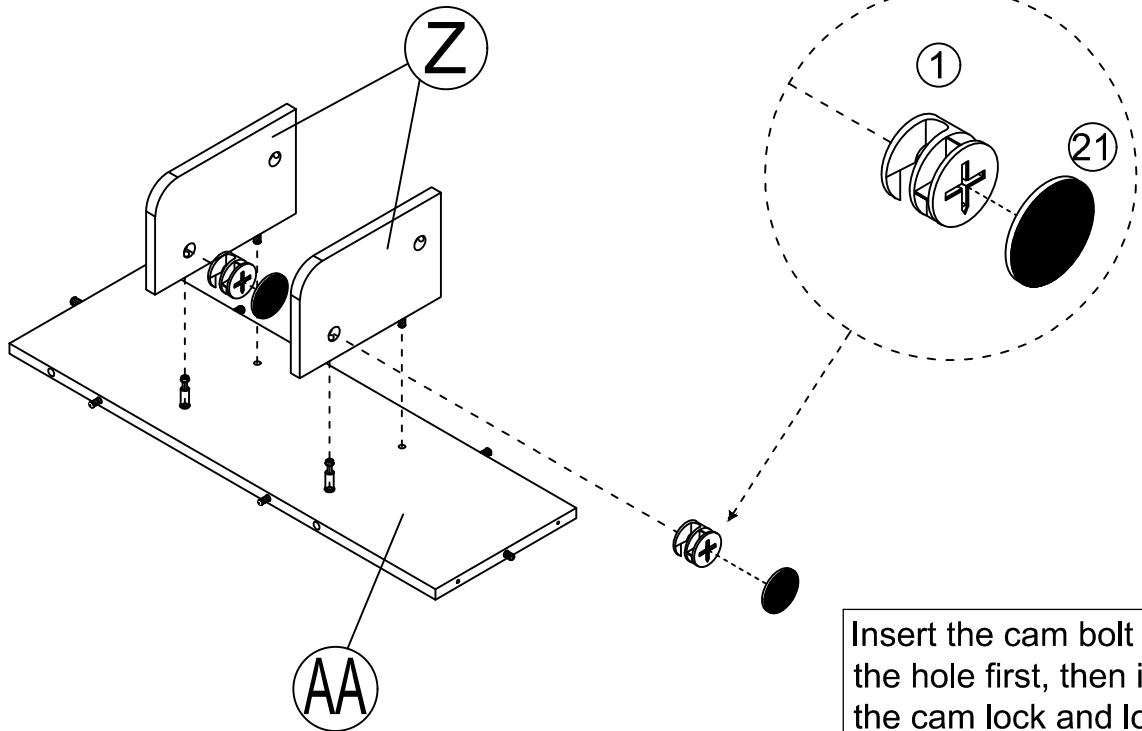
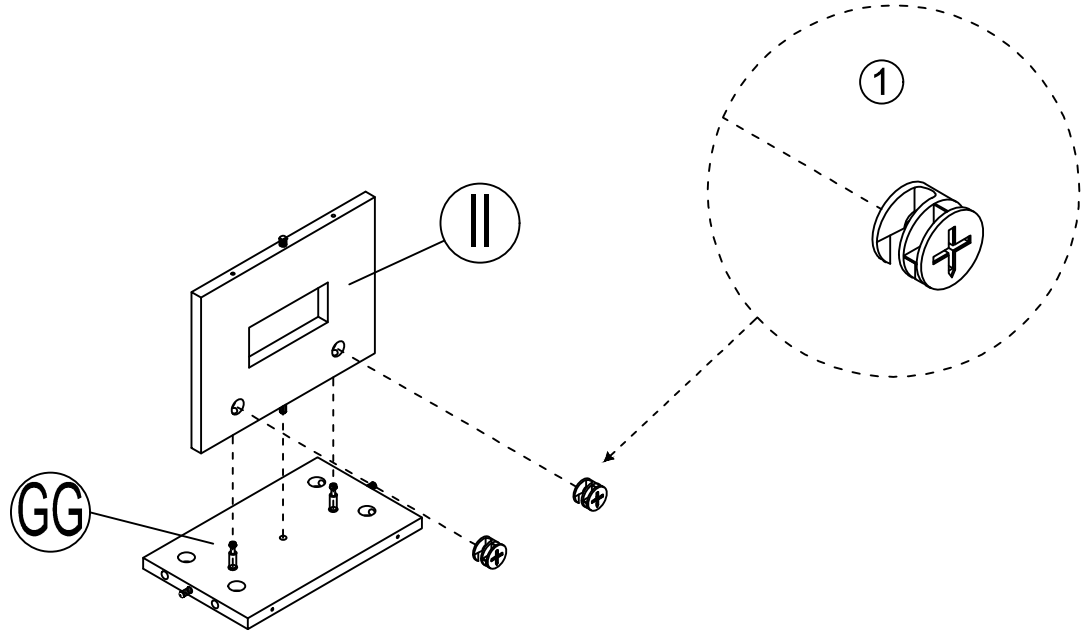
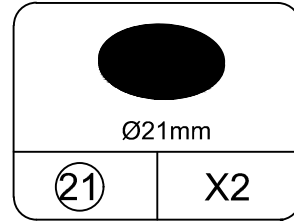
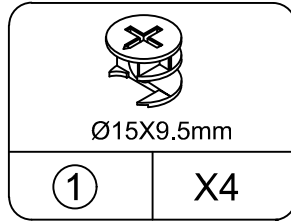
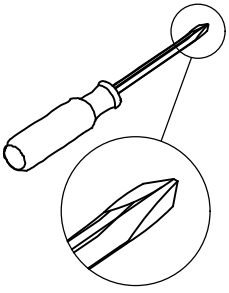

Insert the cam bolt into the hole first, then insert the cam lock and lock it.

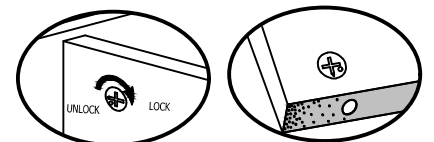

Proper orientation of CAM LOCK

# STEP13

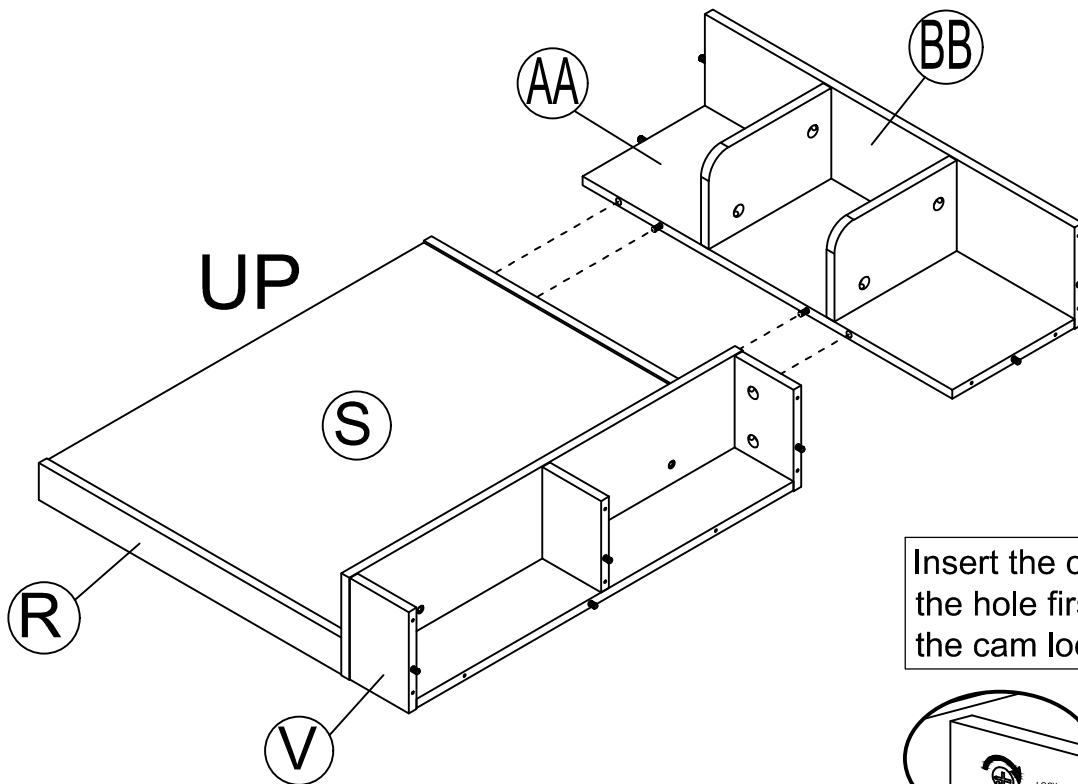
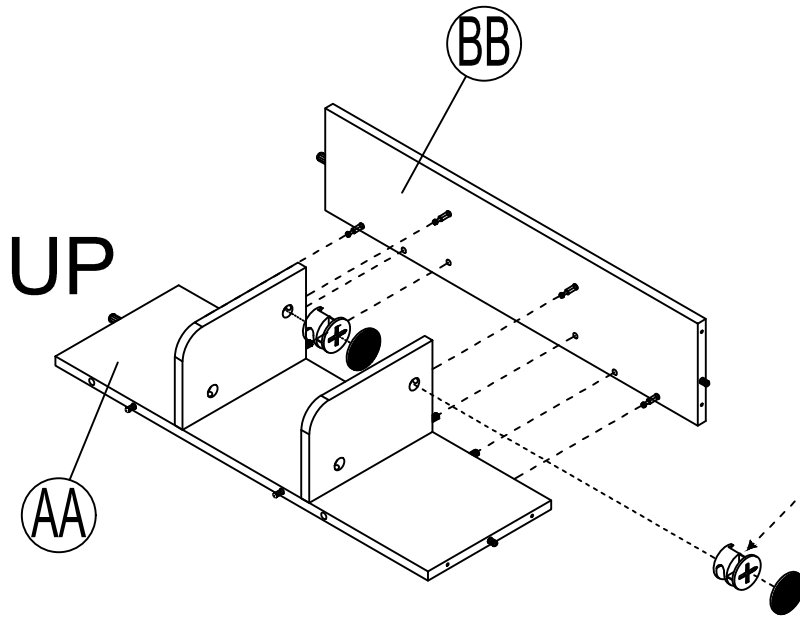
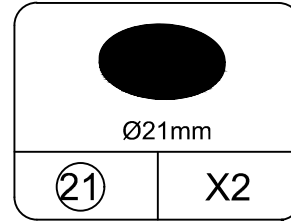
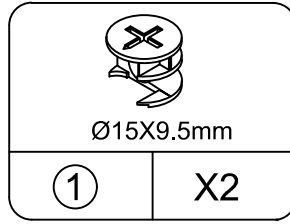
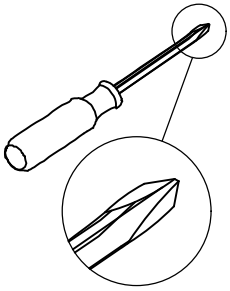

Insert the cam bolt into the hole first, then insert the cam lock and lock it.

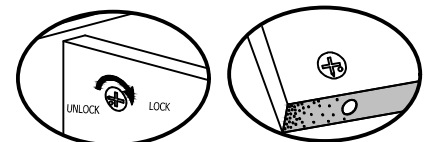

Proper orientation of CAM LOCK



# STEP14

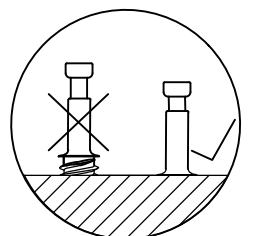
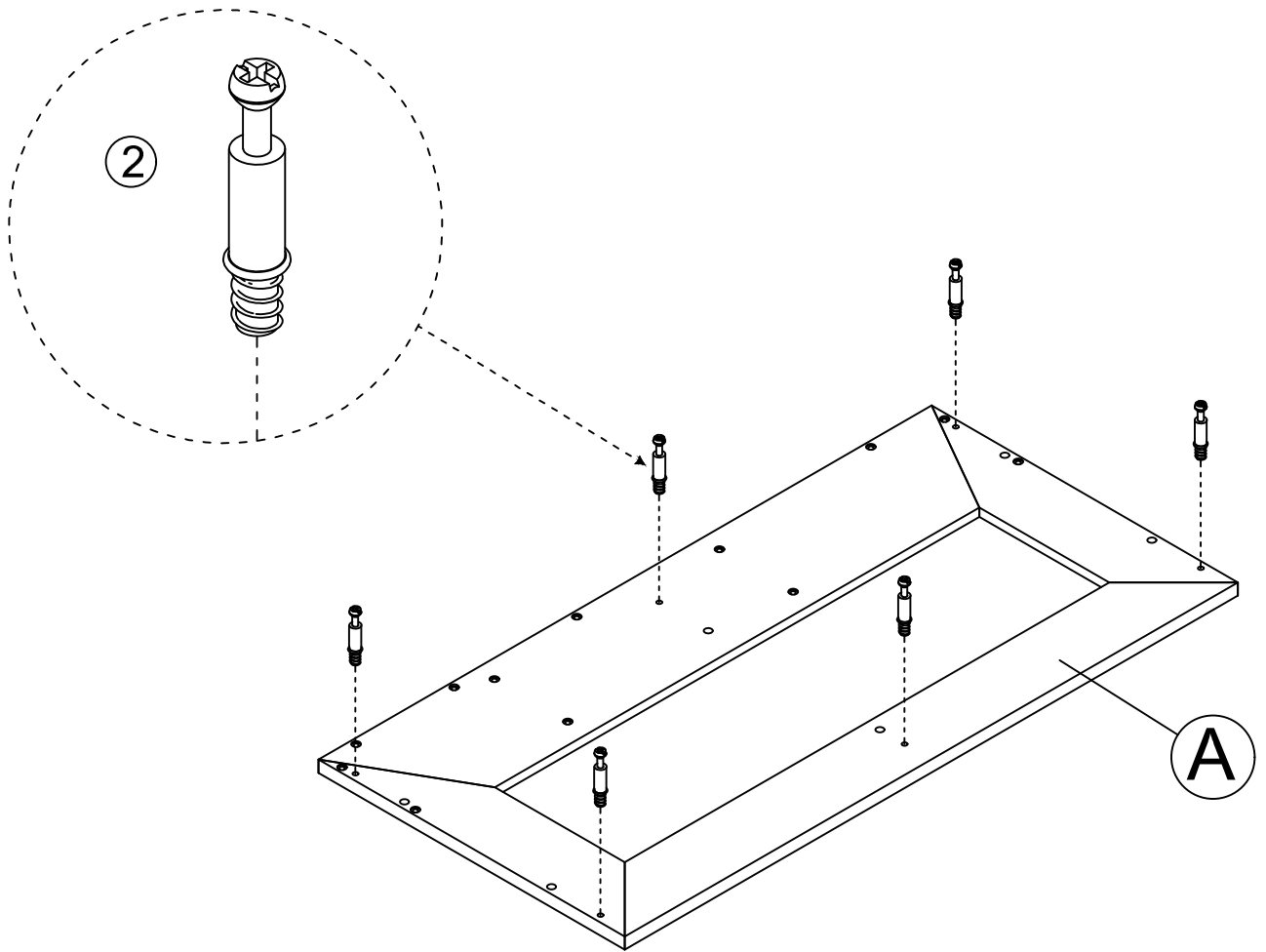
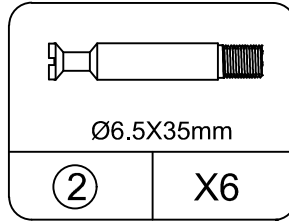
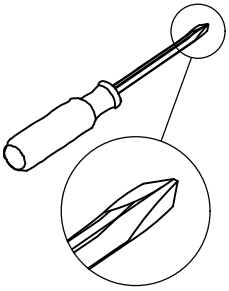

# STEP15

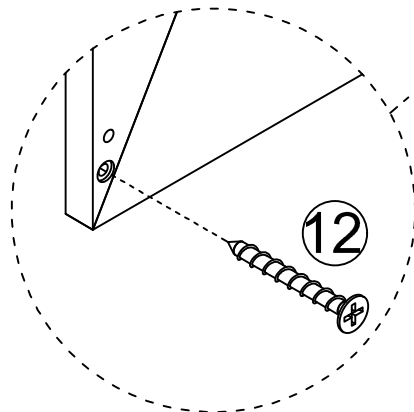
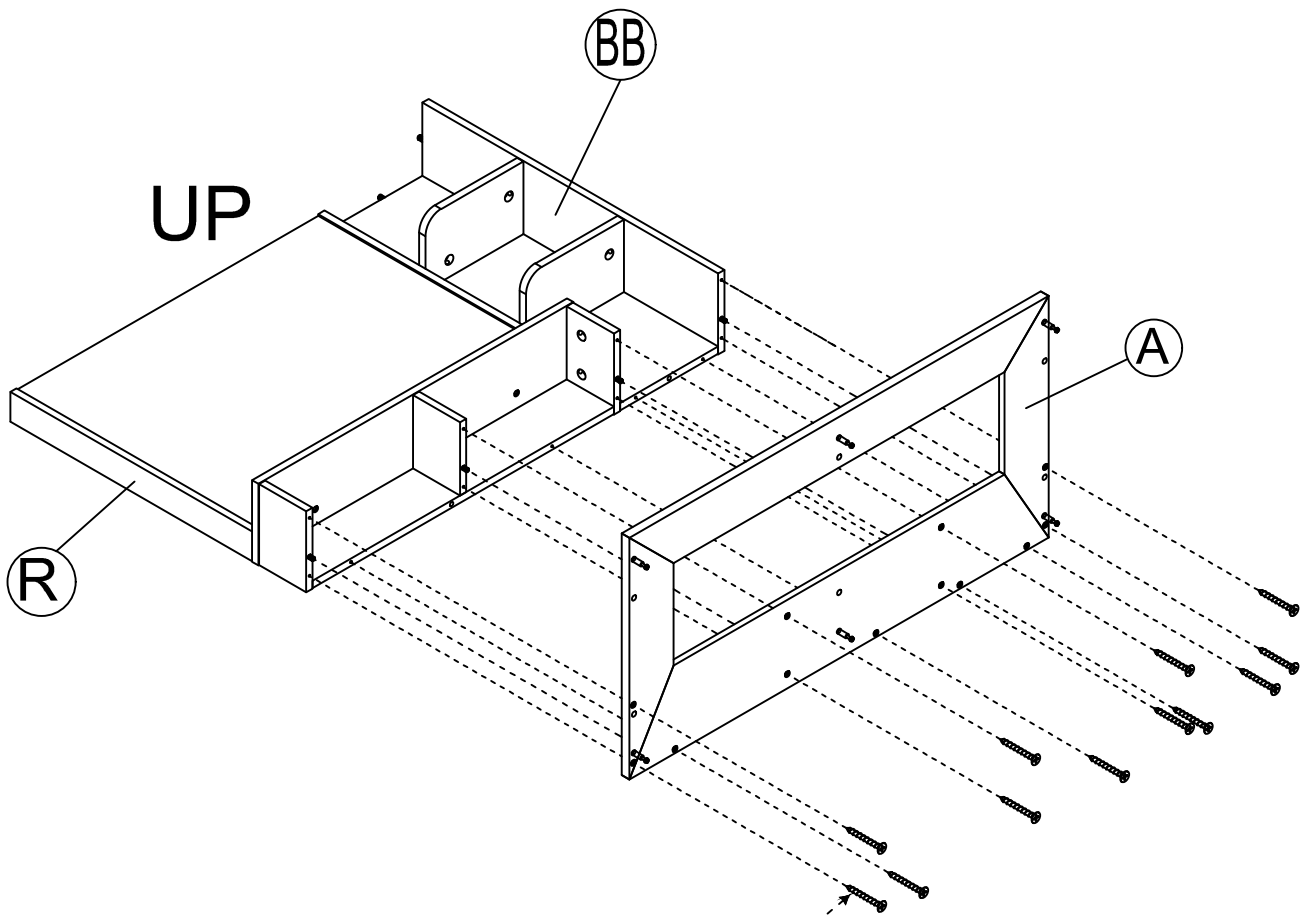
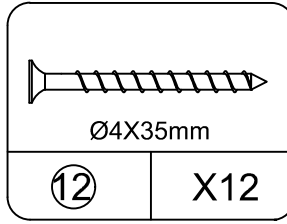
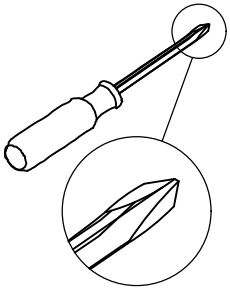

# STEP16

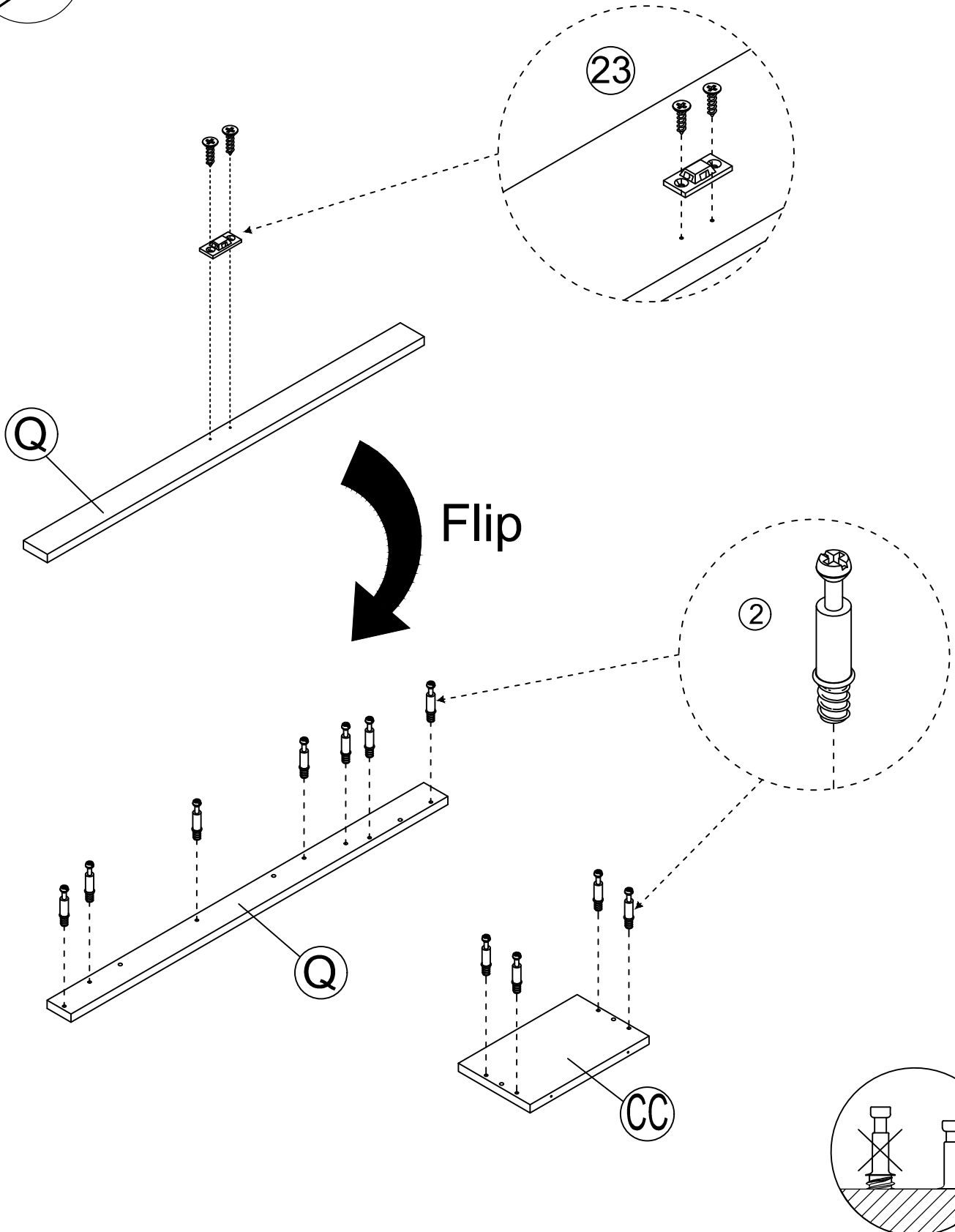
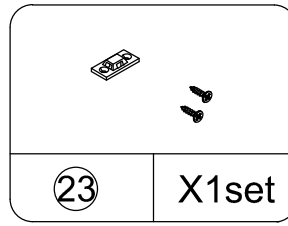
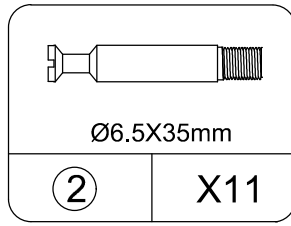
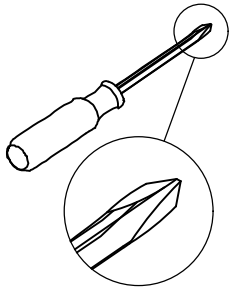

# STEP17

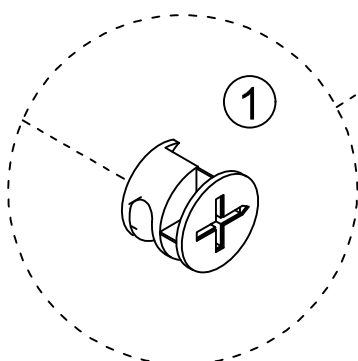
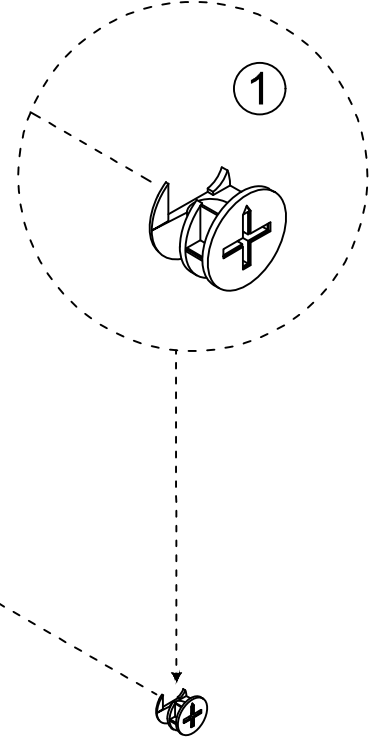
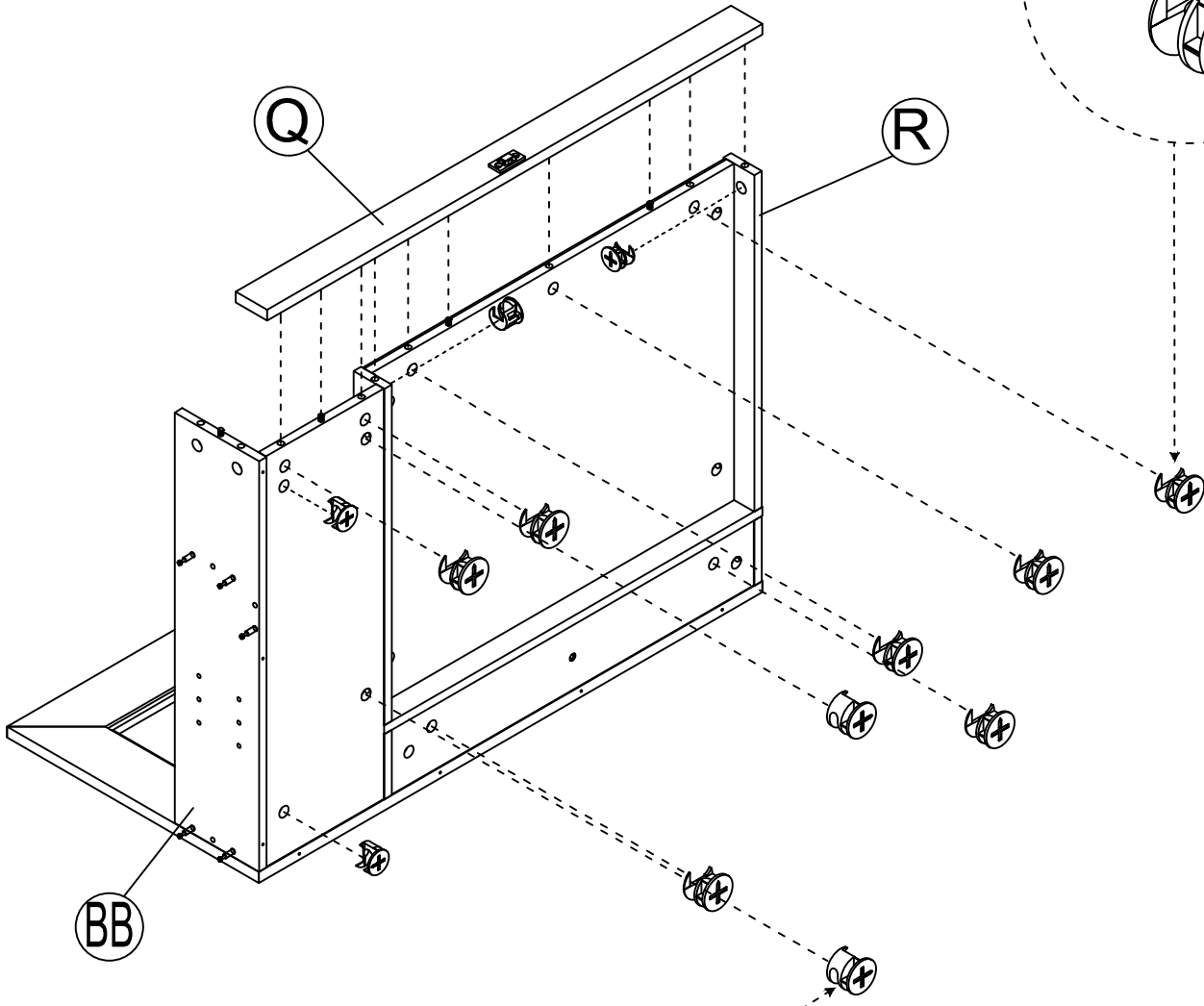
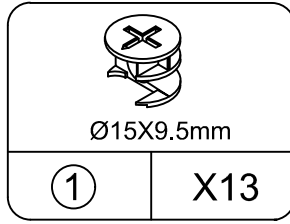
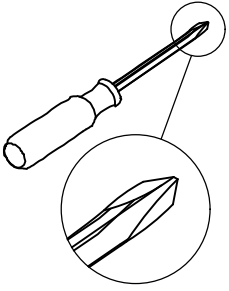

Insert the cam bolt into the hole first, then insert the cam lock and lock it.

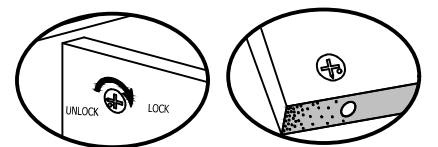

# STEP18

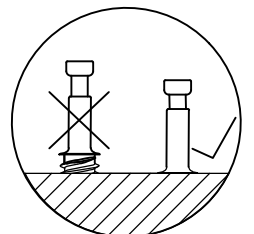
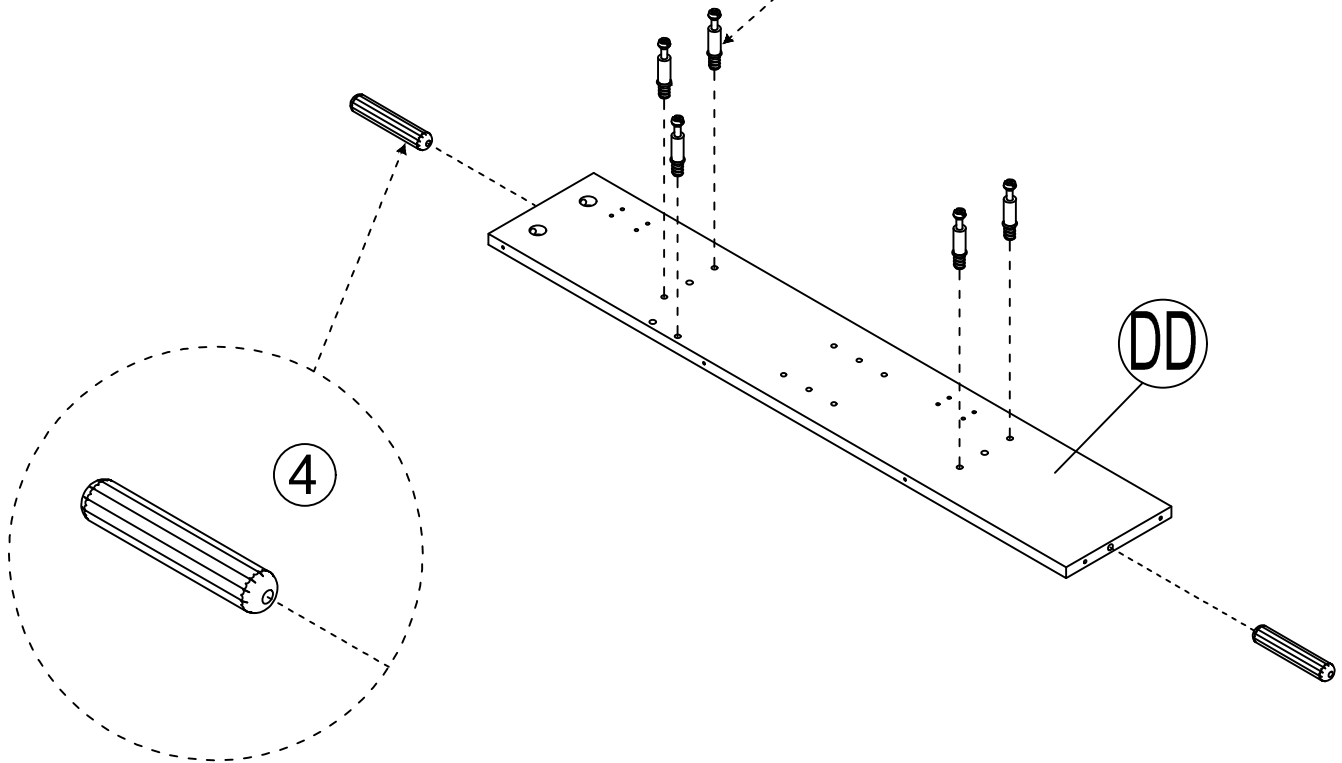
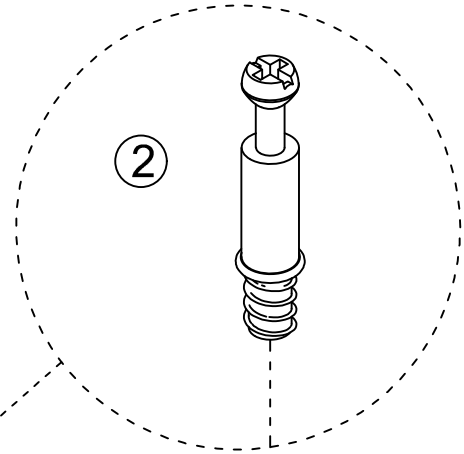
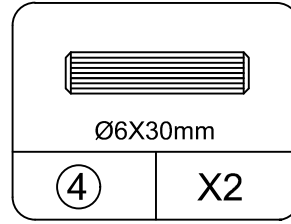
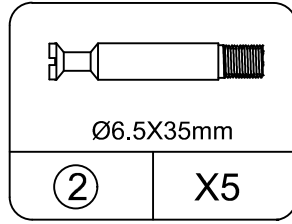
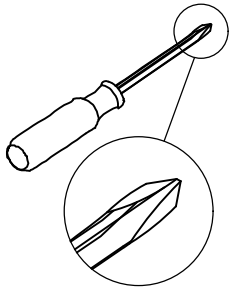

# STEP19

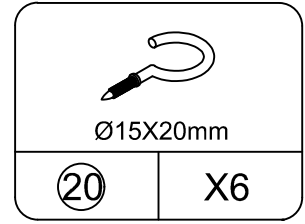
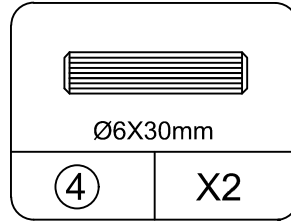
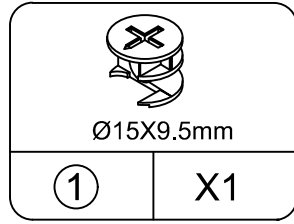
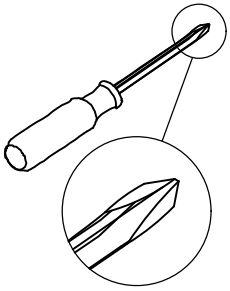

## WITHOUT EDGE BANDING

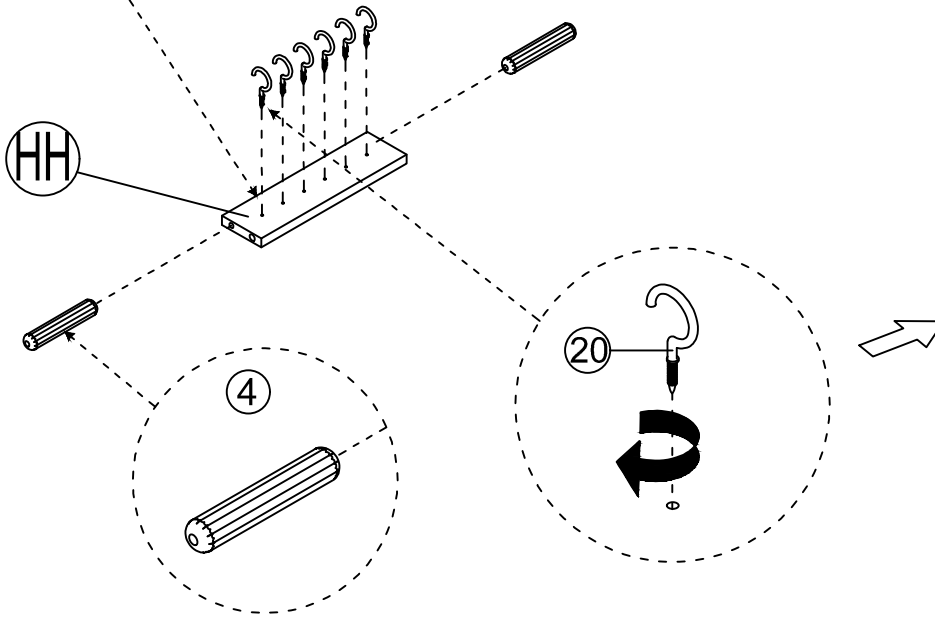

## THE RIGHT DIRECTION

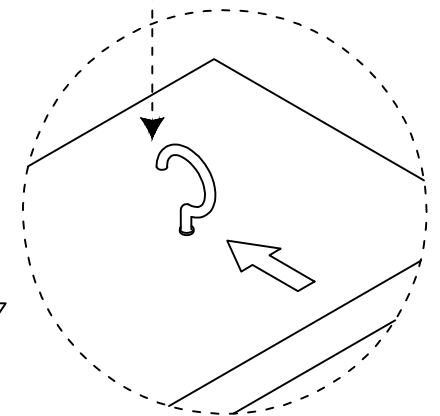

## FINISH

No. 24 hardware completion direction

## WITHOUT EDGE BANDING

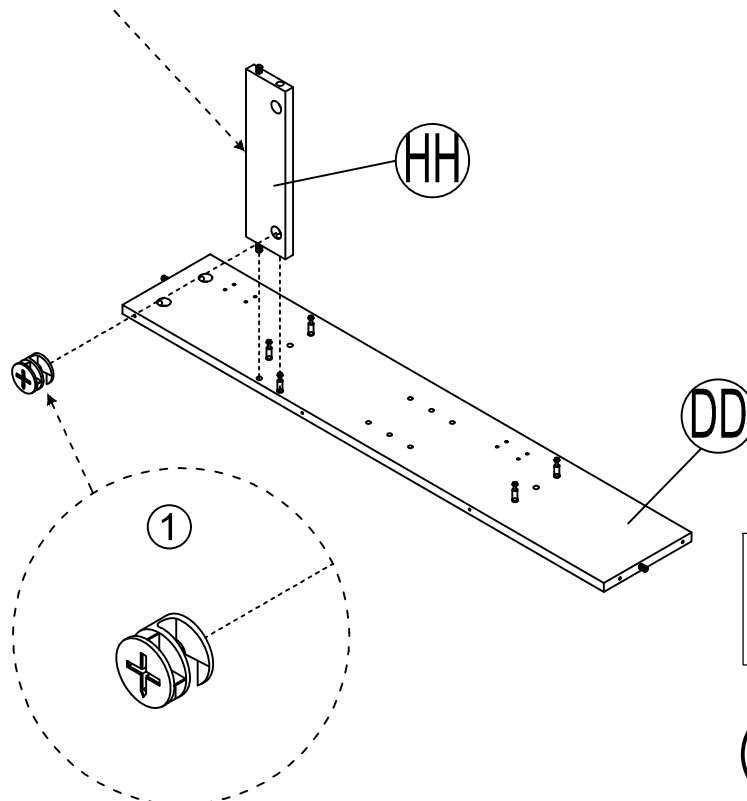

Insert the cam bolt into the hole first, then insert the cam lock and lock it.

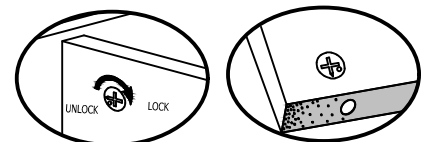

Proper orientation of CAM LOCK

# STEP20

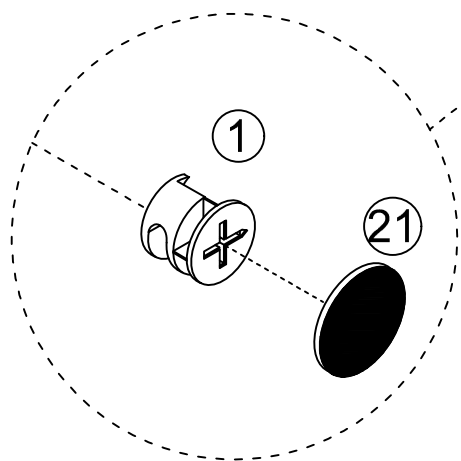
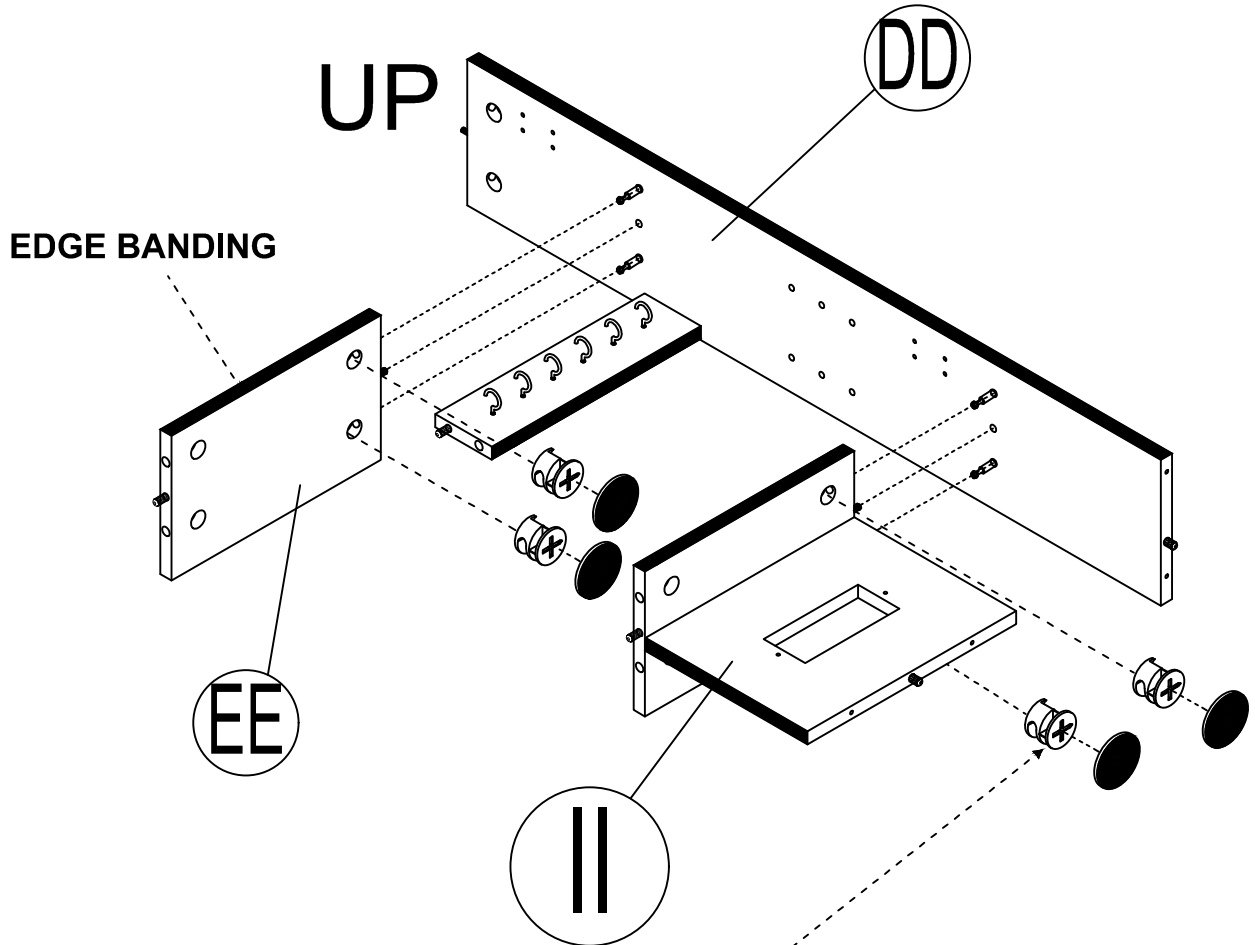
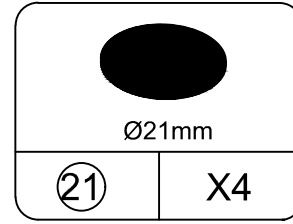
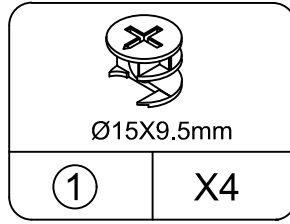
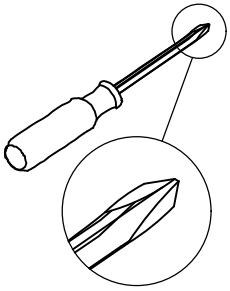

Insert the cam bolt into the hole first, then insert the cam lock and lock it.

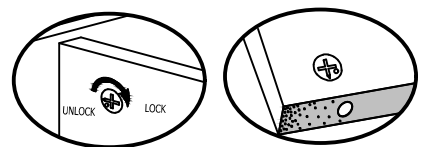

# STEP21

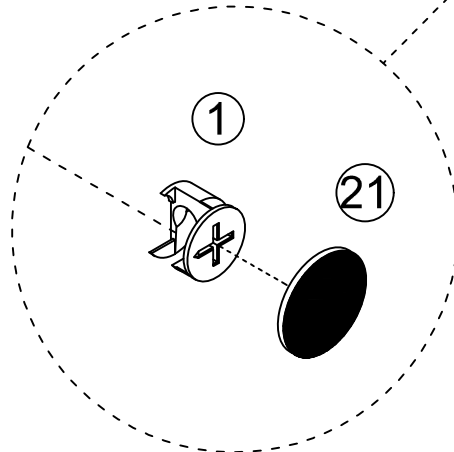
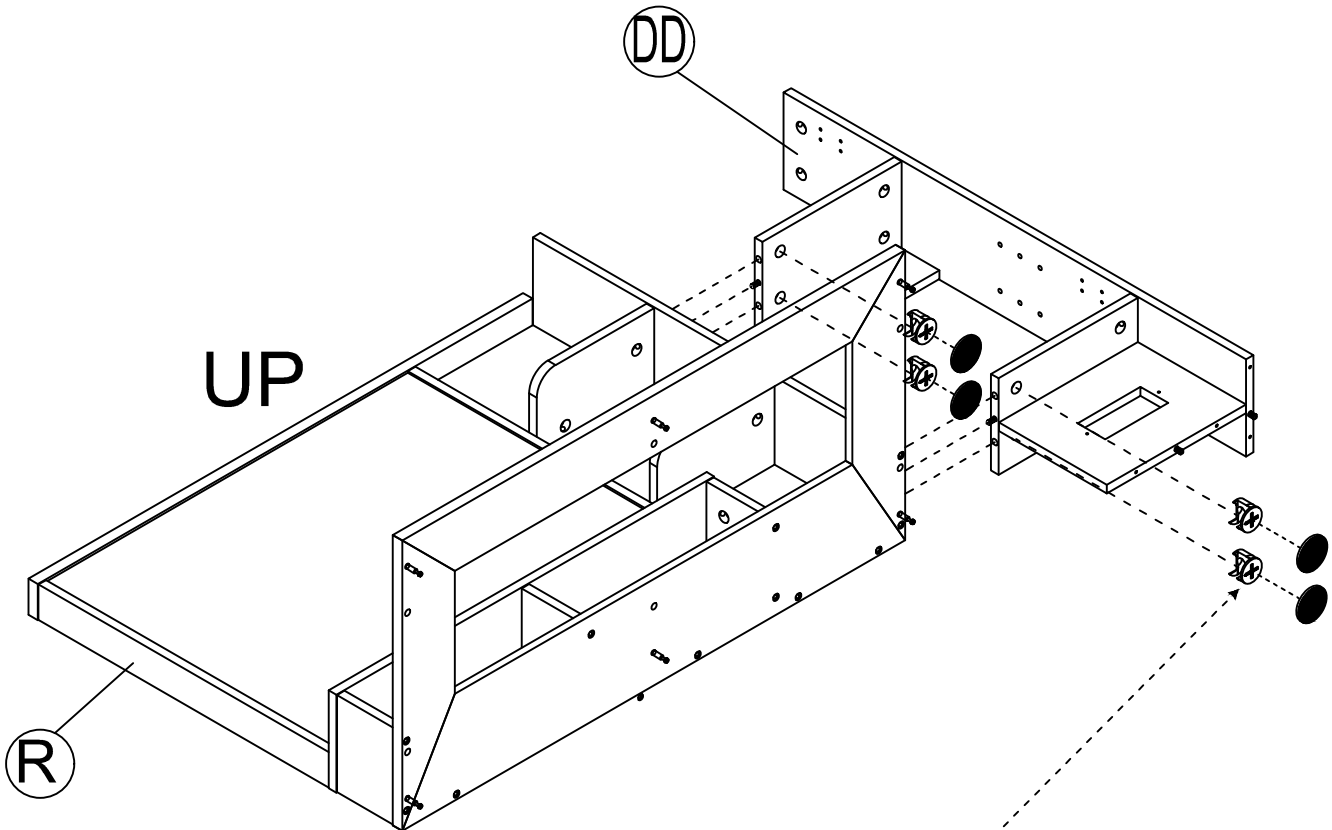
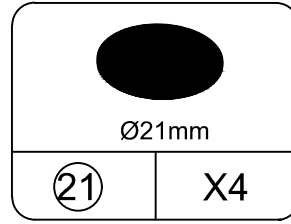
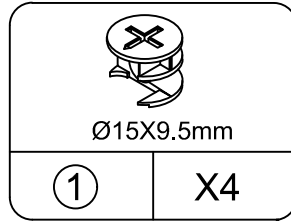
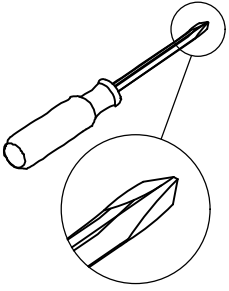

Insert the cam bolt into the hole first, then insert the cam lock and lock it.

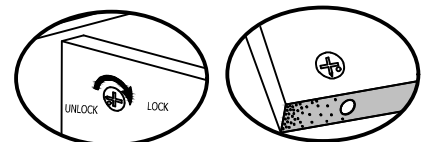

Proper orientation of CAM LOCK



# STEP22

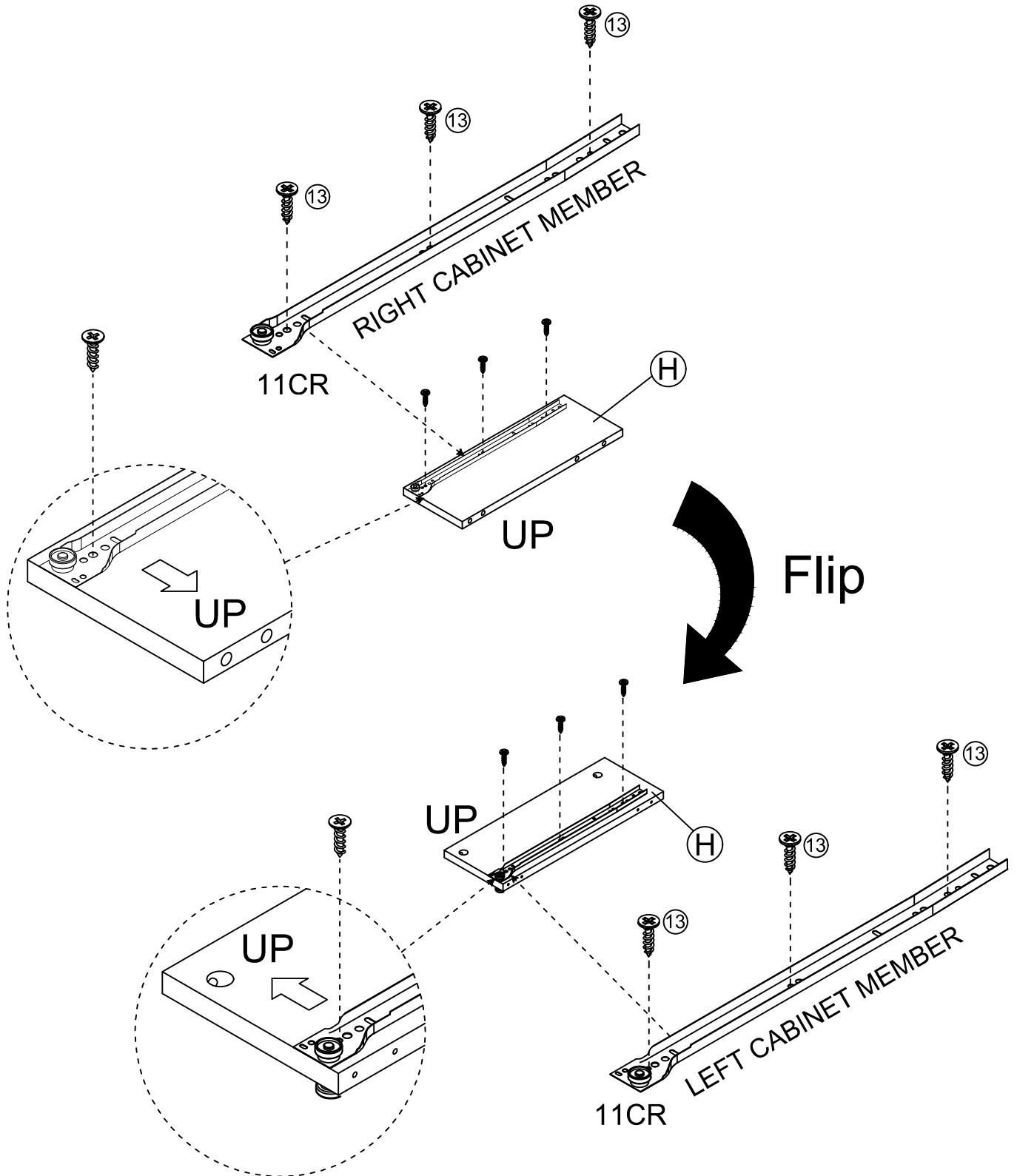
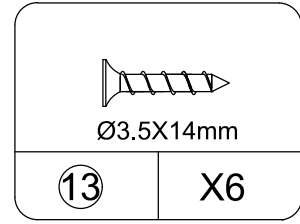
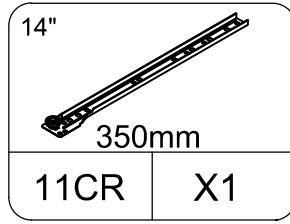
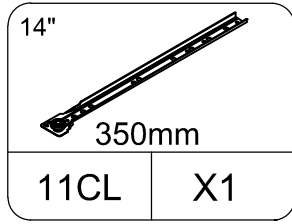
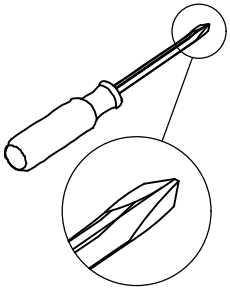

# STEP 23

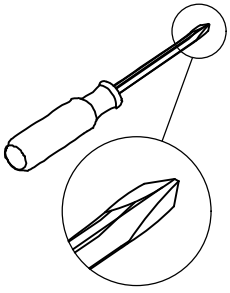

 Ø8X30mm	
③	X2

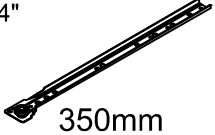
14"  350mm	
11CL	X1

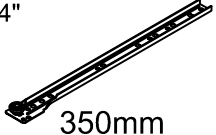
14"  350mm	
11CR	X1

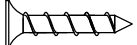
 Ø3.5X14mm	
⑬	X6

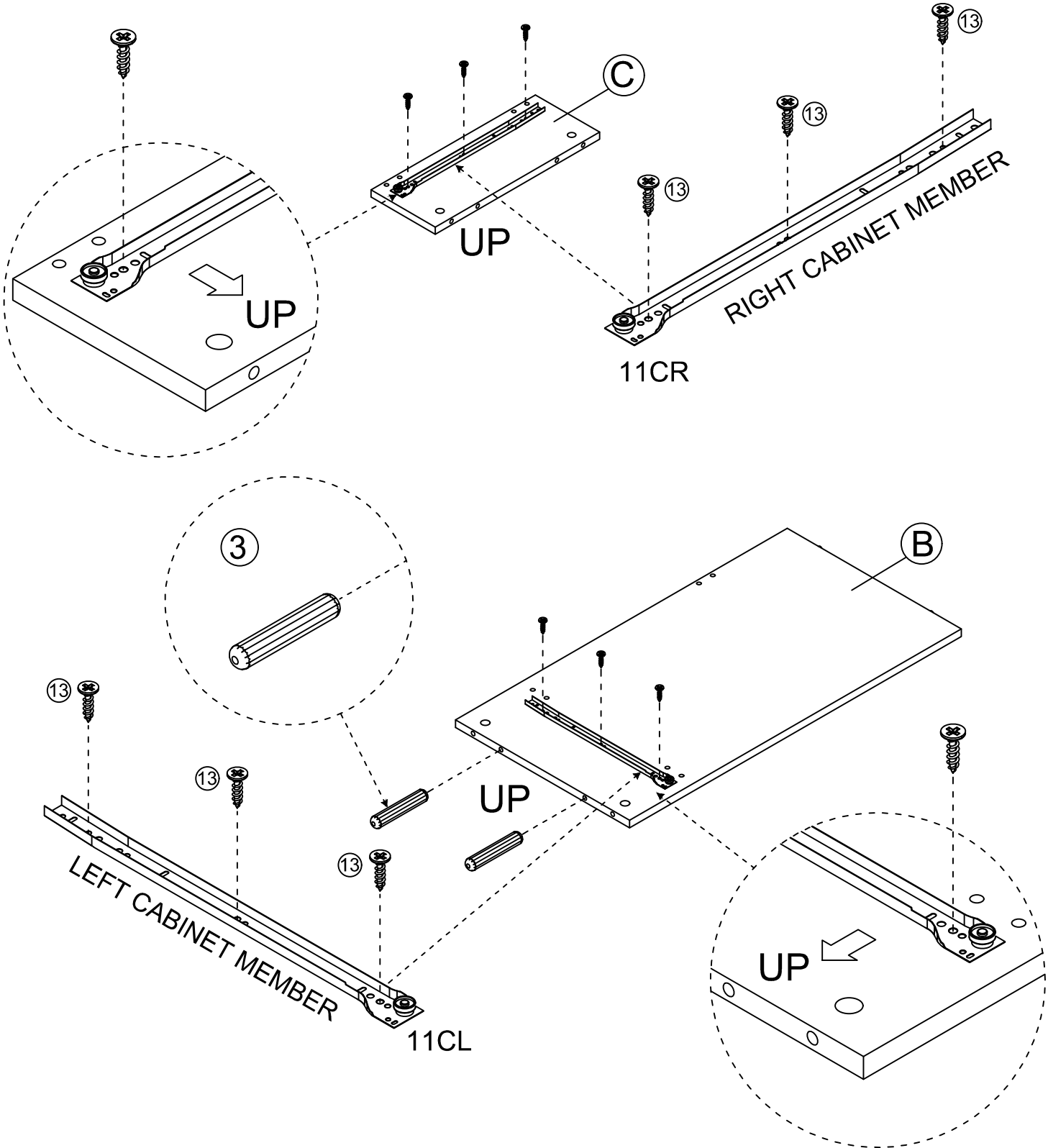

# STEP24

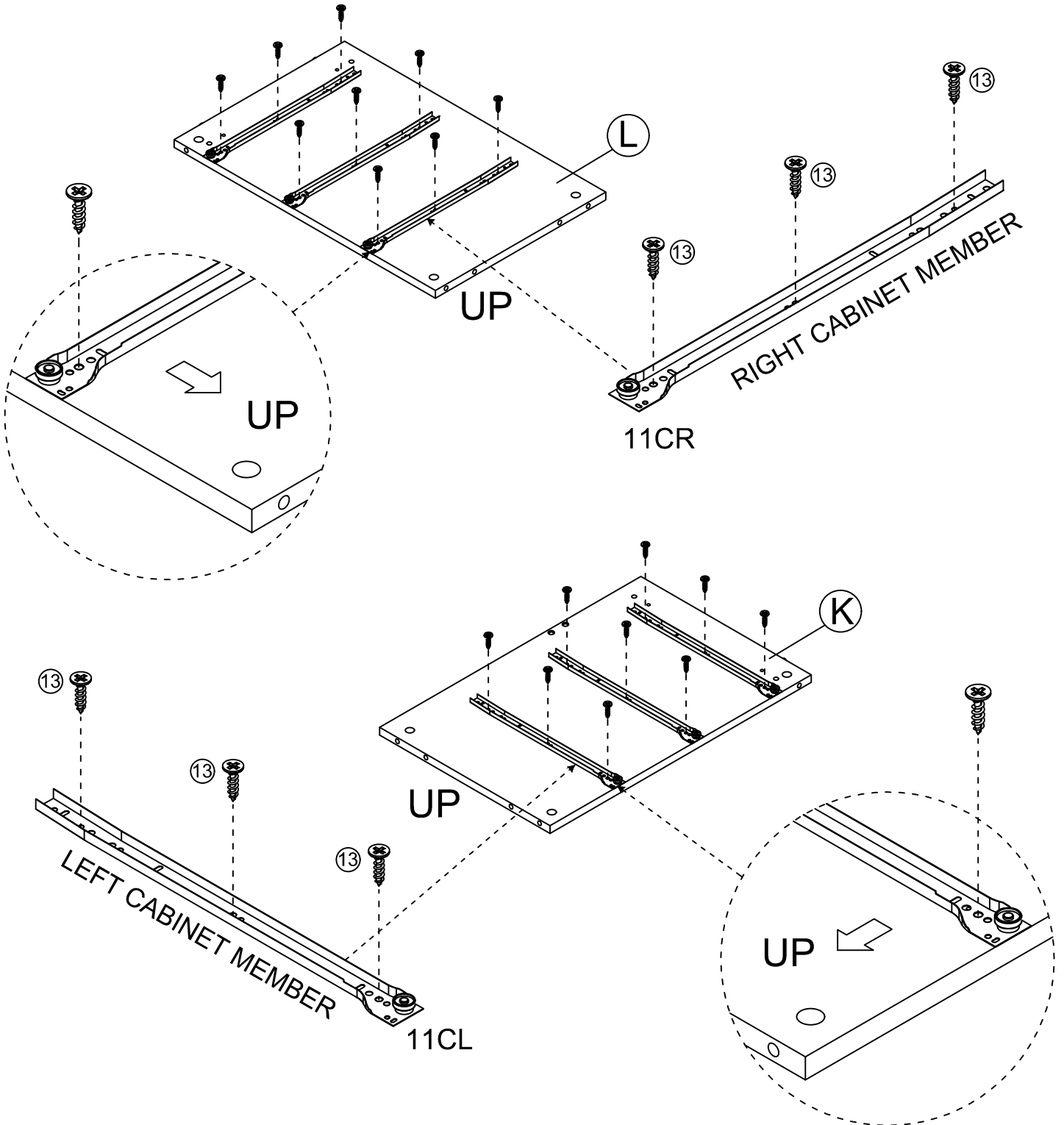
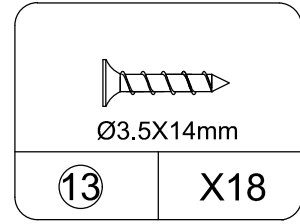
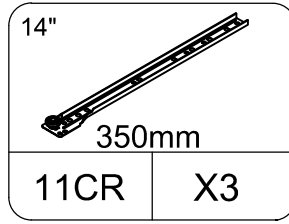
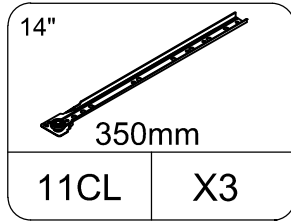
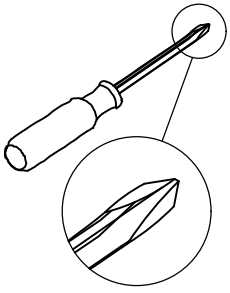

# STEP25

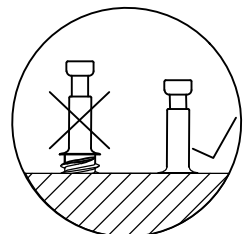
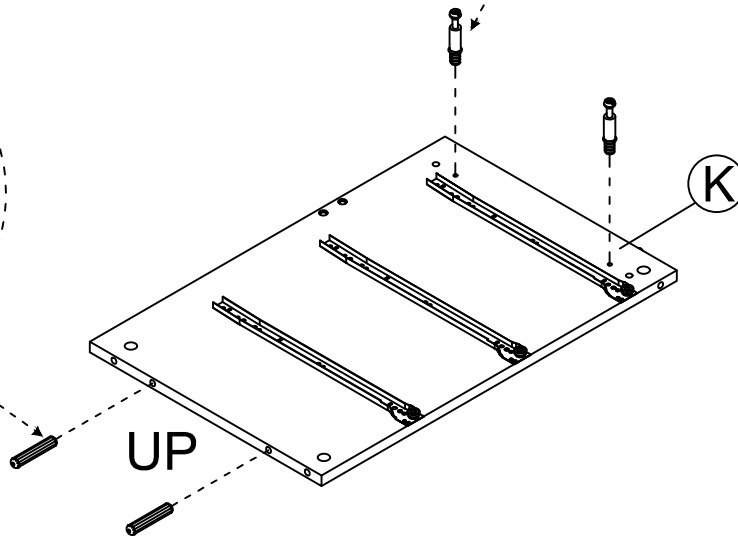
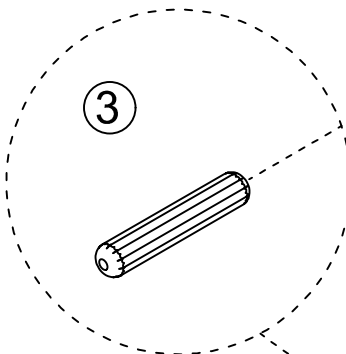
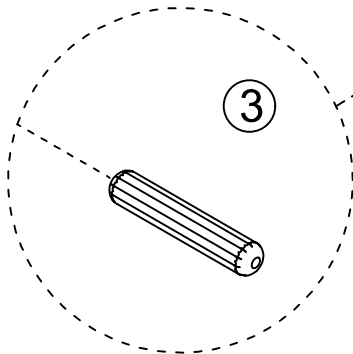
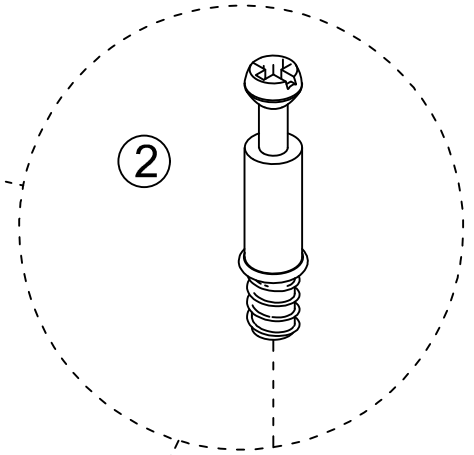
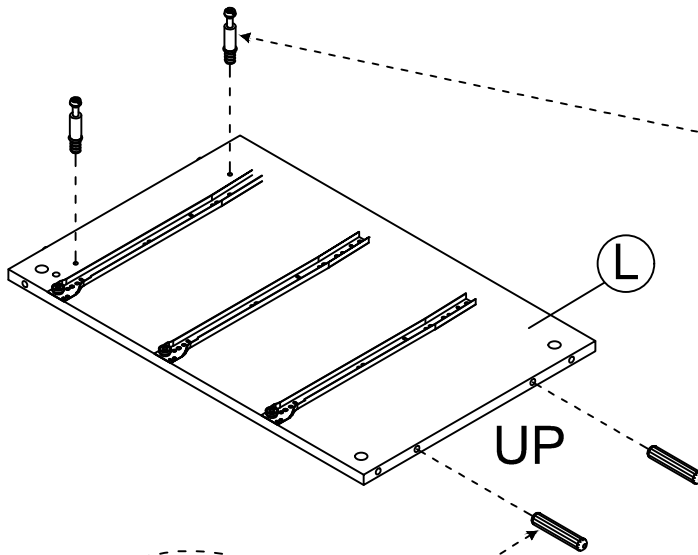
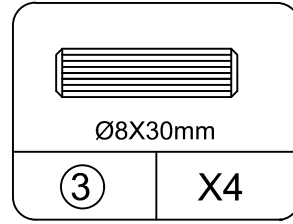
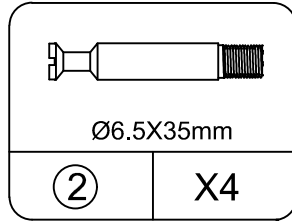
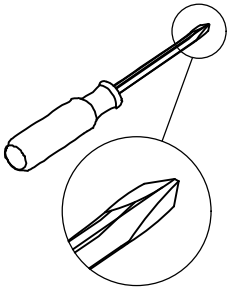

# STEP26

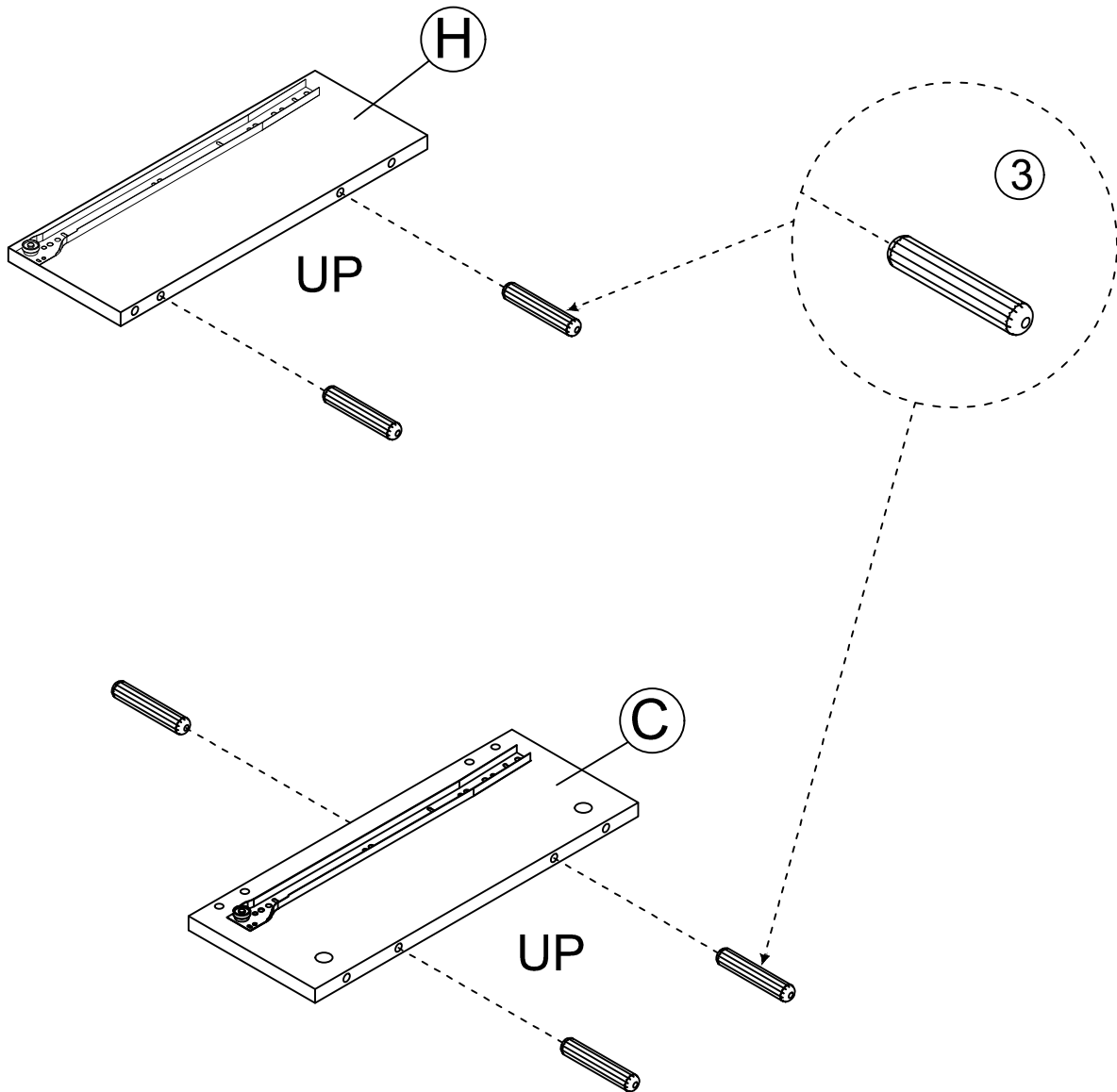
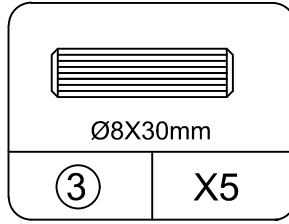
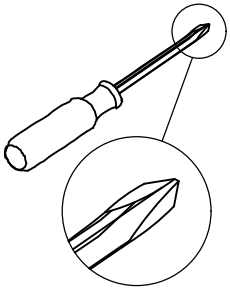

# STEP27

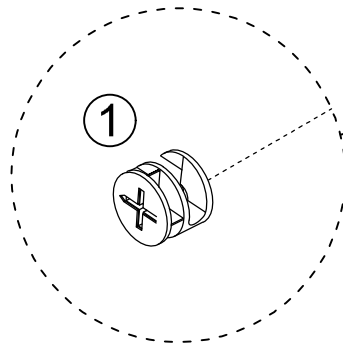
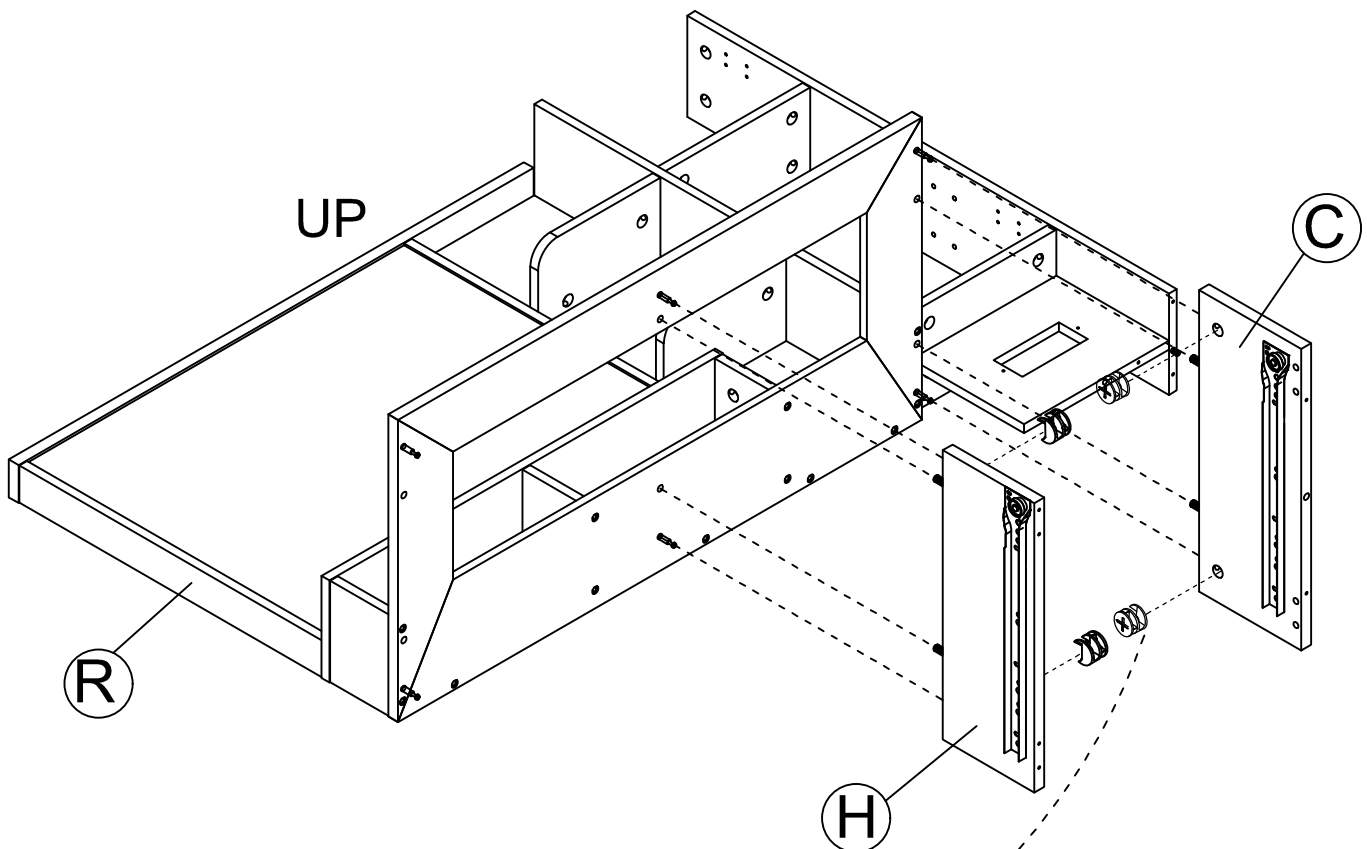
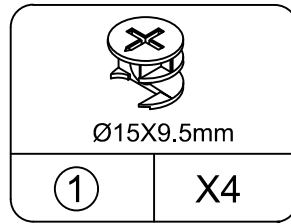
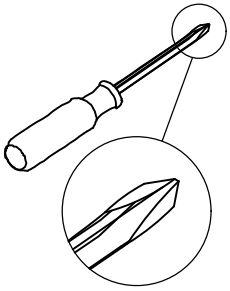

Insert the cam bolt into the hole first, then insert the cam lock and lock it.

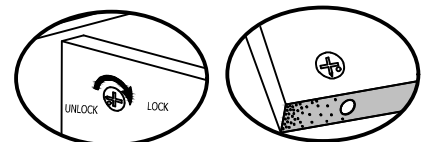

Proper orientation of CAM LOCK

# STEP28

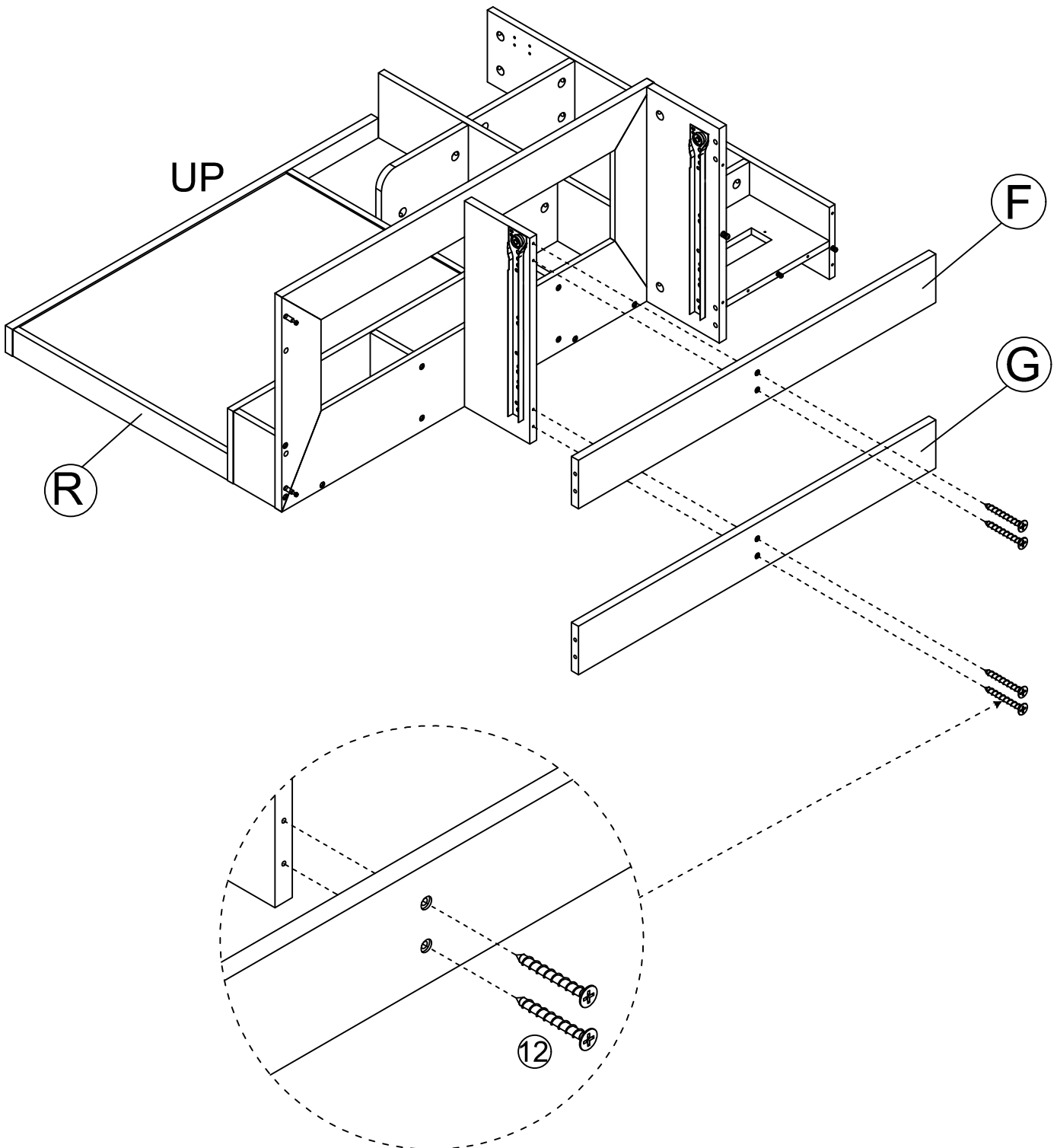
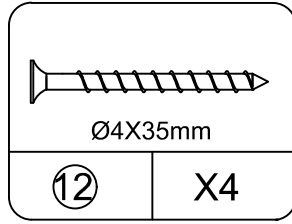
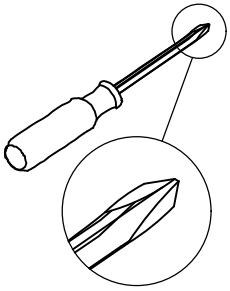

# STEP29

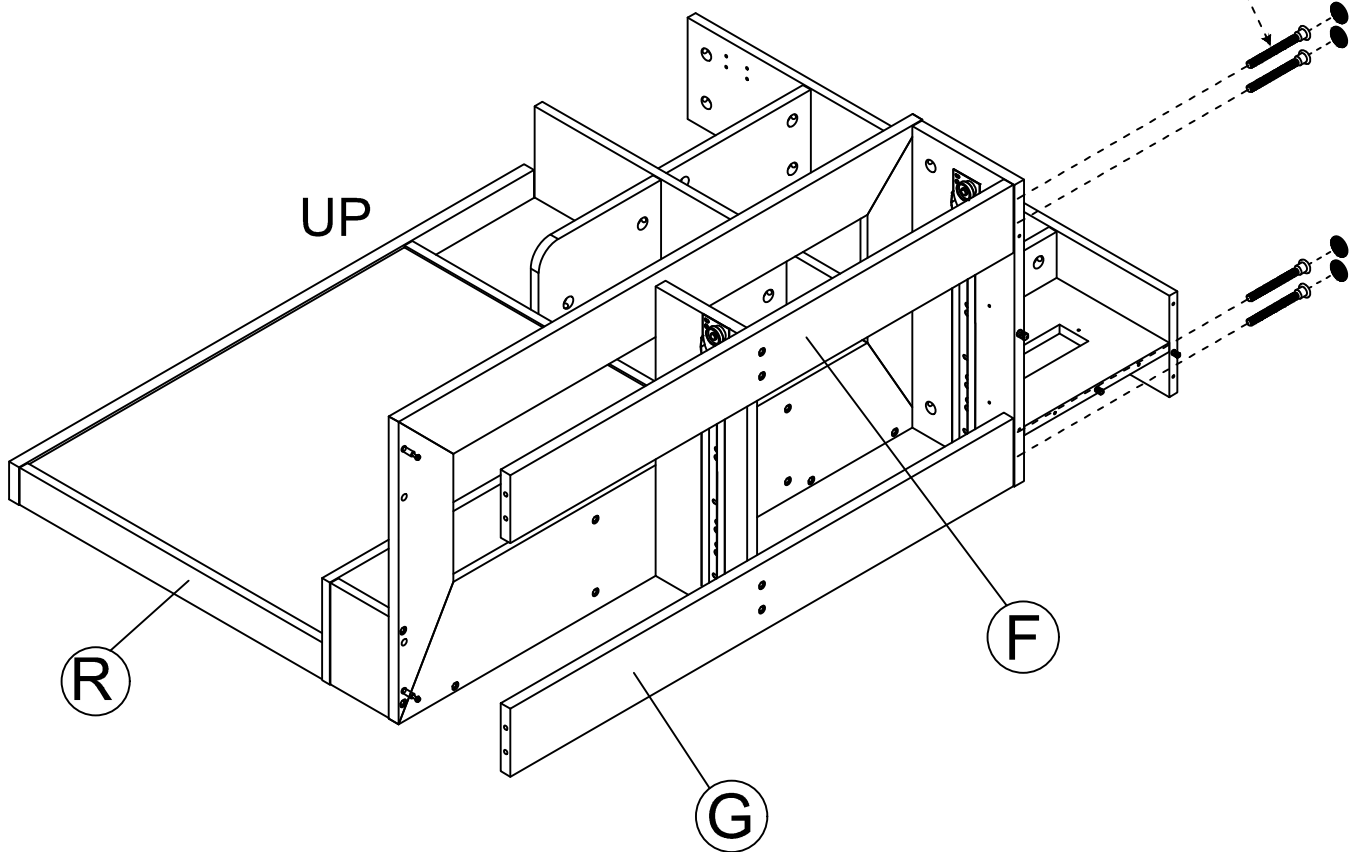
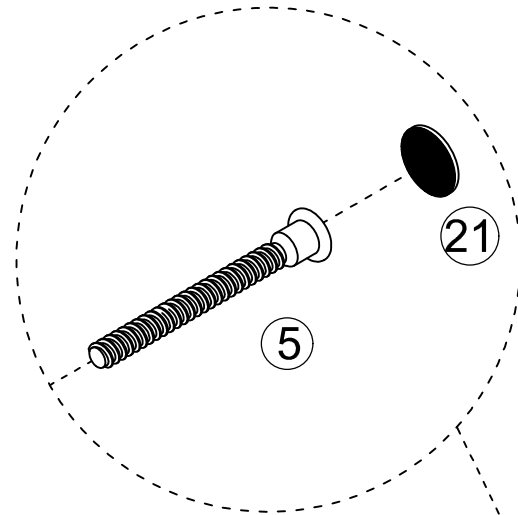
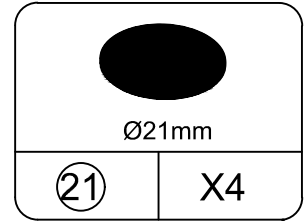
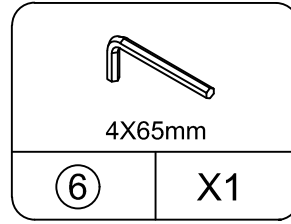
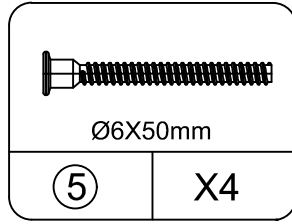
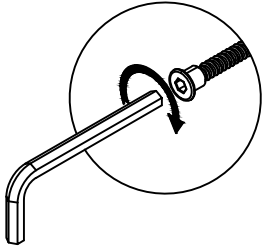



# STEP30

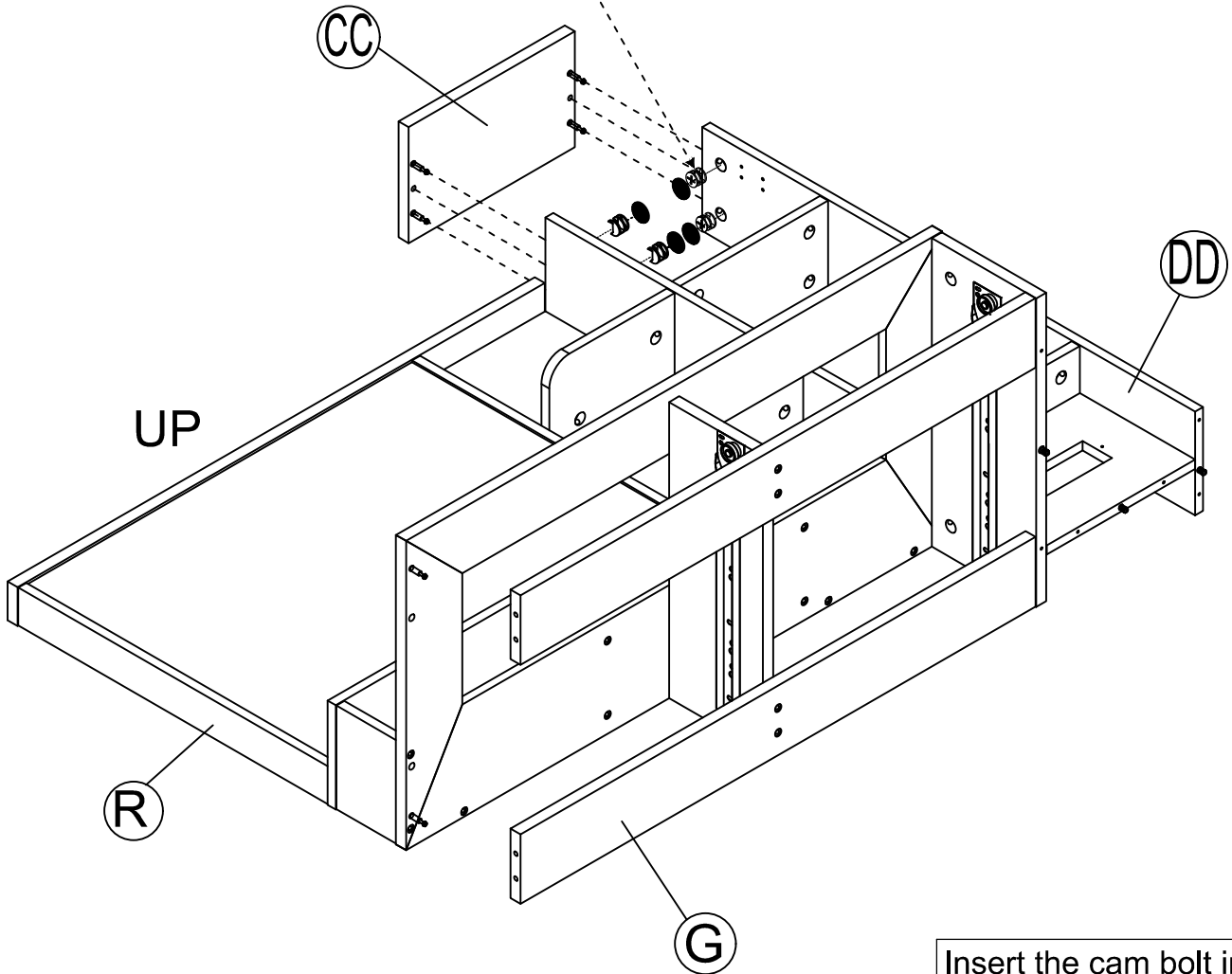
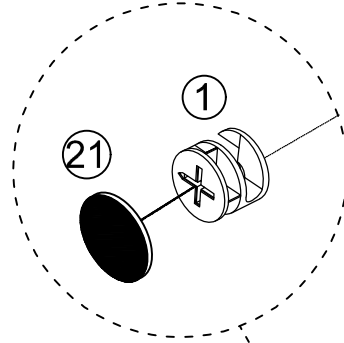
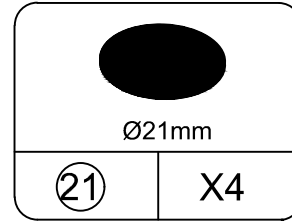
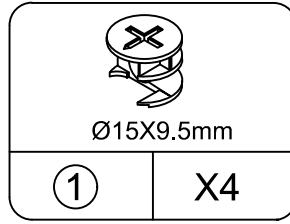
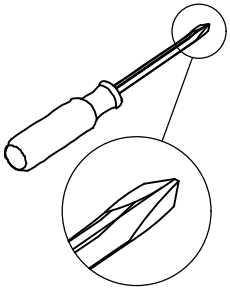

Insert the cam bolt into the hole first, then insert the cam lock and lock it.

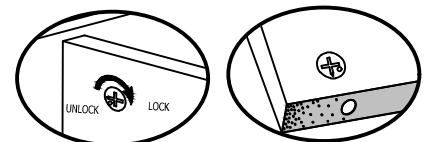

Proper orientation of CAM LOCK

# STEP31

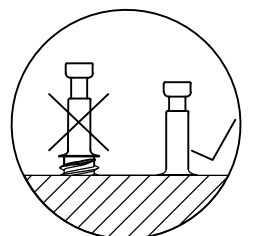
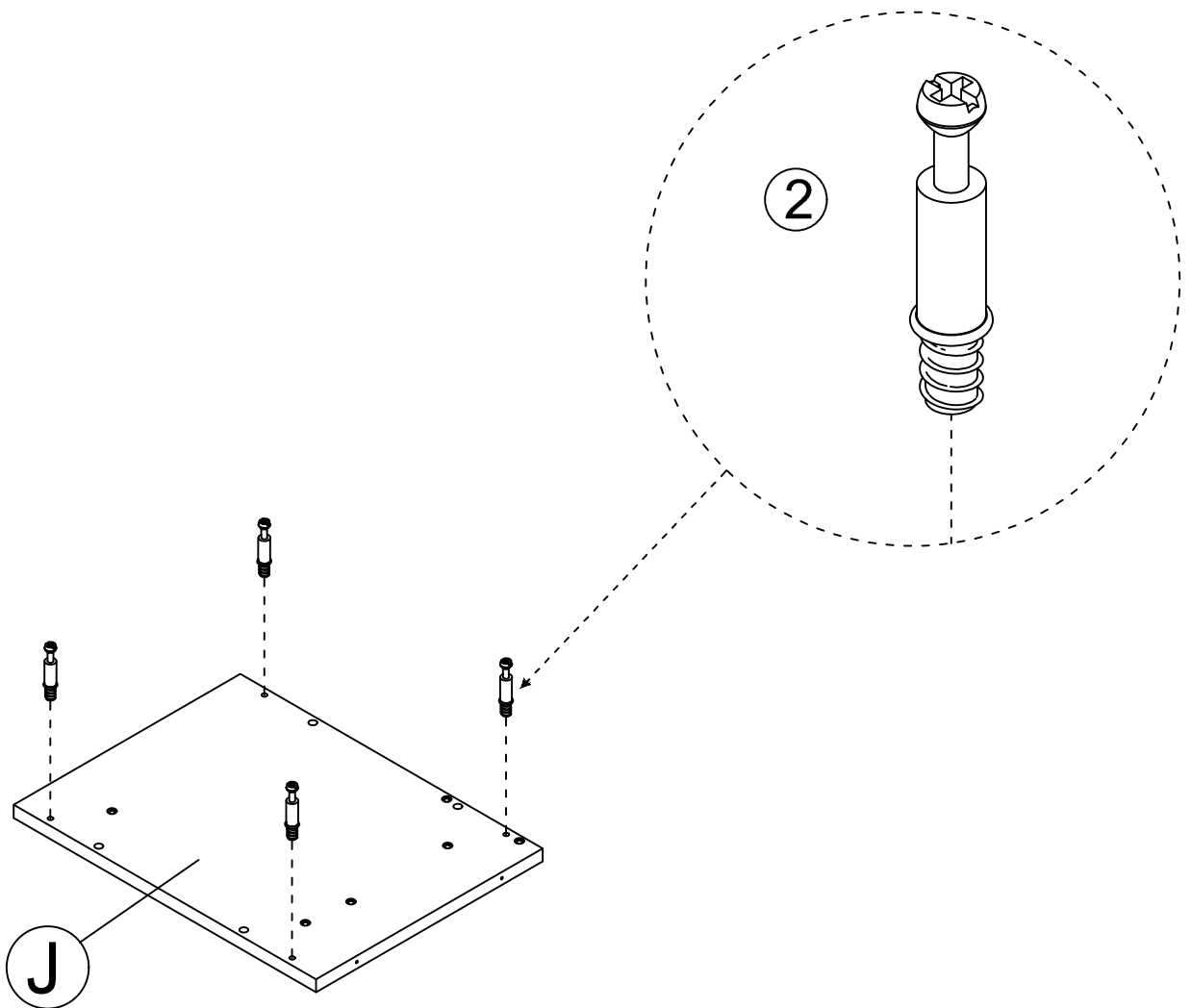
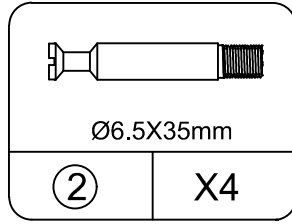
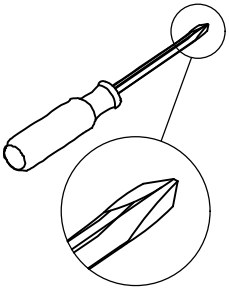

# STEP32

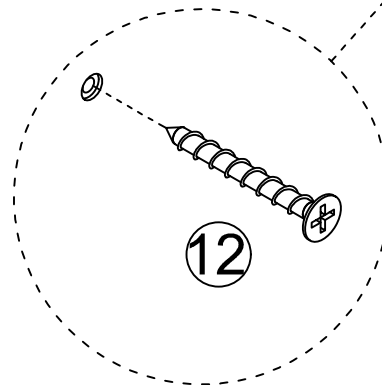
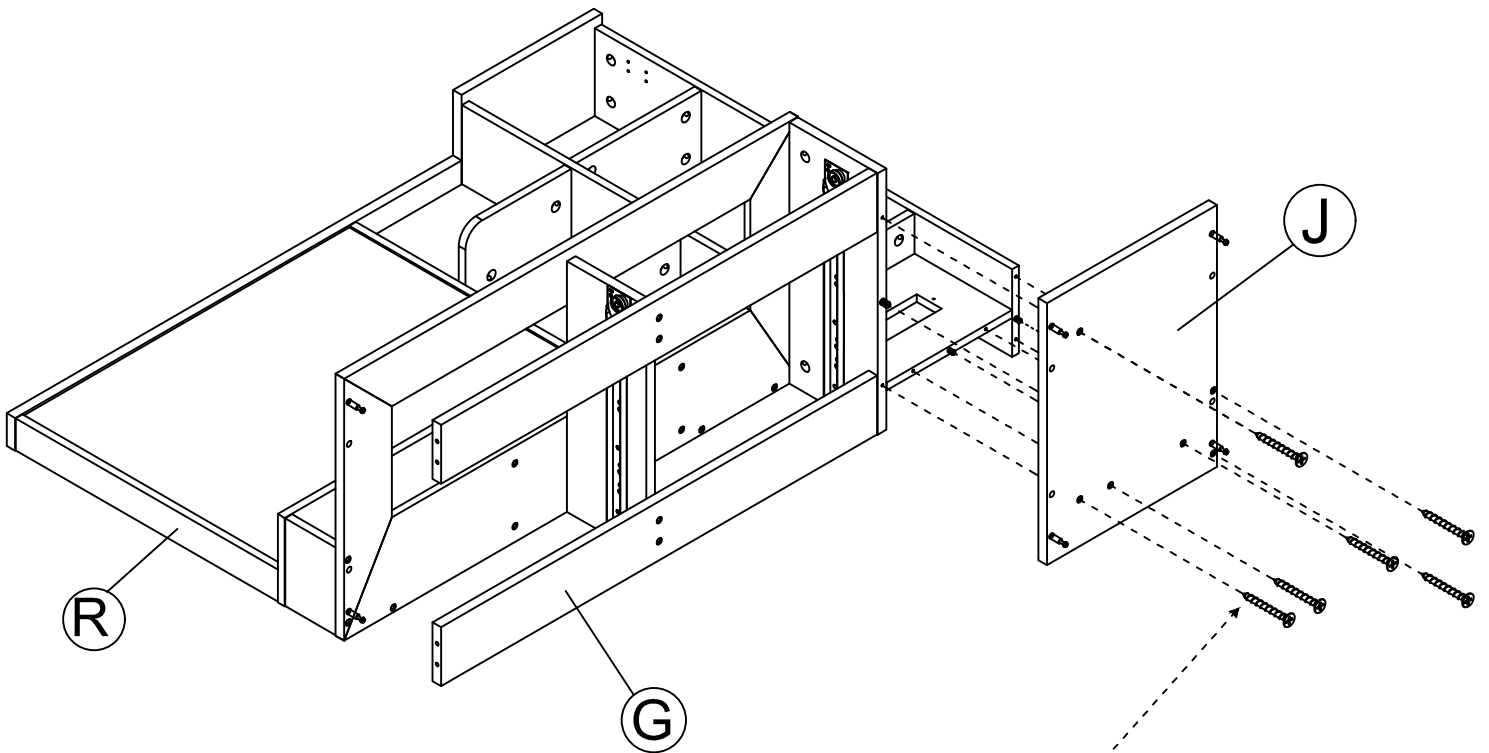
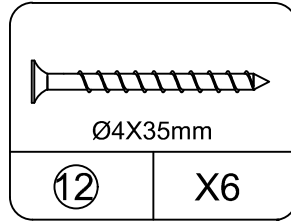
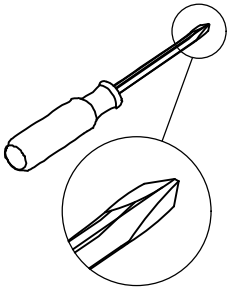

# STEP33

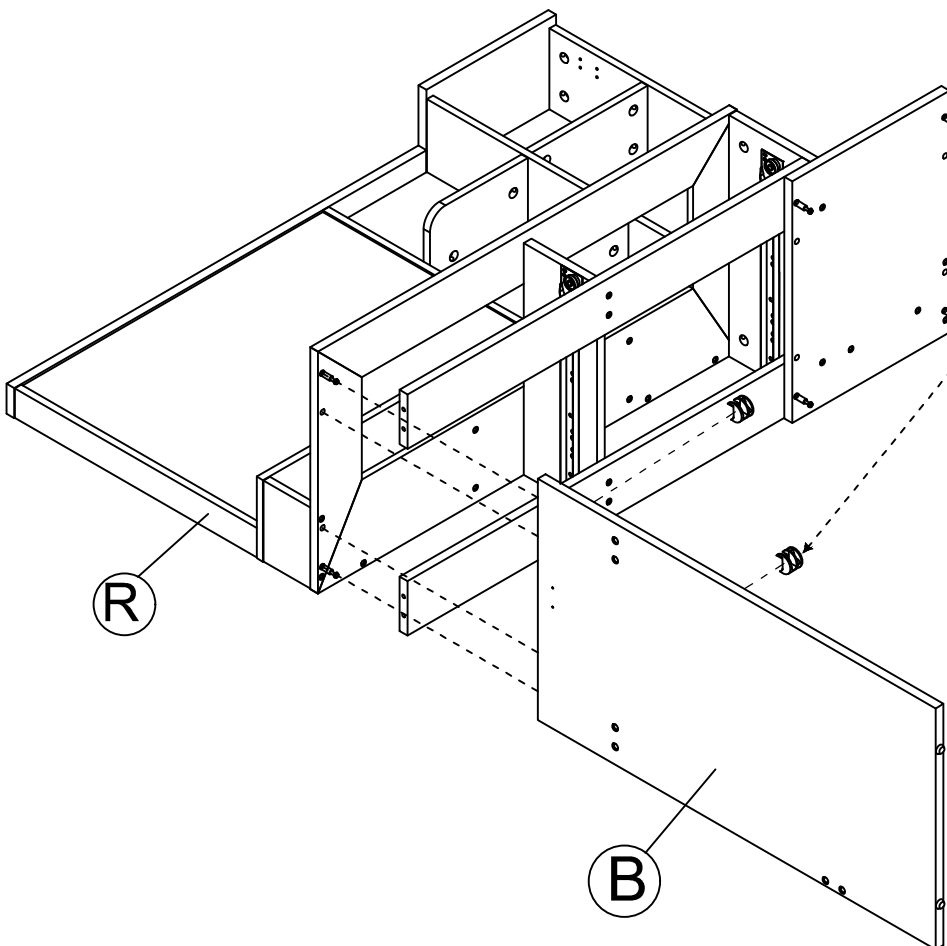
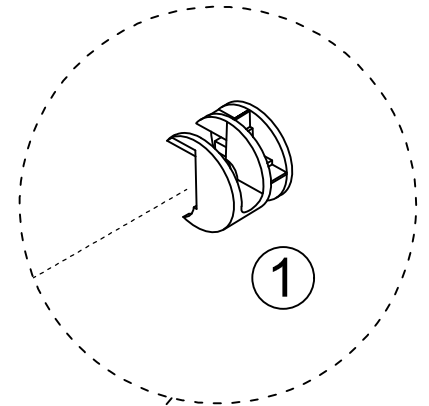
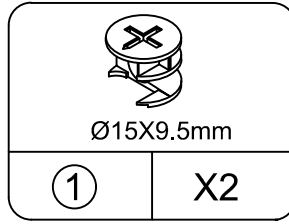
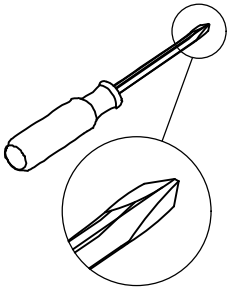

Insert the cam bolt into the hole first, then insert the cam lock and lock it.

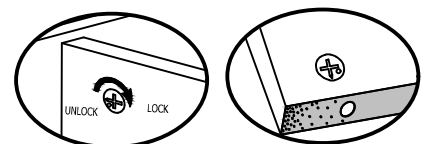

Proper orientation of CAM LOCK

# STEP34

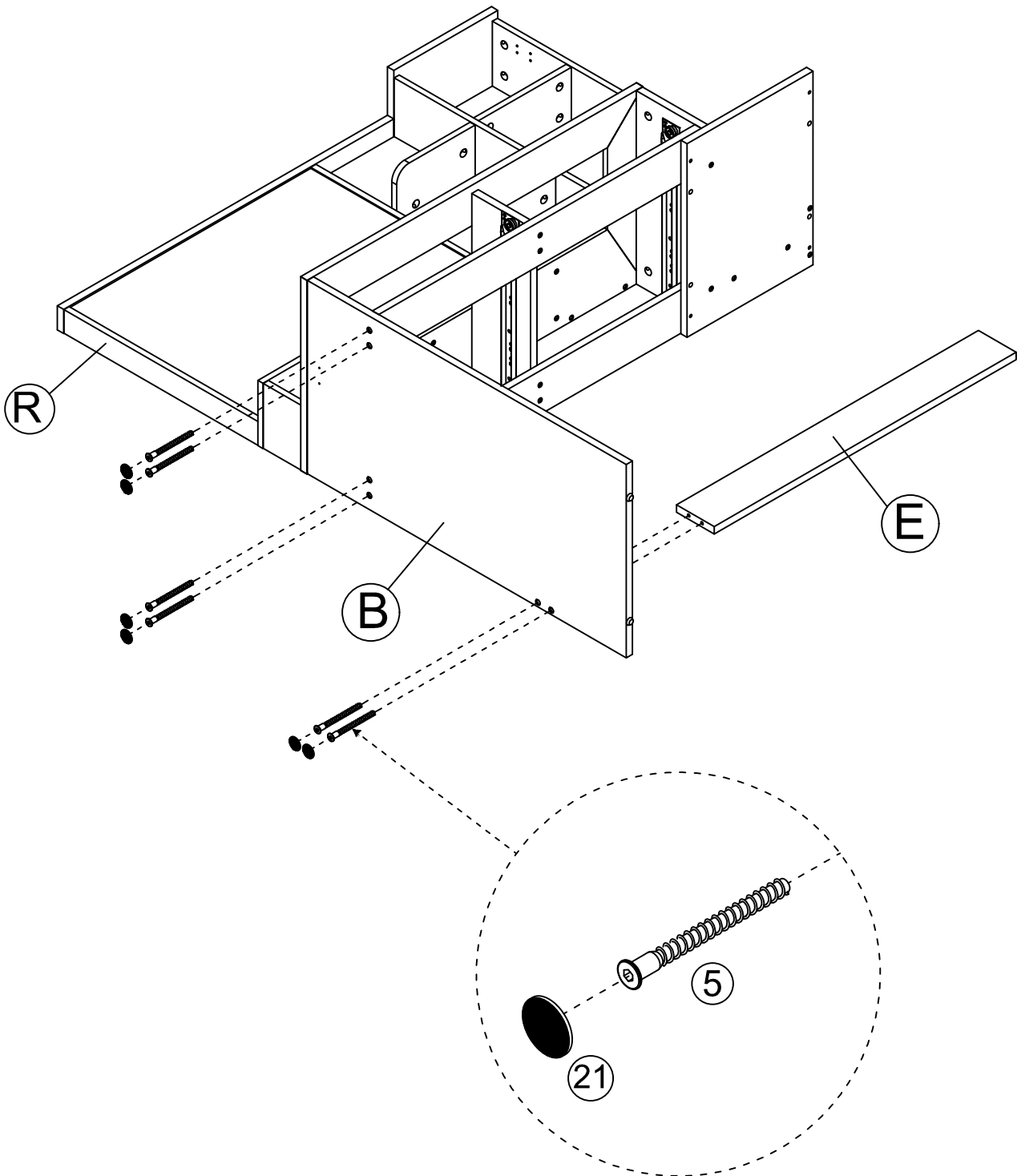
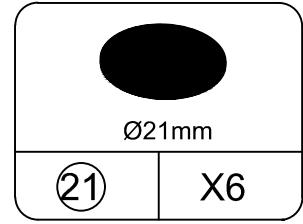
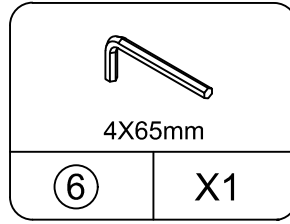
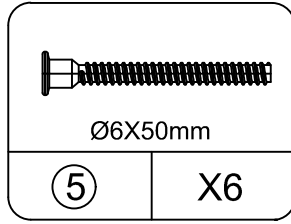
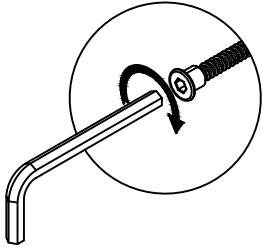

# STEP35

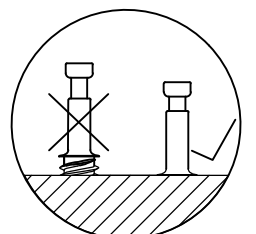
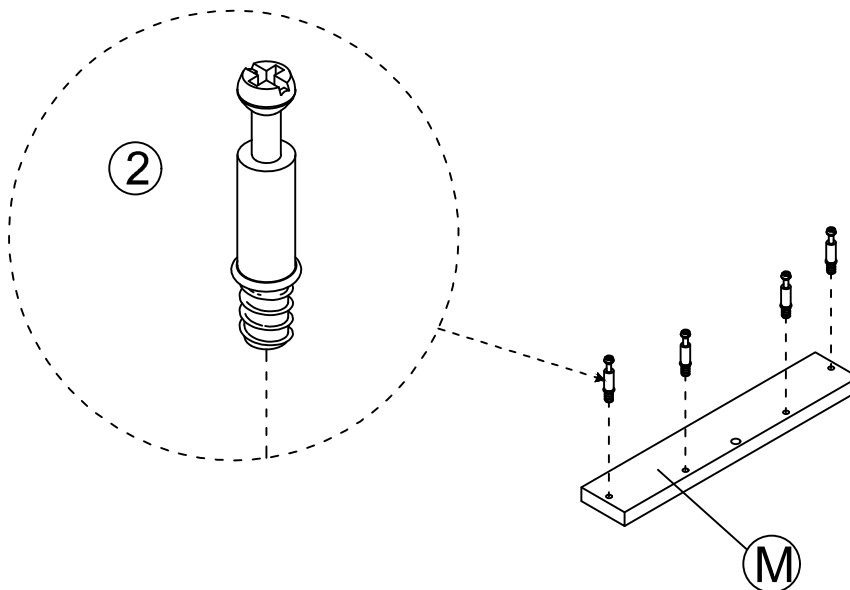
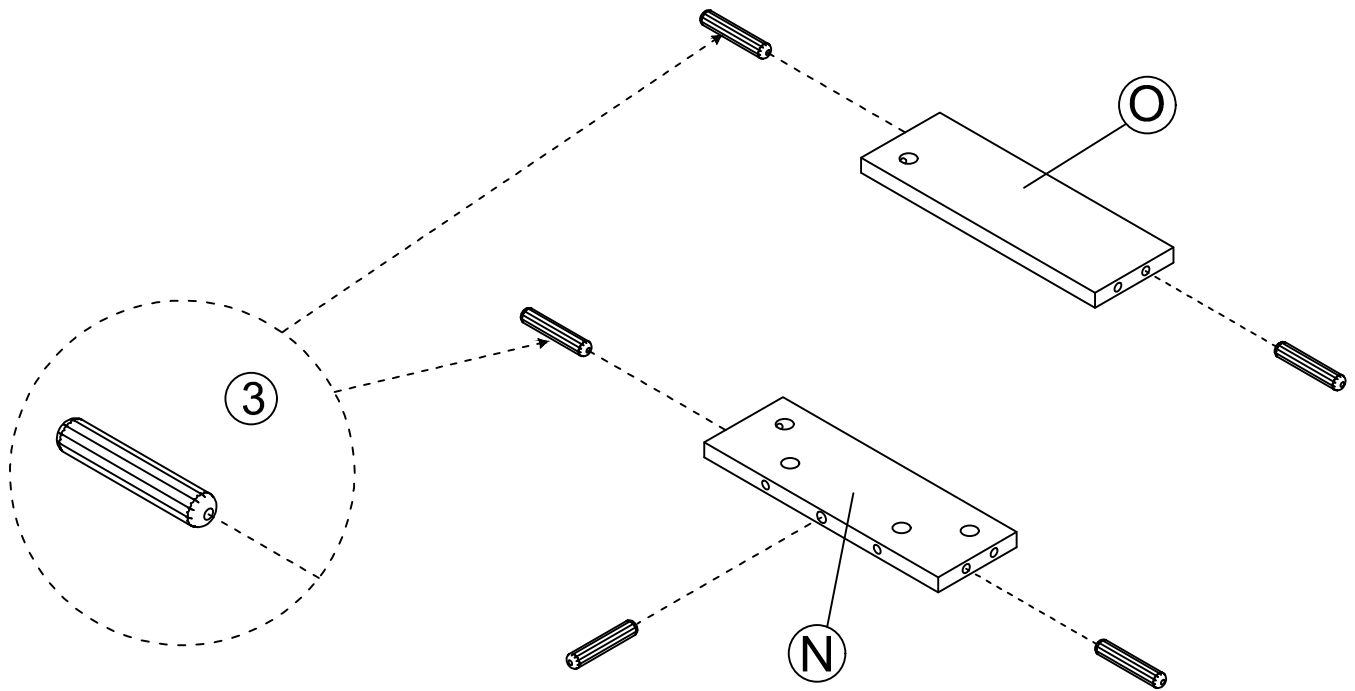
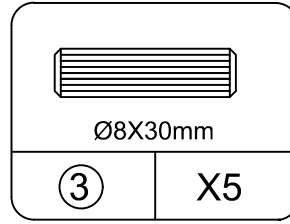
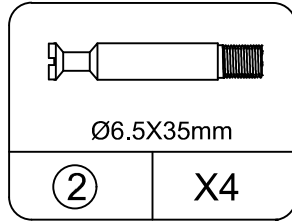
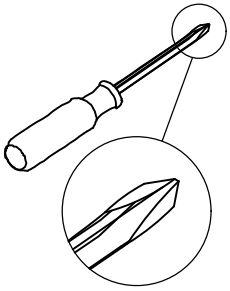

# STEP36

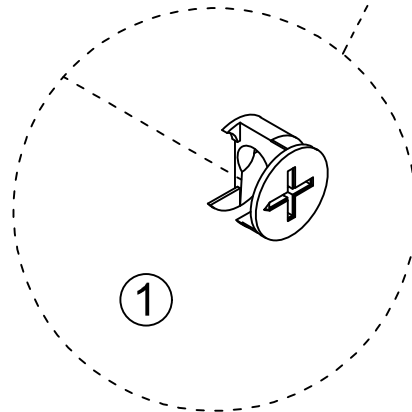
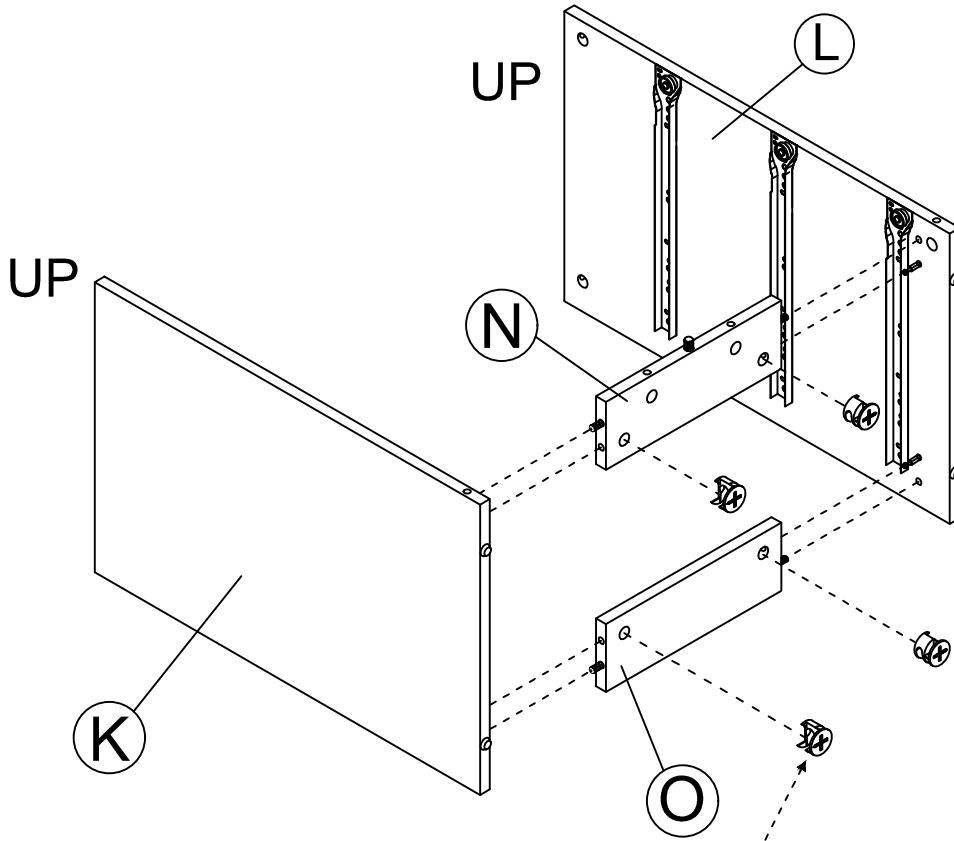
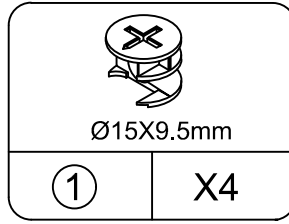
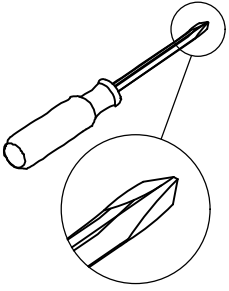

Insert the cam bolt into the hole first, then insert the cam lock and lock it.

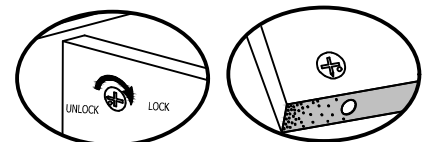

Proper orientation of CAM LOCK

# STEP37

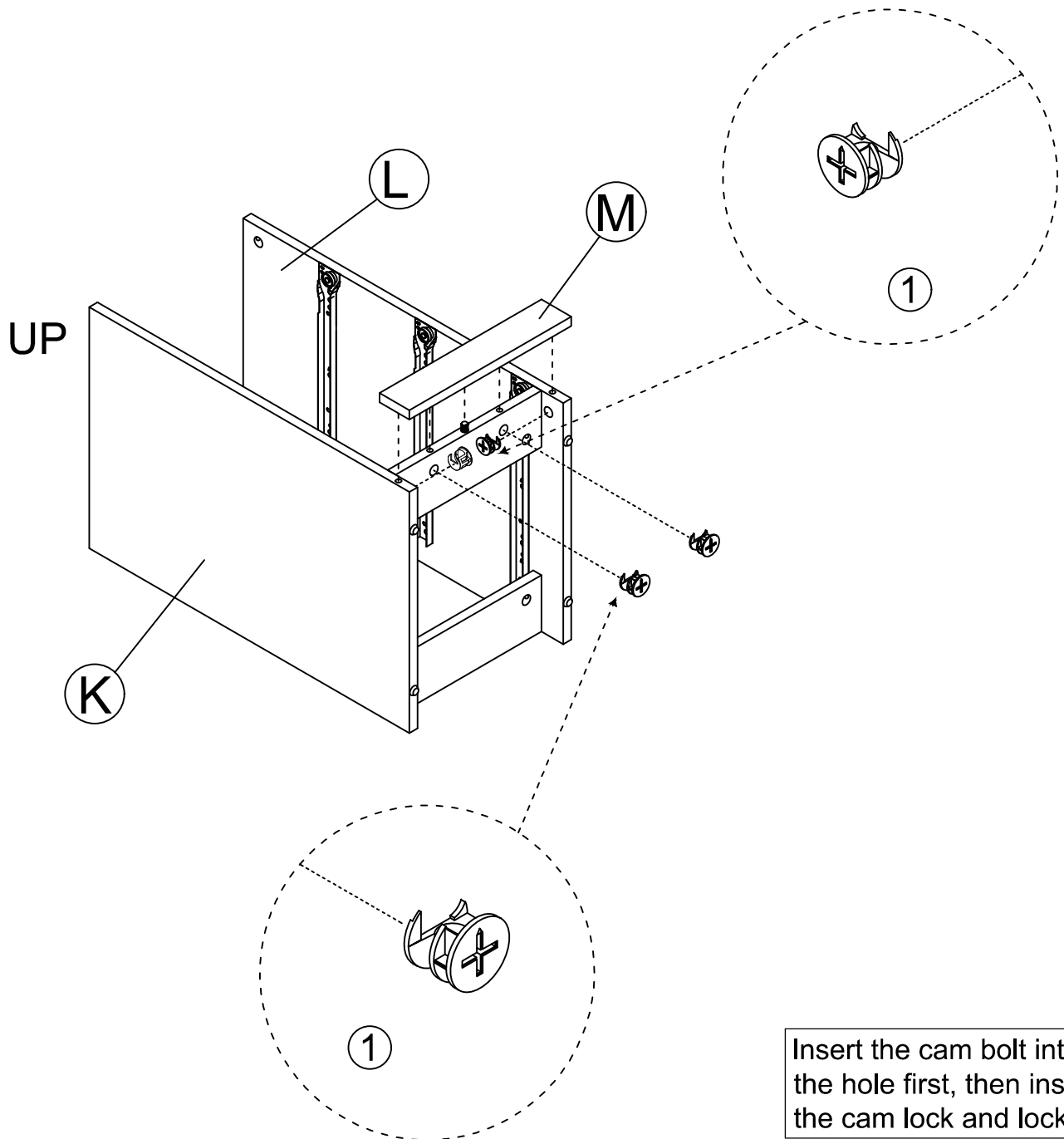
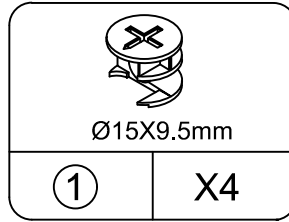
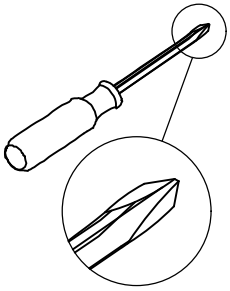

Insert the cam bolt into the hole first, then insert the cam lock and lock it.

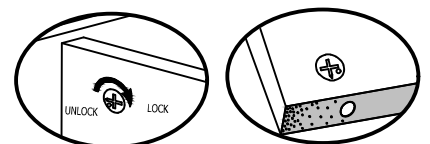

Proper orientation of CAM LOCK



# STEP38

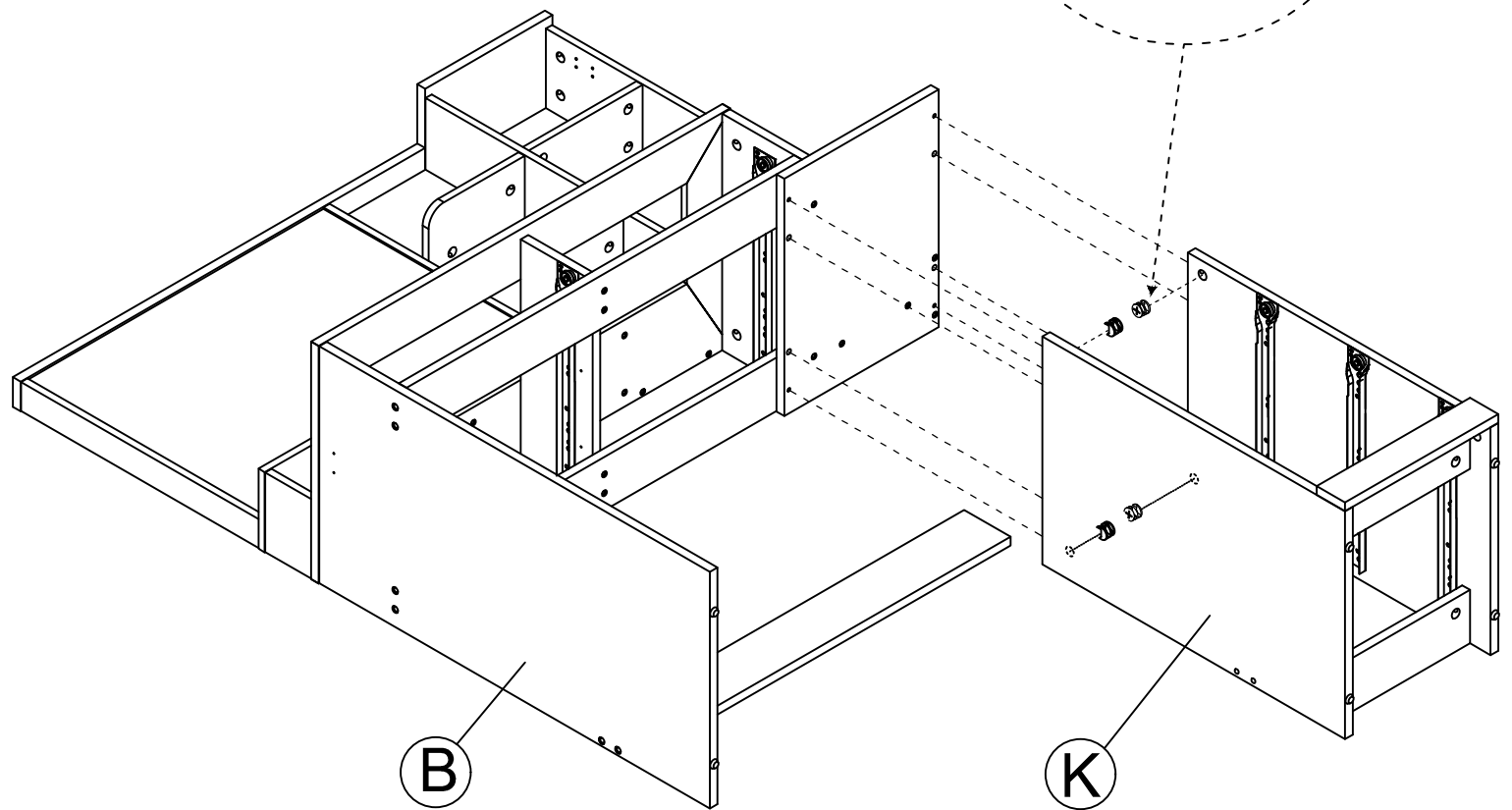
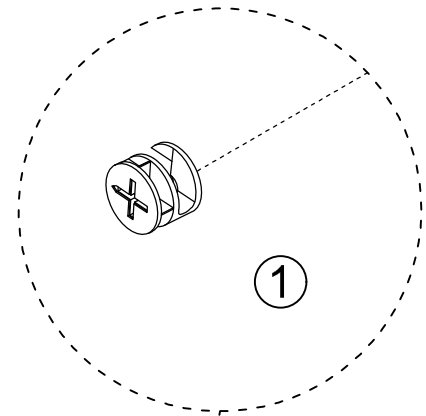
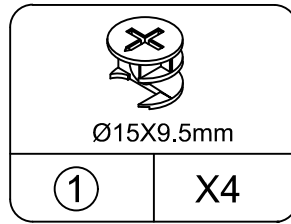
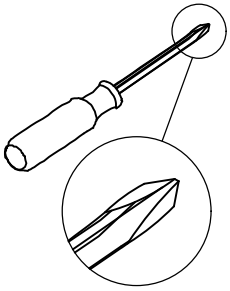

Insert the cam bolt into the hole first, then insert the cam lock and lock it.

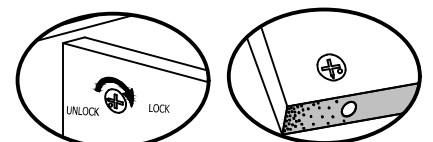

Proper orientation of CAM LOCK

# STEP39

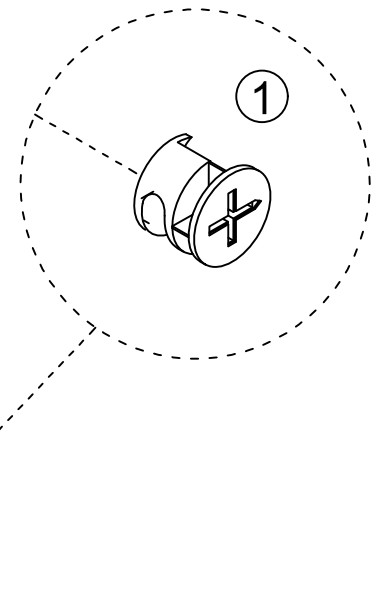
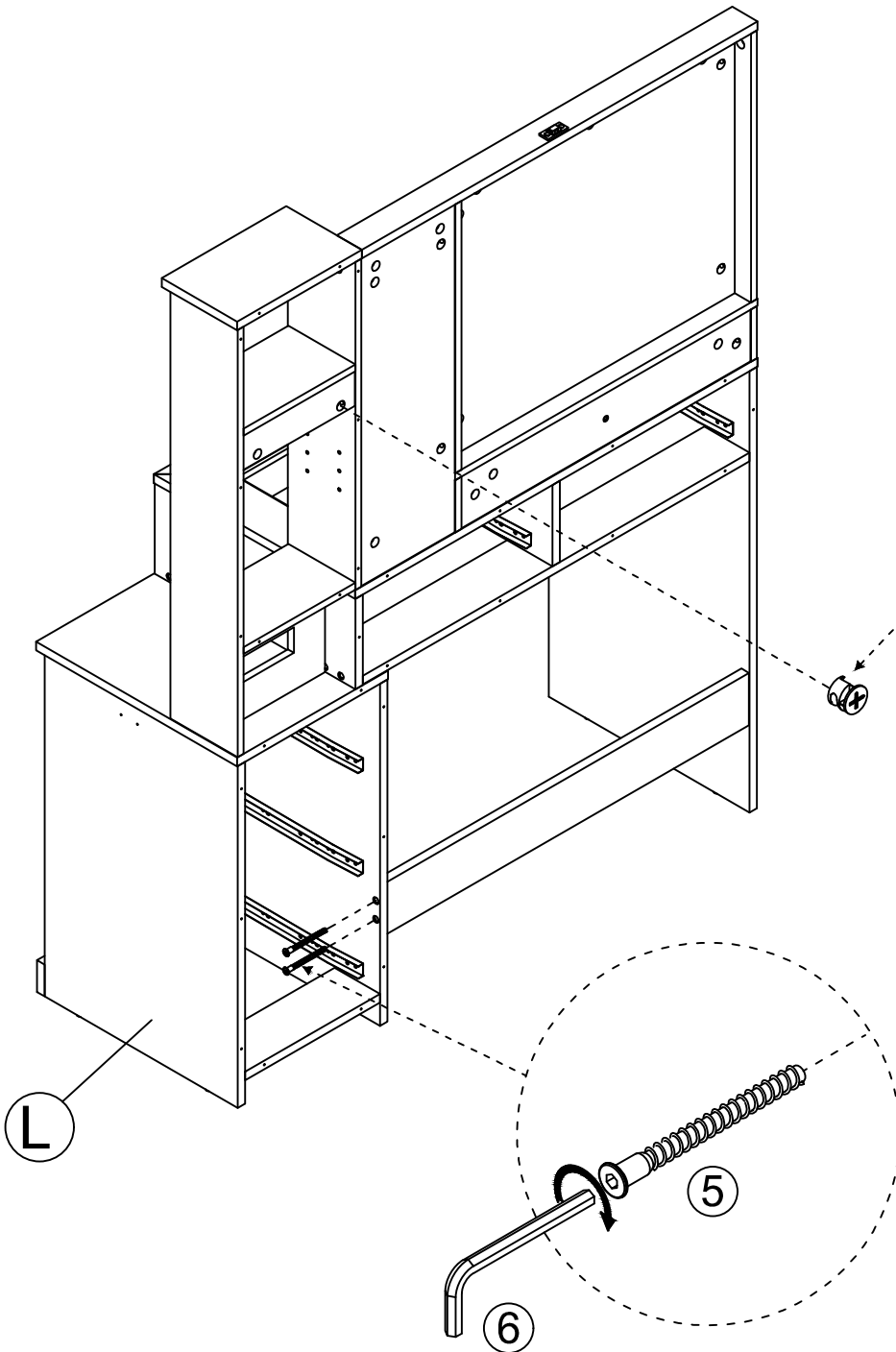
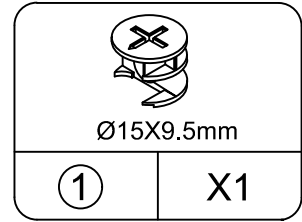
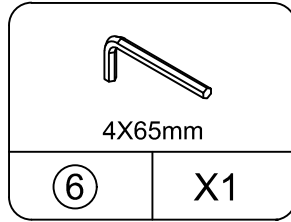
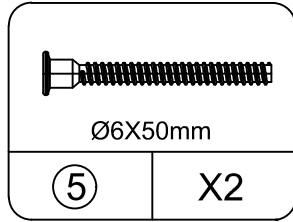
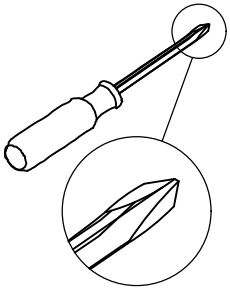

Insert the cam bolt into the hole first, then insert the cam lock and lock it.

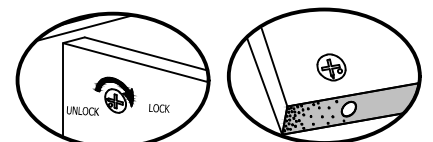

Proper orientation of CAM LOCK

# STEP40

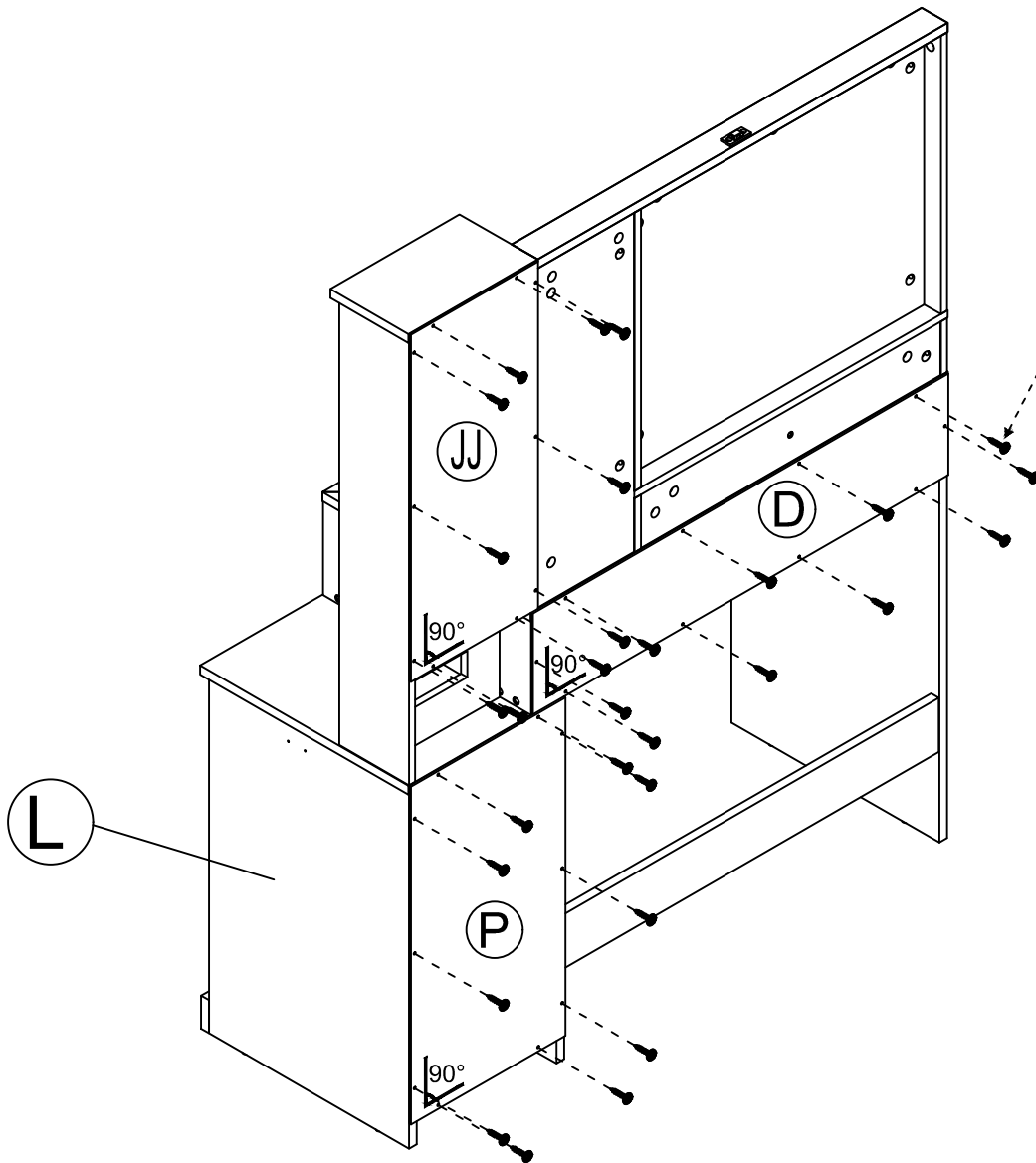
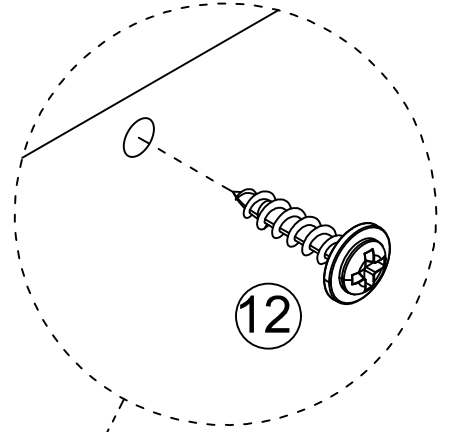
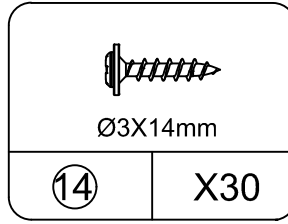
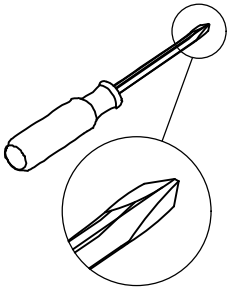

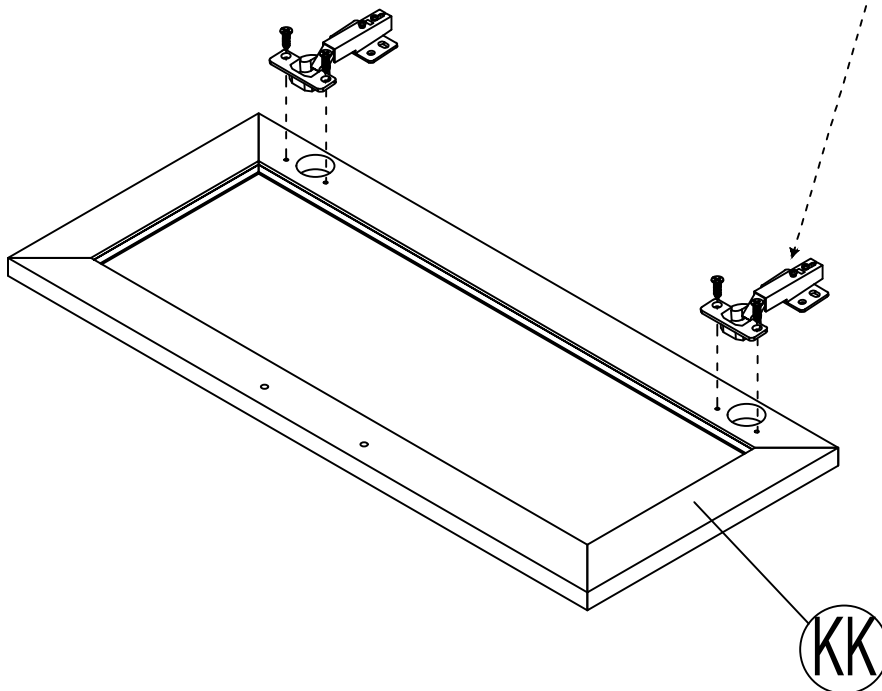
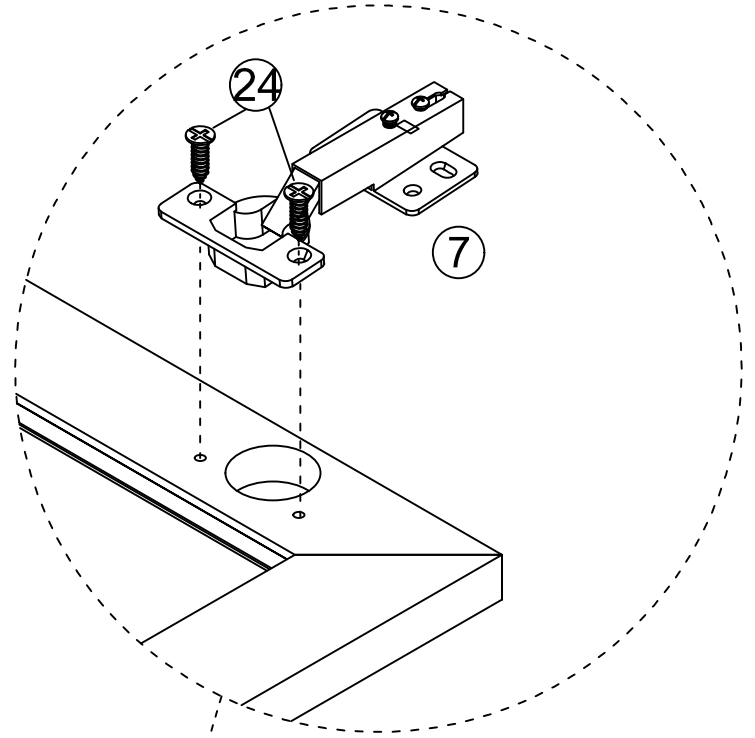
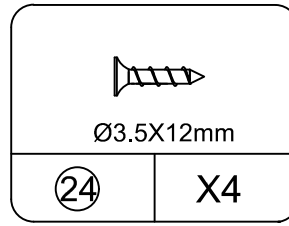
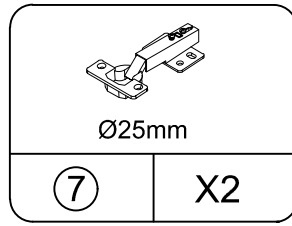
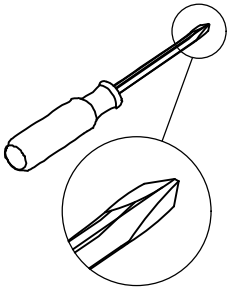

# STEP41

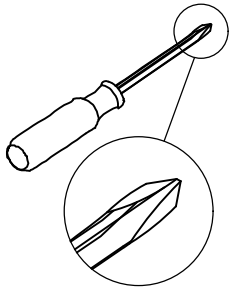

# STEP42



 114X19X33mm	
8	X1

 M4X19mm	
9	X2

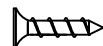
 Ø3.5X12mm	
24	X8

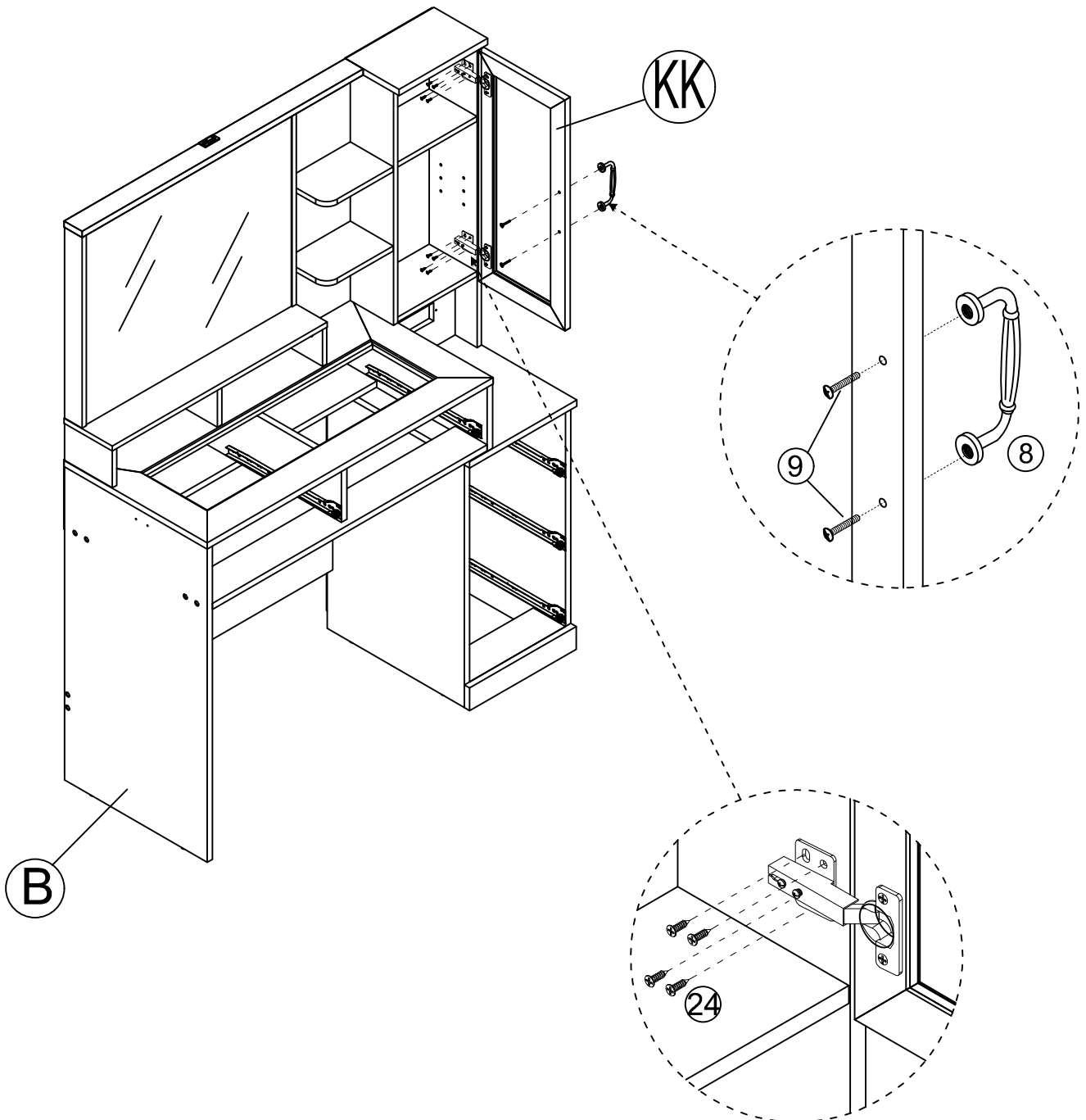

# STEP43

---

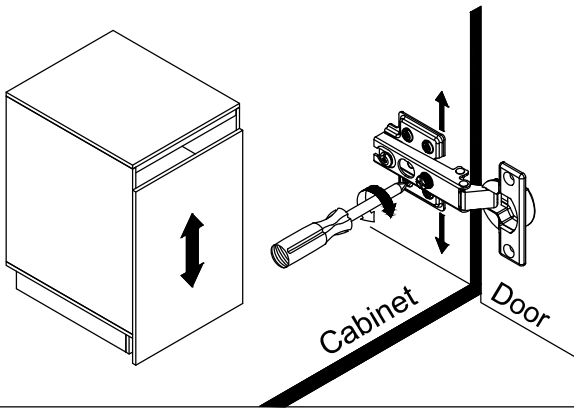
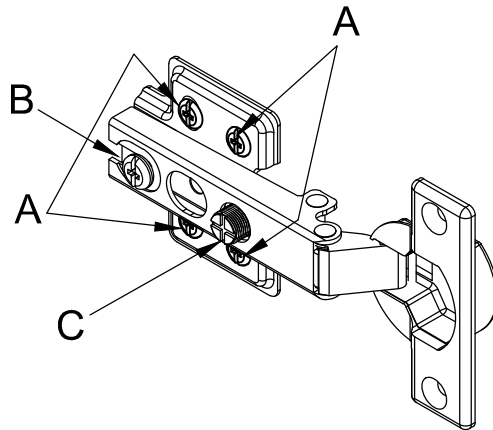

### To adjust the vertical height.

Loosen the four screws "A" on both hinges. Two of them are usually in slotted holes which allows you to adjust up or down by a few mm. Then tighten back up.

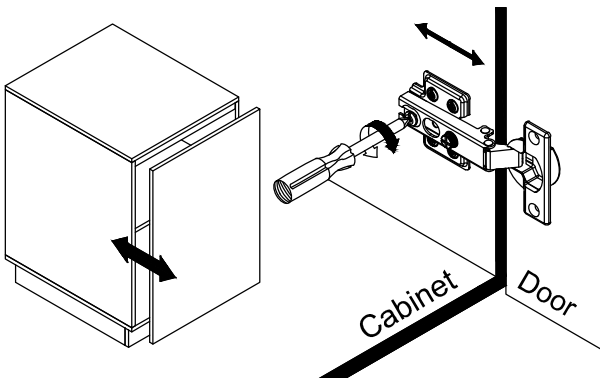

### To adjust depth.

Loosen screw "B" and adjust door, if the door can not be adjusted, please loosen screw "C", then try again. Tighten screw "B" and "C".

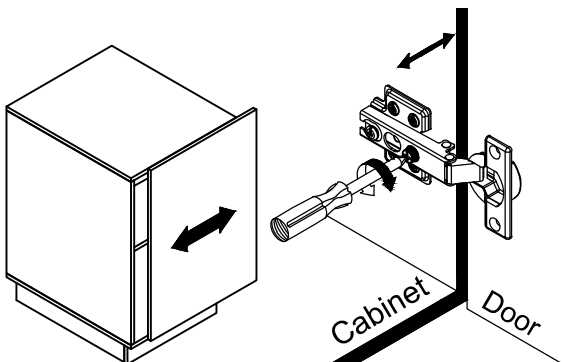

### To adjust side ways.

Turning the screw "C" on BOTH hinges on each door.

# STEP44

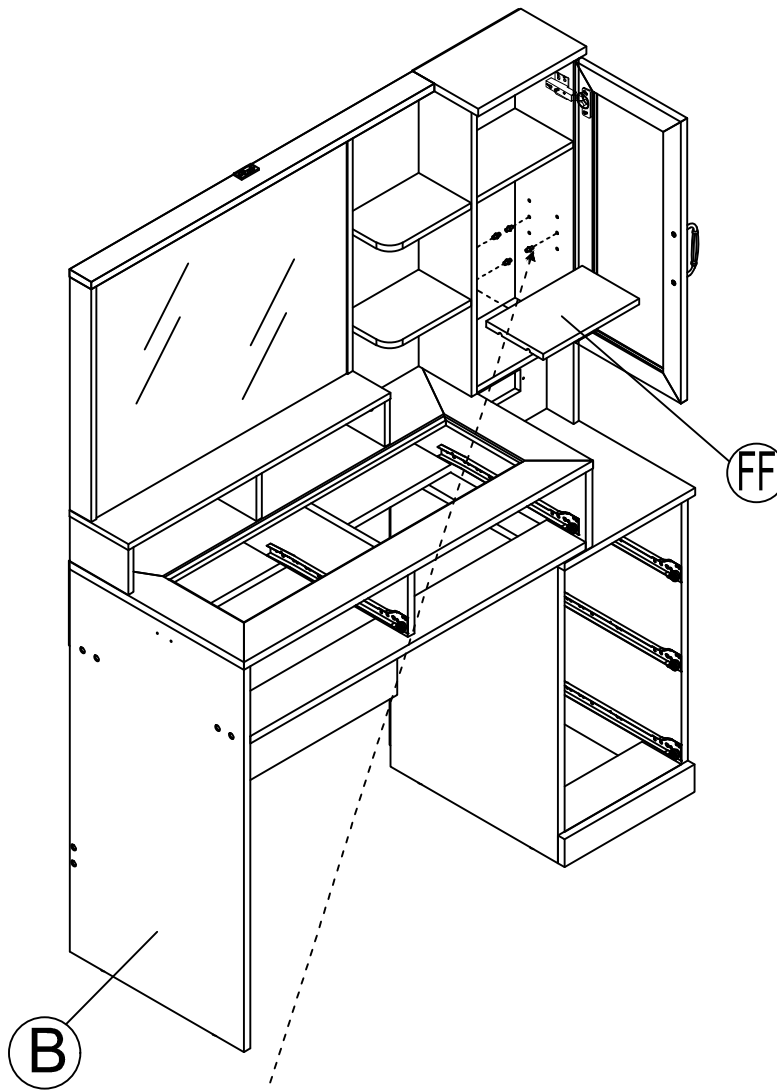
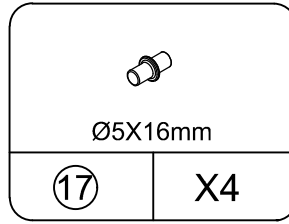
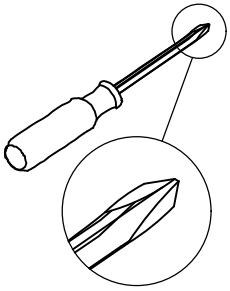

Step 1  
Select the desired height  
and put it in

Step 2  
Aim the board gaps down

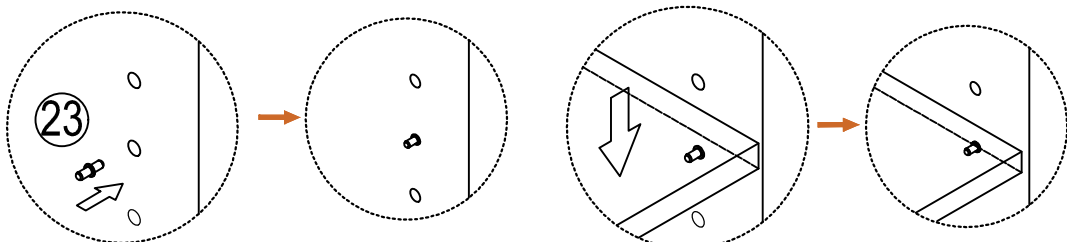

# STEP45

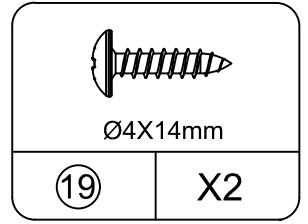
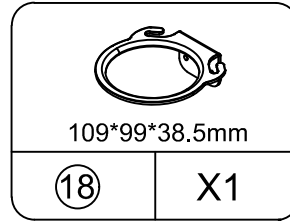
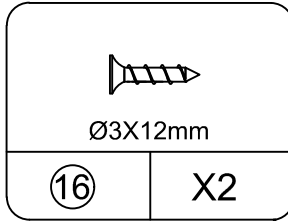
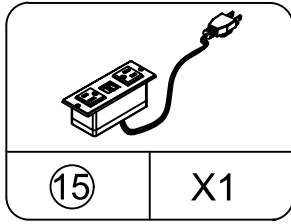
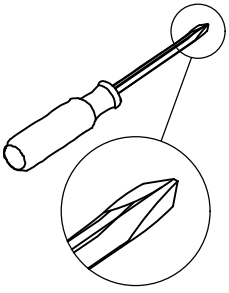

According to the needs of customers, install part 18 on the B or L board

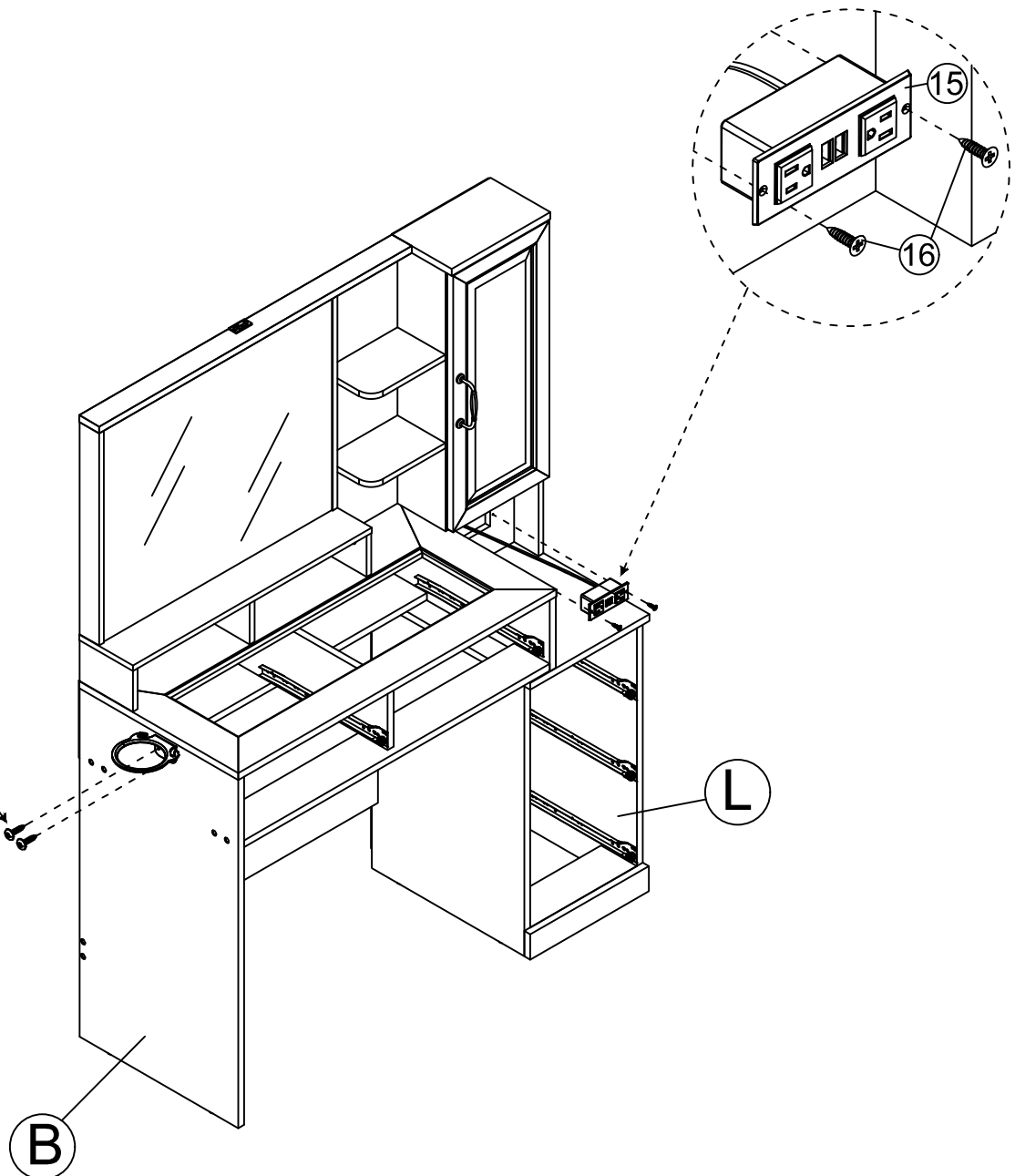
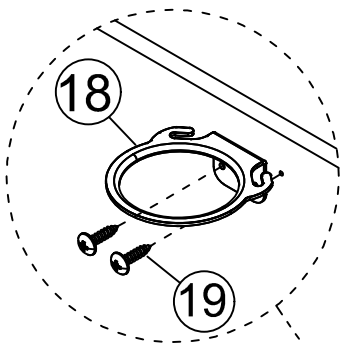



# STEP46

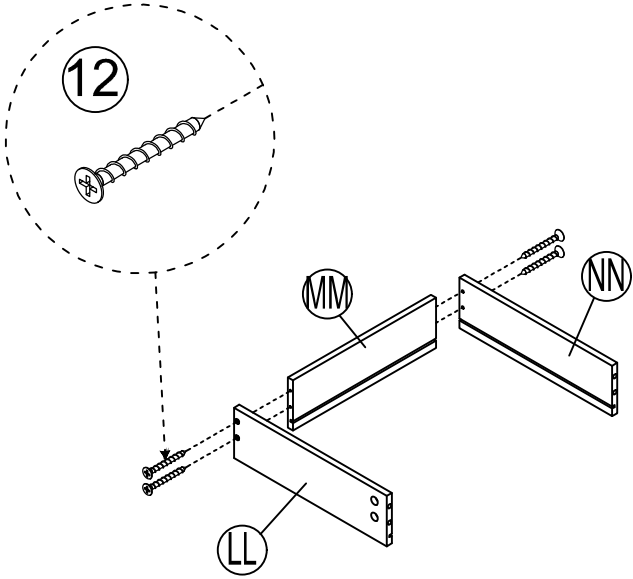
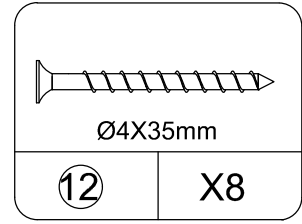
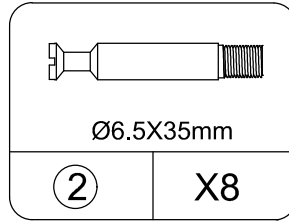
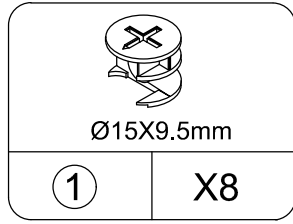
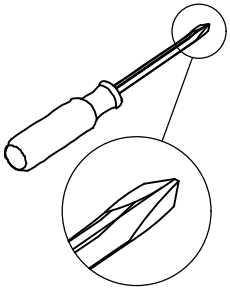

Step 1

Step 2

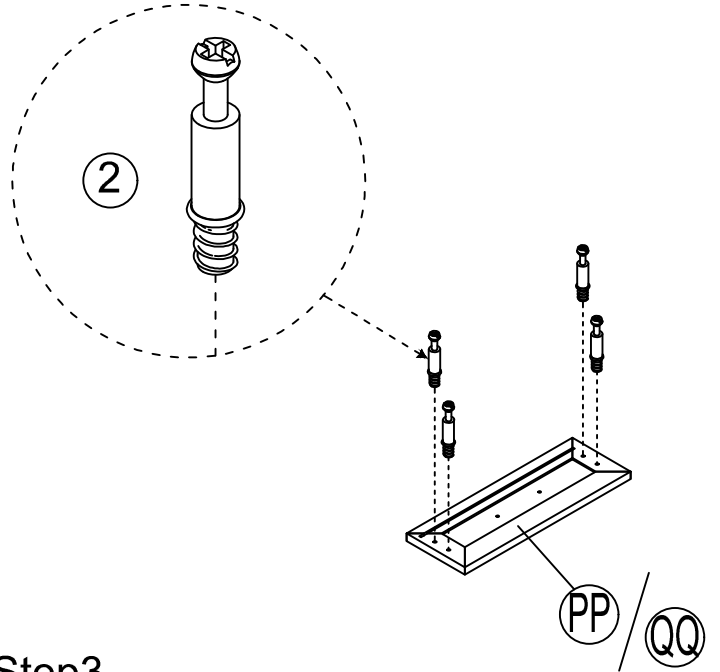

Step 3

Step 4

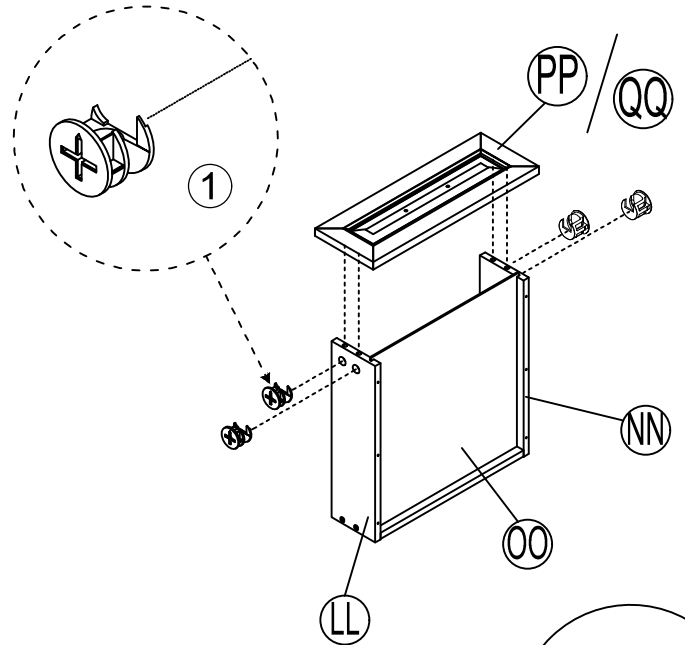
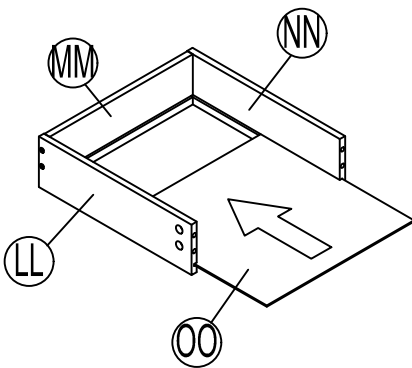

Insert the cam bolt into the hole first, then insert the cam lock and lock it.

# X2

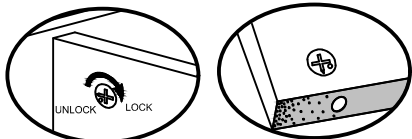

Proper orientation of CAM LOCK

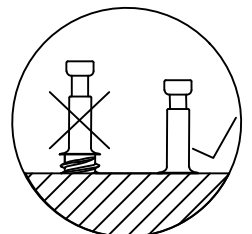

# STEP47

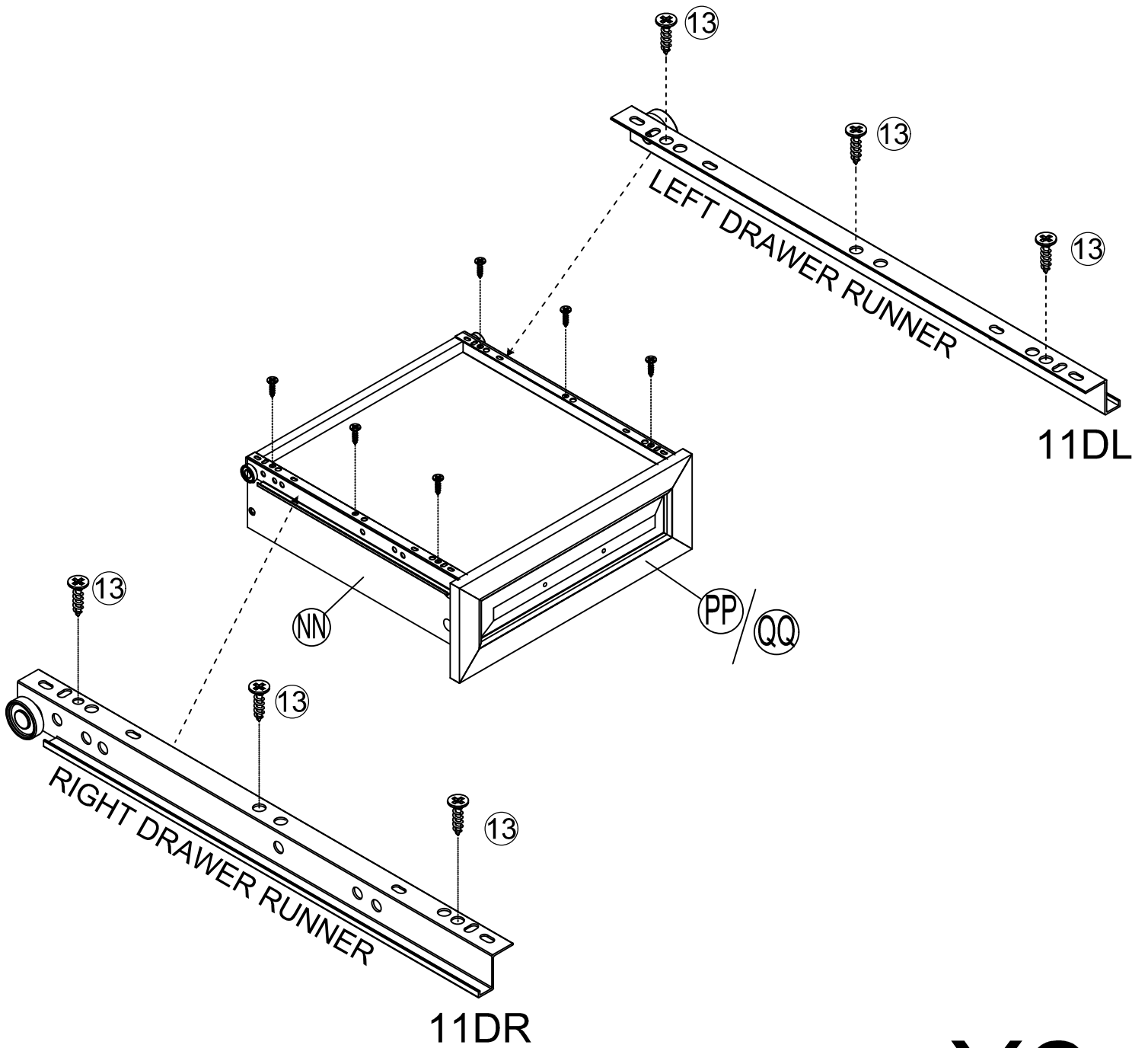
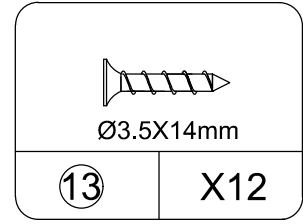
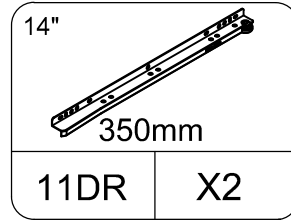
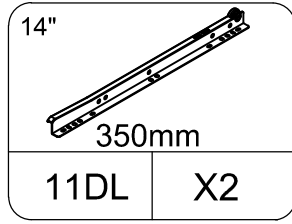
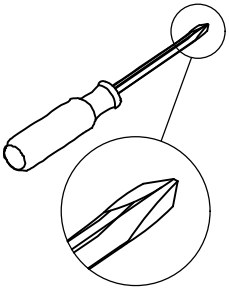

# X2

# STEP48

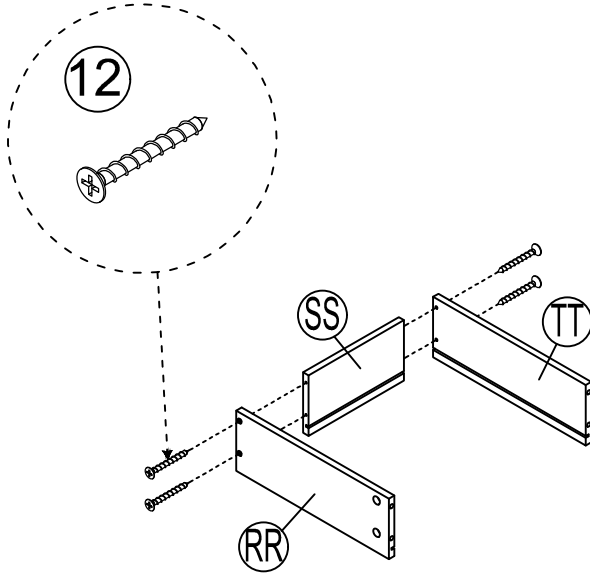
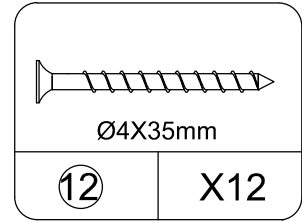
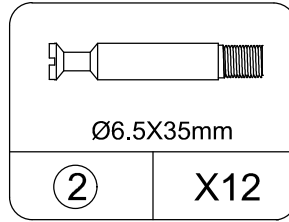
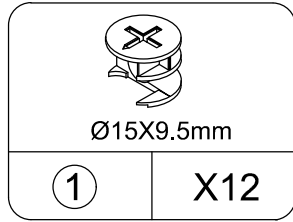
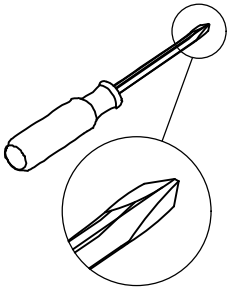

Step 1

Step 2

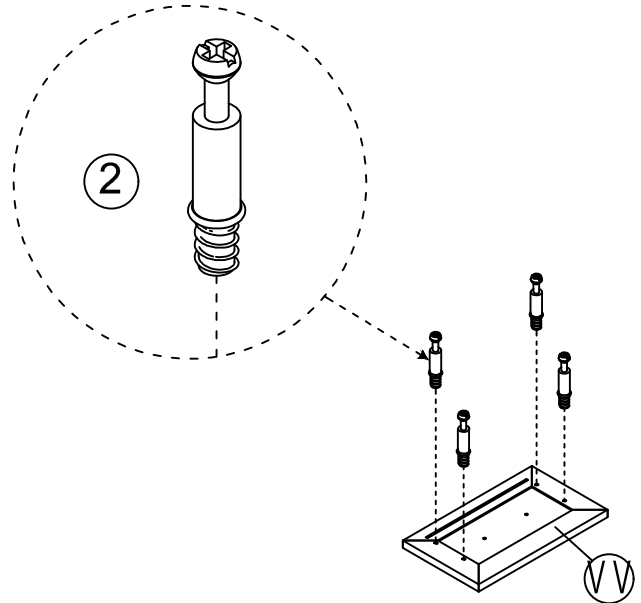

Step3

Step4

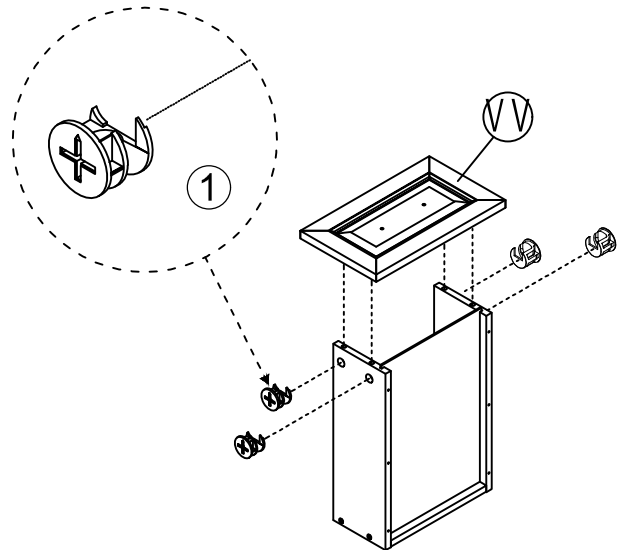
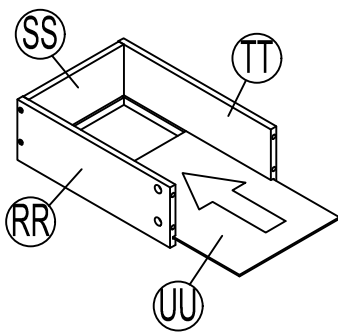

Insert the cam bolt into the hole first, then insert the cam lock and lock it.

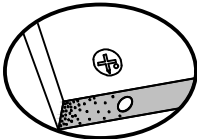

Proper orientation of CAM LOCK

# X3

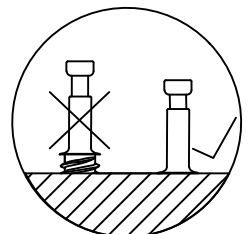

# STEP49

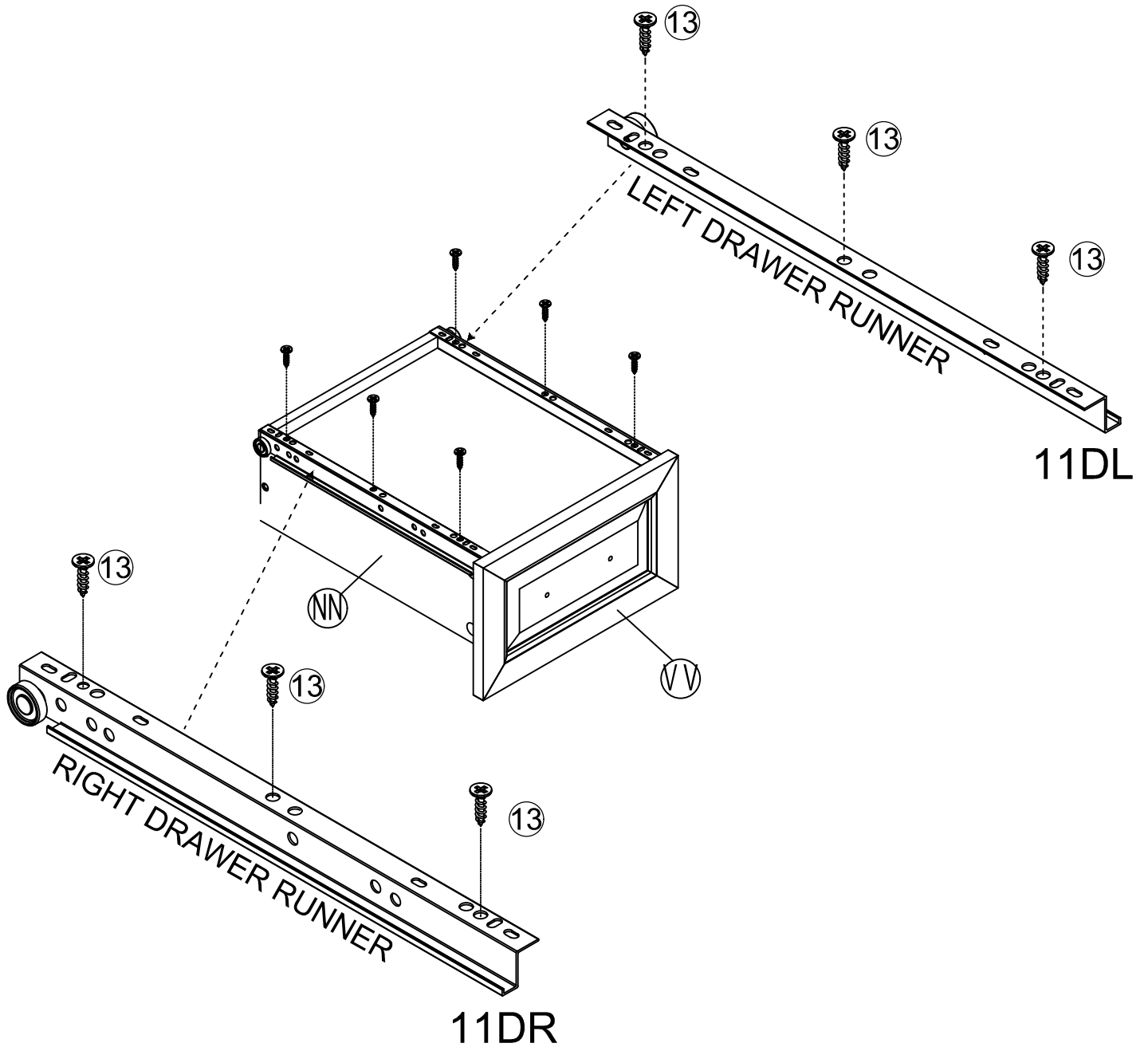
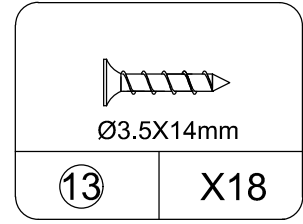
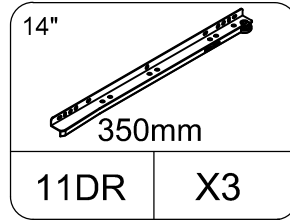
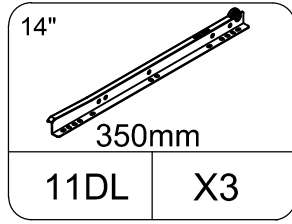
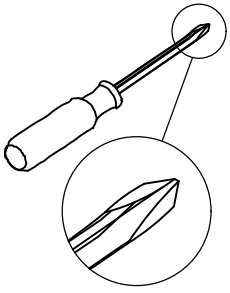

# X3

# STEP50

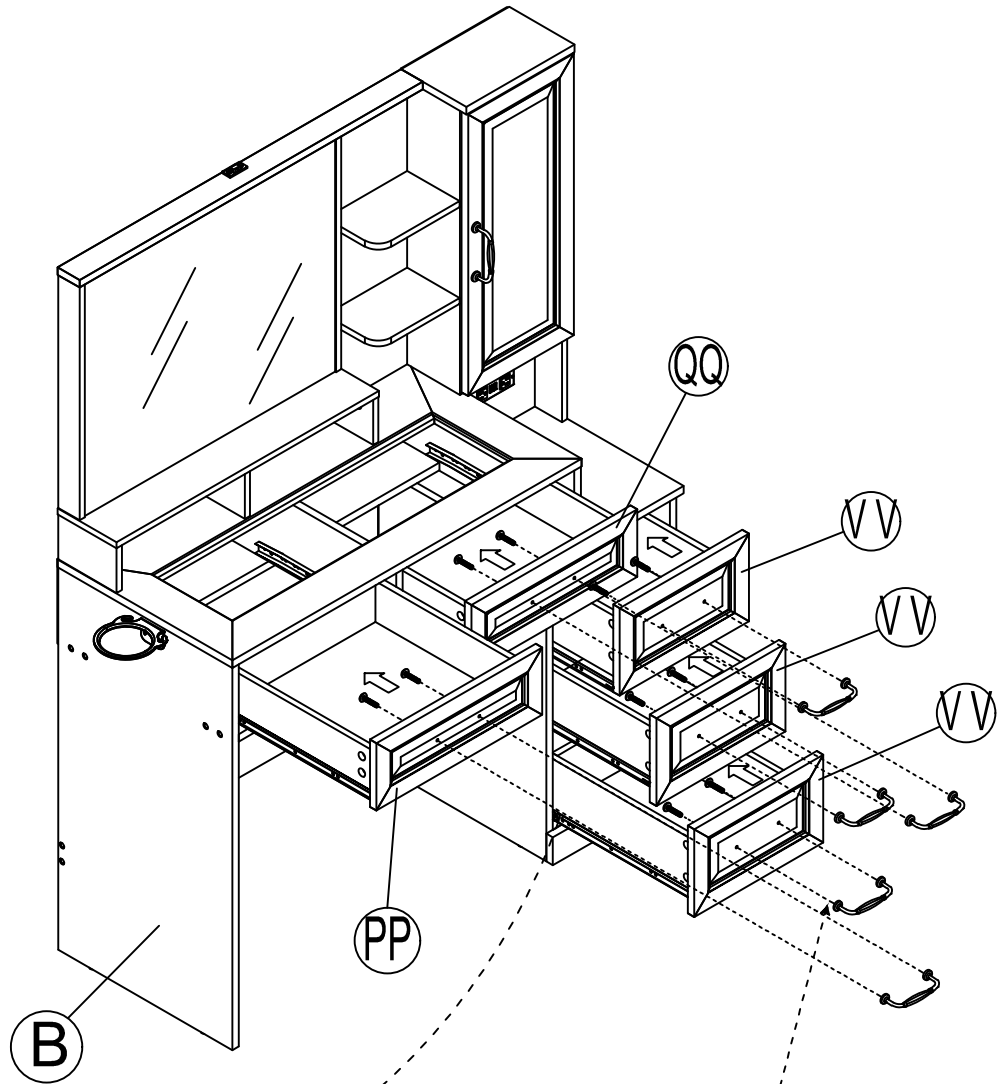
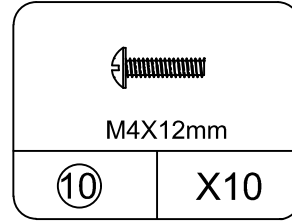
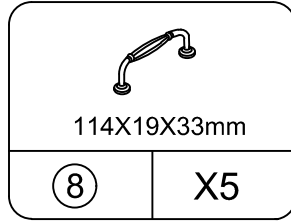
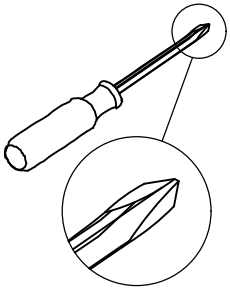

Cabinet Slide

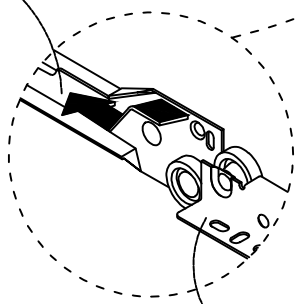

Drawer Slide

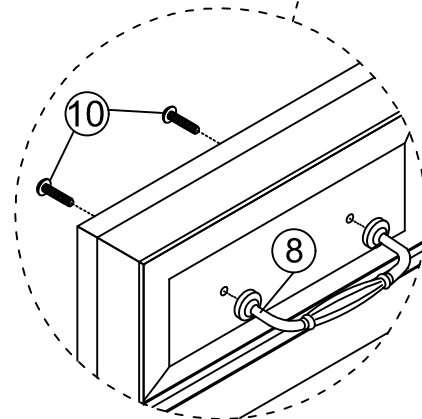

# STEP51

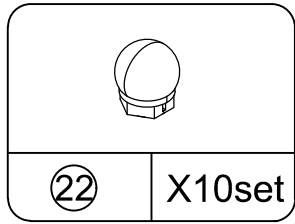

For specific installation and debugging, please read the last two pages

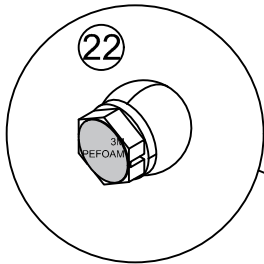

**ABS lamp holder**

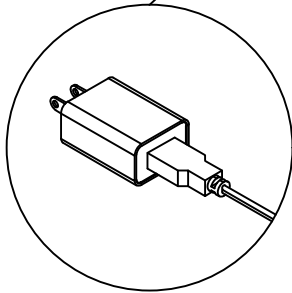

**USB power adapter**

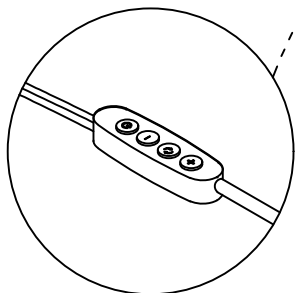

**Switch regulator**

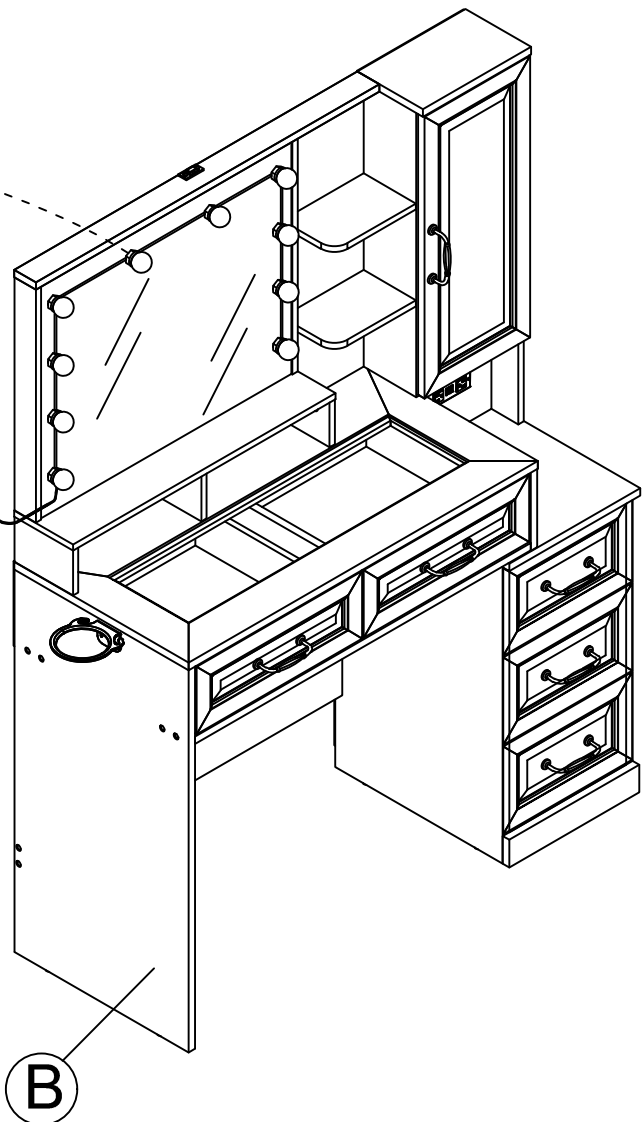

# STEP52

---

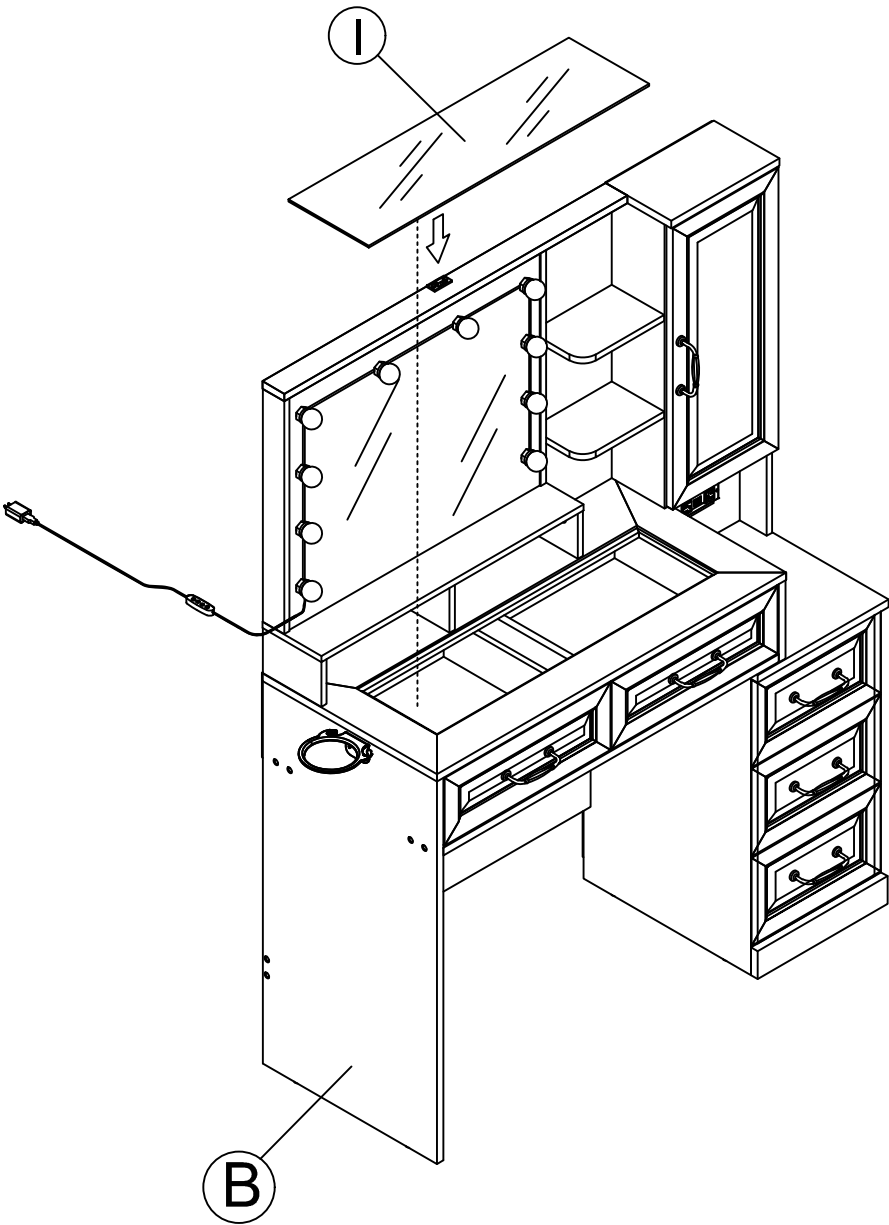

# STEP53

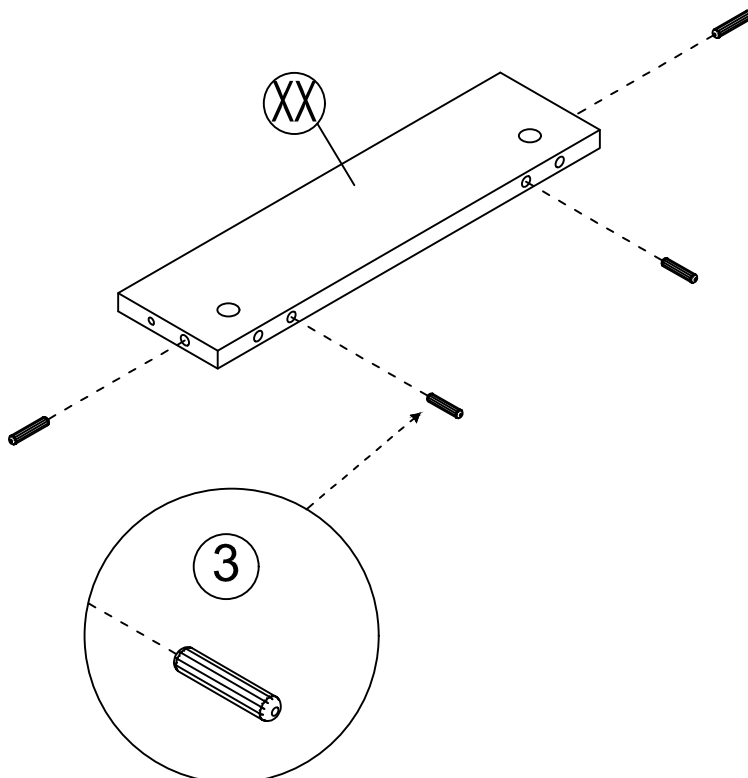
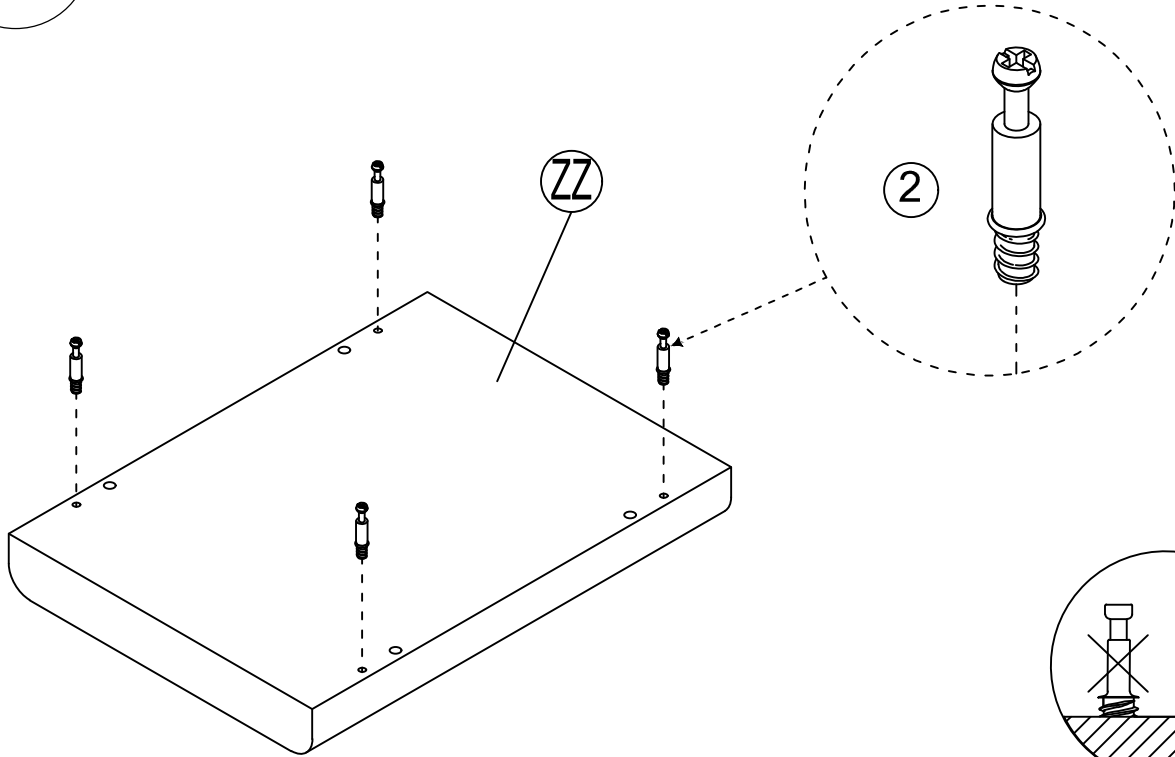
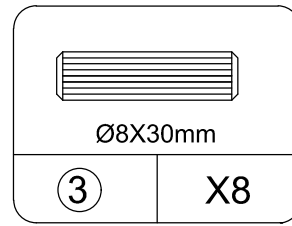
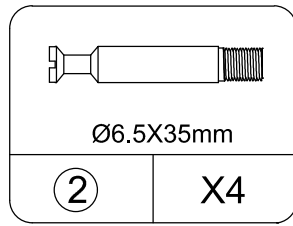
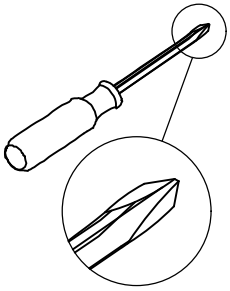

**X2**



# STEP54

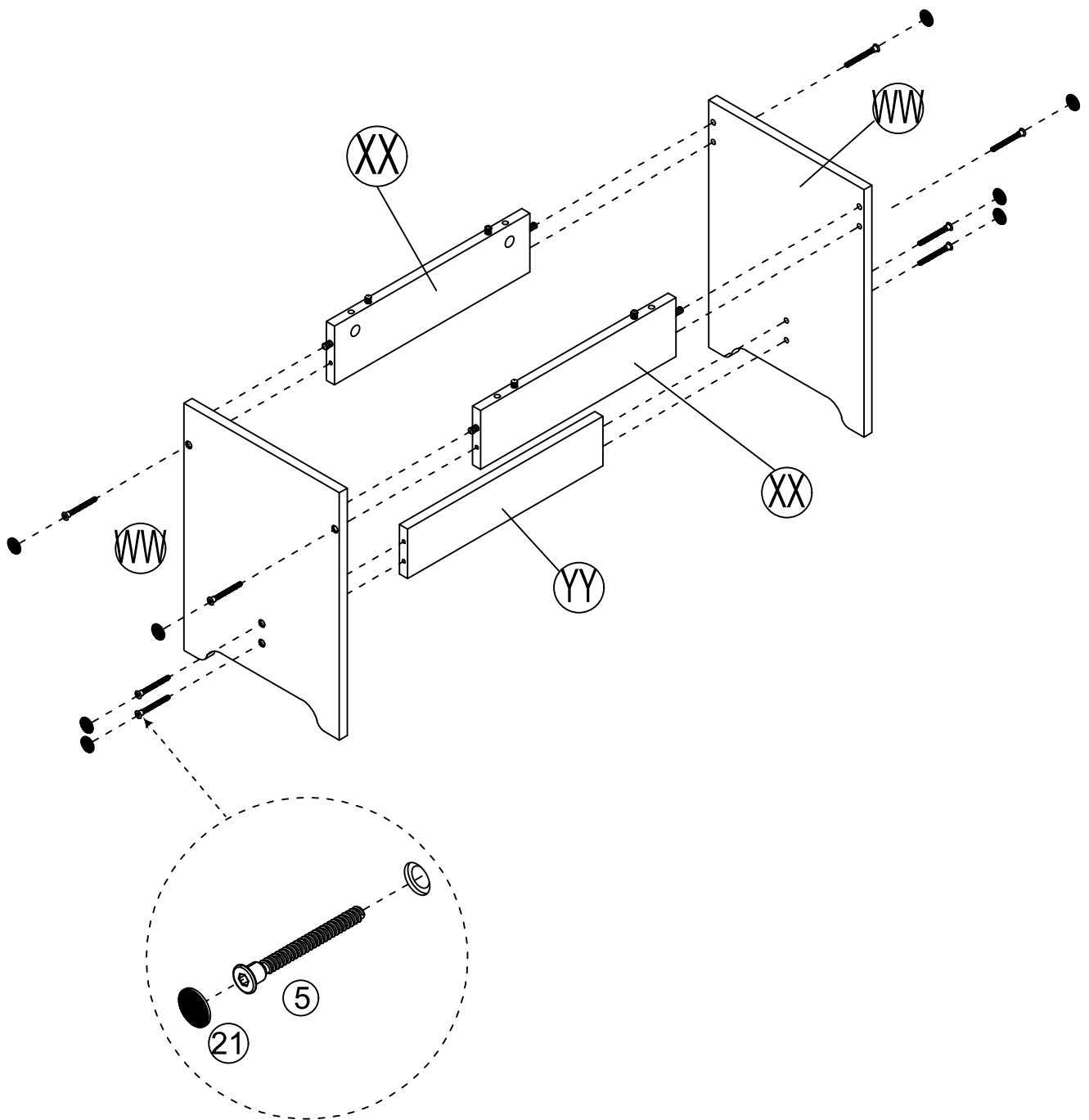
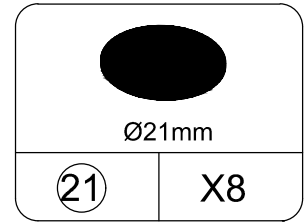
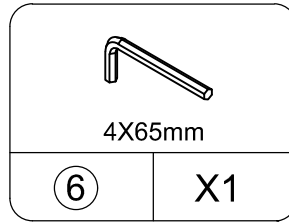
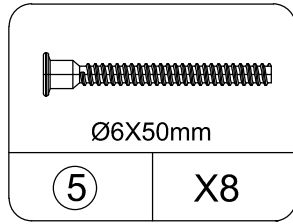
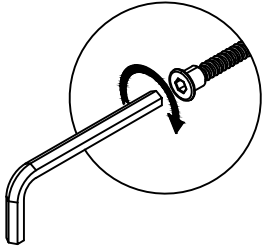

# STEP55

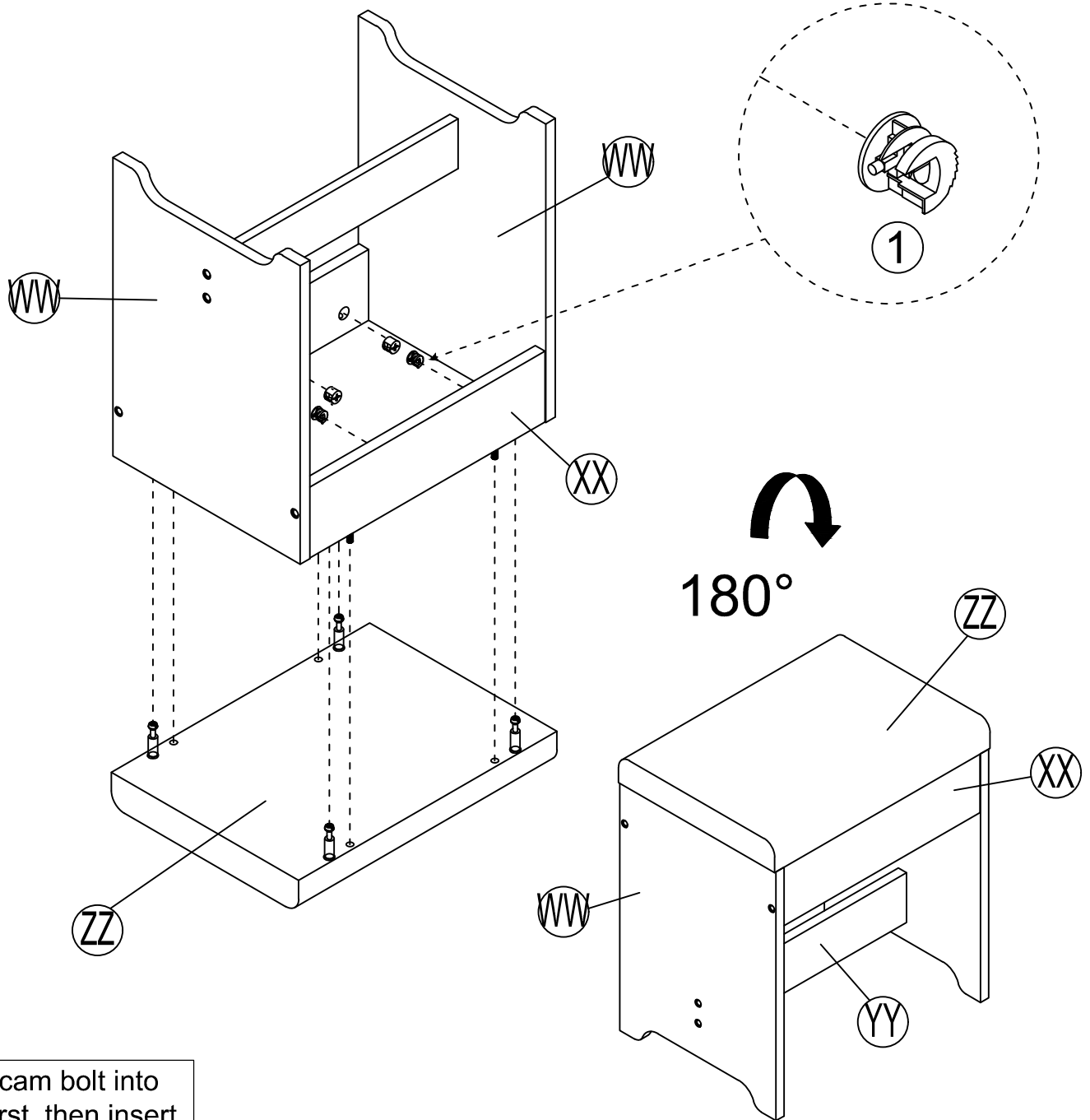
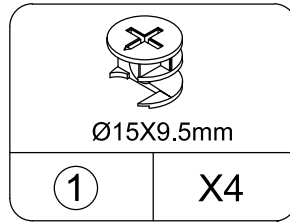
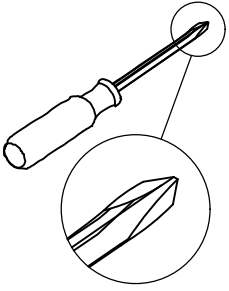

Insert the cam bolt into the hole first, then insert the cam lock and lock it.

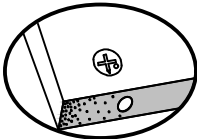

Proper orientation of CAM LOCK

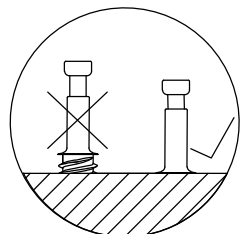

# STEP56

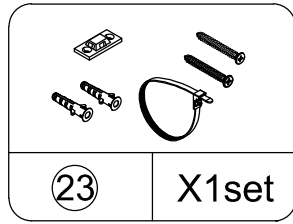
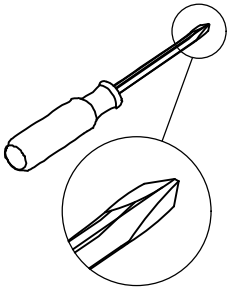

**NOTE:** The tipping restraint hardware included is for wooden stud wall construction. It must be attached to a wall stud. Depending upon your wall construction different anchor hardware may be required. Please contact your local hardware store for assistance. Young children can be seriously injured by tipping furniture. You must install the tipping restraint hardware with the unit to prevent the unit from tipping, causing any accidents or damage. The tipping restraints are intended only as a deterrent and are not a substitute for proper adult supervision. The tipping restraints are not earthquake restraints. If you wish to add the extra security of earthquake restraints, they must be purchased and installed separately.



## Install the tipping restraint hardware

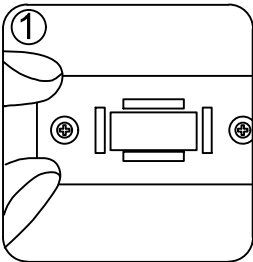

1. make mark on the wall

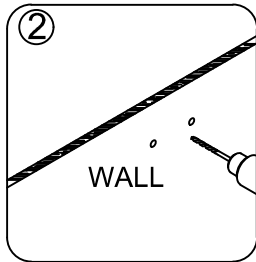

2. drill two Ø6 holes on the wall

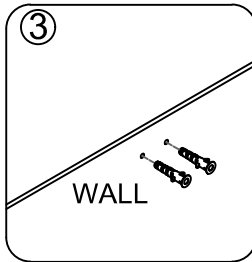

3. put two anchors in the holes

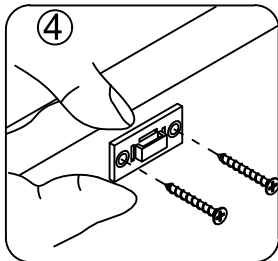

4. fix the device on the wall by the long screws

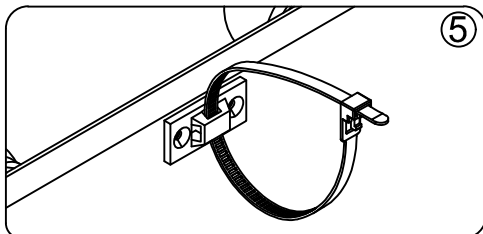

5. Push the cabinet close to the wall so that the two bases are close to each other, and then put on nylon tie to tighten it.

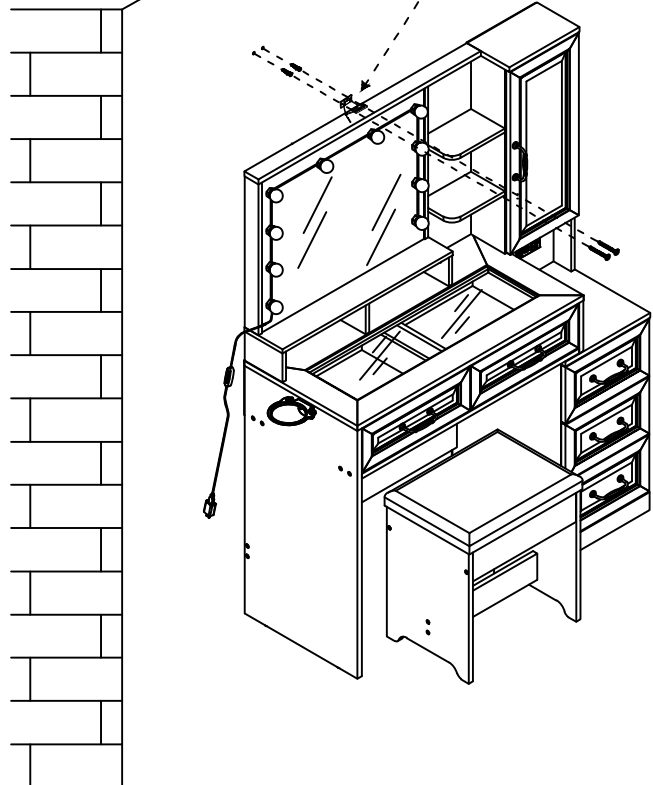
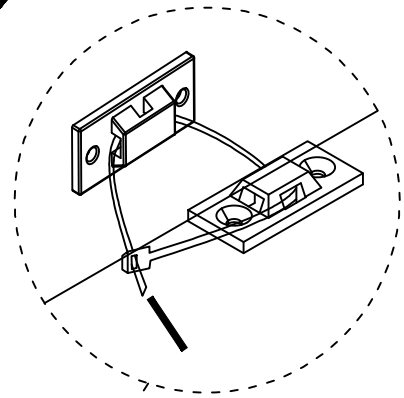

# CONTINUED

---

Thank you for purchasing our company's DIY makeup mirror fill light products, this product supports DIY own home mirror, instantly make their own mirror into a modern fashion makeup with LED fill mirror. Even more interesting is that you can adjust the color temperature by yourself!

## Product Features:

1. The standard USB power supply, safety voltage.
2. PC soft mask, don't stab the eyes.
3. All transparent lines, beautiful and stylish.
4. Multilevel luminance adjustable, beauty skin and beauty face.
5. The color temperature is adjustable with the buttons.
6. By rotating the bulbs, the excess connecting wire can be hidden in the bottom shell make the installation more simple and beautiful.

## Product parameters:

Product Name: Vanity Mirror Lights  
Bulb Size: 45 X 45 X 47 mm.  
Power Supply: Standard USB 5V 2A or above.  
LED colour temperature: 3000K and 6500K.  
Power: a single lamp maximum power is 0.8W.  
Material: ABS lamp-holder and PC lampshade.

## Wisdom in design:

Rotate the bulbs clockwise or anticlockwise, the ball bubble spacing becomes shorter, the connection line shrinks and hides in the ball bubble bottom cover. Simple and beautiful installation, use more comfortable.

## Rest assured dressing:

USB 5V low voltage power supply, safe! Multilevel luminance adjustable, suitable for different dressing needs.  
Three kinds of color temperature can be adjusted: Warm White, Natural White and Pure White.

## Vanity Mirror Lights

The color temperature is adjustable

## Instructions

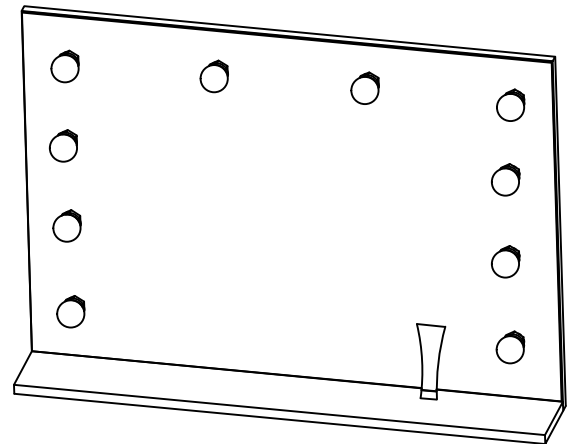

See Yourself Better!!!

Wisdom in design, Enjoy your life!

# CONTINUED

Use the installation details see inside pages.

## Functional Description:

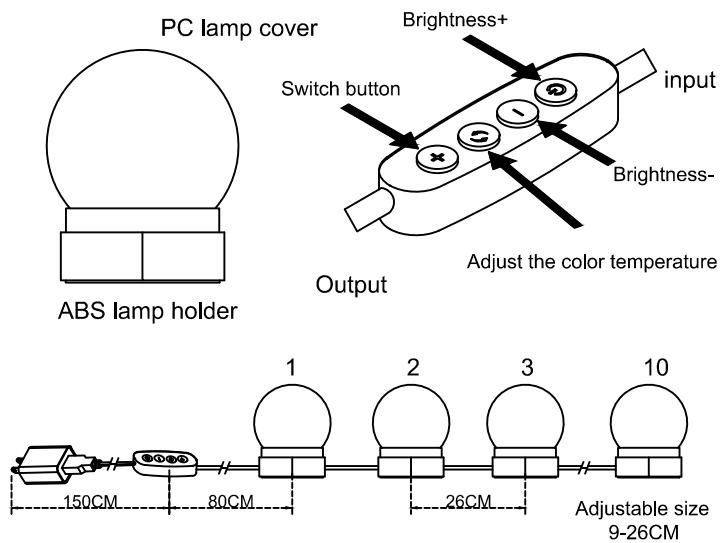

## Install reference diagram:

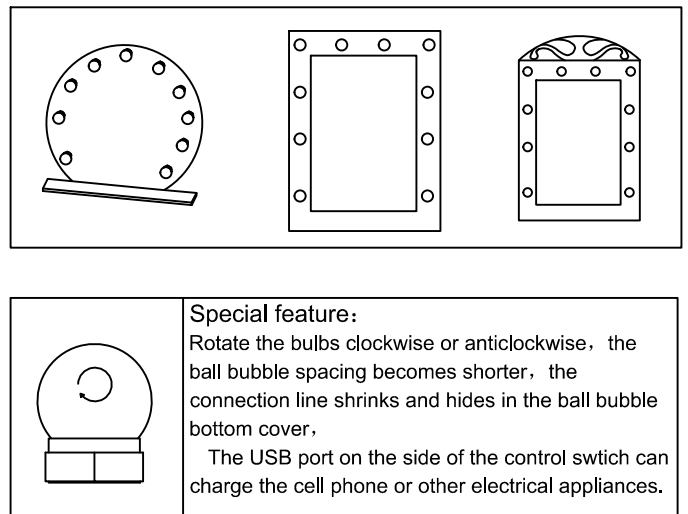

## Application notes:

1.It is recommended to choose 2A or above USB power adapter, mobile phone charger and other standard USB mobile power can be use.

2.The product uses double-side adhesive paste installation of the bonding surface must be clean, dry, smooth, can not have rust and oil.

3.The wire can be adjustable through the winding between the base slot, and the bulb spacing can be adjusted between 9-26CM.

Reminded: When the bulb is pasted, please press the product for about 30 seconds, it tacks 24 hours to achieve the best adhesive strength.

**See Yourself Better!!!**

## Installation steps:

1.Cosmetic mirror or be installed surface treatment: should be sticky surface should be try, clean,and no rust,oxidation,grease, dust and other pollutants.

2.According to the design of the number of mirrors and bulbs, each bulb installation location,note the lamp spacing of up to 26CM the minimum apacing of about 9 CM.

3.Remove the product to determine the power and control switch to place the seat is appropriate to determine the first light paste location(with the control switch to connect the first line).

4.The bottom of the product is double-side adhesive tape tear off the film,and then affixed to the first lamp position,forced down, so that double-side adhesive is pasted better.Make the tape and the bonding surface get full contact.

5.After the installation,the rotating bulbs will shrink the redundant connecting wires and hide them in the bottom shell to ensure the simple and beautiful installation and achieve the best use effect.

6.When you use the lights,you can adjust the color temperature and the brightness with the function buttons.And choose your favorite color!