

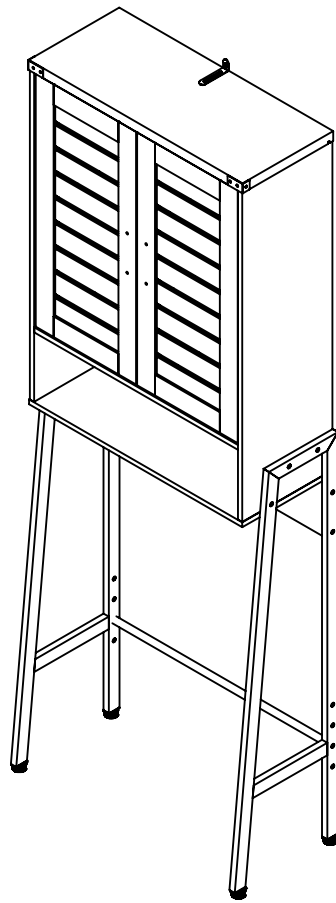

F2V200HW0M



As this item contains many parts, please read the installation instruction carefully before installation and complete the installation with the cooperation of your partner. Please use tools properly and carefully. If you have any questions about the product and installation, please contact us.

service@vabchesofficial.com

Our professional after-sales team will serve you online all day.

Before You Start

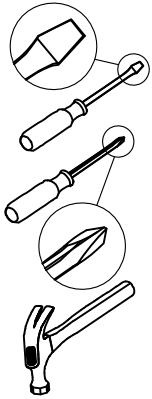

- ✓ Read through each step carefully and follow the proper order
- ✓ Separate and count all your parts and hardware
- ✓ Give yourself enough room for the assembly process
- ✓ Have the following tools: Flat Head Screwdriver, #2 Phillips Head Screwdriver and Hammer
- ✓ Caution: If using a power drill or power screwdriver for screwing, please be aware of to slow down and stop when screw is tight. Failure to do so may result in stripping the screw.

Helpful Hints

PEOPLE NEEDED FOR ASSEMBLY: 1-2

- Open your item in the area you plan to keep it to avoid excessive heavy lifting.
- Identify, sort and count the parts before attempting assembly.
- Compression dowels are lightly tapped in with a hammer.
- Slides are labeled with an **R** (right) and **L** (left) for proper placement.
- Make sure to always face the point on the top of the Cam Lock towards the outer edge.
- Use all the nails provided for the back panel and spread them out equally.
- Back panel must be used to make sure your unit is sturdy.
- Do NOT use harsh chemicals or abrasive cleaners on this item.
- Never push, pull, or drag your furniture.







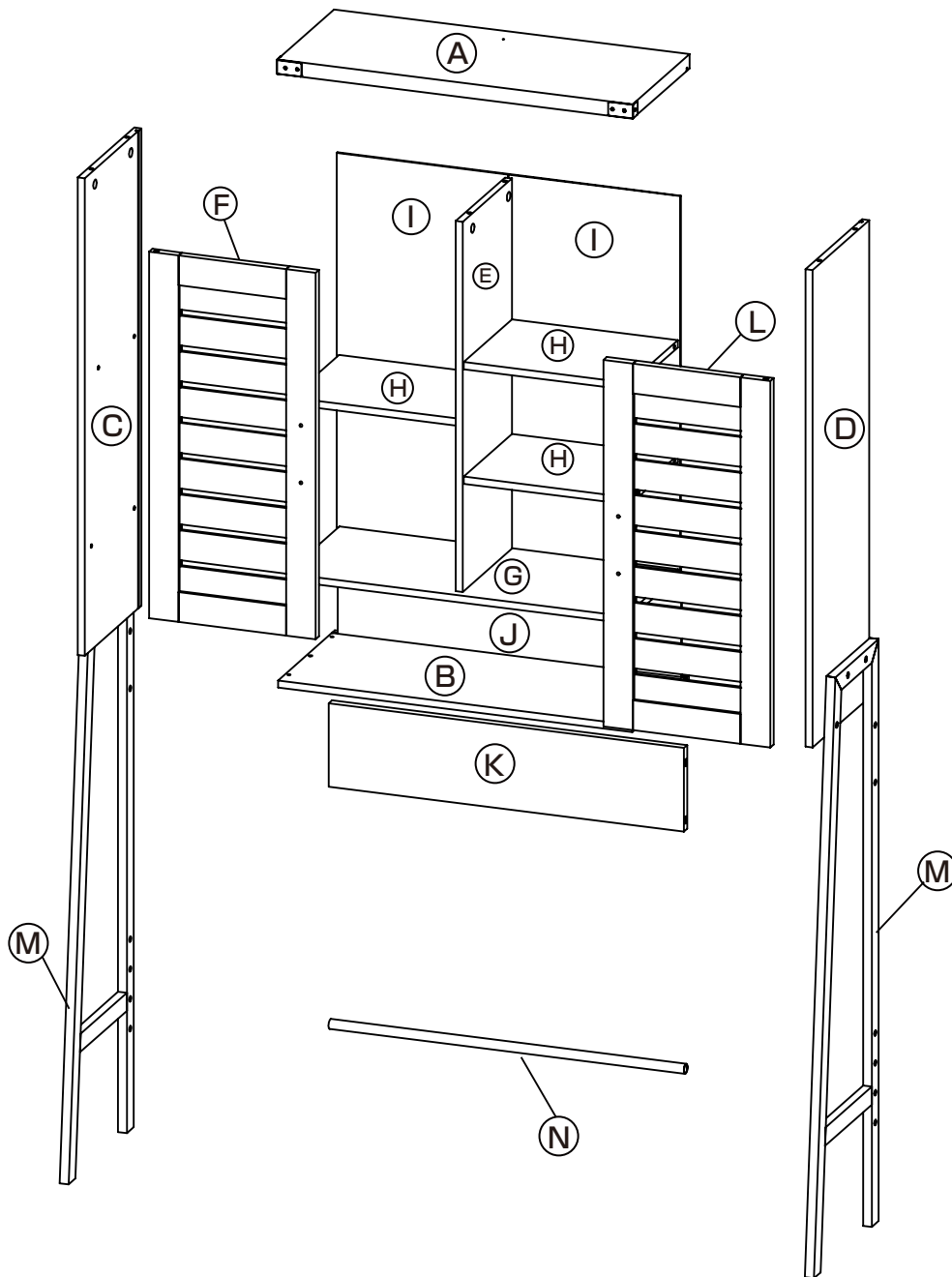



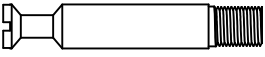
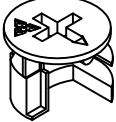

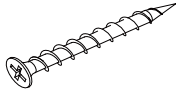
Board Identification

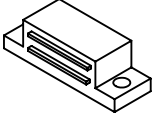
Not actual size

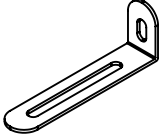
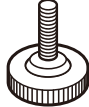
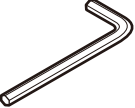

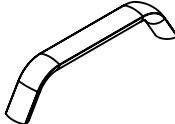
Part List

				
① X 22	② X 22	③ X 3 ø6X30mm	④ X 6	⑤ X 12 M6x25
CAM LOCK spare:2	CAM BOLT spare:2	WOOD DOWEL	SCREW spare:1	BOLT spare:1
				
⑥ X 4	⑦ X 2	⑧ X 5	⑨ X 1	⑩ X 4
BACKBOARD CLIP	SCREW	SCREW	WALL BRACKET	ADJUST FEET
				
⑪ X 1	⑫ X 1	⑬ X 2	⑭ X 4	
HEX KEY	EXPANDING TUBE spare:1	HANDLE	BOLT	

Cam Lock Fastening System

This Cam Lock Fastening System will be used throughout the assembly process.

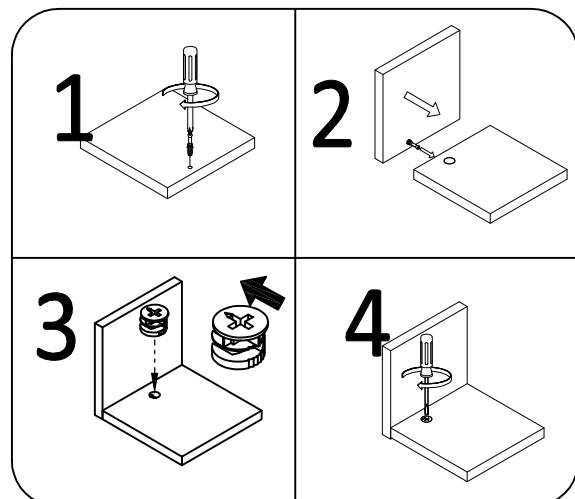

STEP 1

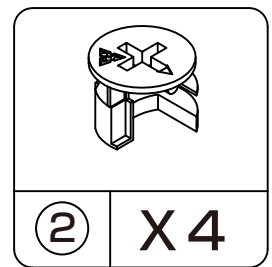
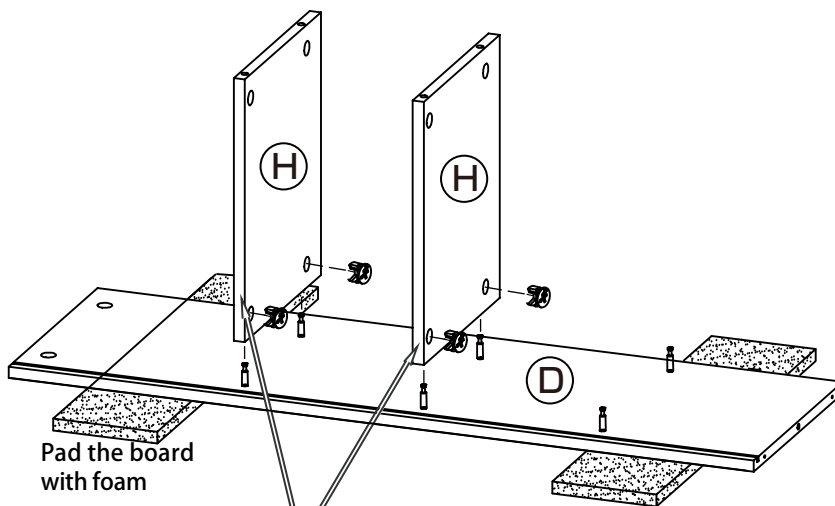
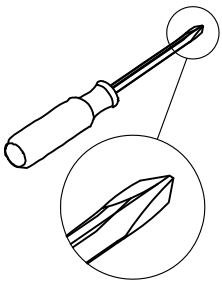
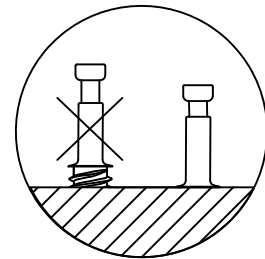
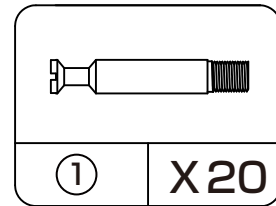
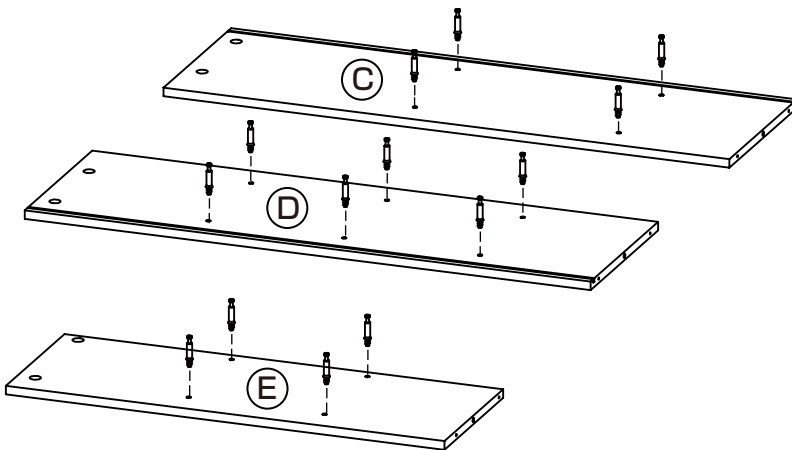
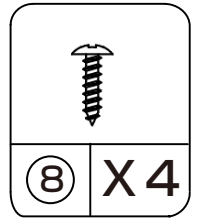
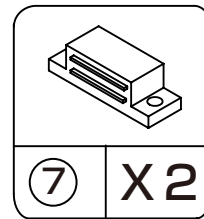
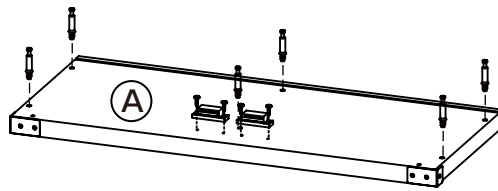
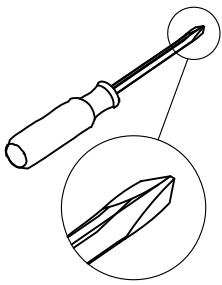

Without Edge Banding

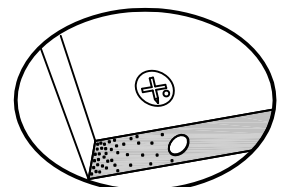
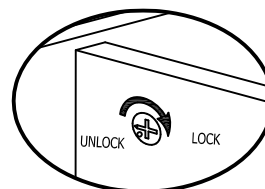

Proper orientation of CAM LOCK

STEP2

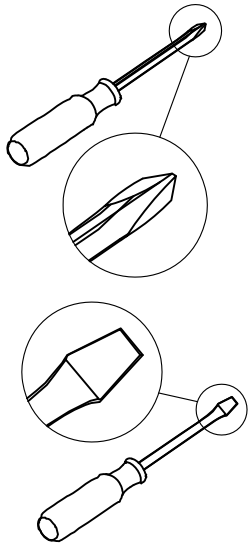

Without Edge Banding

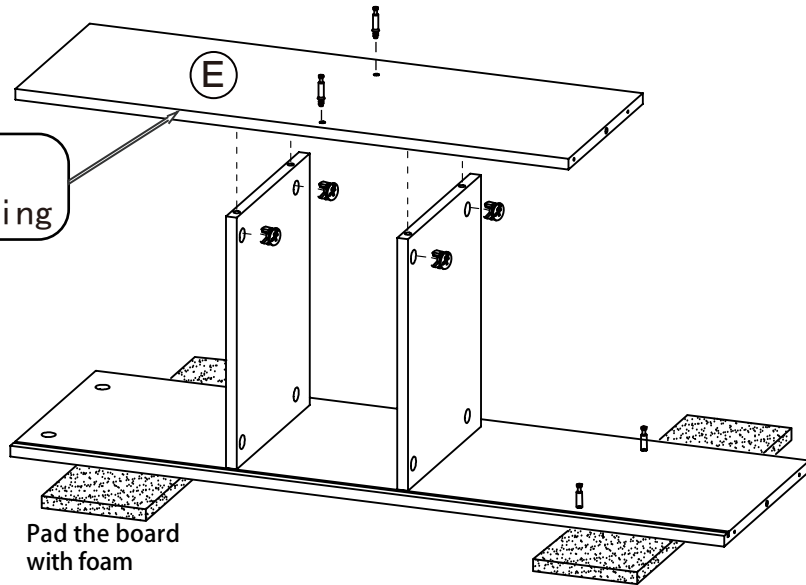
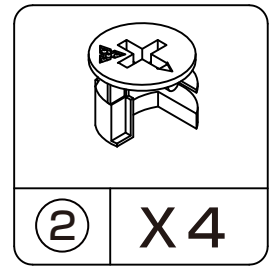
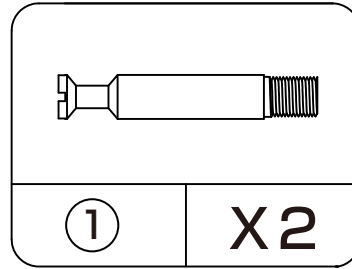

Pad the board with foam

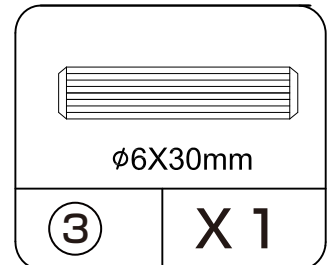
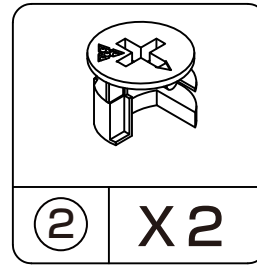

Without Edge Banding

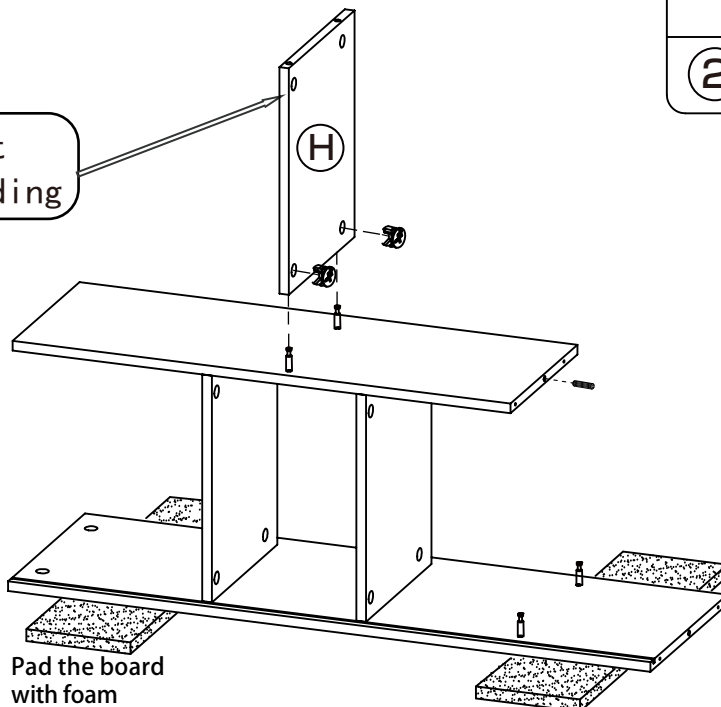

Pad the board with foam

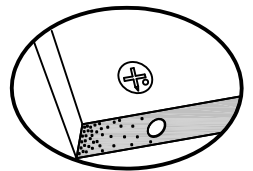
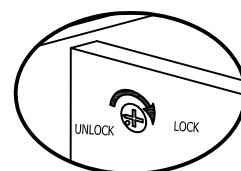

Proper orientation of CAM LOCK

STEP 3

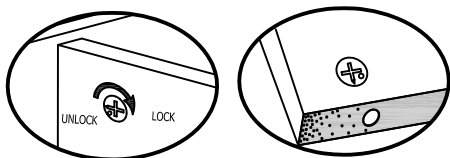
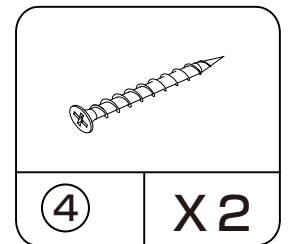
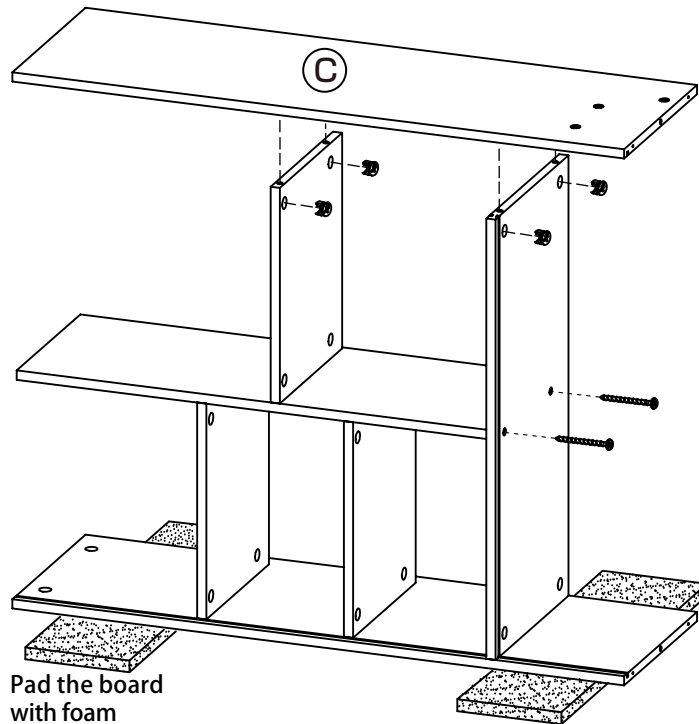
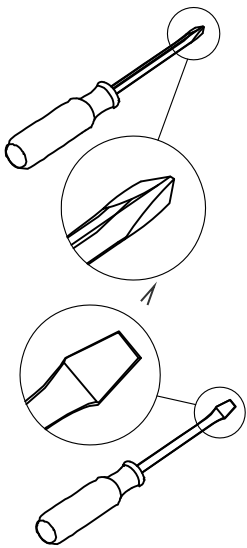
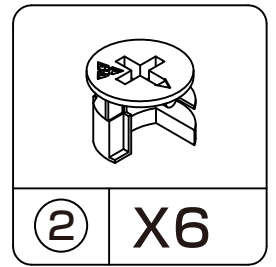
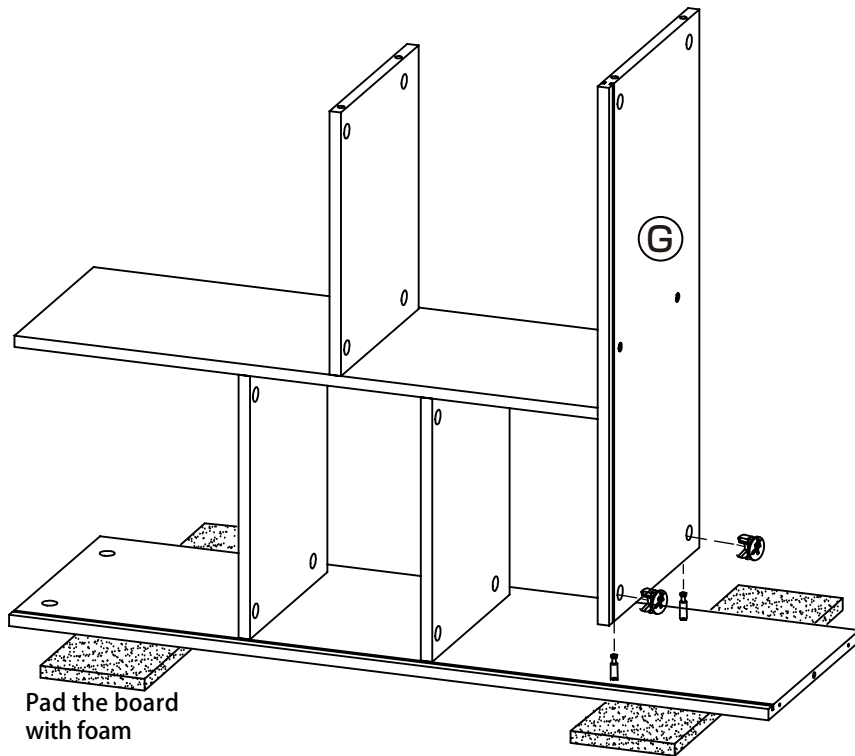

Proper orientation of CAM LOCK

STEP4

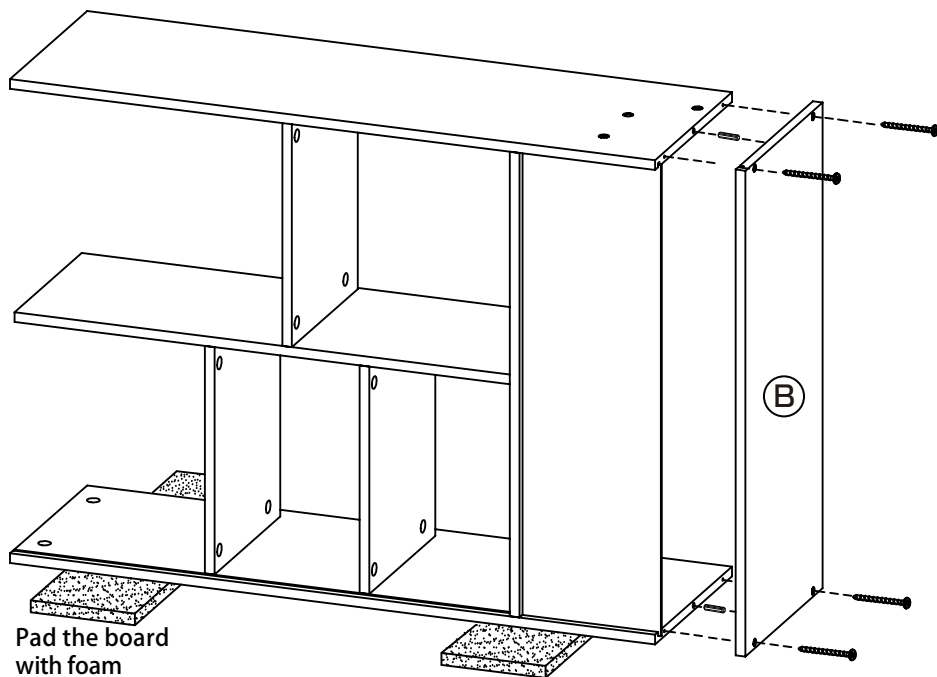
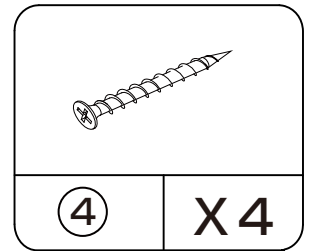
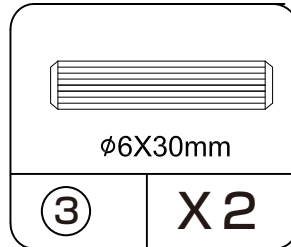
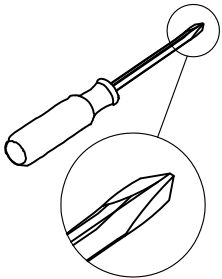
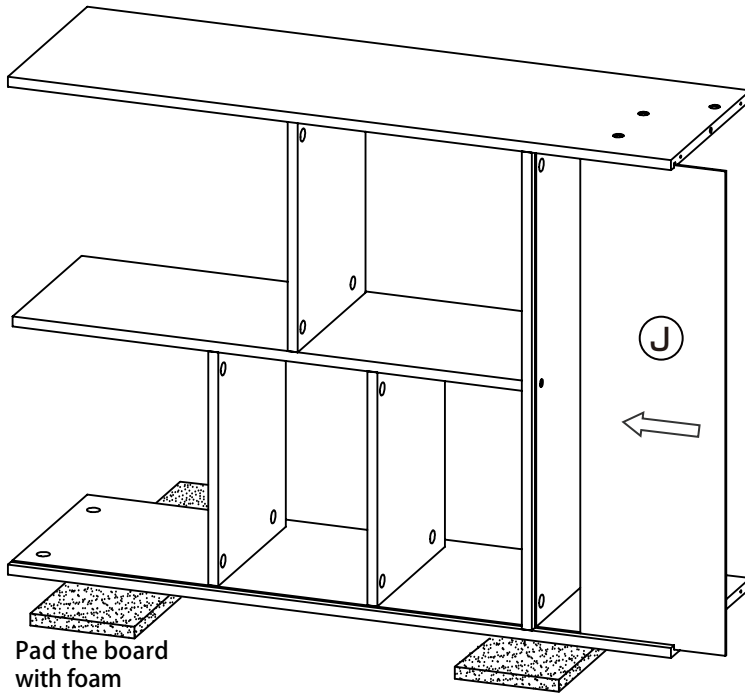

STEP 5

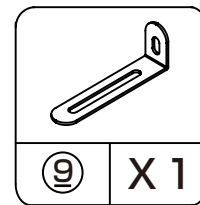
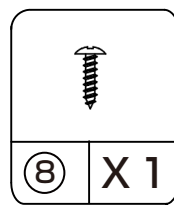
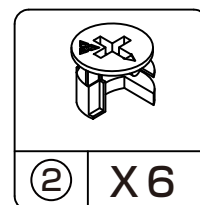
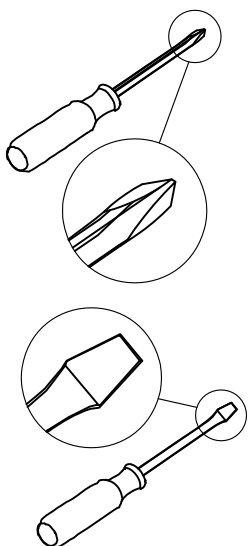
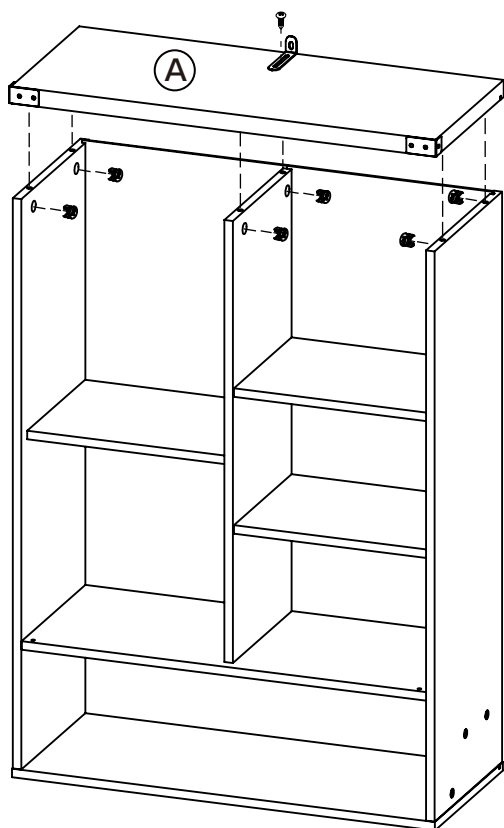
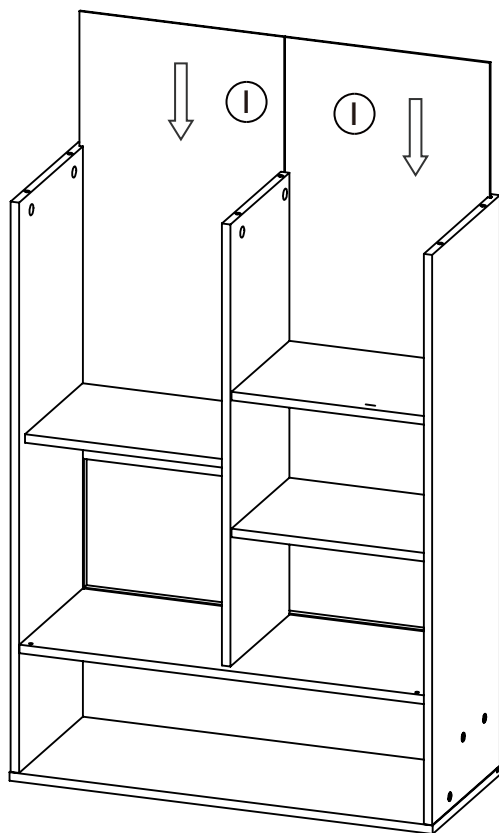

STEP 6

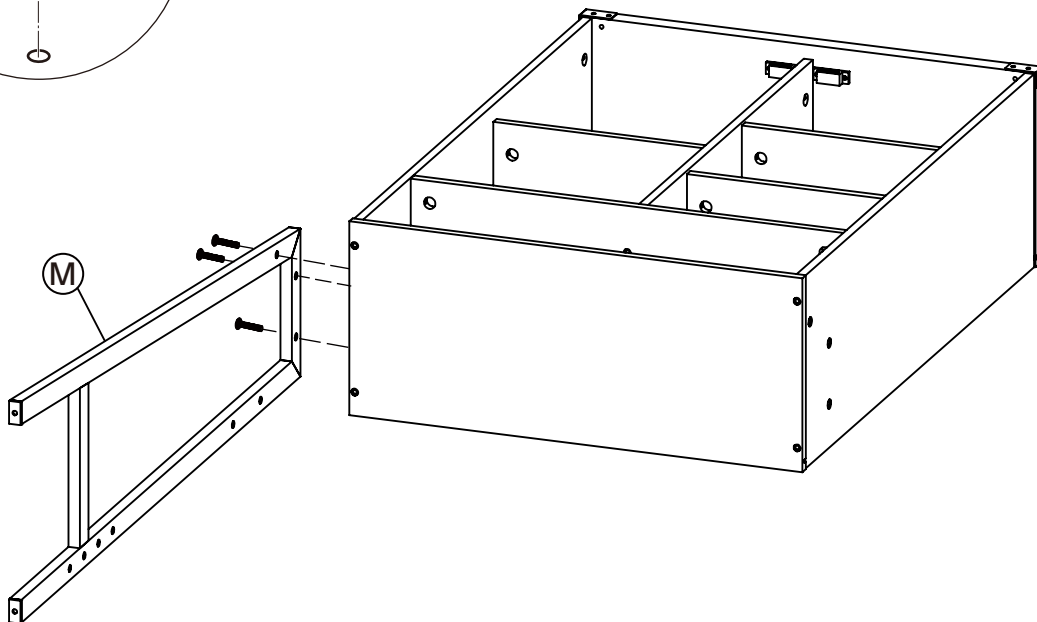
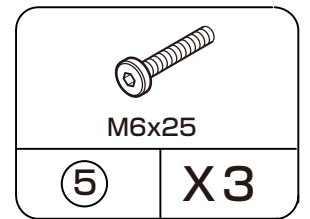
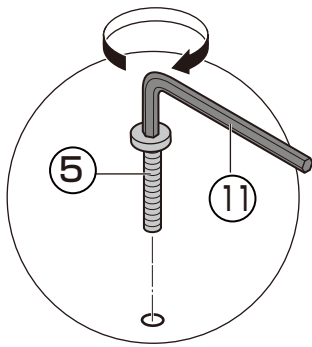
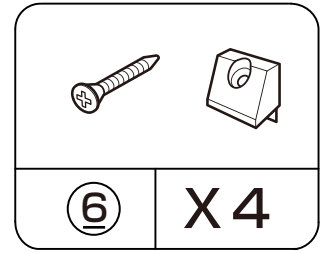
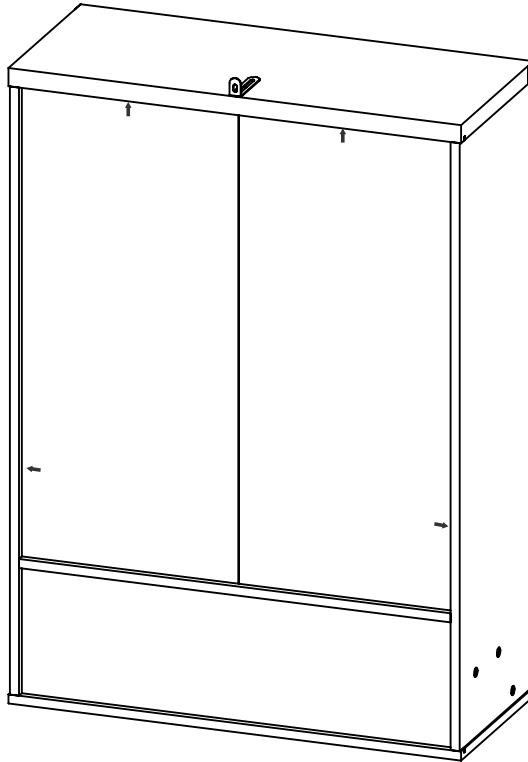
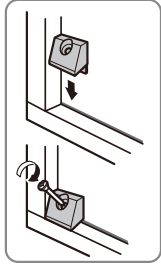
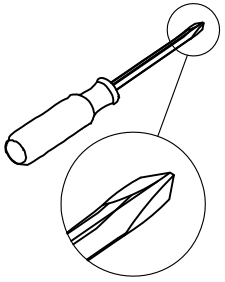

STEP 7

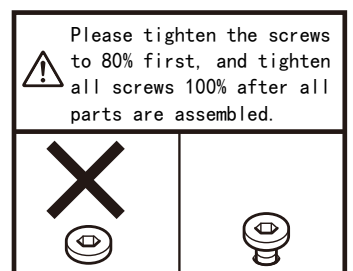
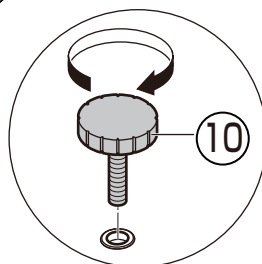
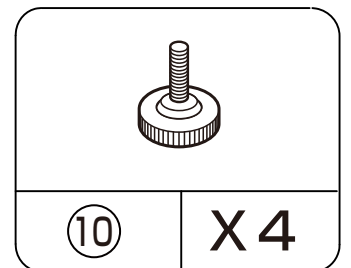
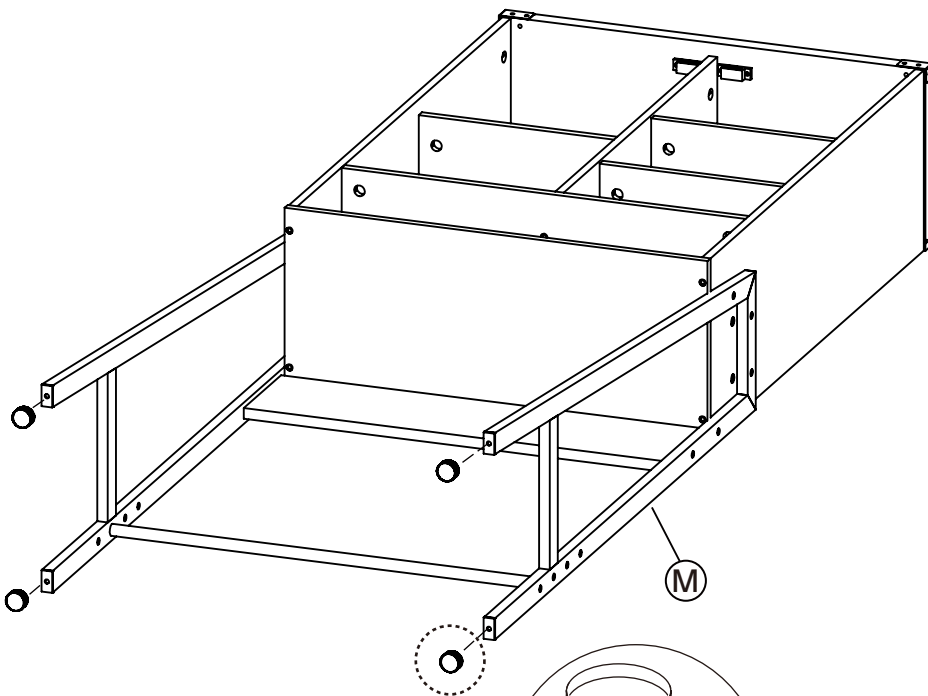
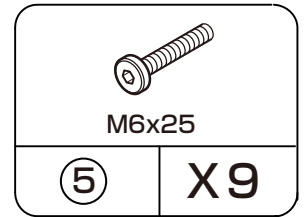
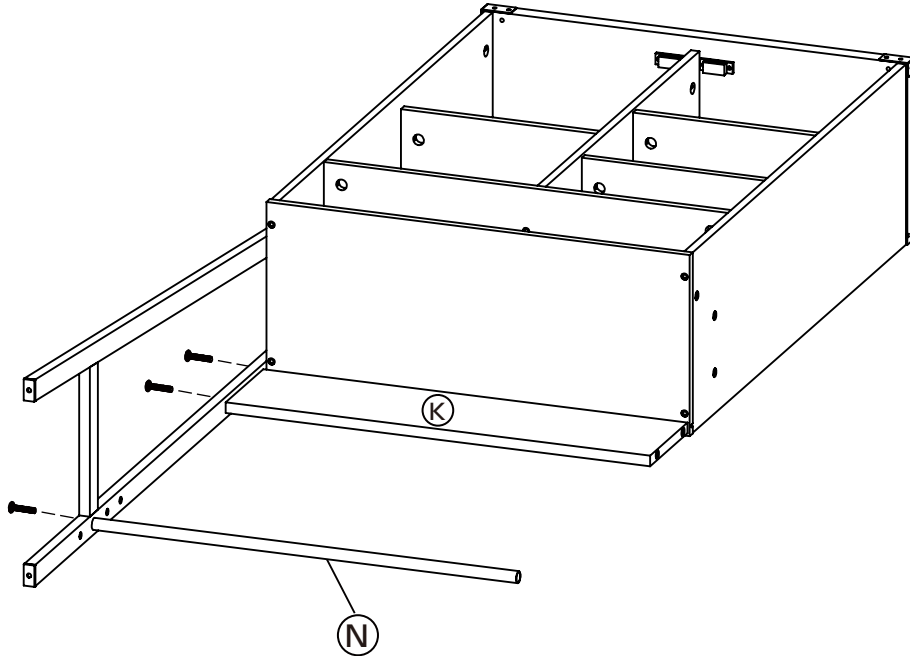

STEP8

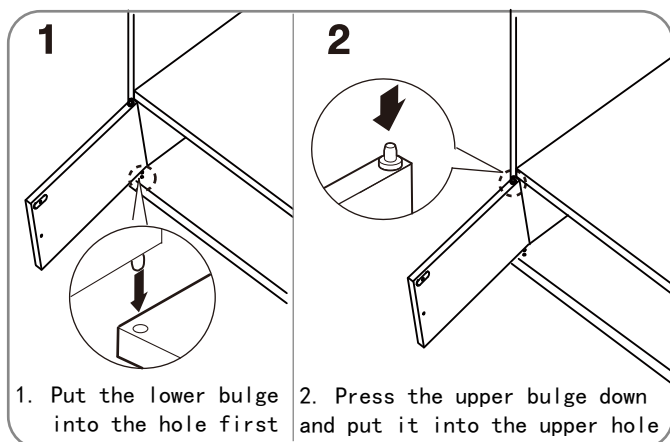

Note: When installing the door, you need to keep the door suction plate on the top to ensure that the iron sheet can attract the magnet.

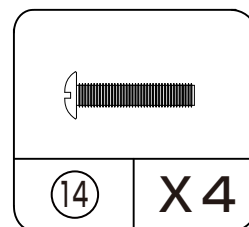
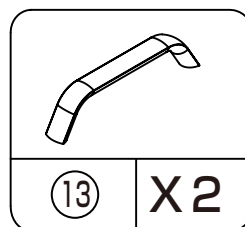
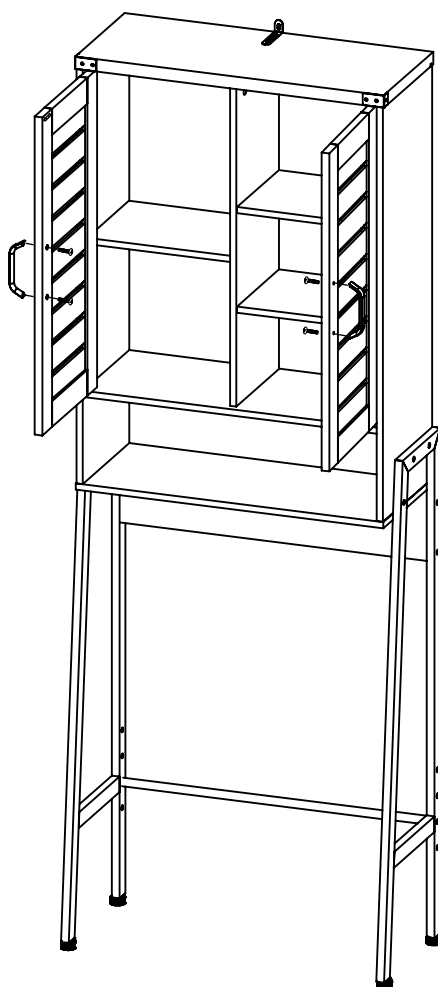
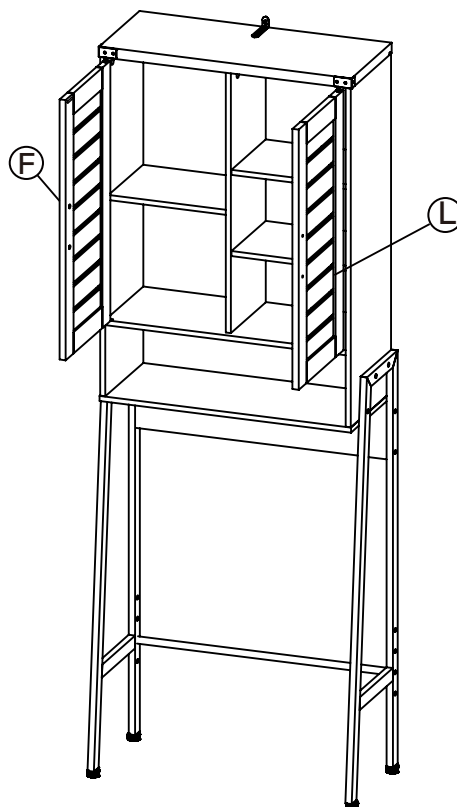

STEP9

