

D8L241HS02/D8L241BR02

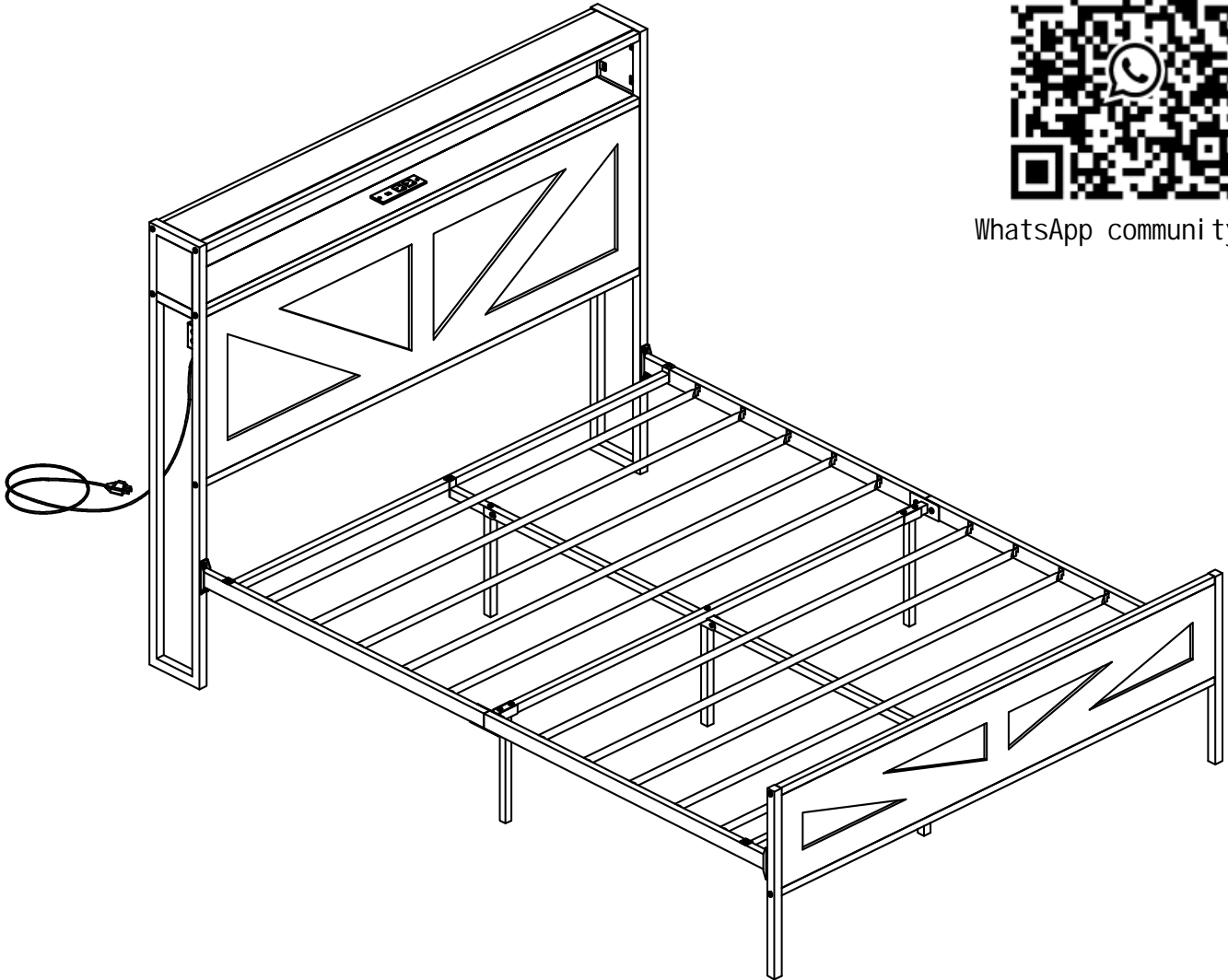

WhatsApp community ↑



As this item contains many parts, please read the installation instruction carefully before installation and complete the installation with the cooperation of your partner. Please use tools properly and carefully. If you have any questions about the product and installation, please contact us.

service@vabchesofficial.com

Our professional after-sales team will serve you online all day.

Before You Start

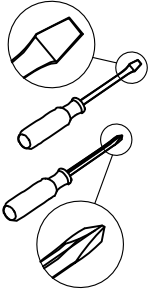

- ✓ Read through each step carefully and follow the proper order
- ✓ Separate and count all your parts and hardware
- ✓ Give yourself enough room for the assembly process
- ✓ Have the following tools: Flat Head Screwdriver, #2 Phillips Head Screwdriver
- ✓ Caution: If using a power drill or power screwdriver for screwing, please be aware of to slow down and stop when screw is tight. Failure to do so may result in stripping the screw.

Helpful Hints





PEOPLE NEEDED FOR ASSEMBLY: 1-2

- Open your item in the area you plan to keep it to avoid excessive heavy lifting.
- Identify, sort and count the parts before attempting assembly.
- Do NOT use harsh chemicals or abrasive cleaners on this item.
- Never push, pull, or drag your furniture.

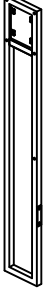

Parts Identification

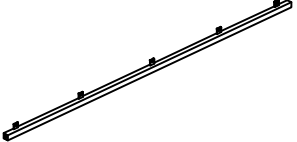
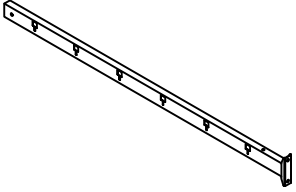
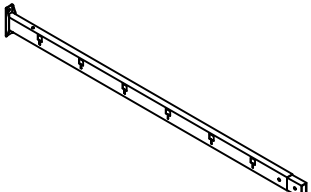
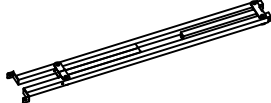
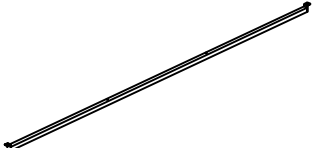
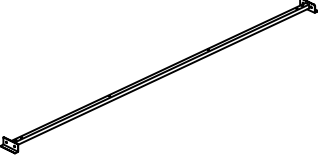
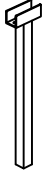
Not actual size

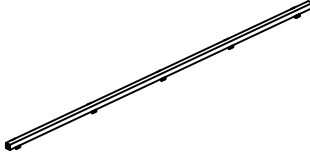
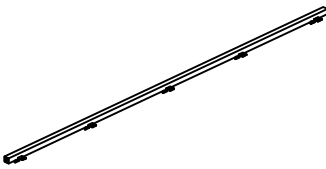
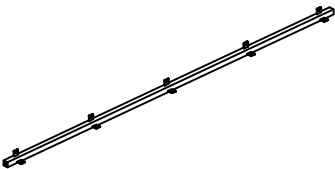
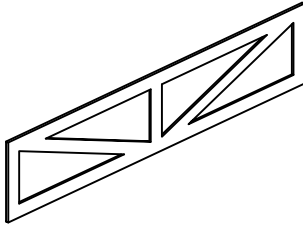
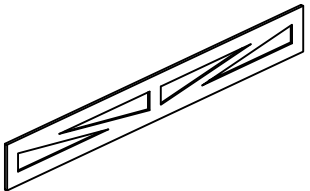
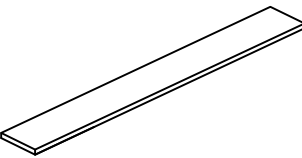
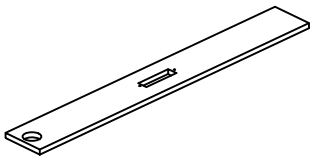
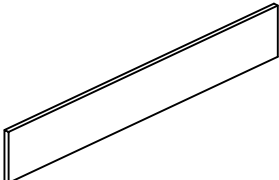
 Ⓐ x 1	 Ⓑ x 1	 Ⓒ x 2	 Ⓓ x 4
 Ⓔ x 2	 Ⓕ x 2	 Ⓖ x 1	 Ⓗ x 2
 Ⓘ x 1	 Ⓙ x 2	 Ⓚ x 12	 Ⓛ x 1
 Ⓜ x 1	 Ⓝ x 1	 Ⓞ x 1	 Ⓟ x 1
 Ⓠ x 1	 Ⓡ x 1	 Ⓢ x 1	

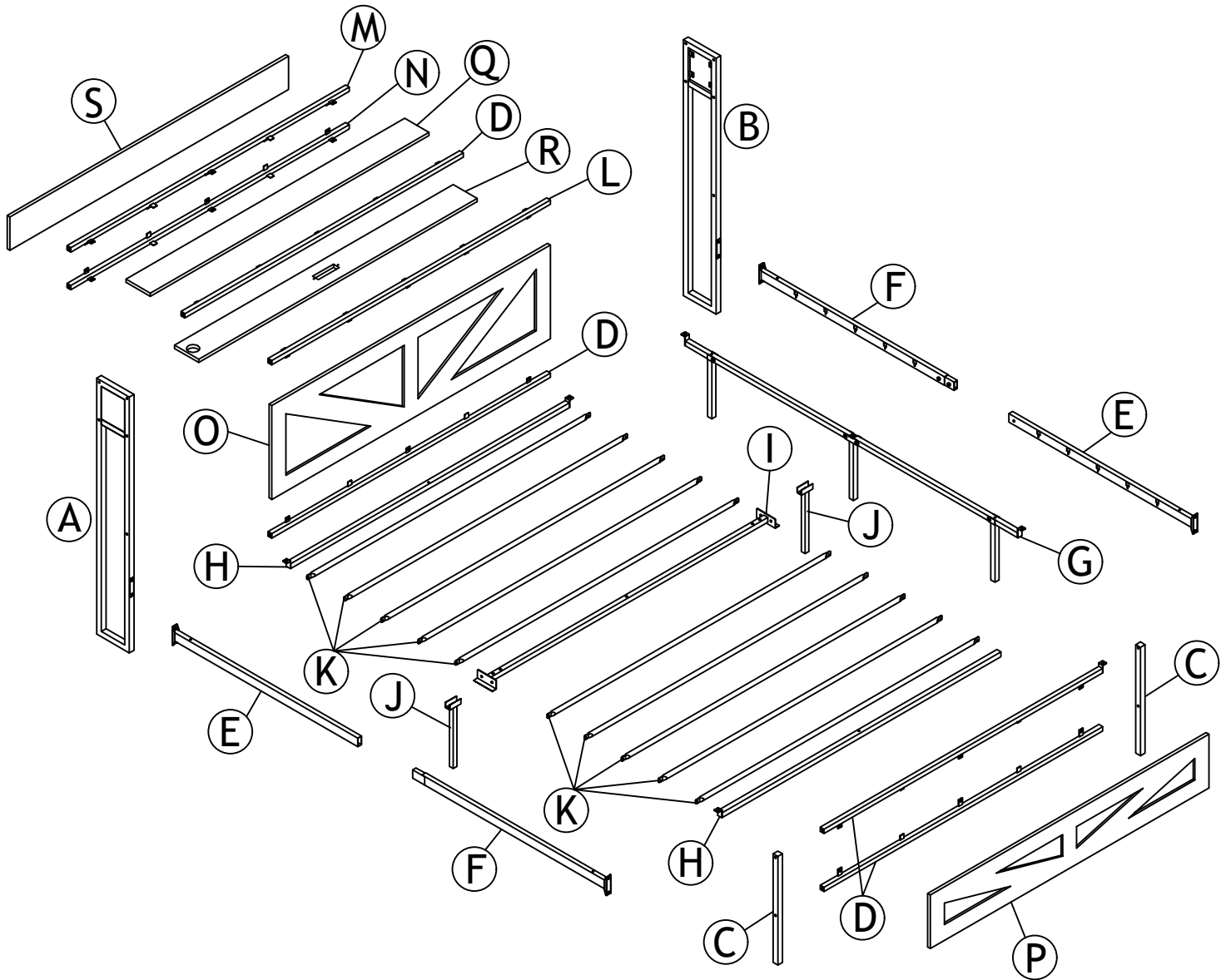

Parts Identification

Not actual size

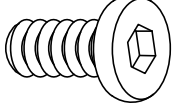
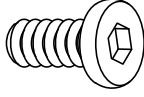
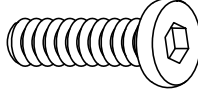
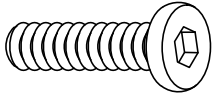

Hardware List

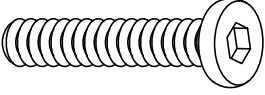
<p>BOLT</p>  <p>M8 x 13mm</p> <p>① x 4</p> <p>spare: 1</p>	<p>BOLT</p>  <p>1/4" x 13mm</p> <p>② x 44</p> <p>spare: 3</p>	<p>BOLT</p>  <p>1/4" x 25mm</p> <p>③ x 4</p> <p>spare: 1</p>	<p>BOLT</p>  <p>1/4" x 35mm</p> <p>④ x 2</p> <p>spare: 1</p>
---	--	--	---

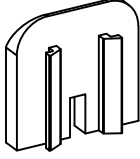
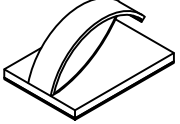
<p>BOLT</p>  <p>1/4" x 50mm</p> <p>⑤ x 15</p> <p>spare: 2</p>	<p>SCREW</p>  <p>Ø3.5 x 15mm</p> <p>⑥ x 9</p> <p>spare: 1</p>	<p>Plastic buckle</p>  <p>⑦ x 20</p> <p>spare: 3</p>	<p>WIRE CLIP</p>  <p>⑧ x 2</p>
--	--	--	---

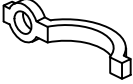
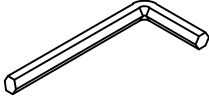
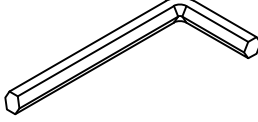
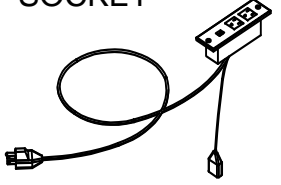
<p>LED STRIP CLIPS</p>  <p>⑨ x 7</p>	<p>ALLEN KEY</p>  <p>M4</p> <p>⑩ x 1</p>	<p>ALLEN KEY</p>  <p>M5</p> <p>⑪ x 1</p>	<p>SOCKET</p>  <p>⑫ x 1</p>
---	---	--	--

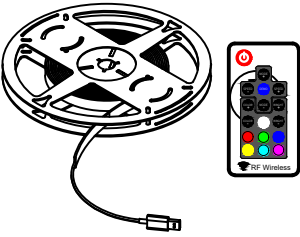
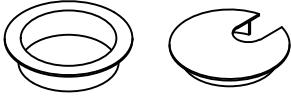
<p>LED STRIP</p>  <p>⑬ x 1</p>	<p>CABLE HOLE COVER</p>  <p>x 1</p>
---	--

STEP 1

Pls do not tighten all bolts until the bed is assembled completely

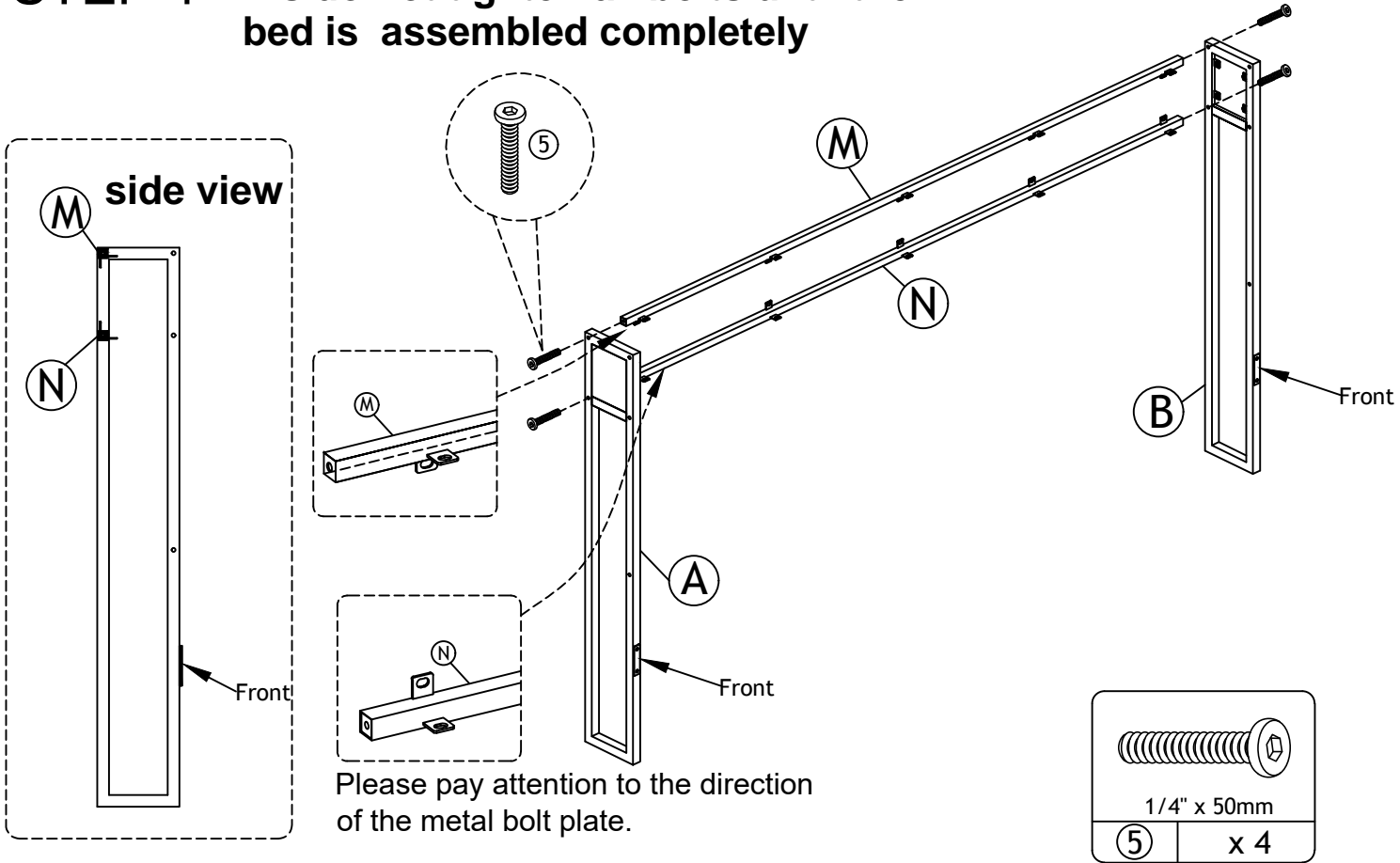

STEP 2

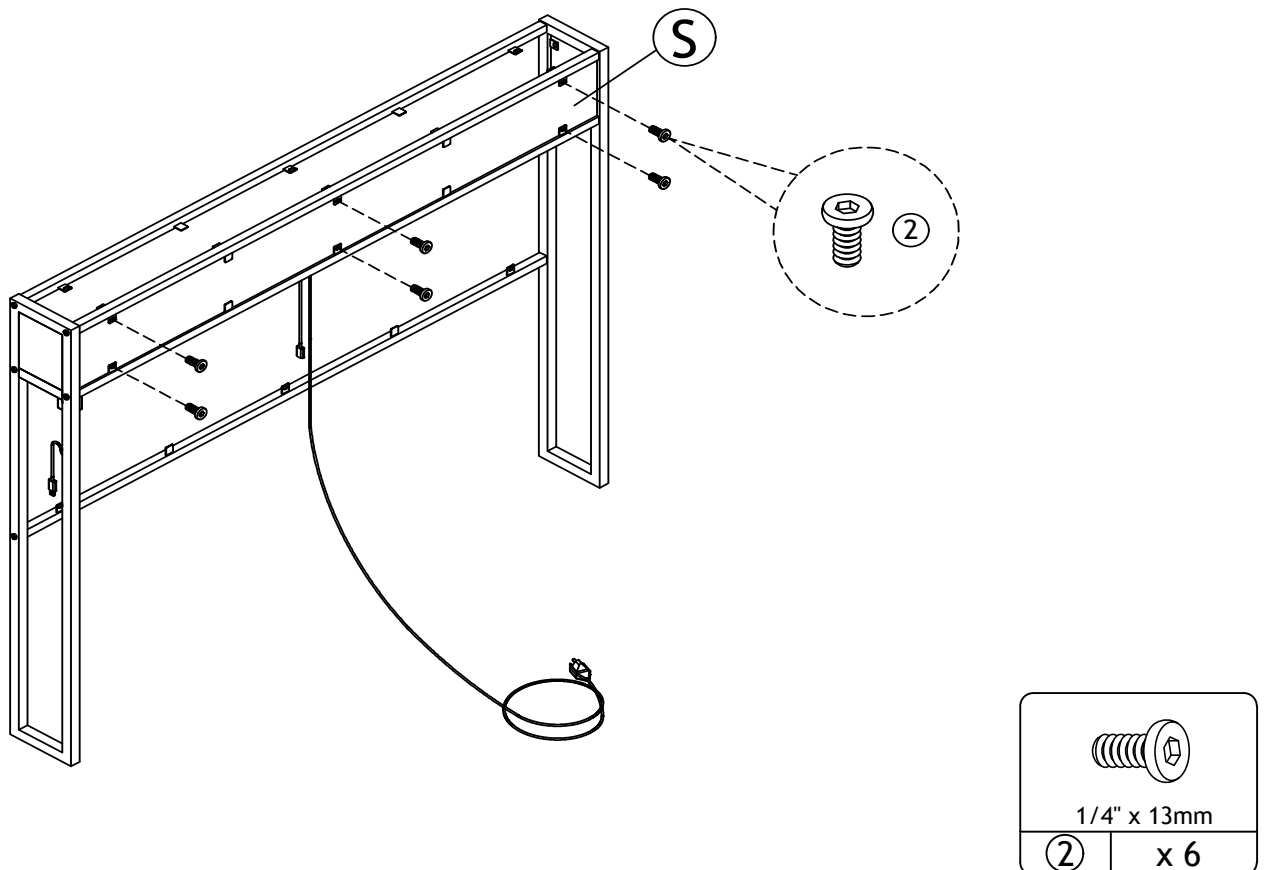

STEP 3

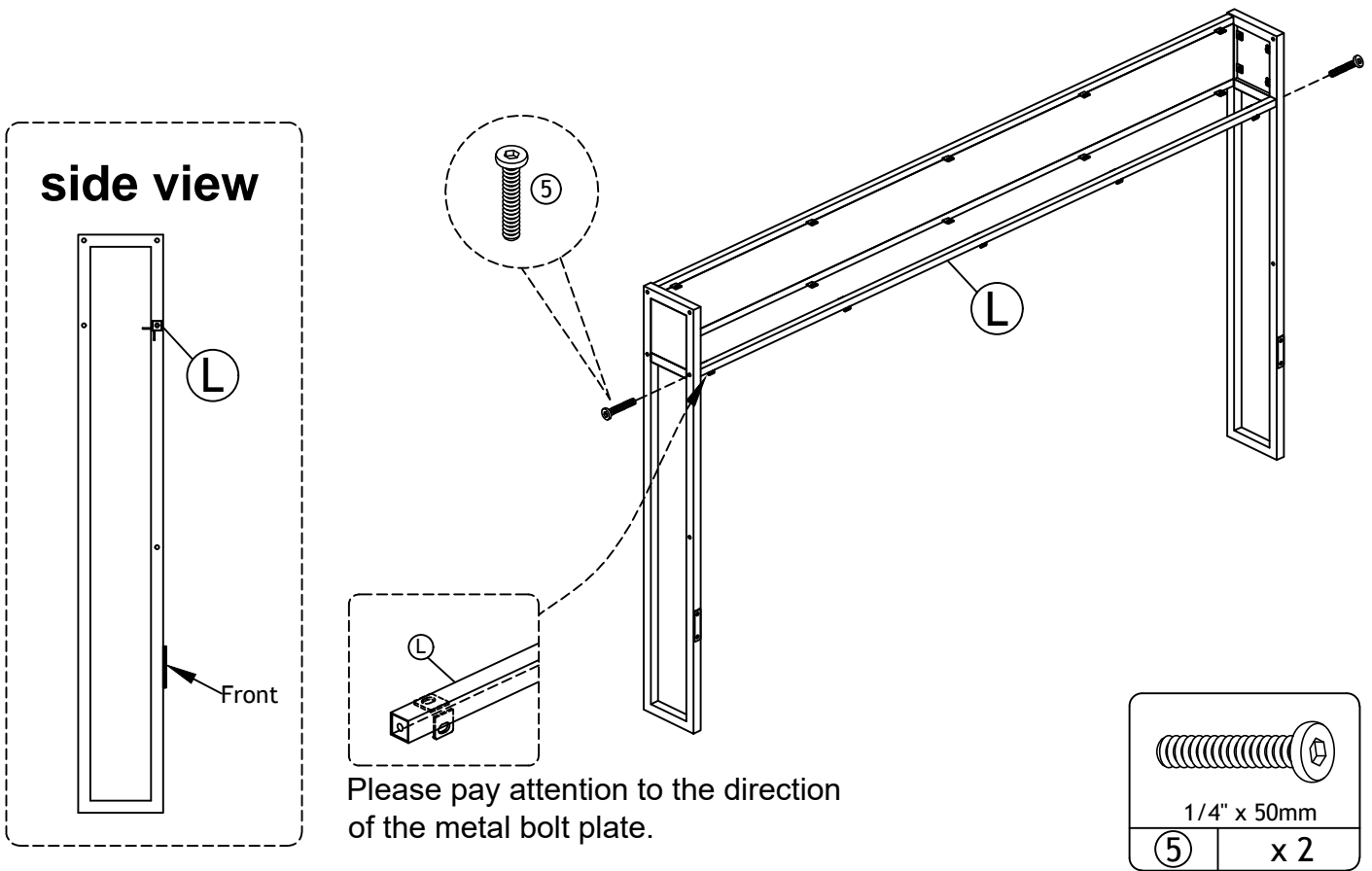

STEP 4

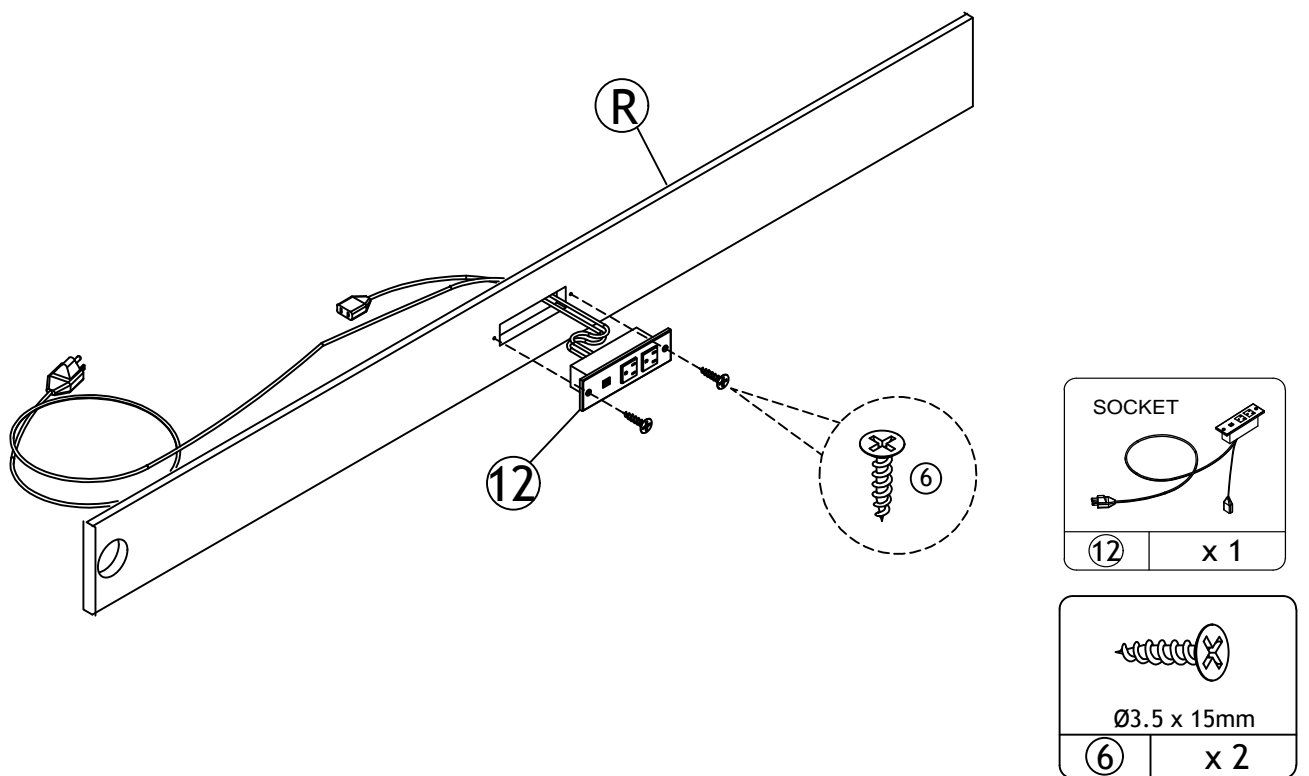

STEP 5

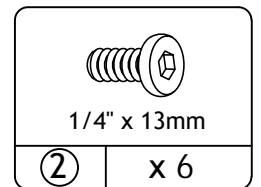
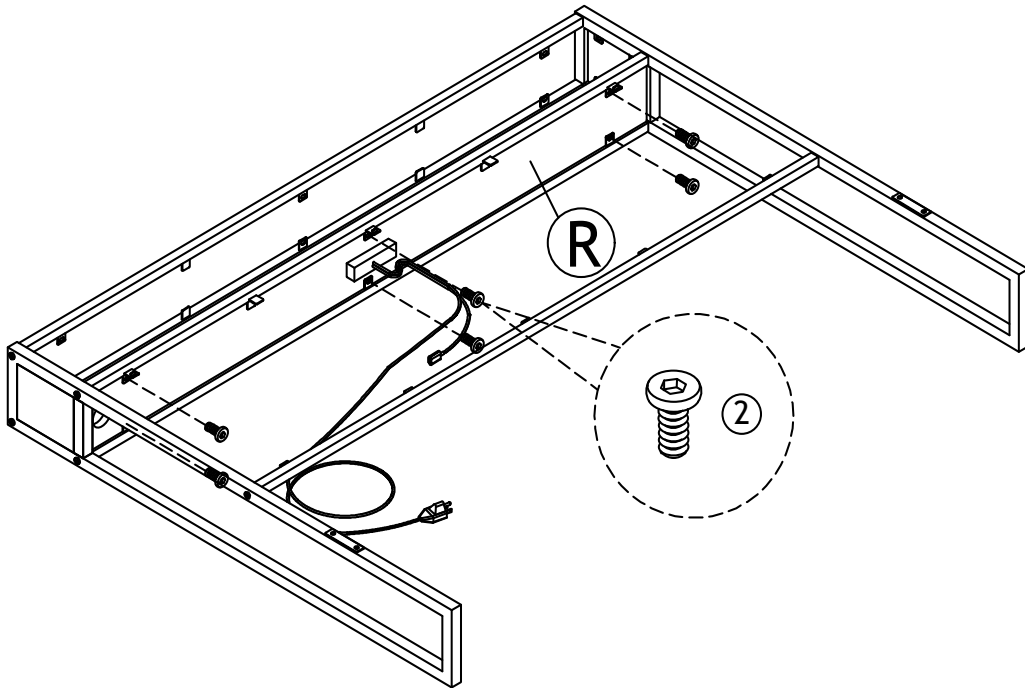

STEP 6

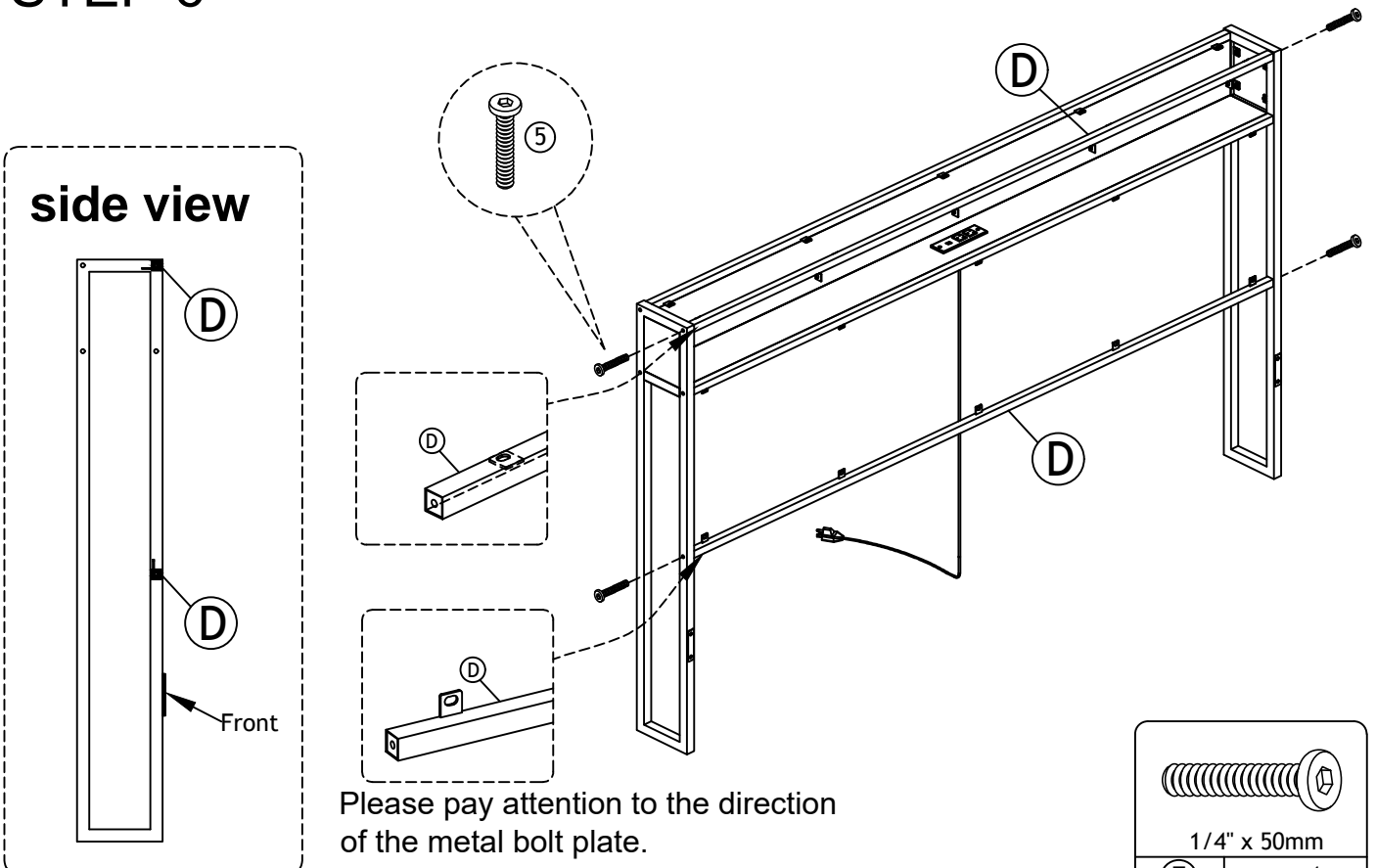

STEP 7

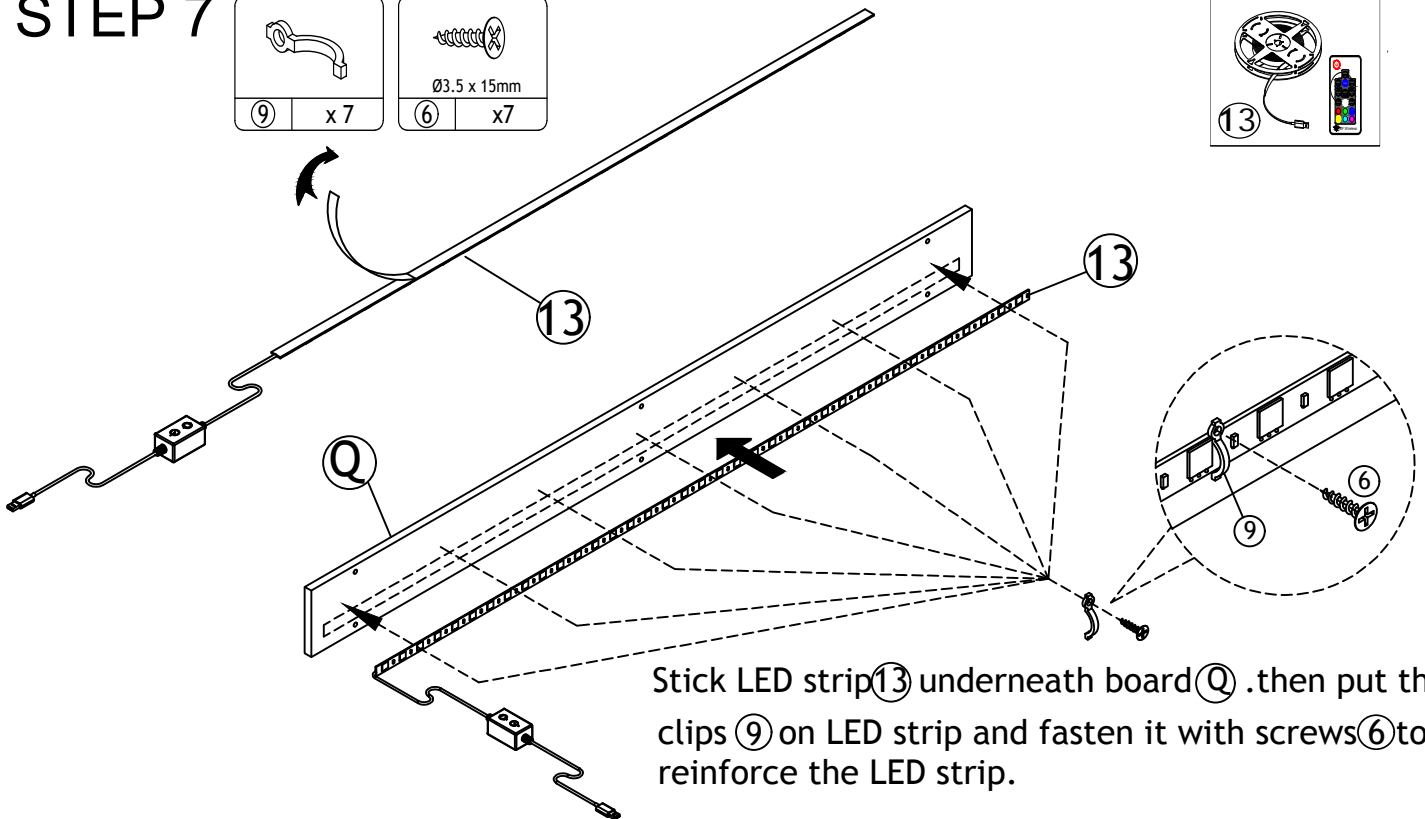
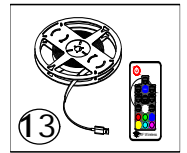
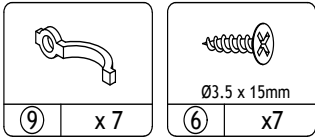

Stick LED strip ⑬ underneath board ①. then put the clips ⑨ on LED strip and fasten it with screws ⑥ to reinforce the LED strip.

THE 2 ENDS OF LED STRIP MUST TO BE REINFORCED BY LED STRIP CLIPS ⑨

There are no screw holes on board (Q), you can choose suitable positions to fix the clips with screws.

STEP 8

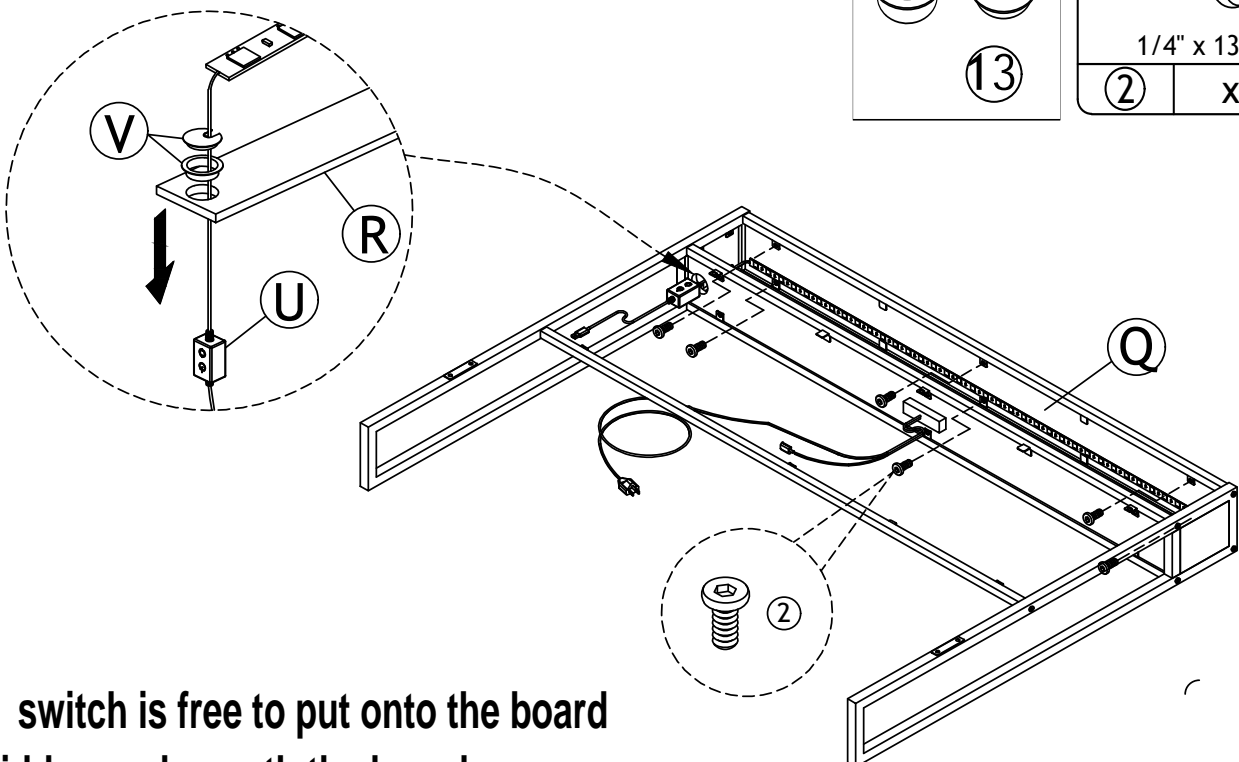
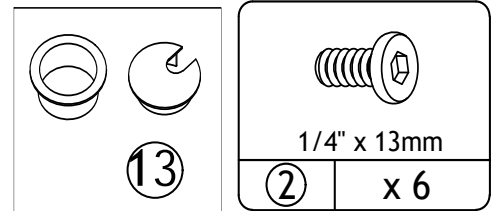

The switch is free to put onto the board or hidden underneath the board.

STEP 9

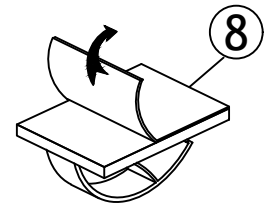
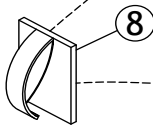
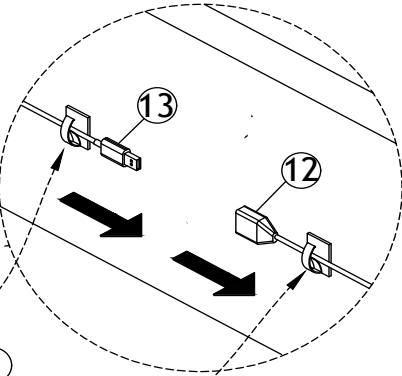
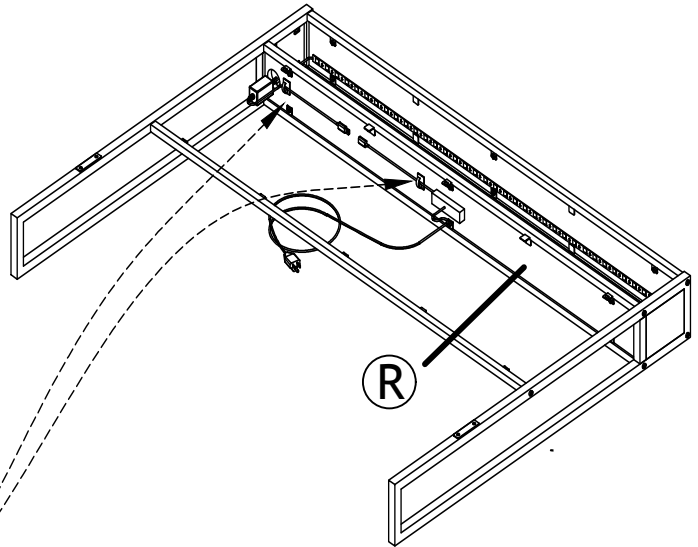
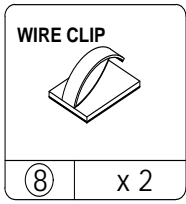

Connect lamp strip usb, usb adapter and socket ⑫ . stick clip ⑧ underneath board ⑨ . Then buckle the lines.

STEP 10

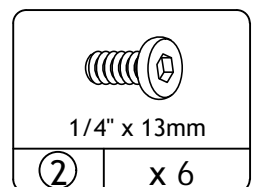
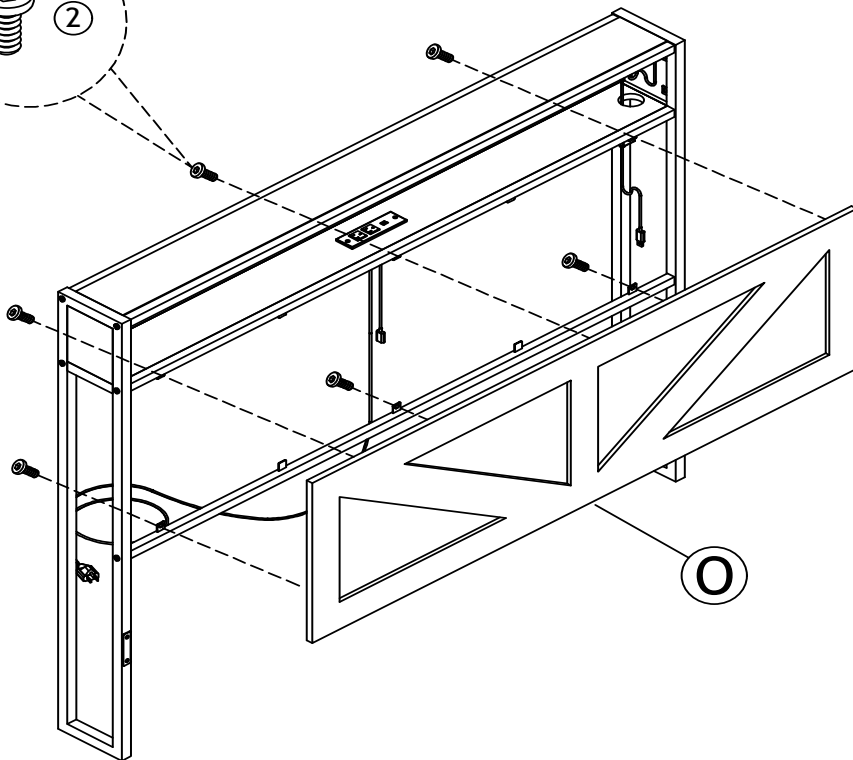
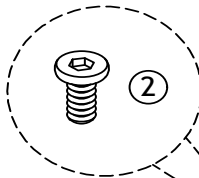

STEP 11

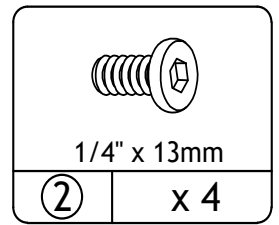
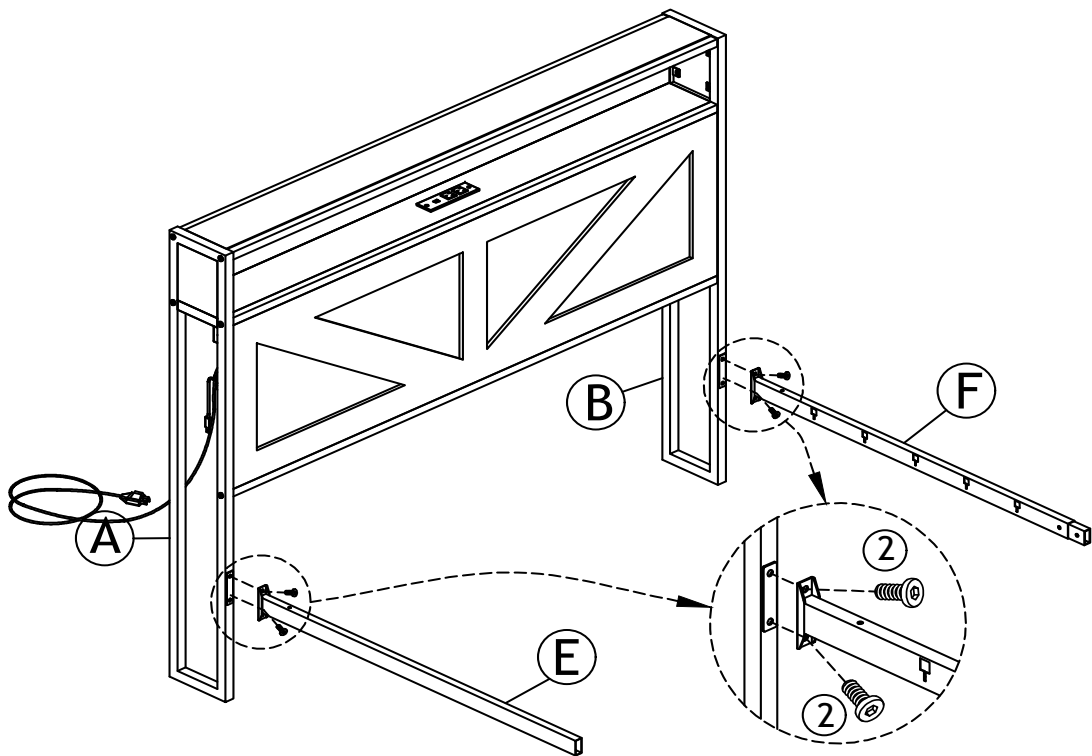

STEP 12

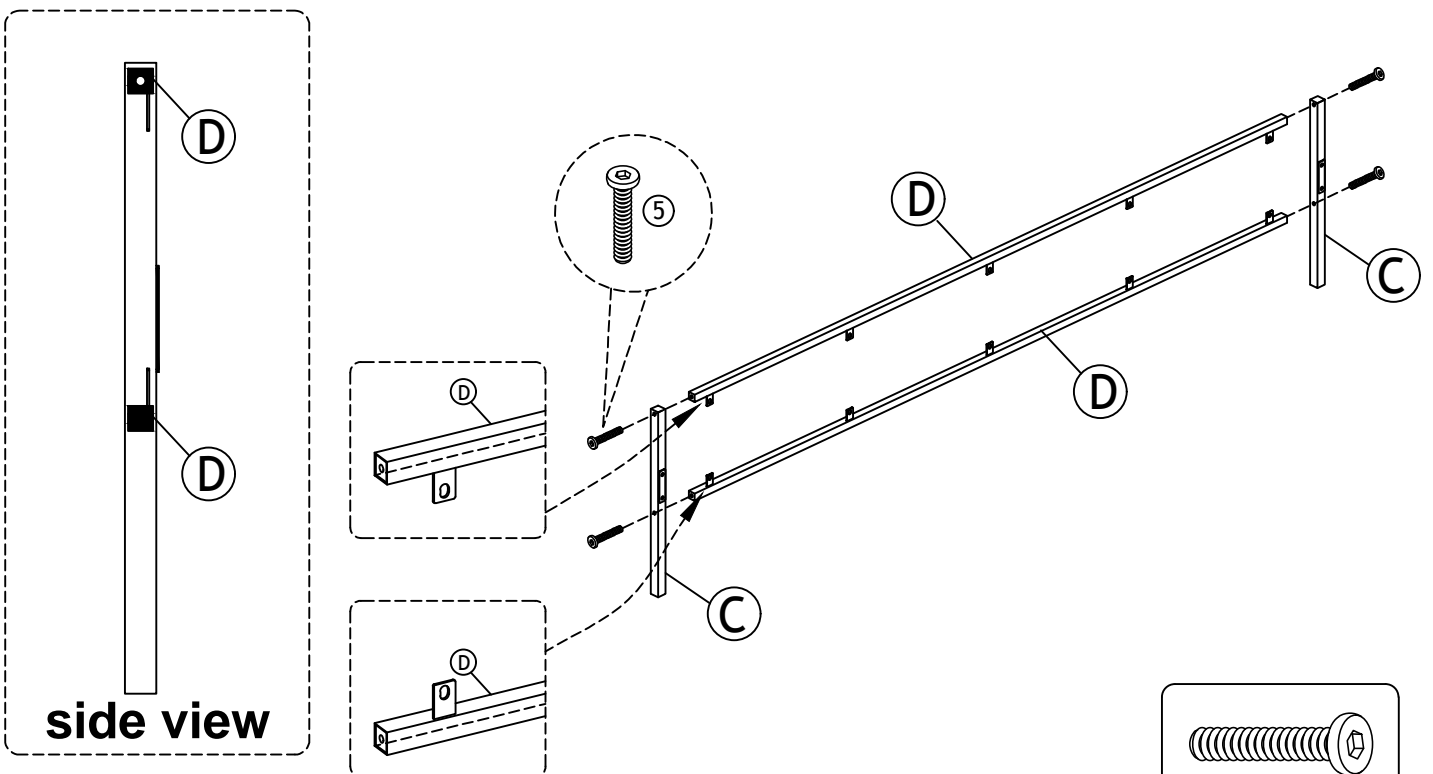

side view

Please pay attention to the direction of the metal bolt plate.

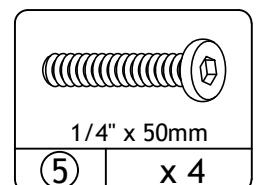

STEP 13

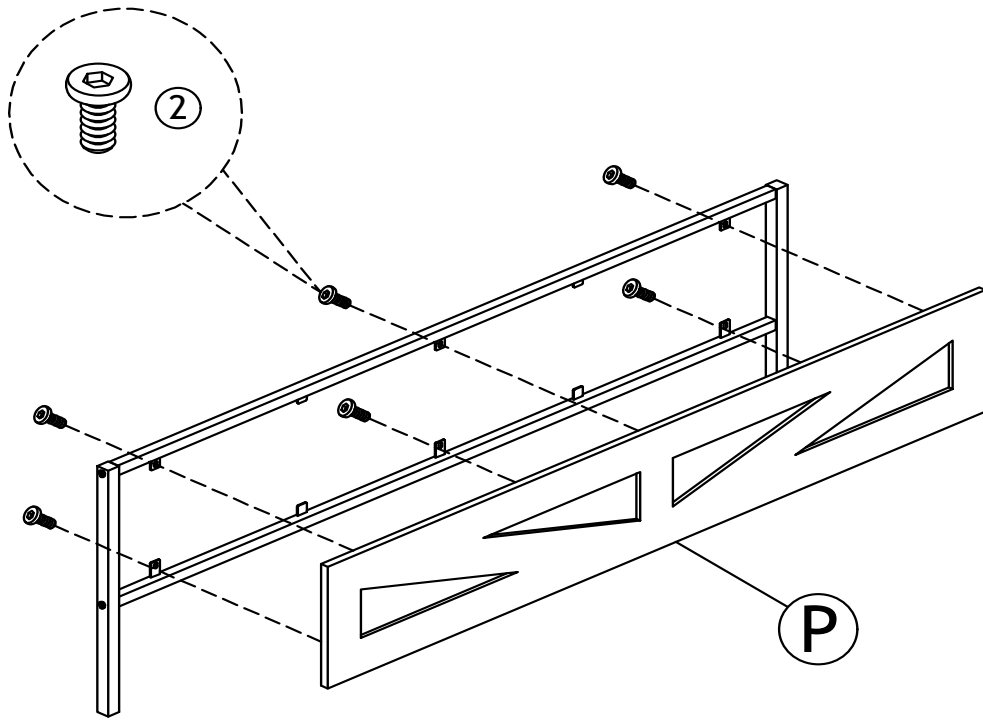

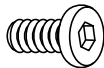
	
1/4" x 13mm	
②	x 6

STEP 14

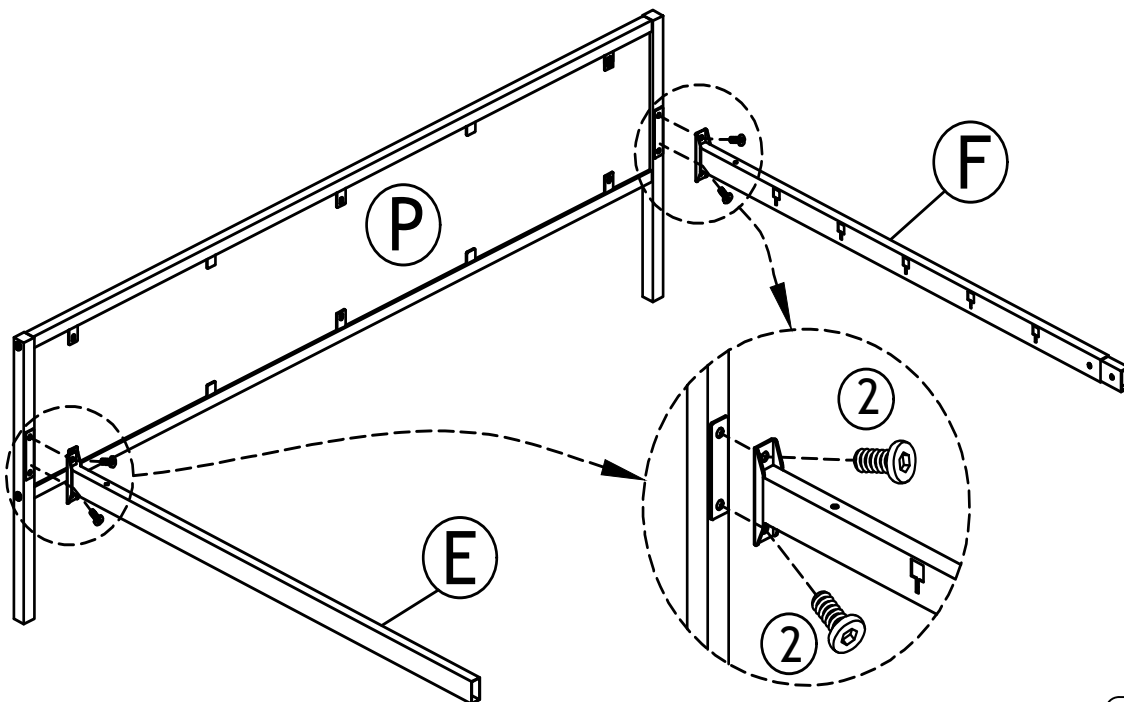

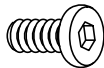
	
1/4" x 13mm	
②	x 4

STEP 15

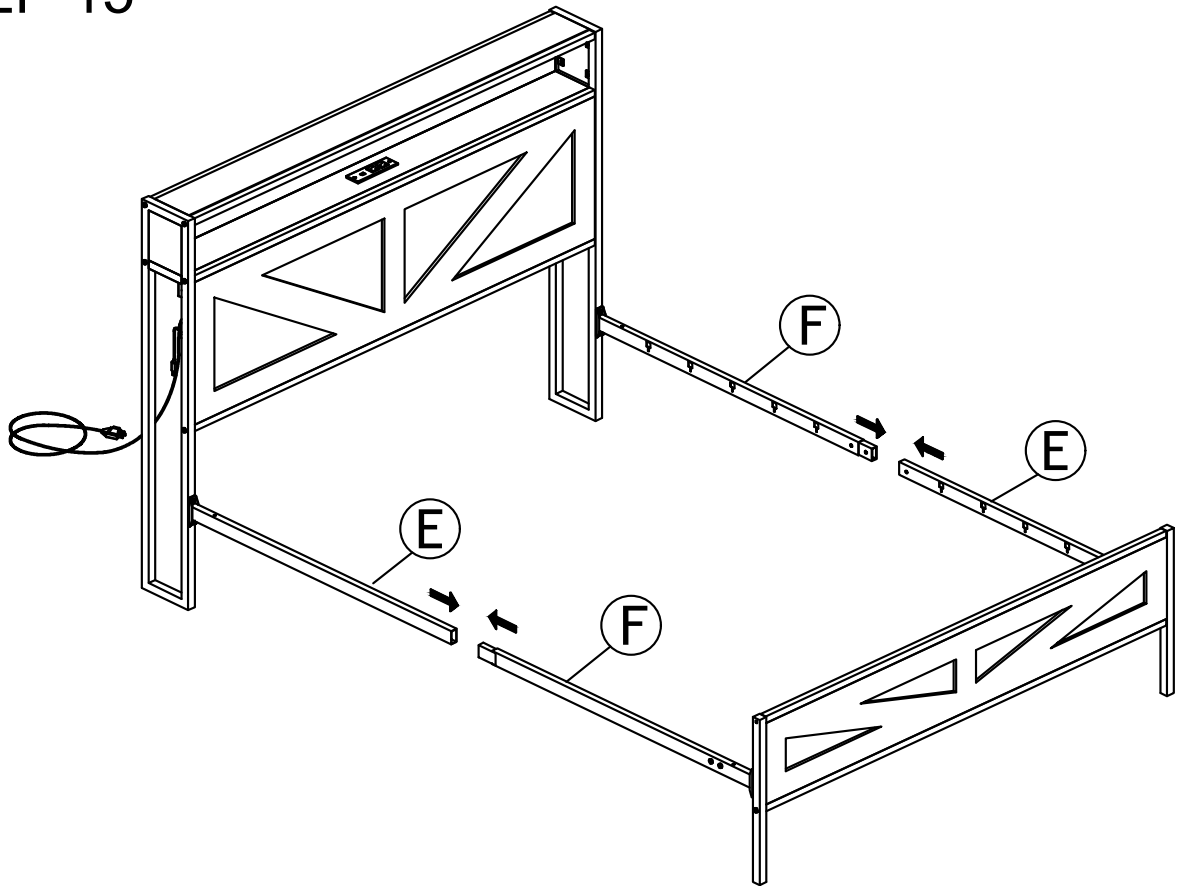

STEP 16

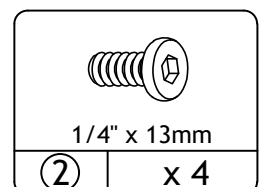
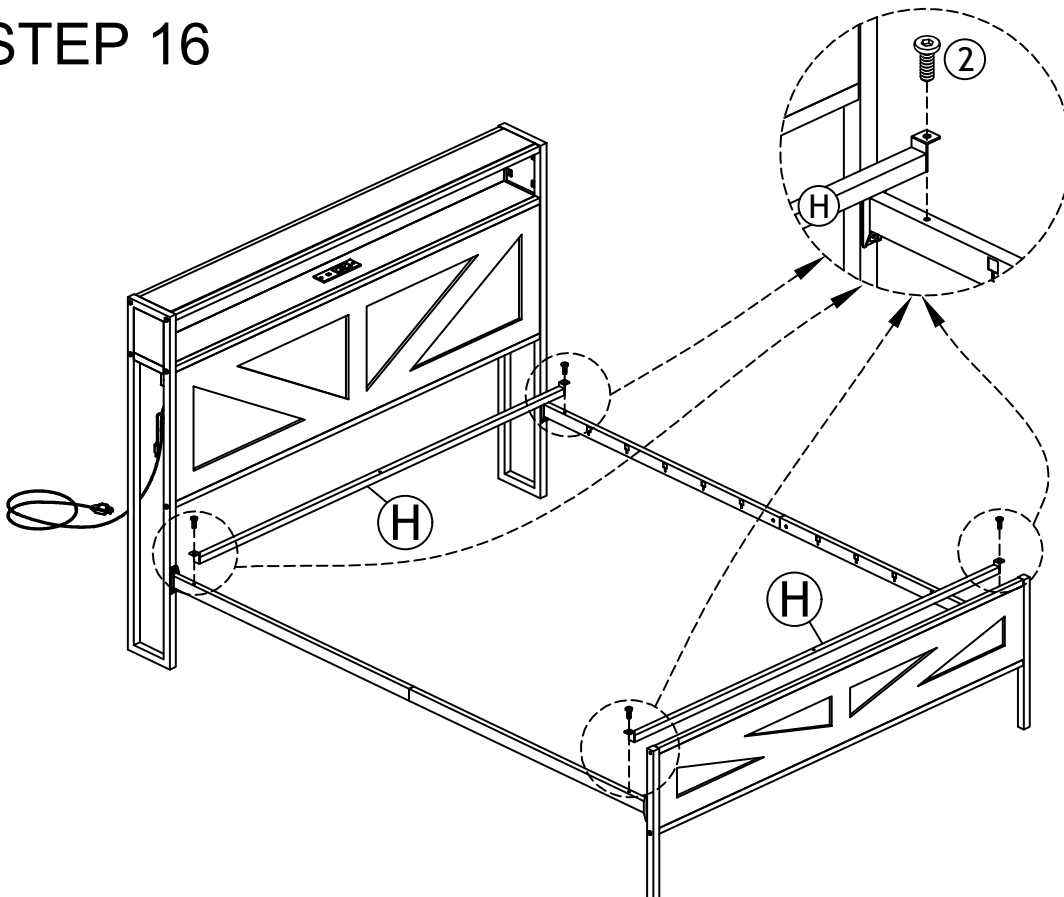

STEP 17

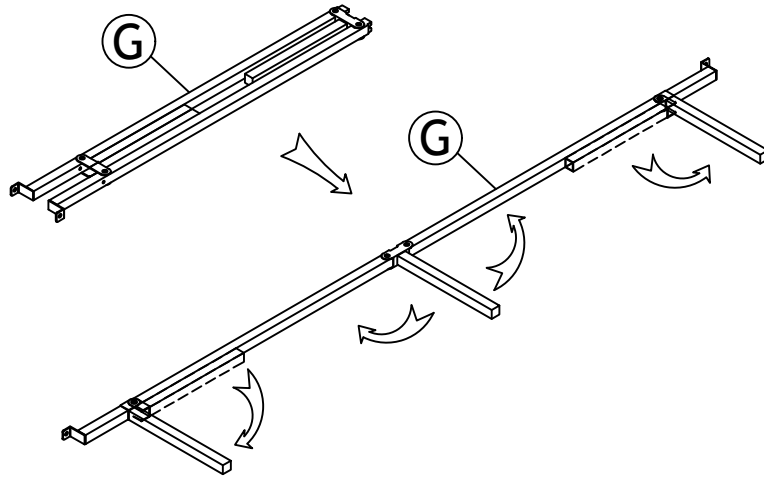

Expand the folded portion

X 1

STEP 18

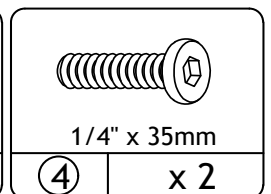
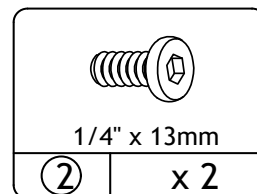
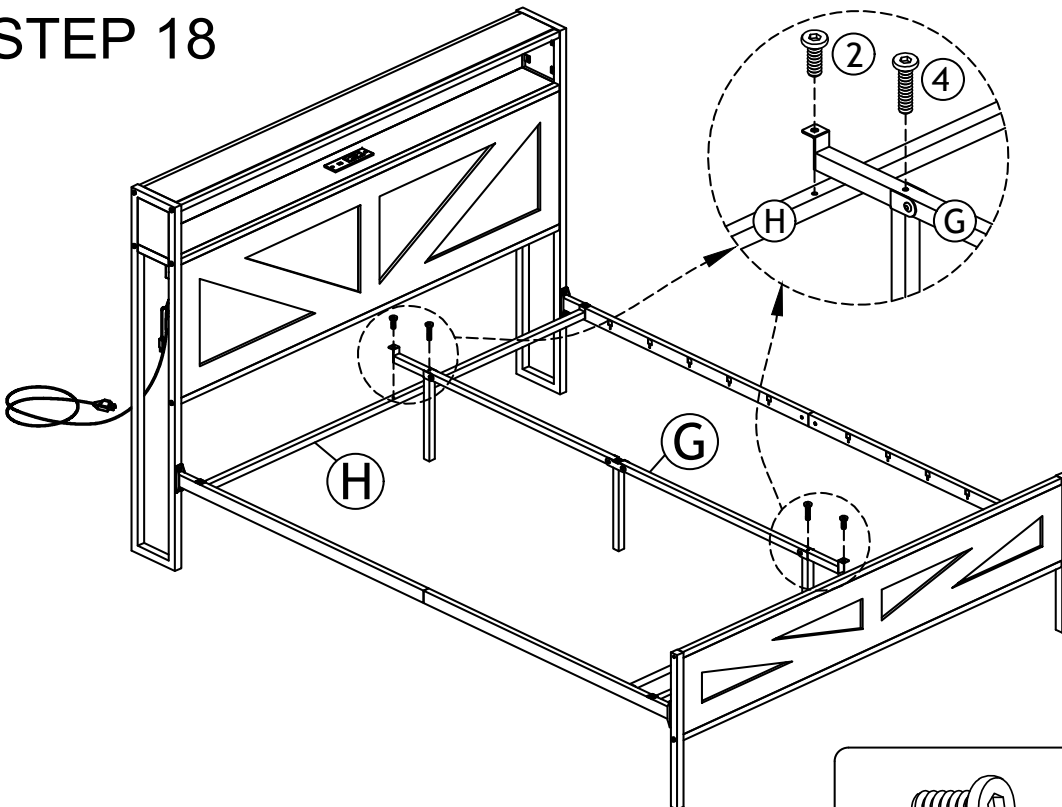

STEP 19

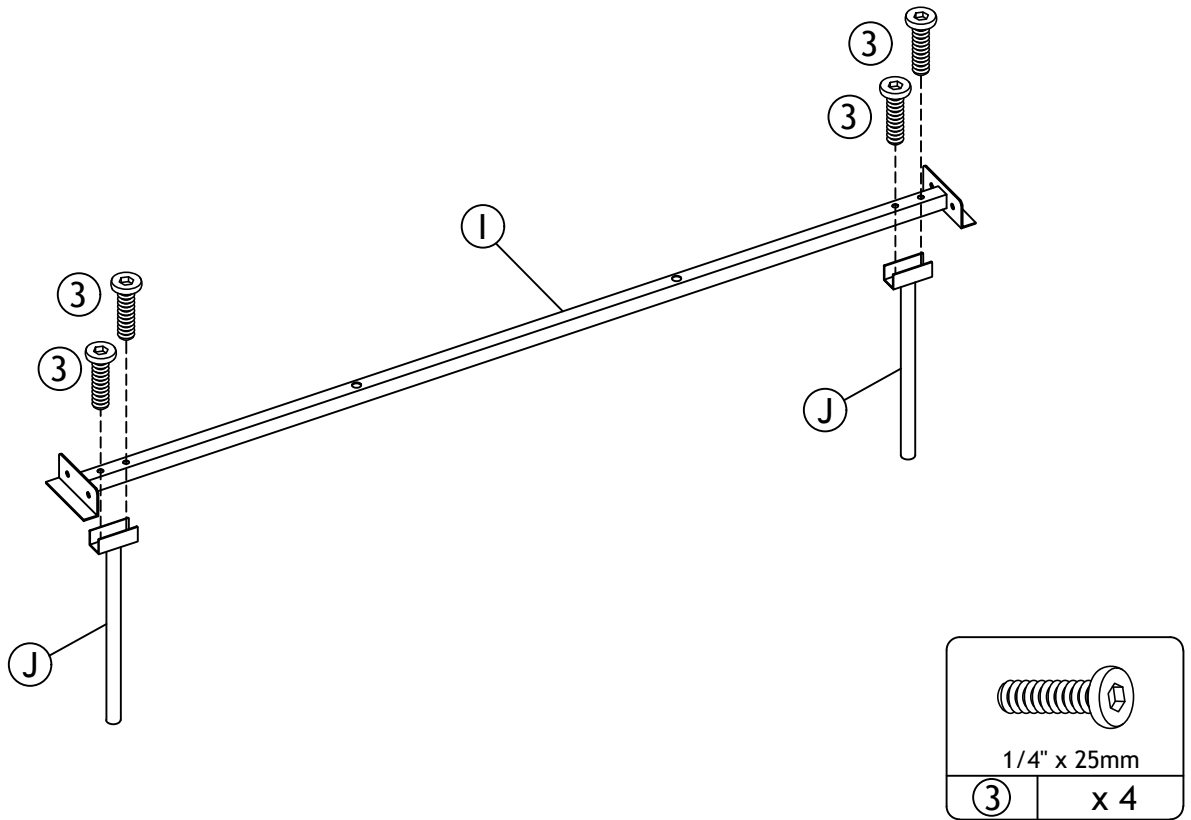

STEP 20

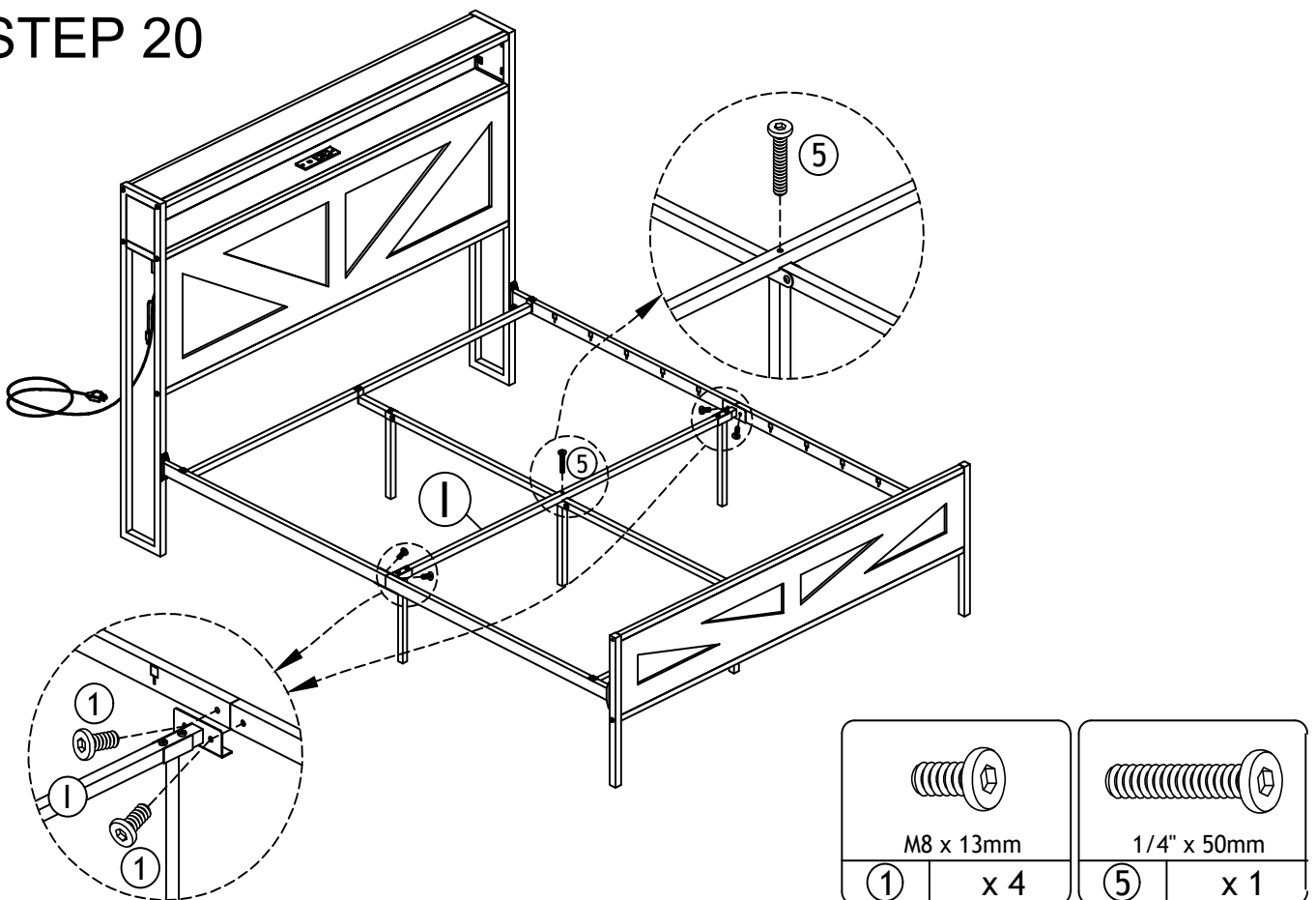

STEP 21

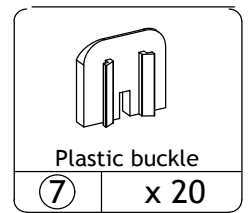
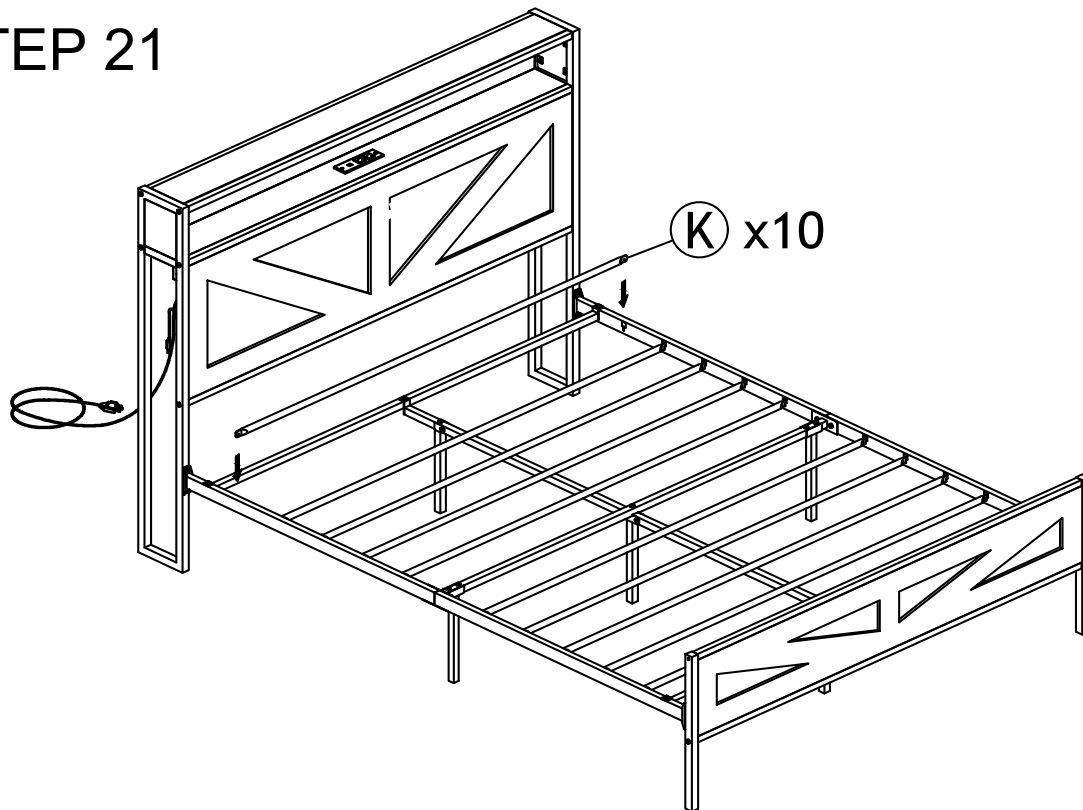

Assemble the slats

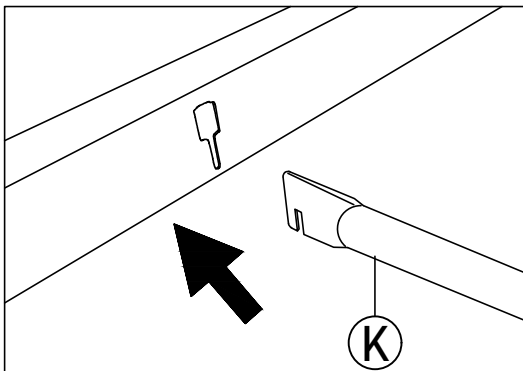

1. Insert slats into the hole on sidebar in the correct orientation.

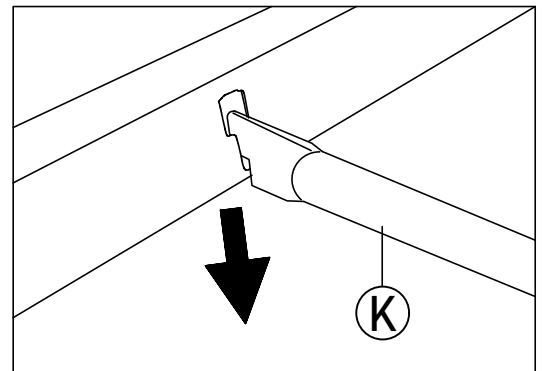

2. Push the slats into the gaps.

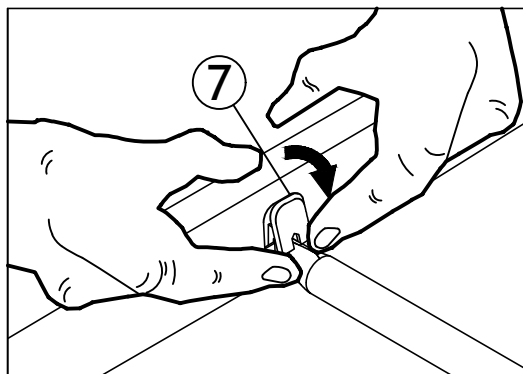

3. Put the plastic clamp(7) into the lower part of hole on 45 degree.

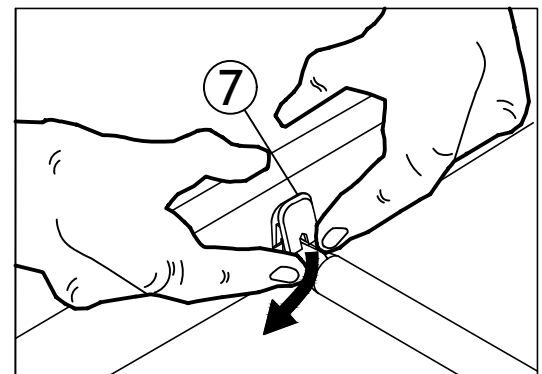

4. Press tight the upper part of clamp to fix its position.