

# XP

## START

- Turn on at wall
- Ensure the Upstand (1) is in place
- Check the Filter (2) and Scrap Trays (3) are in place
- Shut door and turn Cycle Selector to I, II or III
- Power light glows red and the machine will fill automatically

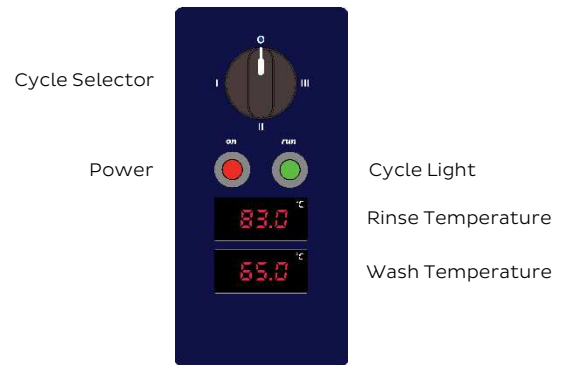

## OPERATION

- Select cycle of 1 (I), 2 (II), or 3 (III) minutes
- Load rack into machine and shut door
- Cycle light glows green while machine operates
- When the Cycle light goes out, the cycle is complete

NOTE: The machine may be started once the Wash light glows amber and the Rinse Ready light is off, however it will continue to run the wash cycle until the rinse water is up to temperature

## SHUT DOWN - EVERY NIGHT

- Turn Cycle Selector to 0
- Remove Scrap Trays (3)
- Remove Drain Upstand (1) only and allow the wash tank to drain
- Clean the tank then remove and rinse Filter (2) and Scrap Trays (3) before replacing back in machine with Upstand (1)

## CLEANING – AT LEAST ONCE A WEEK

Remove, rinse and replace:

Upstand	1
Filter	2
Scrap Trays	3
Wash/Rinse Arm	4

Inspect and clear all jets in the upper and lower Wash/Rinse Arms using a small object such as a toothpick where necessary to remove any blockages prior to rinsing

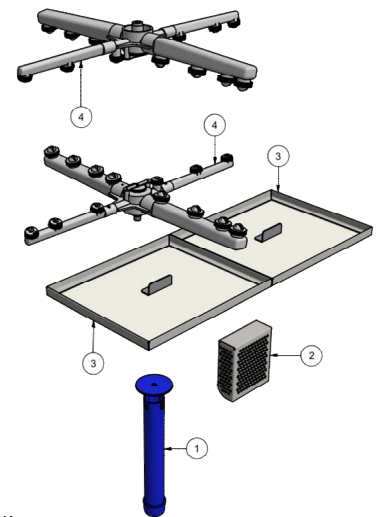

## SUGGESTED BEST PRACTICE

Cutlery	Stack with handles or sharp blades down and avoid overloading
Light Items	Ensure these are secured or weighted down by heavier items
Pre-rinse	Scrape and/or rinse plates & glasses in cool water
Chemical	Use good quality non foaming commercial detergent and drying agent – do not use domestic detergent which will cause the machine to foam
Wash results	If wash results are deteriorating, check that you have haven't run out of detergent and that the wash/rinse arms are clean and free of obstructions