

BANTAM

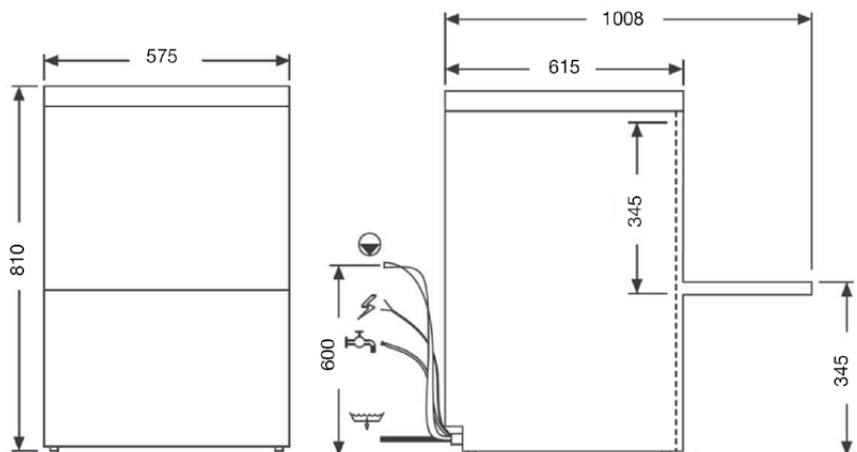

A compact commercial dishwasher suitable to use in residential commercial locations.

FEATURES

- **Warranty** – 3 years on the control board, 1 year parts and labour on the remainder of the machine
- 60/120/180 second cycles
- Up to 500 plates per hour*
- Automatic detergent injection
- Automatic drain (no stem pipe)
- 10amp power suitable for home
- Easy cleaning
- Recirculating wash system at 2.7L per cycle
- Pump out drain as standard

INCLUSIONS

- 1 x Flat rack insert 500mm x 500mm
- 1 x Plate rack insert 500mm x 500mm
- 1 x Cutlery container
- 1 x Water connection hose
- 1 x Drain hose
- 1 x Water connection hose
- 1 x Operating manual

TECHNICAL DATA

| | |
|---------------------|--------------|
| Height | |
| Cabinet | 810 mm |
| Cabinet inc. legs | 840 mm |
| Usable Wash | 345 mm |
| Width | |
| Cabinet | 575 mm |
| Depth | |
| Cabinet | 615 mm |
| With door open | 1008 mm |
| Capacities | |
| Loads/Hour | up to 20* |
| Water per Cycle | 2.7L* |
| Wash Pump | 500W |
| Wash Tank Litres | 20 |
| Boiler Tank Litres | 6 |
| Element (wash) | 1400W |
| Element (boiler) | 1500W |
| Detergent Injection | yes |
| Temperatures | |
| Wash Degrees C | 60 °C |
| Rinse Degrees C | 82 °C |
| Plumbing | |
| Drain | Pump out |
| Water | ¾" BSP (hot) |
| Electrical | |
| Volts/Hz | 240V AC/50Hz |
| Amps | 10amps |

* Subject to incoming water temperature + pressure

AUTHORISED DISTRIBUTOR