

# TMA

VACUUM CLEANER

# INSTRUCTION MANUAL

**Model: T120**

For any questions and malfunctions of the appliance during use, please contact our customer service email: [support@tmavacuum.com](mailto:support@tmavacuum.com)





# TABLE OF CONTENTS

IMPORTANT SAFETY INSTRUCTIONS - - - - -	01
WHAT'S IN THE BOX - - - - -	02
OVERVIEW - - - - -	03
ASSEMBLY - - - - -	04
SPECIFICATION - - - - -	04
OPERATING INSTRUCTIONS - - - - -	05
CLEANING AND MAINTENANCE - - - - -	07
CLEAR A CLOG - - - - -	10
TROUBLESHOOTING - - - - -	11
WARRANTY - - - - -	12

PLEASE KEEP THIS MANUAL FOR LATER MAINTENANCE OF  
THE MACHINE AND CONTACT US.

# IMPORTANT SAFETY INSTRUCTIONS

## IMPORTANT SAFETY INSTRUCTIONS

WHEN USING AN ELECTRIC APPLIANCES, BASIC PRECAUTIONS SHOULD ALWAYS BE FOLLOWED, INCLUDING THE FOLLOWING:

READ ALL INSTRUCTIONS BEFORE USING (THIS APPLIANCE)

**WARNING:** TO REDUCE THE RISK OF FIRE, ELECTRIC SHOCK, DAMAGE OR INJURY.

1. To protect against electrical shock, **do not** immerse power cord or plug in water or any other liquid. To avoid the risk of electrical shock or serious personal injury, always operate with dry hands.
2. Close supervision is necessary when any appliance is being used by or near children. This vacuum is not intended for use by persons (including children) with reduced physical, sensory or mental capabilities, or lack of experience and knowledge, unless they have been given supervision or instruction concerning the use of the vacuum by a person responsible for their safety.
3. **Do not** use the vacuum outdoors. It is for household use only.
4. **Do not** use the vacuum if it has been dropped, damaged, left outdoors, or dropped in water. Please contact customer service for help when the appliance or the adapter is damaged.
5. Use the vacuum only as described in this manual. The use of accessory attachments not recommended may cause damage to the vacuum or personal injuries.
6. **Do not** use abrasive materials to clean the vacuum. **Do not** use spirits or other solvents to clean the appliance.
7. **Do not** use the appliance to vacuum all the below things:
  - Water, flammable or combustible liquids such as gasoline;
  - Lighted stub, matches, hot ashes and other combustible things;
  - Needles, pins and other sharp things;
  - Wood pieces, gesso, cement, calcimine and other tiny granules;
  - Pieces of string or fabrics.
8. **Do not** pick up liquids with the vacuum or use on wet
9. **Do not** use the vacuum on concrete, tar, or similar rough surfaces.
10. **Do not** vacuum frayed carpets or tassels on carpets.
11. **Do not** use the vacuum without the dust cup in place.
12. **Do not** put any object into openings of the vacuum. **Do not** use when any opening is blocked. Keep free of dust, lint, hair and anything that may reduce air flow.
13. Keep hair, loose clothing, fingers, and all parts of body away from openings and moving parts.
14. Store the vacuum indoors. Store after use to prevent accidents.
15. Keep the vacuum cleaner away from stoves and heat-emitting appliance. Heat can deform and discolor the plastic parts of unit. Please use the vacuum in 0 to 40 degrees temperature environment.
16. Always remove the adapter from the power socket when the appliance is not in charging.
17. Unplug charging cord from the appliance and power it off before cleaning or performing maintenance, making tool adjustments, changing accessories or storing to avoid powering it accidentally.
18. The battery must be removed from the appliance before it is scrapped.
19. The battery has to be disposed of safely.
20. The appliance includes Li-ion batteries, **do not** incinerate the batteries or expose to high temperatures, as they may explode.
21. The thermal cutout will switch off the vacuum automatically when it overheats. If this happen, turn off the power switch, wait for 45 minutes to restart the vacuum.
22. Only the adapter provided by the manufacturer can be used.



Please keep the adapter away from liquids.



**Do not** vacuum large piece of paper.



**Do not** vacuum fire or flammable substances.



**Do not** vacuum water or liquids.

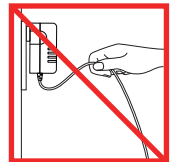

**Do not** remove plug by grasping the cord.

# WHAT'S IN THE BOX

 **CAUTION:** Assemble the vacuum according to chapter "Assembly".

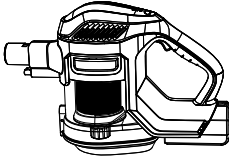

Vacuum main motor

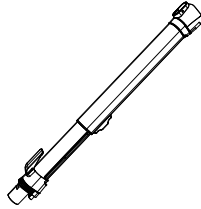

Extension tube

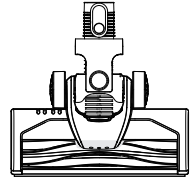

Motorized LED floor brush

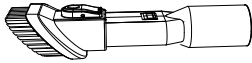

2-in-1 brush

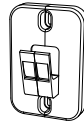

Wall hanger

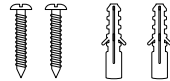

Screws and wall anchors

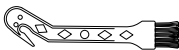

Cleaning brush

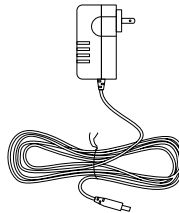

Adapter



HEPA filter



Crevice Nozzle

# OVERVIEW

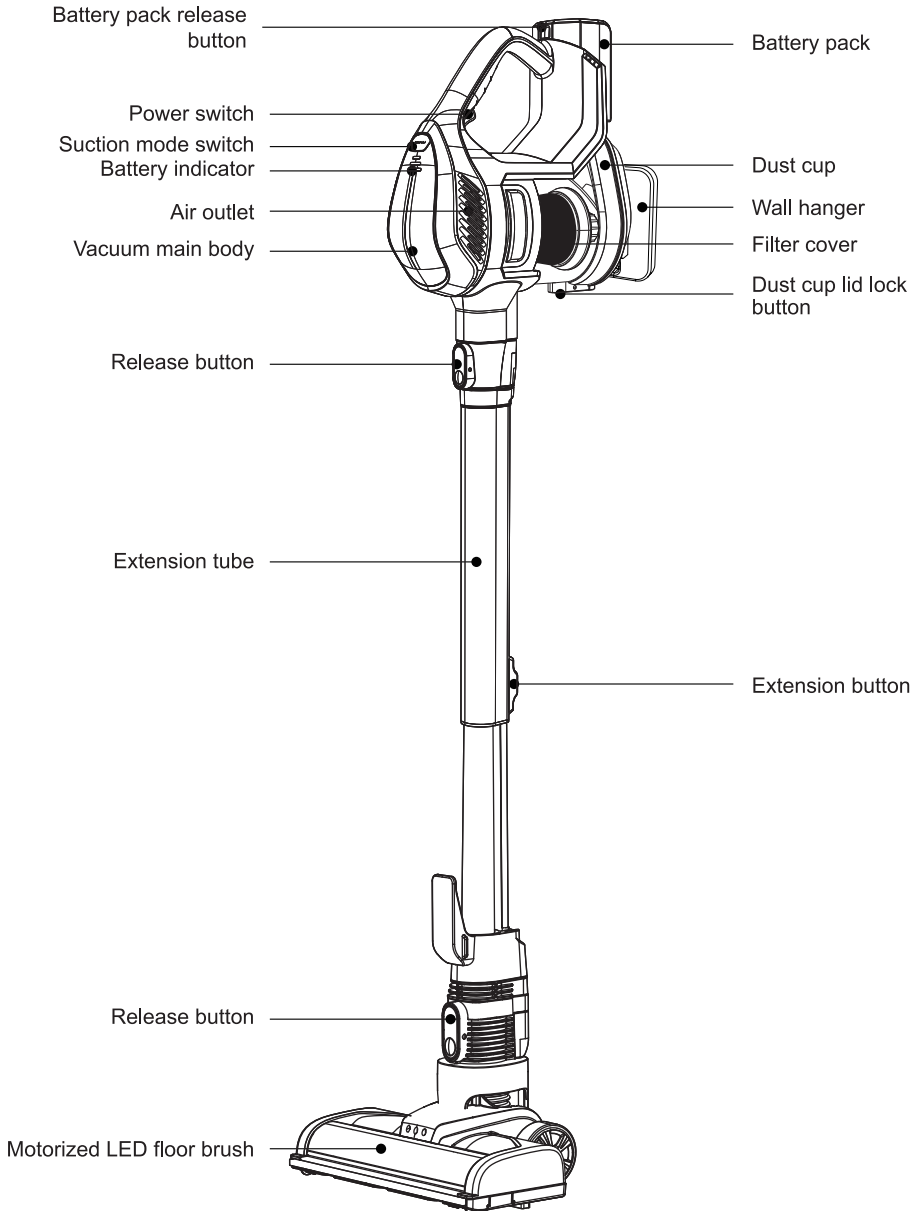

## **ASSEMBLY**

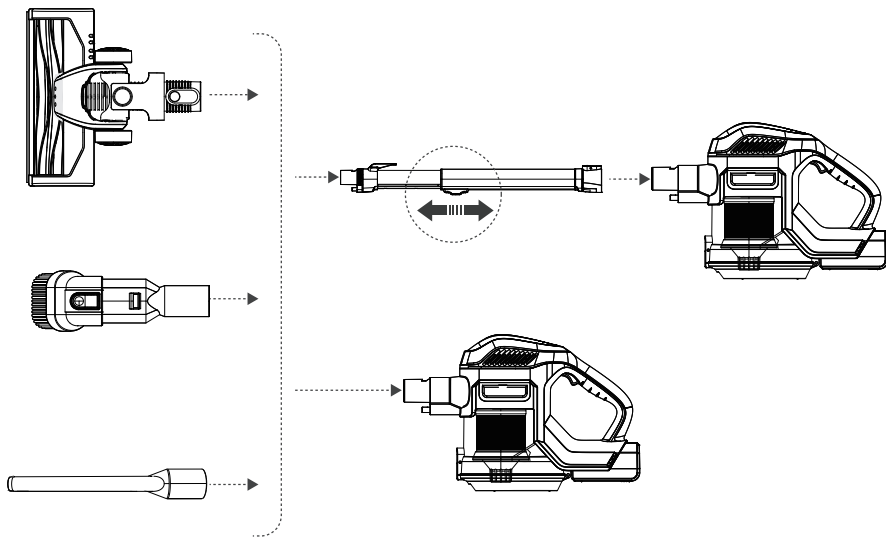

## **SPECIFICATION**

Name	VACUUM CLEANER
Model	T120
Adapter Input Voltage	100-240V~ 50/60 Hz
Adapter Output Voltage	26V

# OPERATING INSTRUCTIONS

## >> Charging Instruction



### CAUTION:

It is important to fully charge your machine before using for the first time and after every use.

The flashing indicator light shows the battery power is low. Please charge the vacuum when the last light flashes.

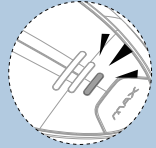

### Charge with the vacuum main body

Plug the adapter into wall outlet and charging head into the vacuum for charging. The battery indicator will be in a cycle of illuminating while the vacuum gets charged. When the vacuum is fully charged, all battery indicators will be solid on. When the vacuum is fully charged, all battery indicators will be solid on.

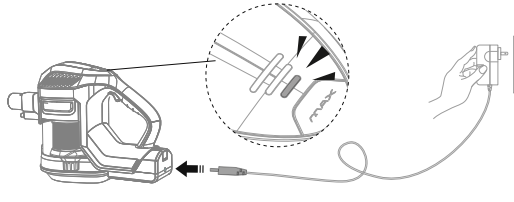

### Charge the battery pack alone

1 Press the release button at the side of the battery pack.

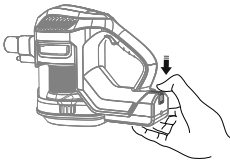

2 Hold the button and pull it out to detach.

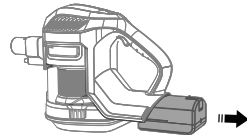

3 Plug the adapter into wall outlet and charging head into the battery pack for charging the it.

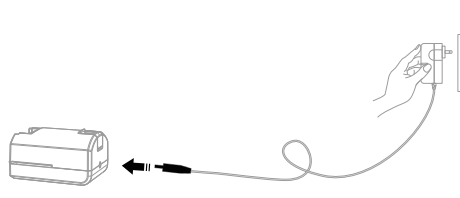



## >> 2-in-1 Brush Instruction

Press the conversion button to pull the bristle back to use as a crevice tool.

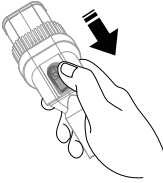

Hold and push out the bristle rectangle to use as a brush.

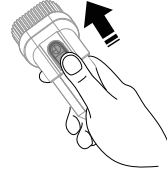

## >> Wall Hanger Instruction

Use the screws and wall anchors to fix the wall hanger at the certain height to mount the vacuum with tube attached. After fixing the wall hanger, store the vacuum on it when not in use.

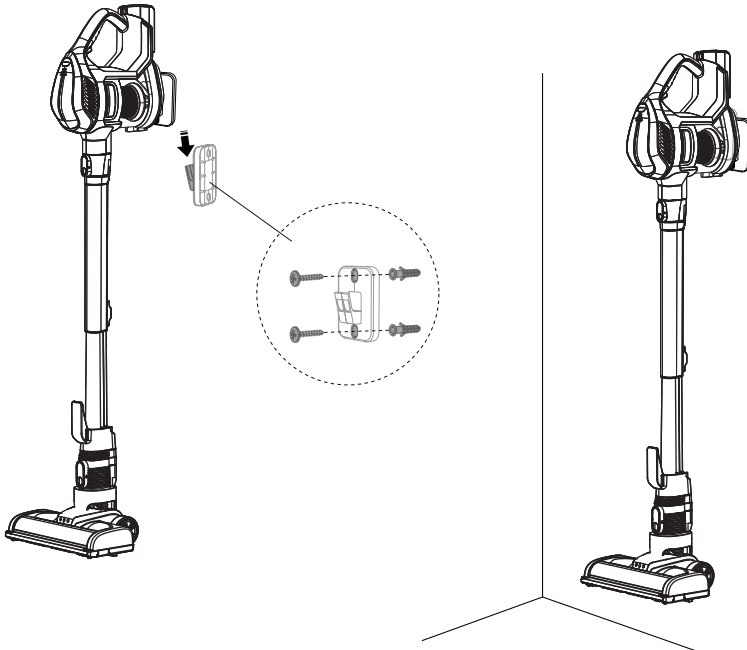

# CLEANING AND MAINTENANCE



## CAUTION:

Always be sure that the vacuum is switched to OFF before attempting to empty the dust cup.

## >> Dust Cup and HEPA Filter Cleaning

1

Empty the dust cup when dust inside is paralleled with the lower rim of filter case. Otherwise, the suction may be weakened.

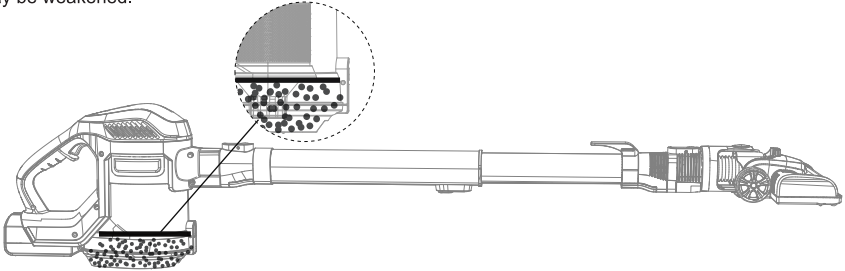

2

Remove the extension tube from the main body before maintaining and cleaning dust cup and HEPA filter.

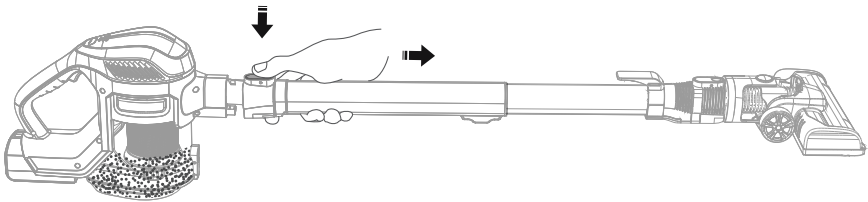

3

Open the dust cup lid to dump dust.

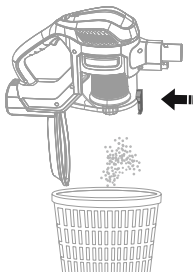

4

Hold and turn the filter case clockwise to detach it.

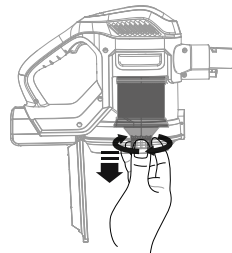

5 Pull up the HEPA filter out of the mesh shell.



6 Brush the HEPA filter with cleaning brush, **do not** rinsing it with water.



7 Only rinse the the mesh shell under tap water.  
(Attention: HEPA Filters is unwashable.)

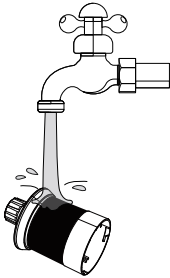

8 Air dry them for at least 24 hours. **Do not** assemble it back until completely dry.

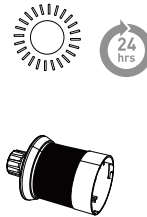

9 Assemble the mesh shell back in place. **Do not** assemble them until completely dry.

 **CAUTION:**

The HEPA filter is not washable, **do not** rinsing it with water, only clean dust on HEPA promptly in dry and replace it every about 3 months. Otherwise, it will result in insufficient filter system and loss of suction.

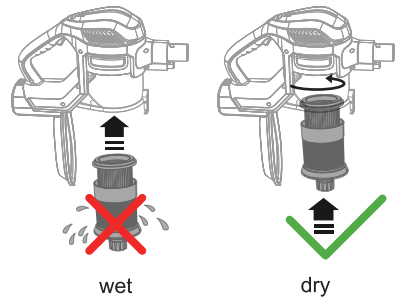

## >> Floor Brush Cleaning

### CAUTION:

When the floor brush stops spinning suddenly or the vacuum cleaner shuts itself off within five seconds, there may be clogs on the roller brush. Please check and clear clogs on the roller brush.

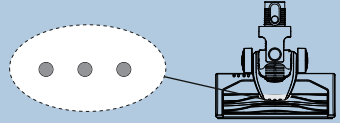

- 1 Push the release switch out at the side of the floor brush to detach the roll

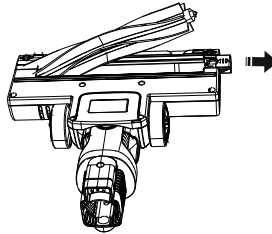

- 2 Use cleaning brush to remove hair and strings entangled on the roller brush.



## CLEAR A CLOG

### CAUTION:

Low suction or vacuum stopped caused by overheat may be due to a clog in the vacuum. Please check and clear clogs in the dust cup, HEPA filter, extension tube and floor brush.

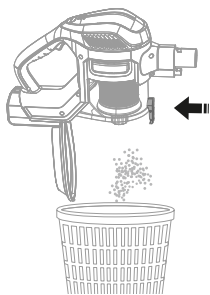

Check and empty the dust cup.

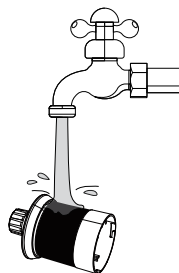

Check and rinse the mesh shell. **Do not** assemble them until completely dry and remember replace with new filter.

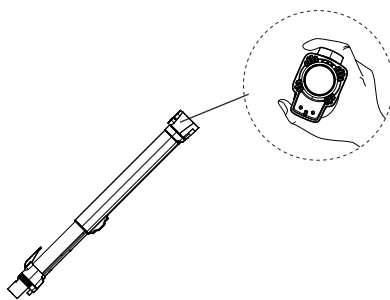

Check if there are any clogs inside the extension tube.

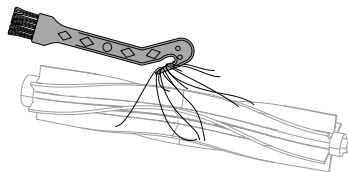

Check the floor brush and clear the clog on the roller brush with the blade.

# TROUBLESHOOTING

PROBLEM	POSSIBLE REASONS	SOLUTIONS
The vacuum can not be charged	The used adapter is not the original one	Please charge the vacuum with the original adapter
	The battery pack/adapter malfunctions	Please contact the customer service for help
The vacuum can not be powered on	The battery runs out	Please charge the vacuum with the original adapter
	The battery pack is not attached correctly	Remove and attach back the battery pack and make sure it is attached in place
	Other malfunctions	Please contact the customer service for help
The vacuum stops working suddenly	The battery runs out	Use the original adapter for charging. It is recommended to charge the vacuum after each time use and use the low suction mode for long runtime
	The floor brush gets stuck	Clean foreign objects entangled on the floor brush
	1. The air duct is blocked 2. The dust cup is full	Clean the floor brush, extension tube, dust cup regularly And replace with new filter
	Other malfunctions	Please contact the customer service for help
The cleaning results are not good	Incorrect use of the vacuum	1. It is recommended to use high suction mode for cleaning complicated environments 2. It is recommended to use the crevice tool for better pickup for vacuuming heavy objects such as beans 3. It is recommended to use the floor brush for cleaning stain
	The battery runs out	Please charge the vacuum fully and try to turn it on again
	1. The air duct is blocked 2. The dust cup is full	Clean the floor brush, extension tube, dust cup and the HEPA filter regularly
	The HEPA filter is blocked	Detach the HEPA filter completely clean and replace it regularly. It is recommended to clean and replace it regularly
There is static during vacuum working	There is too much dust inside the dust cup	Please empty the dust cup
	The vacuum runs at an environment full of static	It's normal that there may be much static in the air in winter and dry regions
The electric floor brush stops working	The floor brush gets stuck	Clean foreign objects entangled on the floor brush
	Other malfunctions	Please contact the customer service for help

# **WARRANTY**

## **>> CUSTOMER CARE**

The 1-year Limited Warranty is applicable to products purchased exclusively from our TMA and authorized outlets, commencing from the original retail purchase date. To activate the extended warranty (12+3 months), we kindly request that you register your product on our website:

<https://tmavacuum.com/pages/register-product>

1. According to the requirements outlined in this instruction manual, the warranty is subject to the following conditions and exclusions.
2. This warranty provides, at no extra cost to you all labor and parts necessary to ensure your machine is in proper operating condition during the warranty period.
3. We provide the repair or replacement of your TMA appliance if your TMA appliance is found to be defective due to faulty materials, workmanship function within 1 year of purchase or delivery. ( If any part is no longer available or out of manufacture, we will replace it with a functional replacement part).

## **>> WHAT IS NOT COVERED**

1. Under your TMA guarantee, TMA shall not be liable for costs of repair or replacement of a product incurred as a result of: Accidental damage, faults caused by negligent use or care, misuse, neglect, careless operation or handling of the TMA appliance which is not in accordance with this TMA Instruction Manual.
2. Machines purchased from an unauthorized dealer.
3. Use of parts and accessories other than those produced or recommended by TMA.
4. Repairs or alterations carried out by unauthorized parties or agents.
5. Use of the machine other than for normal domestic purpose, e.g. for commercial or rental purposes.
6. Reduction in battery run time due to battery age or use.

## **>> WARRANTY SERVICE**

1. If you have a query about your TMA appliance, please contact the TMA customer service email:  
**support@tmavacuum.com**
2. Please inform us your model name/number, purchase date, order number, machine problem and your requirement.
3. Your model number can be found on rating plate.
4. Please keep your purchase receipt in a safe place to ensure you have this information.

Under the warranty, we are committed to providing exceptional customer service to address any defects in quality or materials under normal, non-commercial usage conditions.



TMA



————— Different for you —————

No.1130