

# PINNA<sup>®</sup>COLO<sup>™</sup>

PIZZA OVENS

# IBRIDO

HYBRID GAS-WOOD  
PIZZA OVEN



## **IMPORTANT:**

THIS INSTRUCTION MANUAL CONTAINS IMPORTANT INFORMATION NECESSARY FOR THE PROPER ASSEMBLY AND SAFE USE OF THE APPLIANCE.

READ AND FOLLOW ALL WARNINGS AND INSTRUCTIONS BEFORE ASSEMBLING AND USING THE APPLIANCE.

FOLLOW ALL WARNINGS AND INSTRUCTIONS WHEN USING THE APPLIANCE.

KEEP THIS MANUAL FOR FUTURE REFERENCE.

## **OWNER'S MANUAL, USER GUIDE AND WARRANTY**

**MODEL NO: PPO-1-03**

GAS BARBECUE GRILL  
 GRIL BARBECUE AU GAZ  
 ANS Z21.89-2017 • CSA 1.18-2017  
 OUTDOOR COOKING GAS APPLIANCE  
 APPAREIL DE CUISSON AU GAZ POUR  
 L'EXTÉRIEUR  
 FOR Propane  
 POUR GAZ PROPANE LIQUIDE

MODEL : PPO-1-03  
 INPUT RATING: 35,000 BTU/H  
 DÉBIT CALORIFIQUE : 35,000 BTU/H SERIAL  
 NUMBER : PPO-1-03\*1\*\*\*  
 NUMÉRO DE SÉRIE : PPO-1-03\*1\*\*\*  
 For Outdoor Use Only. If Stored Indoors, Detach and  
 Leave Cylinder Outdoors  
 Uniquement pour utilisation extérieure. Si l'appareil  
 est rangé à l'intérieur, la bouteille doit être  
 débranchée et laissée à l'extérieur.

Gas Type:Propane

- \* Do not store a spare Propane cylinder under or near this appliance.
- \* Ne rangez pas une bouteille de gaz propane de recharge près ou sous cet appareil.
- \* Never fill the cylinder beyond 80 Percent full.
- \* Ne remplissez jamais la bouteille au-delà de 80 % de sa capacité.
- \* If the information beyond is not followed exactly, a fire causing death or serious injury may occur.
- \* Le non-suivi de ces informations à la lettre peut provoquer un incendie pouvant conduire à de sérieuses blessures corporelles, voire la mort.
- \* Do not use this appliance under overhead combustible surfaces.
- \* Ne pas utiliser cet appareil dans un endroit confiné ou sous un abris inflammable.
- \* CAUTION: Use only the gas pressure regulator supplied with this appliance. This regulator is set for an outlet pressure of 11 iwc.
- \* ATTENTION : N'utiliser que le régulateur de pression de gaz fourni avec l'appareil. Ce régulateur est réglé pour une pression de sortie de 11 iwc.

\* Turn off Propane supply at cylinder when appliance is not in use.

\* Coupez l'arrivée de gaz quand le produit n'est pas utilisé.

Minimum clearance from side and back of unit to combustible construction , 24 inch from sides and 24 inch from back

Dégagement minimal des côtés et de l'arrière de l'unité à la construction combustible, 24 pouces des côtés et, 24 pouces de l'arrière.

This appliance is not intended for commercial use.

Cet appareil n'est pas destiné à un usage commercial.

**LIGHTING INSTRUCTION**

1. Read all instructions before lighting.

**TO LIGHT THE BURNER**

1. Open the gas tank valve first, and then remove the oven door panel;
2. Press the knob clockwise and rotate it to 90° for 5-10 seconds, and observe whether the ignition needle discharges. When the product is in a cooling state, the first ignition success rate is low. If the first ignition is unsuccessful, you should turn the knob immediately Recover counterclockwise, and try to ignite again every 3-5 minutes.
3. If the ignition needle does not discharge, please use a igniter or other kind of fire. Place the kind of fire close to the burner, and then turn the knob clockwise to 90°. The burner can be ignited by ventilation. When using other kind of fire to ignite, let the fire kind of Keep a safe distance of 200mm from the arm.

**INSTRUCTION D'ÉCLAIRAGE**

1. Lisez toutes les instructions avant d'allumer.

**POUR ALLUMER LE BRULEUR**

1. Ouvrez d'abord le robinet du réservoir de gaz, puis retirez le panneau de la porte de la fournaise;
2. Appuyez sur le bouton dans le sens des aiguilles d'une montre et tournez-le à 90 ° pendant 5 à 10 secondes, et observez si l'aiguille d'allumage se décharge. Lorsque le produit est dans un état de refroidissement, le taux de réussite du premier allumage est faible. Si le premier allumage échoue, tournez immédiatement le bouton de récupération dans le sens antihoraire et essayez de vous rallumer toutes les 3 à 5 minutes.
3. Si l'aiguille d'allumage ne se décharge pas, veuillez utiliser un allumeur ou un autre type de feu. Placez le type de feu à proximité du brûleur, puis tournez le bouton dans le sens des aiguilles d'une montre à 90 °. Le brûleur peut être allumé par ventilation. Lorsque vous utilisez un autre type de feu pour allumer, laissez le type de feu Garder une distance de sécurité de 200 mm du bras.



**PINNA COLO**  
 PIZZA OVENS

	PROPANE	RATE BTU INPUT	
Components	Orifice Size		
Main burner	1.78 MM	35,000 BTU/Hr	

# TABLE OF CONTENTS

CSA Information.....	2
Table of Contents.....	3
Pinnacola Pizza Oven Information.....	4
Outdoor Oven Safety.....	5
Precautions .....	6
Product Dimensions.....	7
Parts Explosive View .....	8
Hybrid Gas-Wood Oven Part List .....	9
Installation.....	10
Leak Testing.....	23
Gas Use Caution.....	24
Tips for Gas Use .....	25
Gas Cooking.....	28
Wood Use Caution .....	29
Tips for Wood Use.....	29
Wood Cooking.....	30
Troubleshooting Maintenance .....	31
Heating and Cleaning the Oven .....	32
Safety Instructions.....	33
Limited Warranty .....	34

# PINNACOLO™

PIZZA OVENS

## **CONGRATULATIONS!**

ON BECOMING A NEW MEMBER OF THE PINNACOLO FAMILY!



# WARNING

**READ AND UNDERSTAND  
INSTRUCTIONS PRIOR TO ASSEMBLY**

Thank you for your purchase! We know that you have many brands and products to choose from and we are honored to know that you have decided to take one of our products into your home and hope that you enjoy it.

Pinnacolo Pizza Ovens are designed according to the strictest safety and performance standards for the North American market. We are available to answer any questions you may have regarding how to install, use and care for your products.

We hope that this manual will help you learn to use the product in the safest and most effective manner.

If you have any questions or concerns, please contact the dealer from whom you purchased it or contact us through our website at [www.FireOneUp.com](http://www.FireOneUp.com).

Please read the important safety instructions before using the appliance for your own safety, and to reduce the risk of hazards such as injury, fire and electrical shock.

Please keep this manual for future use.

Once again, thank you!

The Team at PINNACOLO PIZZA OVENS

[www.FireOneUp.com](http://www.FireOneUp.com)

# OUTDOOR OVEN SAFETY

## Your safety and the safety of others are very important.

We have provided many important safety messages in this manual and on your appliance. Always read and obey all safety messages.



This is the safety alert symbol.

This symbol alerts you to potential hazards that can kill or hurt you and others.

All safety messages will follow the safety alert symbol and either the word "DANGER" or "WARNING."

These words mean:



Failure to comply with these instructions could result in a fire or explosion that could cause serious bodily injury, death, or property damage.



You can be killed or seriously injured if you don't follow instructions.

All safety messages will tell you what the potential hazard is, tell you how to reduce the chance of injury, and tell you what will happen if the instructions are not followed.

## DANGER

### IF YOU SMELL GAS:

1. Shut off gas to the appliance.
2. Extinguish any open flame.
3. Open lid.
4. If odor continues, move away from the appliance and immediately call your gas supplier or your fire department.

Failure to follow these instructions could result in fire or explosion which could cause property damage, personal injury or death.

## WARNING

1. Do not store or use gasoline or other flammable liquids or vapors in the vicinity of this or any other appliance.
2. Gas not connected for use shall not be stored in the vicinity of this or any other appliance.

## WARNING

1. Never operate this appliance unattended.
2. Never operate this appliance within 10ft (3.0m) of any structure, combustible material or other gas tank.
3. Never operate this appliance within 7.62 m/25 ft of any flammable liquid.
4. Do not fill any cooking vessel beyond maximum fill line.
5. Never allow oil or grease to get hotter than 400°F or 200°C. If the temperature exceeds 400°F (200°C) or if oil begins to smoke, immediately turn the burner or gas supply OFF.
6. Heated liquids remain at scalding temperatures long after the cooking process. Never touch cooking appliance until liquids have cooled to 115°F (45°C) or less.
7. If a fire should occur, keep away from the appliance and immediately call your fire department. Do not attempt to extinguish an oil or grease fire with water.

## WARNING

1. Use outdoors only.
2. Read the instructions before using the appliance.
3. Warning: accessible parts may be very hot. Keep young children away.
4. This appliance must be kept away from flammable materials during use.
5. Do not move the appliance during use.
6. Turn off the gas supply at the source after use.
7. Do not modify the appliance.

The gas regulator should comply with CAN/CSA-B339 and local code.

The flexible hose should comply with relevant CAN/CSA-B339 standard and local code.

The maximum hose length should be 1.5m.

# PRECAUTIONS

## 1. for all appliances

- (1) A statement that the installation must conform with local codes or, in the absence of local codes, with the National Fuel Gas Code, ANSI Z223. 1/NFPA 54, Storage and Handling of Liquefied Petroleum Gases, ANSI/NFPA 58; or Natural Gas and Propane Installation Code, CSA B149. 1: Propane Storage and Handling, CSA B149. 2; or the Standard for Recreational Vehicle ANSI A119. 2/NFPA 1192; and Recreational Vehicle Code, CSA Z240 RV Series, as applicable
- (2) Instructions to the effect that this appliance shall be used only outdoors, and shall not be used in a building, garage, or any other enclosed area.
- (3) This appliance is not intended to be installed in or on a boat. This appliance is not intended to be installed in or on a recreational vehicle.
- (4) Minimum clearance from sides and back of unit to combustible construction, 24 inches (61cm) from both sides and 24 inches (61cm) from the back.
- (5) The regulator and hose assembly must be inspected before each use of the oven. The hose used should not exceed 1.5m. If there is excessive abrasion or wear or if the hose is cut, it must be replaced prior to the oven being put into operation. The replacement hose assembly shall be that specified by the manufacturer.
- (6) statement: the appliance is not intended for commercial use,
- (7) When cooking with oil or grease, have a type BC or ABC fire extinguisher readily available.
- (8) In the event of an oil or grease fire do not attempt to extinguish with water. Immediately call the fire department. A Type BC or ABC fire extinguisher may, in some circumstances contain the fire.
- (9) In the event of rain, snow, hail, sleet, or other forms of precipitation while cooking with oil or grease, cover the cooking vessel immediately and turn off the appliance burners and gas supply. Do not attempt to move the appliance or cooking vessel.
- (10) When cooking, the appliance fryer or boiler must be on a level, stable noncombustible surface in an area clear of combustible material. An asphalt surface (blacktop) may not be acceptable for this purpose.
- (11) Do not leave the appliance unattended. Keep children and pets away from the appliance at all times.
- (12) This appliance will be hot during and after use. Use insulated oven mitts or gloves for protection from hot surfaces or splatter from cooking liquids.
- (13) When cooking with oil or grease, the thermometer provided MUST be used. Follow instructions in this manual for proper installation and use of the thermometer. If the thermometer supplied with this fryer or boiler has been lost or damaged, a replacement thermometer must be one specified by the appliance manufacturer.
- (14) Do not place empty cooking vessel on the appliance while in operation. Use caution when placing anything in cooking vessel while the appliance is in operation.
- (15) Do not move the appliance when in use. Allow the cooking vessel to cool to 115°F (45°C) before moving or storing.
- (16) This appliance is not intended for and should never be used as a heater.
- (17) If the temperature exceeds 400°F (200°C) or if oil begins to smoke, immediately turn the burner or gas supply OFF and wait for the temperature to decrease to less than 350°F (175°C) before relighting burner according to the manufacturers instructions. If there is a lid (cover), do not remove the lid.
- (18) Maintenance instructions (including recommended frequency guidelines) relative to:
  - a. Keeping appliance area clear and free from combustible materials, gasoline, and other flammable vapors and liquids:
  - b. Not obstructing the flow of combustion and ventilation air,
  - c. Keeping the ventilation opening(s) of the tank enclosure free and clear from debris
  - d. Visually inspect the burners
  - e. Cleaning appliance, including special surfaces, with recommended cleaning agents, if necessary
  - f. Checking and cleaning burner for insects and insect nests. A clogged tube can lead to a fire beneath the appliance.

# PRODUCT DIMENSIONS

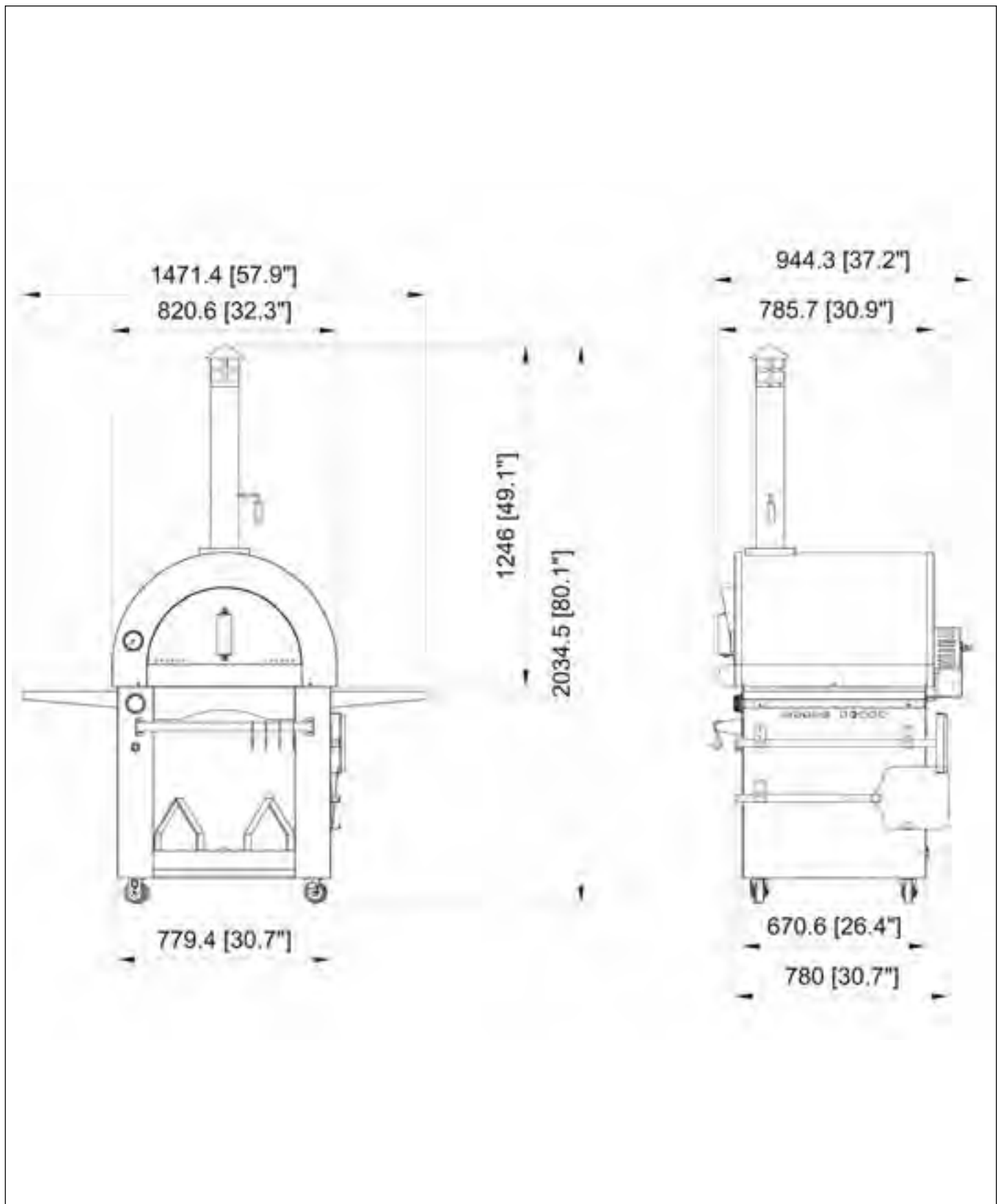

# PARTS EXPLOSIVE VIEW

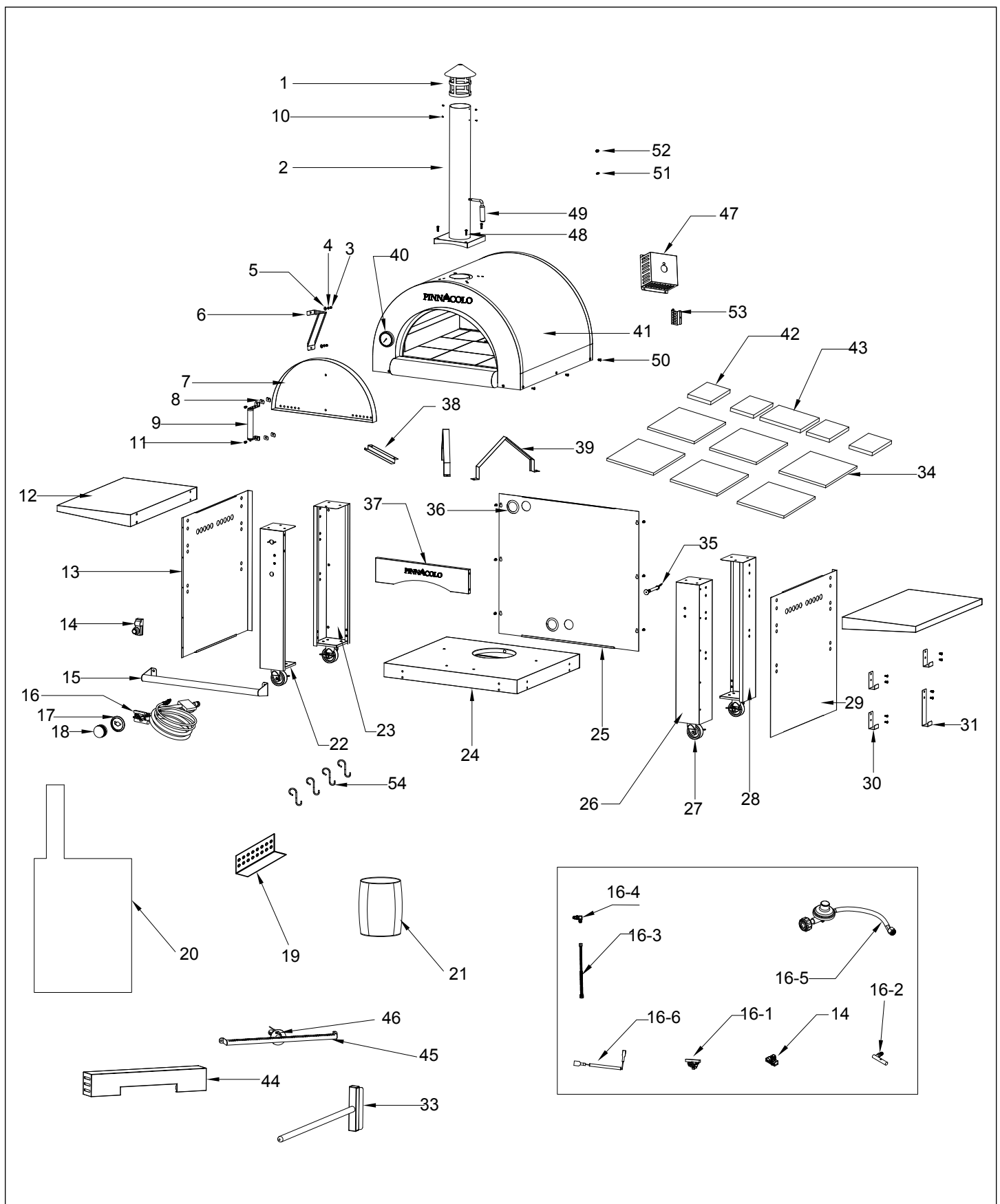



# HYBRID GAS-WOOD OVEN PART LIST

NO.	PART NAME	QTY
1	Chimney Top Component	1
2	Chimney Component	1
3	1/4" Hex Nut	2
4	1/4" Spring Washer	2
5	1/4" Flat Gasket	2
6	Anti-Toppling Support Plate for Door	1
7	Oven Door	1
8	Mica Plate 2	4
9	Oven Door Handle	1
10	5/32" 10mm Large Flat Head Screw	7
11	1/4" 14mm Cross Screw	54
12	Side Shelf	2
13	Left Side Panel	1
14	Igniter	1
15	Front Handle	1
16	Gas System Assembly	1
17	Oven Knob Trim	1
18	Oven Knob	1
19	Log Holder	1
20	Pizza Oven Cover	1
21	Cylinder Cover	4
22	Left Front Support Leg Assembly	1
23	Left Rear Support Leg Assembly	1
24	Strengthen Bottom Panel	1
25	Rear Panel	1
26	Right Front Support Leg Assembly	1
27	Swivel Brake Caster	4
28	Right Rear Support Leg Assembly	1
29	Right Panel	1
30	Hook 1	3

NO.	PART NAME	QTY
31	Hook 2	1
33	Pizza Oven Broom	1
34	Cordierite Firebrick - Front	6
35	Cylinder Fixed Rod	1
36	Rubber Ring	2
37	Front Decorating Panel	1
38	Corrugated Pipe Hook	1
39	Support for Strengthen Bottom Panel	2
40	Thermometer	1
41	Oven Dome	1
42	Cordierite Firebrick - Rear Sides	4
43	Cordierite Firebrick - Rear Center	1
44	Dust Free Cover of Burner	1
45	T-Shape Burner	1
46	Ignition Needle	1
47	Protection Cover of Gas System	1
48	1/4" 35mm Large Flat Head Screw	4
49	Air Door Handle	1
50	1/4" 12mm Large Flat Head Screw	28
51	5/32" Flat Gasket	10
52	5/32" Screw	10
53	Fixed Hood for Ignition Needle	1
54	S-Hook	1

## Gas System Assembly

16.1	Gas Valve	1
16.2	Gas Pipe	1
16.3	Corrugated Pipe	1
16.4	Nozzle	1
16.5	Regulator and Gas Hose Assembly	1
16.6	Ignition Wire	1

# INSTALLATION

## STEP 1

1. Lay the Left Side Panel (Part No. 13), and install the Left Front Support Leg Assembly (Part No. 22) and the Left Rear Support Leg Assembly (Part No. 23) as shown in the figure. When installing the 1/4" 12mm Large Flat Head Screw (Part No. 50), 3-5mm tolerance needs to be reserved. no need to lock tightly.
2. Install the Right Panel (Part No. 29), Right Front Support Leg Assembly (Part No. 26), and Right Rear Support Leg Assembly (Part No. 28), as in Step 1.

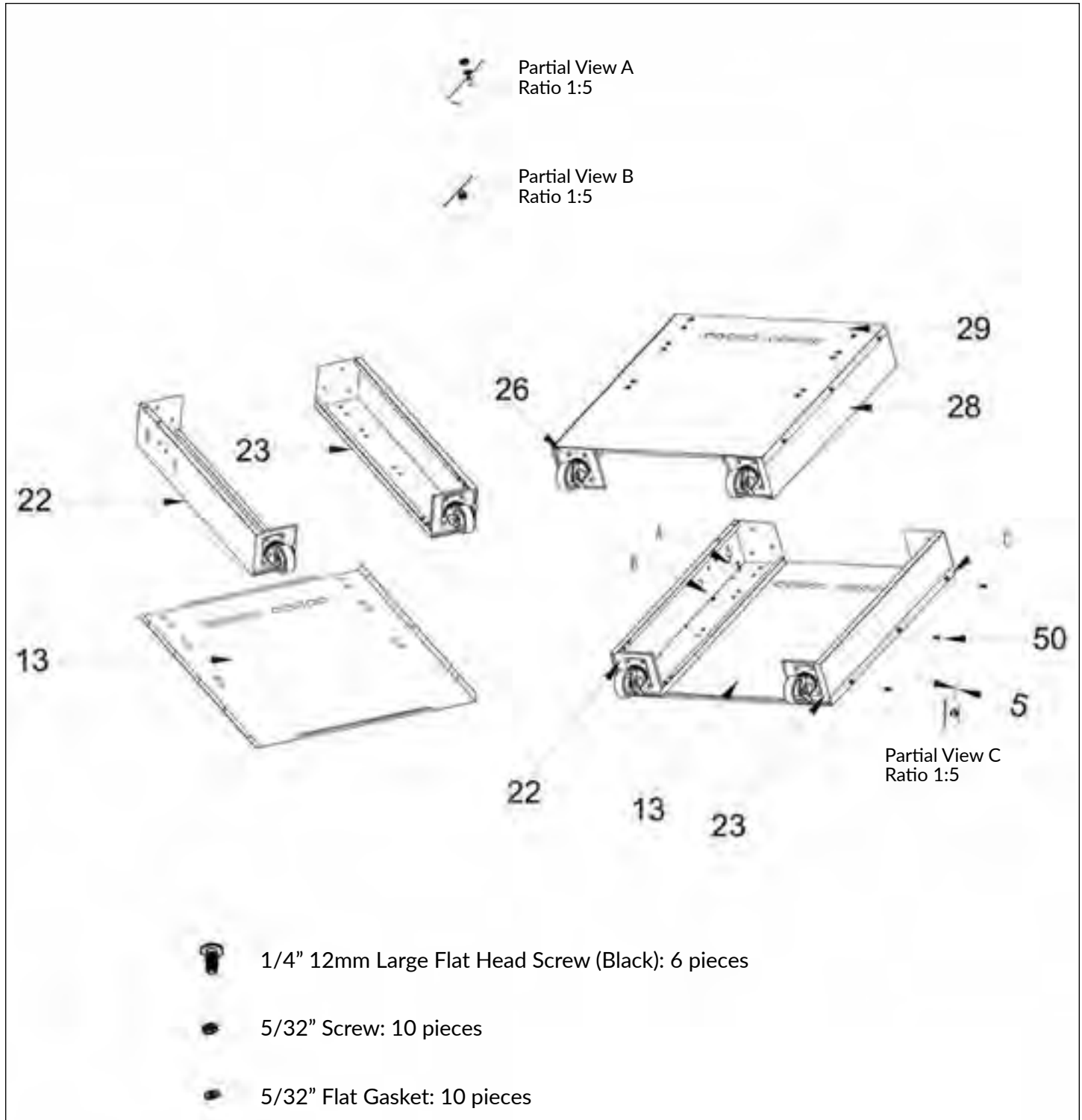

# INSTALLATION

## STEP 2

1. Lay the assembled Left Side Panel (Part No. 13), Left Front Support Leg Assembly (Part No. 22) and the Left Rear Support Leg Assembly (Part No. 23) as shown in the figure. Install the Strengthen Bottom Panel (Part No. 24) as shown in figure.
2. Install the Right Panel (Part No. 29), Right Front Support Leg Assembly (Part No. 26), and Right Rear Support Leg Assembly (Part No. 28), in the same way as in Step 1.

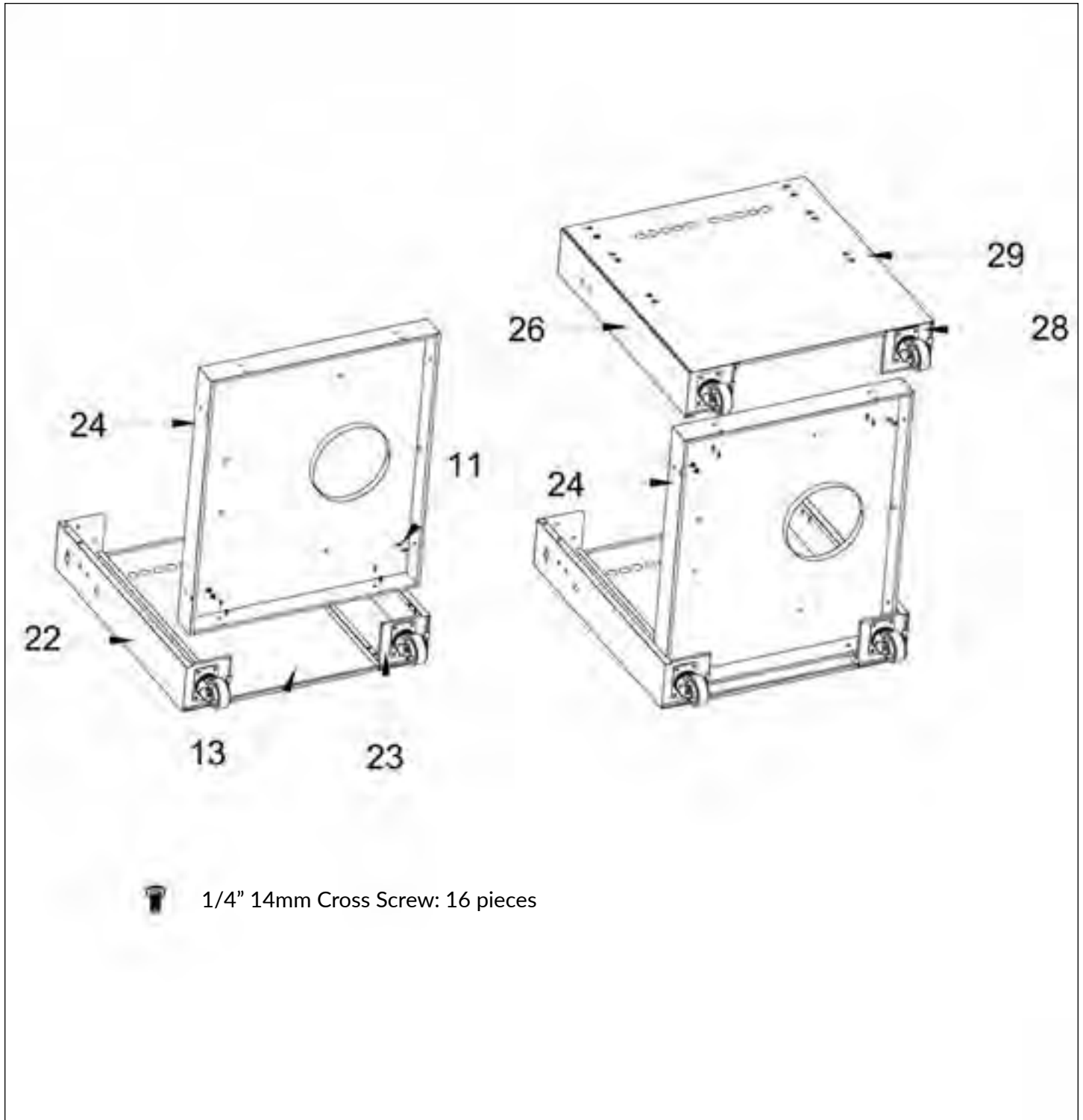

# INSTALLATION

## STEP 3

1. Align the holes of the Rubber Ring (Part No. 36) and buckle them on the the Right Panel (Part No. 29) and Left Side Panel (Part No. 13). Use 6 pieces of 1/4" 12mm Large Flat Head Screw (Part No. 50) to connect.
2. Install the Cylinder Fixed Rod (Part No. 35) as shown in the figure.

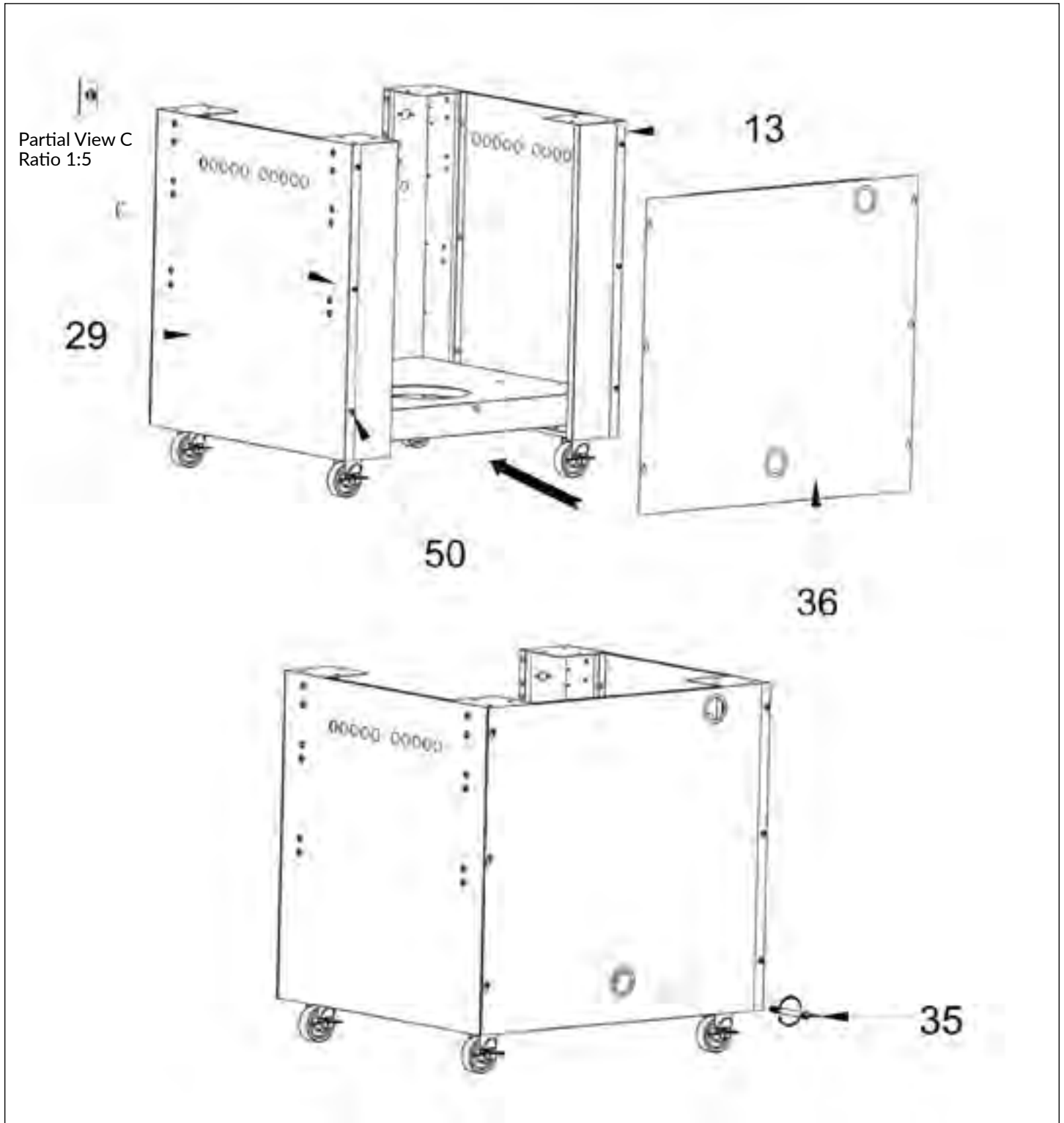

# INSTALLATION

## STEP 4

1. Install 5/32" 10mm Large Flat Head Screw (Part No. 10) and Cylinder Fixed Rod (Part No. 35).
2. Install 2 pieces of the Support for Strengthen Bottom Panel (Part No. 39) as shown.

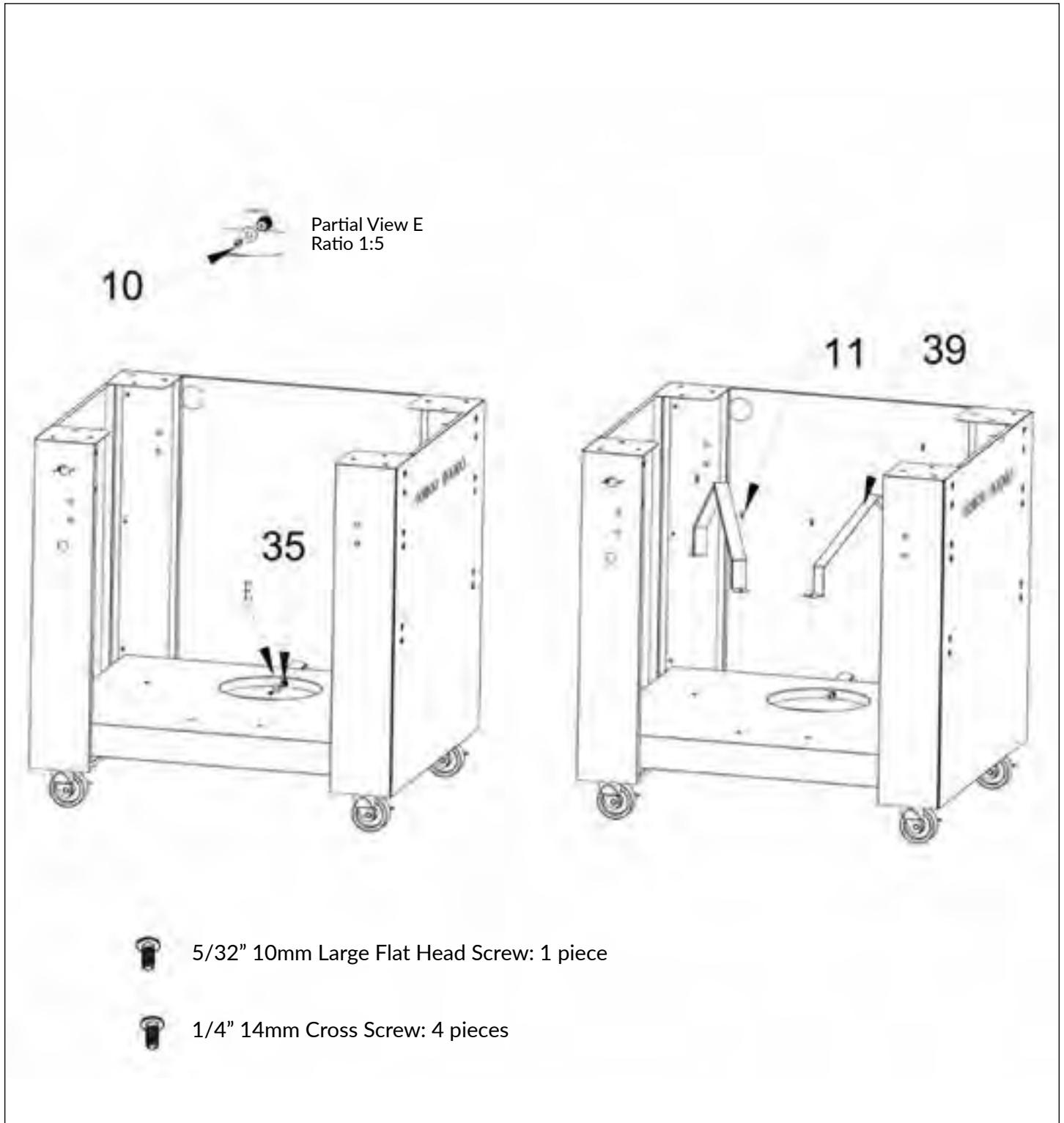

# INSTALLATION

## STEP 5

1. Install the Gas System Assembly (Part No. 16) and the Oven Knob Trim (Part No. 17) as shown in the figure. Install the Oven Knob (Part No. 18) as shown in the figure.
2. Use 4 pieces of 1/4" 14mm Cross Screw (Part No. 11) to install the Left Front Support Leg Assembly (Part No. 22), Right Front Support Leg Assembly (Part No. 26) to the Front Decorating Panel (Part No. 37).



# INSTALLATION

## STEP 6

1. Straighten the combination of the Corrugated Pipe (Part No. 16-3) and Nozzle (Part No. 16-4), pass through the Rubber Ring (Part No. 36), and place as shown in figure.
2. Install Oven Dome (Part No. 41) with the cart body as shown in figure.

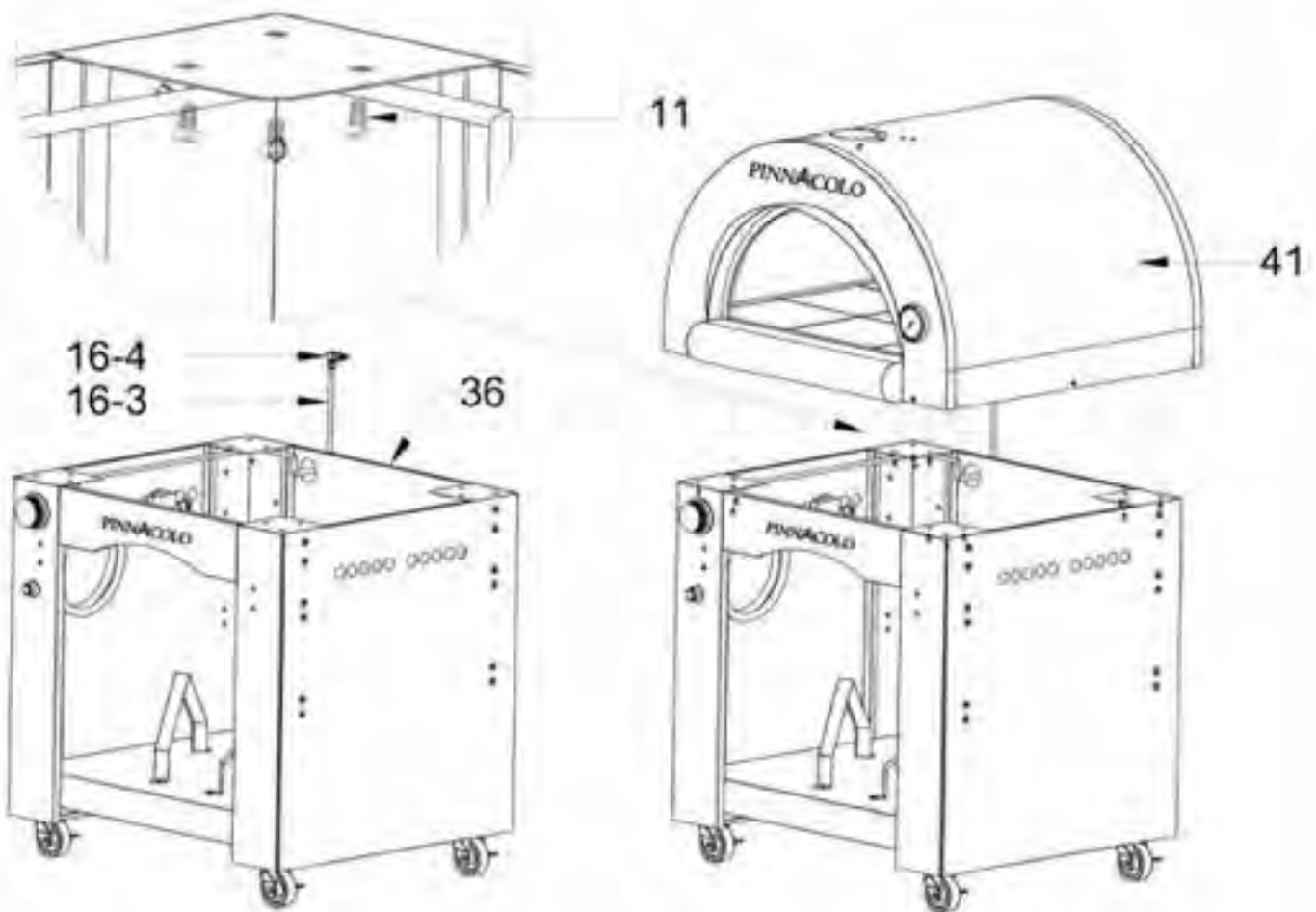

 1/4" 14mm Cross Screw: 12 pieces

# INSTALLATION

## STEP 7

1. Install the Corrugated Pipe Hook (Part No. 38) as shown in the figure.
2. Place the Corrugated Pipe (Part No. 16-3) and the Ignition Needle (Part No. 46) on the Corrugated Pipe Hook (Part No. 38) as shown in the figure, and bind them together with a cable tie.

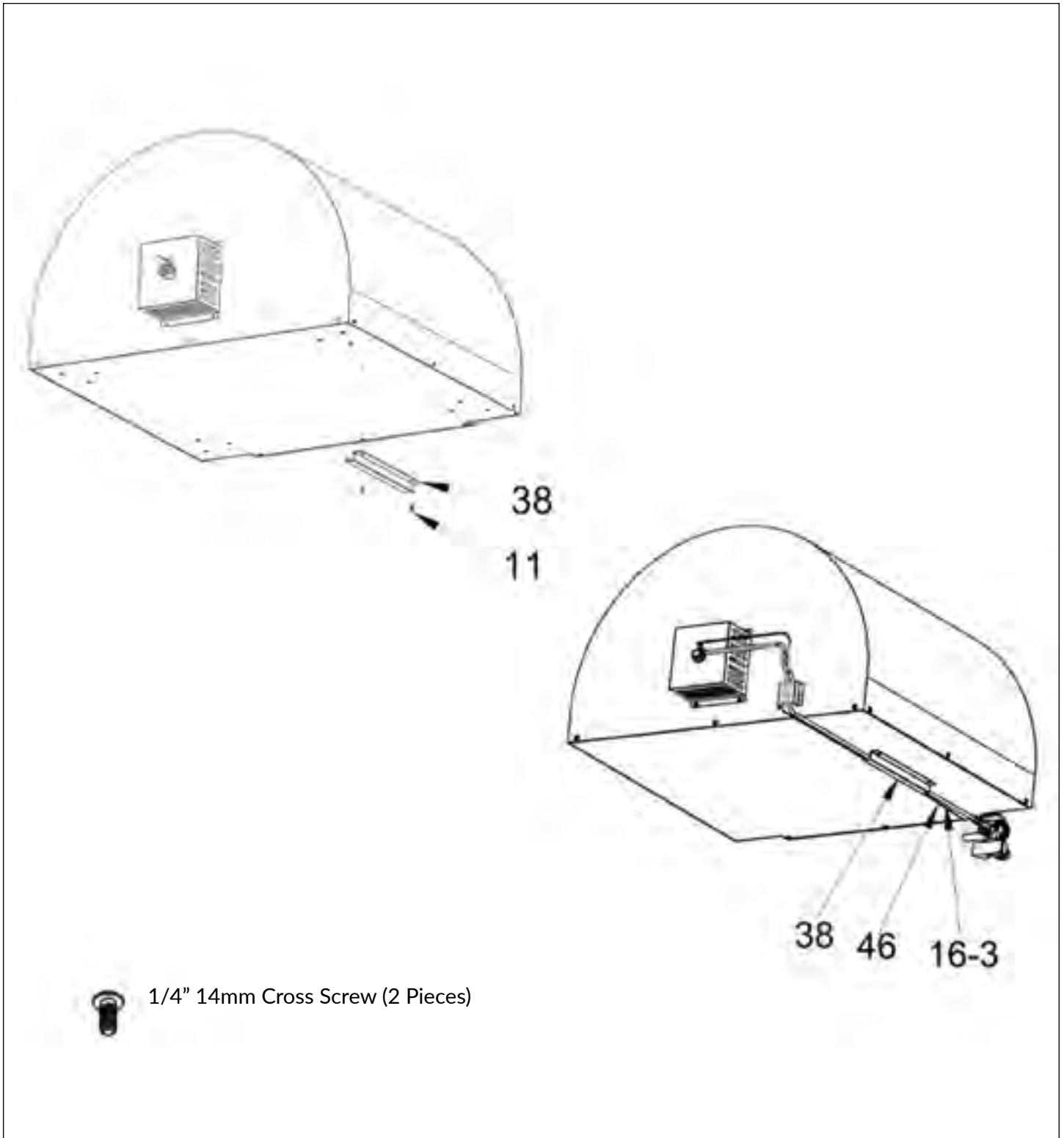



# INSTALLATION

## STEP 8

1. Install the Fixed Hood for Ignition Needle (Part No. 53) as shown in the figure.
2. Install the Nozzle (Part No. 16-4) as shown in the figure.



# INSTALLATION

## STEP 9

1. Install the Chimney Top Component (Part No. 1) to the Chimney Component (Part No. 2) as shown in the figure.
2. Install the Chimney Component (Part No. 2) to the Oven Dome (Part No. 41) using 4 pieces of 1/4" 14mm Cross Screw (Part No. 11) as shown in the figure.
3. Install the Chimney Component (Part No. 2) to the Oven Dome (Part No. 41) using 4 pieces of 1/4" 35mm Large Flat Head Screw (Part No. 48).

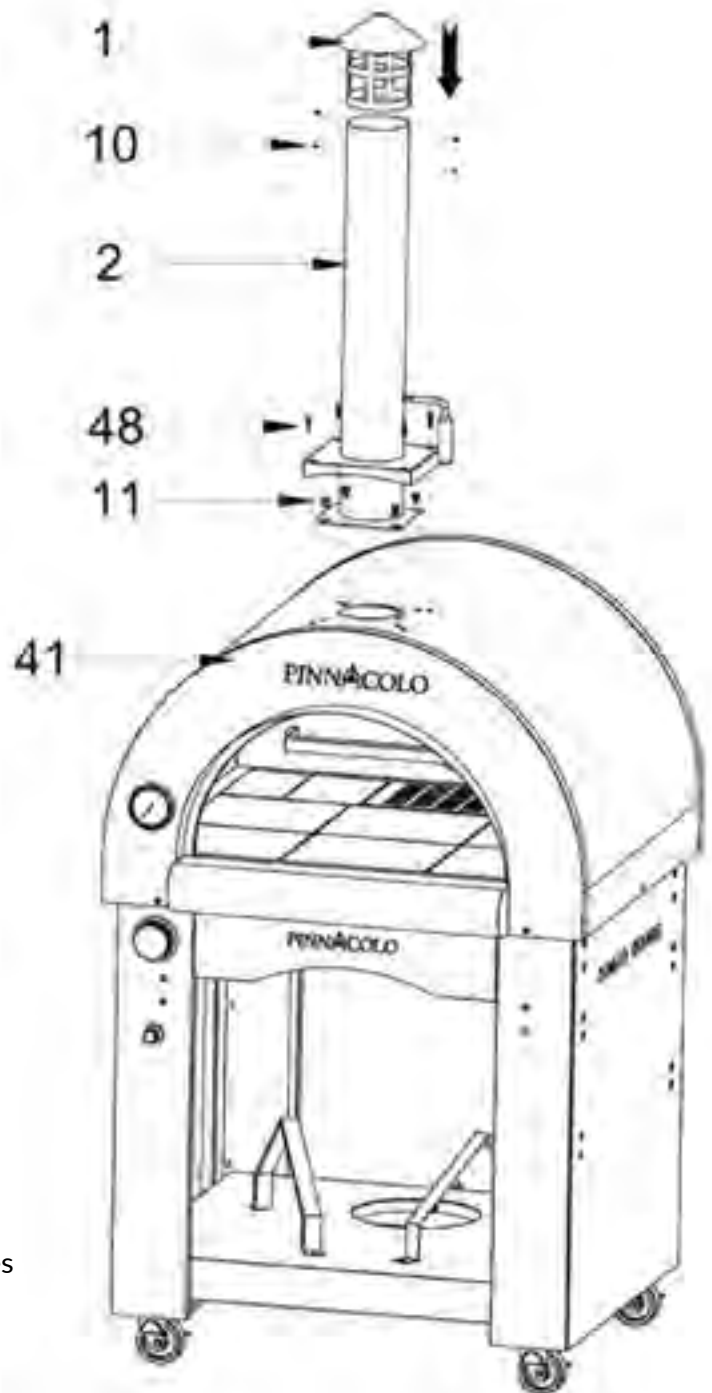

- 1/4" 14mm Cross Screw: 4 pieces
- 1/4" 35mm Large Flat Head Screw: 4 pieces
- 5/32" 10mm Large Flat Head Screw: 4 pieces

# INSTALLATION

## STEP 10

1. Install 2 pieces of the Side Shelf (Part No. 12) to the Left Side Panel (Part No. 13) and Right Panel (Part No. 29) using 8 pieces of 1/4" 12mm Large Flat Head Screw (Part No. 50) as shown in the figure.
2. Install the Front Handle (Part No. 15) to Left Front Support Leg Assembly (Part No. 22), and Right Front Support Leg Assembly (Part No. 26) using 4 pieces of 1/4" 14mm Cross Screw (Part No. 11) as shown in the figure.

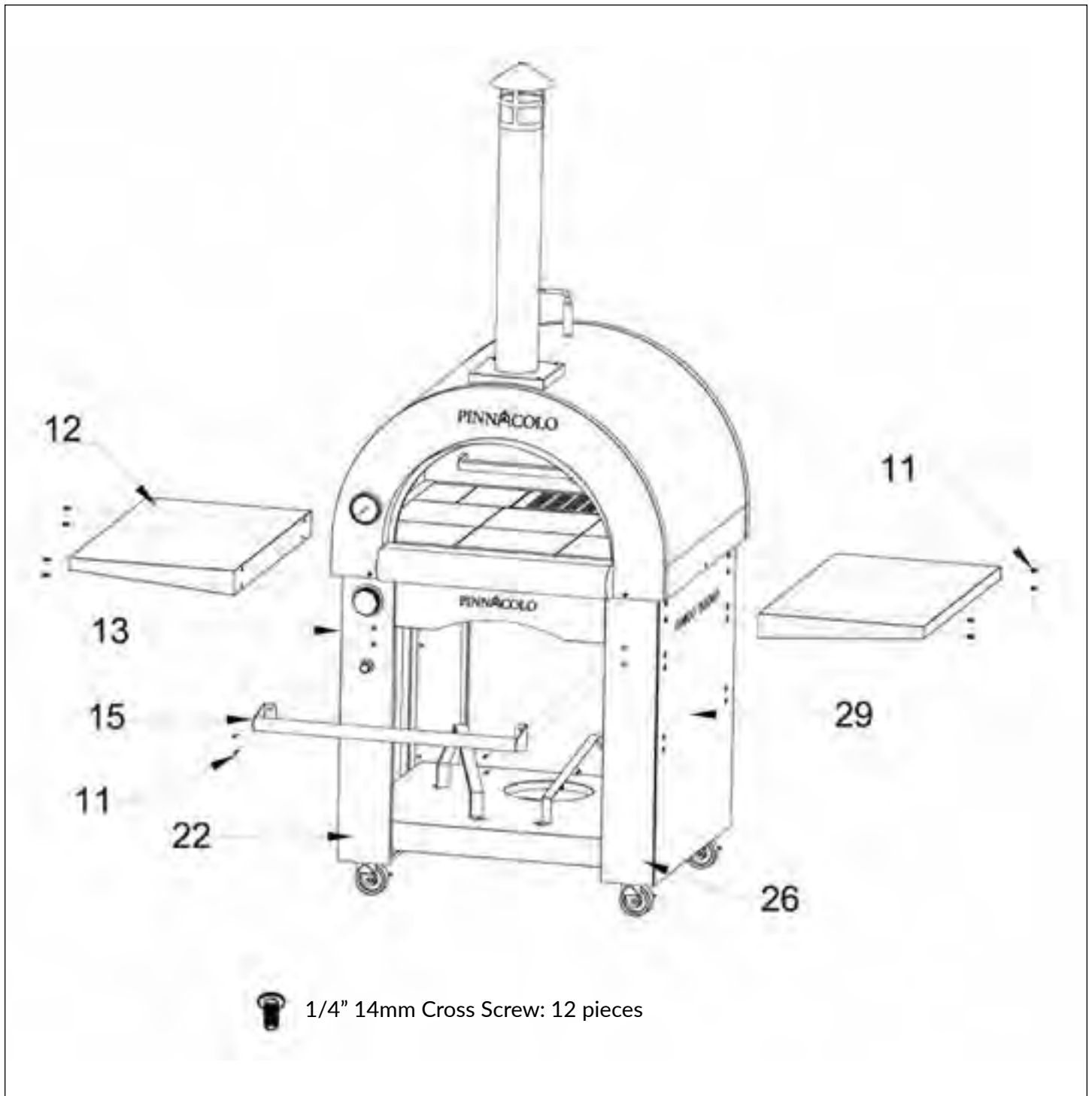

# INSTALLATION

## STEP 11

1. Install 3 pieces of Hook 1 (Part No. 30) and 1 piece of Hook 2 (Part No. 31) using 8 pieces of 1/4" 12mm Large Flat Head Screw (Part No. 50) to Right Panel (Part No. 29) as shown in the figure. Then place Pizza Oven Broom (Part No. 33) on Hook 1 (Part No. 30) and Hook 2 (Part No. 31).
2. Place the S-Hook (Part No. 54) into Front Handle (Part No. 15) as shown in the figure.

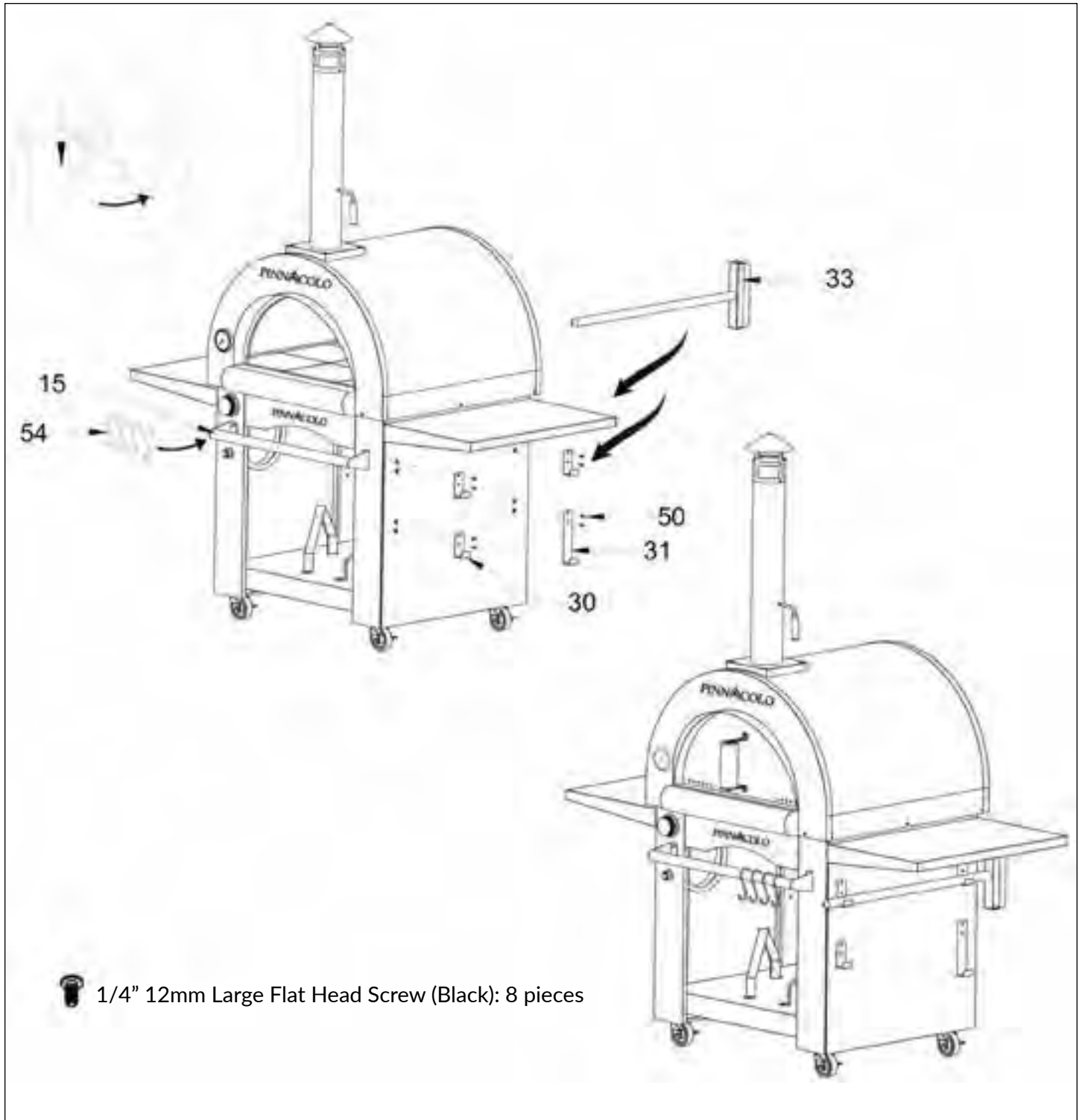

# INSTALLATION

## STEP 12

Use below screws to complete the assembly of pizza oven door (Part No. 7) assembly.

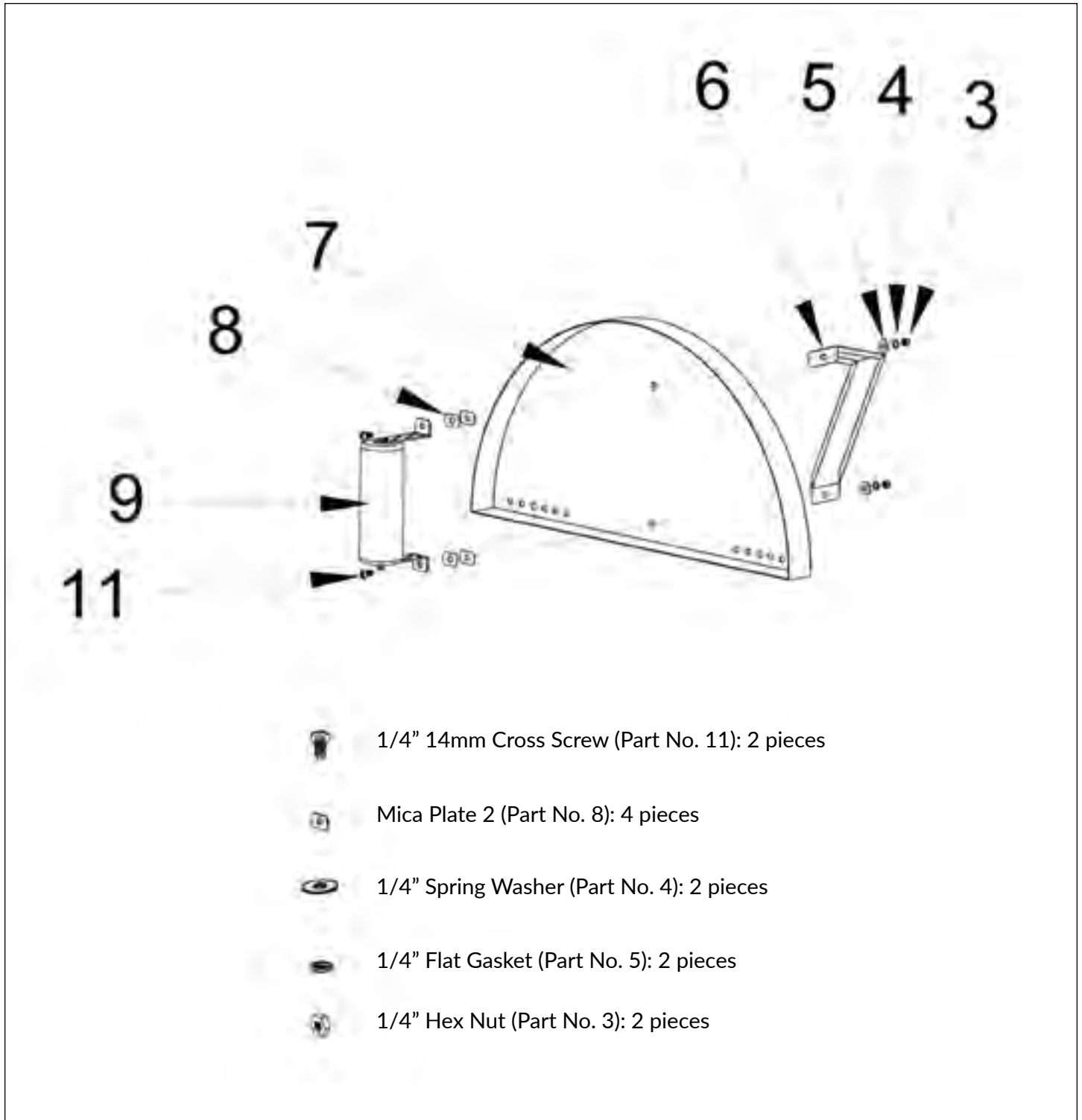

# INSTALLATION

## STEP 13

1. To prevent the door from accidentally opening, please ensure it is secured at the top by the hook mounted to the top of the door opening.
2. When working with gas burning, please remove the Dust Free Cover of Burner (Part No. 44). When working with wood burning, please insert the Dust Free Cover of Burner (Part No. 44), pay attention to placement direction.

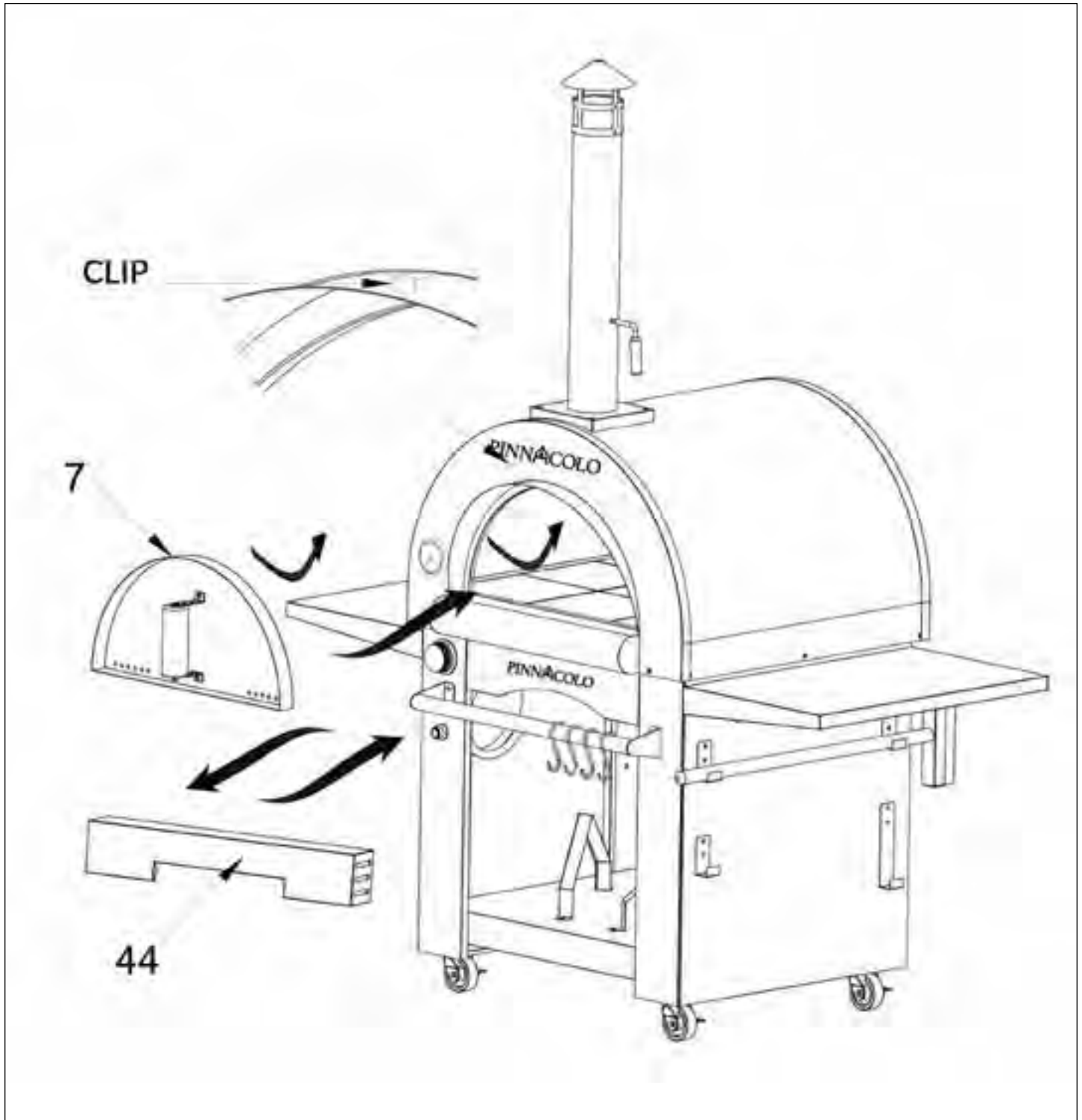

# LEAK TESTING

## GENERAL

Although all gas connections on the oven are leak tested at the factory prior to shipment, a complete gas leak check must be performed at the installation site due to possible mishandling in shipment, or excessive pressure unknowingly being applied to the unit. Periodically check the whole system for leaks following the procedures listed below. If the smell of gas is detected at anytime you should immediately check the entire system for leaks.

## BEFORE TESTING

Make sure that all packing material is removed from the oven including the burner tie-down straps.

**DO NOT SMOKE WHILE LEAK TESTING.**

**NEVER PERFORM LEAK TEST WITH AN OPEN FLAME.**

Make a soap solution of 1 teaspoon of liquid detergent to 1 cup of water. You will need a spray bottle, brush, or sponge to apply the solution to the fittings. For the initial leak test make sure it is full.

## TO TEST

1. Make sure the control valves are in the "OFF" position, and turn on the gas supply.
2. Check all connections with soap solution from the LPG regulator and supply valve up to and including the connection to the manifold pipe assembly (the pipe that goes to the burners). Soap bubbles will appear where a leak is present.
3. If a leak is present, immediately turn off the gas supply and tighten the leaky fittings.
4. Turn the gas back on and recheck.
5. Should the gas continue to leak from any of the fittings, turn off the gas supply and contact customer service at 437-777-7105 or sales@FireOneUp.com.



Only those parts recommended by the manufacturer should be used on the oven. Substitution will void the warranty. Do not use the oven until all connections have been checked and do not leak.

## GAS FLOW CHECK

Each oven burner is tested and adjusted at the factory prior to shipment. The flames of the burners should be visually checked.

Flames should be blue and stable with no yellow tips, excessive noise or lifting. If any of these conditions exist, check to see if the air shutter or burner ports are blocked by dirt, debris, spider webs, etc. If you have any questions regarding flame stability, please call customer service at 437-777-7105 or sales@FireOneUp.com.

**ALWAYS CHECK FOR LEAKS AFTER EVERY TANK CHANGE**

Check all gas supply fittings for leaks before each use. It is handy to keep a spray bottle of soapy water near the shut-off valve of the gas supply line. Spray all the fittings. Bubbles indicate leaks.

# GAS USE CAUTION

BEFORE USING YOUR GAS FIRED PIZZA OVEN, PLEASE FOLLOW THE INSTRUCTIONS BELOW.



## IF YOU SMELL GAS:

1. Immediately shut-off gas.
2. Extinguish flames.
3. Open the oven door.



**GAS LEAK COULD CAUSE FIRE OR EXPLOSIONS CAUSING SERIOUS INJURIES OR DAMAGES. IN CASE OF A GAS LEAK, DO NOT LIGHT THE OVEN AND DETERMINE THE REASON FOR THE LEAK IN ORDER TO PREVENT FIRE AND/OR EXPLOSION.**

Always use heat resistant utensils while cooking. Plastic spoons, forks, tongs, etc and other similar materials will not withstand the high temperatures in your oven and should be avoided.

Always keep children and pets away from the oven during use. The oven temperatures can be extremely high and can cause severe burns.

Keep fuel supply pipes far from hot surfaces.

The color of the oven surfaces can change due to high temperatures.

Do not use the oven in case of malfunction.

This oven has been designed only for outside use and should not be used in garages, porches, or verandas, enclosed or covered areas.

Never extinguish the flames with water.

Do not extinguish fires using water.

Do not use open flames near the oven.

Do not place empty gas tanks near the oven.

Do not paint or apply anything on the oven.

Please follow the instructions for the connection of the regulator.

After a prolonged period of non-use, please check for gas leaks or burner obstructions.

Any flammable materials must be at least 100 cm/39.3-in from the oven.

Should a grease fire occur, turn the gas off and close the oven door until the fire is out.

The liquefied petroleum gas (LPG) is not natural gas. The conversion or attempted use of natural gas in a LPG unit is dangerous and will void your warranty.

A rusty or dented gas tank may be hazardous. Do not use gas tanks with a damaged valve.

Even an apparently empty tank could still contain gas. The tank should be transported and stored accordingly.

During operation, use heat resistant mittens or cooking gloves.

All parts sealed by the manufacturer must not be tampered with.



# TIPS FOR GAS USE

The oven you have purchased may have some or all the feature listed below. The locations and appearances of the features shown here may not match your model.

## CONTROL PANEL

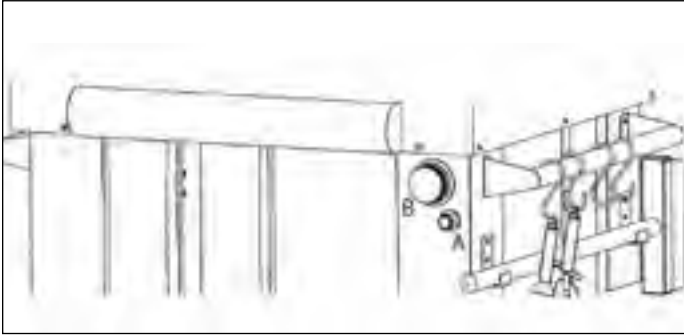

A. Battery (for Ignition) Box    B. Burner Knob

Any alteration of the product may be potentially hazardous.

Use only low pressure flexible pipes and regulators allowed by the current regulation. To replace the pressure regulators and flexible pipes, please refer only to the manufacturer instructions.

Check hose each time before using the oven for nicks, cracking, abrasions or cuts. If the hose is found to be damaged in any way, do not use the oven.

Move the oven door holding the wooden handle.

## LIGHTING

Check all gas connections for gas leaks before starting your oven.

Do not lean over the oven when lighting. Keep your face and body at least 50 cm/20-in away from the oven door. When lighting the oven, the oven door must be open.

The burner control knob must be in the OFF position before turning on the LPG tank valve.



1. Make sure burner knobs are turned to "OFF".
2. For gas oven using a propane tank, slowly open the tank valve.



**NOTE: If flow limiting device activates, your oven may not light. If your oven does not light, the flames will be low and will not heat properly. Turn tank valve and burner knob off and wait 30 seconds. After shutting off the tank, very slowly open tank valve and wait 5 seconds before lighting.**

3. Push in and turn the burner knob to IGNITE/HI. The burner will light immediately. When burner is lit, turn knob to desired setting.
  - If the flame does not light, turn the knob to the "OFF" position. Wait 3 minutes and try again.
  - Do not keep oven on at the maximum power for more than 20 minutes.
  - Do not exceed the limit temperature of 426°C/800°F.
  - During operation, never disconnect the gas regulator or other junctions.
  - Do not touch external surfaces and the chimney flue during oven operation.

# TIPS FOR GAS USE

## TO LIGHT THE OVEN WITH MATCH

If a burner will not light after several attempts using the control knobs, the burners may be lit with a match.

1. If you have already attempted to light the main burner with the igniter, allow 5 minutes for any accumulated gas to dissipate.
2. Insert a match into the lighting rod.
3. Strike the match to light it.
4. Gently hold the lit match close to the burner.
5. Push in and turn the control knob to IGNITE/ON. Hold this knob in for 15 seconds after the burner is lit. You will hear the “snapping” sound of the spark until after the knob is released.
6. If the burner does not light within seconds turn the knob to the “OFF” position, wait 5 minutes and try again.

### CAUTION

When using a match to light the oven make sure to use the extension rod.

### WARNING

When lighting, keep your face and hands as far away from the oven as possible.

### WARNING

Before lighting, please check all connections with proper procedure. If there is a leak, immediately turn off the gas!

### WARNING

This appliance will be hot during and after use. Use insulated oven mitts or gloves for protection from hot surfaces or splatter from cooking liquids.

### WARNING

Do not store a spare LPG tank under or near the appliance.

### WARNING

Never fill the tank beyond 80 percent full.

### WARNING

If the information in above warning is not followed exactly, a fire causing death or serious injury may occur.

# TIPS FOR GAS USE

## LPG TANK

The LPG is heavier than air. Any LPG leaks may collect in low areas and prevent dispersion.

The LPG tank must be installed, transported and stored in an upright position. LPG tanks should not be dropped or handled roughly.

Never place the replacement gas tank near the gas fired oven.

Never store or transport the LPG tank in places where temperatures can reach 50°C/112°F (they are too hot to hold by hand for example: do not leave the LPG tank in a car during a hot day).

Treat "empty" LPG tank with the same care as when full. Even when the LPG tank is empty, there still may be gas pressure in the tank. Always close the tank valve before disconnecting.

Be sure the regulator is assembled with the vent hole pointed downward so that it will not collect water. Make sure the vent hole is free of dirt, grease, insects, etc.

Check all gas connections for gas leaks before starting your oven.

Make sure the valve of the LPG tank or regulator is closed. The LPG tank must be stored away from any source of heat or ignition.

A. Connect the LPG tank.

- a) Screw the tank regulator (NOT included) turning clockwise (1). Position the regulator so that the vent hole (2) faces down.
- b) secure the tank regulator to the tank (3) (4).

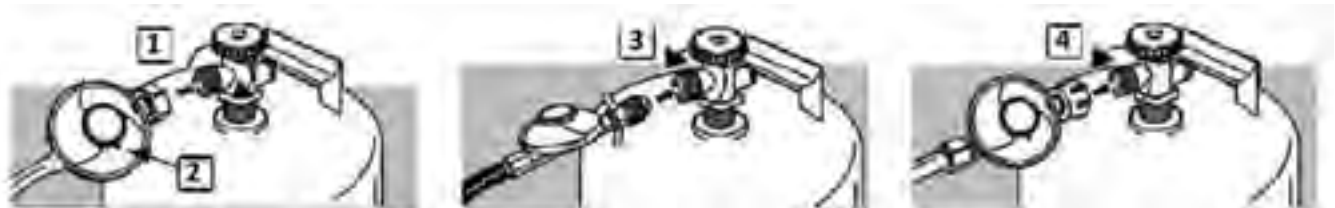

## WHERE TO KEEP THE OVEN

If the gas fired oven is not used, shut off and disconnect the tank.

The gas tank must be placed outside in well ventilated place and must be kept away from a child's reach.

The unused tanks must NOT be stored in buildings, garages or other enclosed places.

A statement:

1. Do not store a spare LPG tank under or near this appliance.
2. Never fill the tank beyond 80 percent full; and
3. If the instructions are not followed exactly, a fire causing death or serious injury may occur.

B. Place the tank on the floor behind the compartment.

C. Place the LPG tank so the valve opening faces the rear of the oven.

D. Connect the hosepipe to the junction (a) at the back of the oven.

Use pressure controlled adapter (NOT supplied) with a flow rate of 10kg/h and G30/G31 operation at 28..30/37 mbar, utilize a pipe ND 12 mm CE En14800.

It is advisable to change the gas hose every 2-3 years.

Do not twist the flexible gas hose. The length of the flexible hose should not exceed 1.5m/59-in.

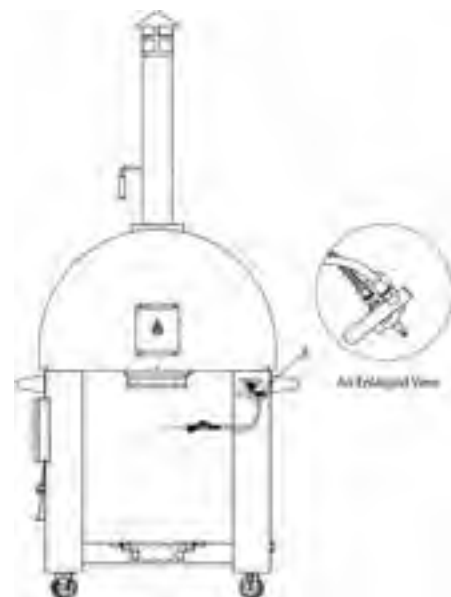

Tank Size: Height: 26-in Width: 12.5-in

# GAS COOKING

## COOKING

Always preheat your oven before cooking. Heat for 5-10 minutes or until the thermometer reaches 300-330°C/572-626°F.

Calculate a longer cooking time on cold or windy days or high altitudes. Calculate a shorter cooking time if the external temperature is particularly hot.

The cooking time depends on the weather conditions or the quantities, dimensions and shape of food.

Depending on the cooking condition, you may need to regulate the burner knob in order to reach the right cooking temperature.

- Switch off the gas fired oven and wait for it to cool down before cleaning.
- To clean the oven, don't use traditional oven detergents, abrasive detergents (kitchen detergents) or detergents containing citrus extracts, do not use abrasive steel wool.
- The gas burner must be cleaned periodically, and remove any food residue.

Make sure to not damage the valves and the burners during cleaning.

## ADVICE FOR COOKING PIZZA

Wait for around 15 minutes after lighting the oven, with the burner knob at maximum and the door closed to reach the optimum temperature for cooking an excellent Neapolitan pizza (with a higher moisture degree): air temperature of 400°C refractory floor temperature of 350°C.

Once the optimal temperature is reached, turn the burner to the minimum position and open the door. The oven will maintain a constant temperature and you can begin inserting the pizzas.

Check and remove any residual grease to avoid a grease fire.

While cooking, do not lean over the open oven or place hands or fingers on the front edge of the oven.

If the flames go out during cooking, turn off the gas knob and the gas tank knob. Wait five minutes before lighting up the oven again.

During operation the oven can reach high temperatures. Do not move the oven or leave it unattended while burning.

## IF THE OVEN COOLS DOWN TOO QUICKLY

The cause could be either from the first starting or starting the oven after a long period of inactivity.

Avoid making a small or fast fire that would not heat the oven to capacity.

Verify that water and/or humidity have not infiltrated the oven.

Please verify that the burner is working well, so close the door.

## IF THE OVEN DOES NOT COOK AS DESIRED

Check that the oven has reached the right temperature.

Make a fire with approximately 10 minutes of high flame.

Ensure the oven maintains the desired temperature for the duration of the cooking time; use the door to adjust the heat intensity as well as the flame adjuster: open and close the door to raise or lower the temperature as necessary.

# WOOD USE CAUTION

## GETTING STARTED

Carefully unpack your Wood-fired Pizza Oven, it's not too heavy, but use two people to lift it out of the box. Be sure to place the outdoor oven on the matched cabinet.

Remove all the protective film and discard. Assemble the cap/ chimney by sliding the ring hardware around the bottom of the cap, fit the chimney and cap together – secure by sliding the ring in position and tighten with a flat head screwdriver. Now slide the chimney pipe onto the top of the oven.



**HINT: Season the outdoor oven prior to use. Burn two or more times, allow the temp to reach 400°C and let the fire die out.**

**DO NOT OVERHEAT OVEN:** Extreme heat can permanently damage the outdoor oven. Bring the outdoor oven up to temp slowly. Start with a small fire in the center. Once established, move the fire to the LEFT side of the oven. Add small amounts of wood until the outdoor oven reaches even, high heat. A good temperature for pizza baking is when the cooking stone is at least 340°C.

**NEVER USE CHEMICAL FUEL STARTERS:** Only use a food safe fire starter, small kindling and newspaper to help start your fire. Starting fluids and other fire starters can foul the cooking surface and permanently damage the oven.

**NEVER USE CHEMICAL CLEANERS:** Only clean a cool oven. Only use a metal bristle brush or a damp cloth to clean the cooking stone.

## TIPS FOR WOOD USE

### CHOOSING YOUR WOOD

Use only dry hardwood such as oak and hickory. Avoid resinous wood such as pine or spruce. **NEVER USE TREATED LUMBER.** Below you'll find some information on different hardwoods most common in outdoor cooking.



**HINT: If the wood produces a lot of black smoke, it is generally an indication you are using the wrong type of wood.**

The type of wood used influences and accents the taste of your food. You may want to try the following hardwoods in your outdoor oven, if they are available to you.

<b>APPLE</b>	The flavor is milder and sweeter than hickory. Good with all meats.
<b>CHERRY</b>	Slightly sweet fruity smoke that's great with just about everything. Good with all meats.
<b>HICKORY</b>	The most common hardwood, sweet to strong, heavy bacon flavor. Good for all smoking, particularly pork and ribs.
<b>MESQUITE</b>	Sweeter and more delicate than hickory, it's a perfect complement to richly flavored meats such as steak, duck or lamb, but be careful as it can overpower.
<b>OAK</b>	Favorite wood of Europe, a mild smoke with no aftertaste. Oak gives food a beautiful smoked color. Good with red meat, pork, fish and big game
<b>PECAN</b>	Sweet and mild with a flavor similar to hickory but not as strong. Good for chicken, beef, pork and turkey.

## THE ART AND SCIENCE OF WOOD-FIRED COOKING

Cooking in your outdoor oven is much like using the oven in your home. You will quickly learn how to regulate the temperature, use different woods for flavor, and be amazed at how good the food tastes. Anyone can bake delicious pizza and bread, roast meat and vegetables, grill fish and seafood, and create mouthwatering desserts.

The cooking stone and dome of your outdoor oven give off radiant heat from all sides, creating a natural convection that bakes everything to perfection, while the fire on the side brings out a unique crisp and smoky taste. Any variety of oven-safe metal, ceramic or glass pan can be used to cook in your oven.



### WARNING

Keep ovenware away from flame and don't use in temperatures over 500°F. Always read and follow ovenware manufacturers usage instructions.

# WOOD COOKING

## FIRING UP YOUR OVEN

Your outdoor oven will bring years of enjoyment and countless delicious dishes once you have mastered the art of building and maintaining a fire that creates an evenly distributed, high-temperature cooking stone.



**HINT: Invest in a laser thermometer to show you the exact temperature inside your oven.**

Start the fire in the outdoor oven approximately one hour before cooking. Split wood into small pieces about 10" long by 1/2" thick. Using a food safe fire starter, kindling and newspaper, start a match lit fire within the stainless steel fire separator in the center of the cooking stone. Continue to feed the fire with two or three larger pieces until it becomes well established. At this point, slide the stainless steel fire separator and fire to the left side of the outdoor oven using the wire bristle broom included.



**HINT: It doesn't take much wood to bring the oven to 370°C on the thermometer.**

Close the oven door, vented enough to keep the flame burning, and continue to add wood as needed. The flame will reach the top of the dome and curve around to the other side; this is normal, just make sure the flames do not come out of the oven opening. The goal is for the cooking stone and dome to absorb the heat.

Once the cooking stone reaches between 340°C - 385°C you are ready to start cooking.

## High Temperature Cooking

When the oven stone is between 340°C - 385°C, you are at a perfect temperature to cook pizza. Pizzas are placed with the pizza peel on the cooking stone and take less than 3 minutes. Remember to rotate the pizza, to ensure even cooking.



**HINT:** A great trick to check if your pizza crust is fully baked, is to lift your pizza (while cooking) with the peel. If the pizza folds over the sides of the peel, the crust is not fully cooked.

## Medium Temperature Cooking

When the cooking stone is between 230°C - 315°C, you are at a good temperature to roast meat, vegetables, fish and seafood. Depending on the dish, you may want to cover it initially to allow it to cook fully before removing the cover for browning. You will also want to rotate the pans and roasts, alternating the side facing the fire.

## Grilling

It's a lot of fun and achieves great results, keeping things crisp on the outside but juicy on the inside, thanks to the convection flow of heat in the oven.

To grill, move the embers to the front- middle of the cooking stone, and place a freestanding grill grate over them (a cast iron grill grate with legs works the best). Now cook your steak, vegetables, fish and seafood the way you normally would when using a gas or charcoal grill.

## Low Temperature Cooking

When the cooking stone is between 160°C - 215°C, you are at a good temperature for baking breads, pies and desserts. Generally this is easiest to do after all of your cooking is complete, and by removing all the embers from the outdoor oven. Keep in mind that the outdoor oven will have to be pre-heated well in order to retain enough heat for cooking without fire. So make sure the cooking stone is 260°C or higher for at least 15 minutes before removing all the embers.

# TROUBLESHOOTING MAINTENANCE

## BURNER WILL NOT LIGHT

- Is the LPG tank valve turned off?  
*Turn the LPG tank on.*
- Is there gas in the LPG gas fuel tank?  
*Check the gas level.*
- Is the igniter working?  
*Check that the igniter battery is properly installed or check to see if the battery needs to be replaced. Check to see if the Burner will match-light. See “Manually Lighting the Main Burner” in the “Outdoor Burner Use” section. Check for loose wire connections to the igniter.  
*Check to see if debris is blocking the electrodes.  
If a spark occurs anywhere but the igniter tip, replace the igniter.**

## BURNER FLAME WILL NOT STAY LIT

- Is the gas supply fully turned on?  
*Check that the LPG tank valve is fully open*
- Is the gas supply in the LPG tank low?  
*Check the gas level*
- Is the burner properly installed and in good condition?  
*Check that the burner is installed properly. Check for defects in the burner.*

## FLAME IS NOISY, LOW OR ERRATIC

- Is the gas supply fully turned on?  
*Check that the LPG tank valve is fully open.*
- Is the gas supply in the LPG tank low?  
*Check the gas level*
- Does the burner appear low?  
*Check and clean the burner ports if clogged or dirty.*
- Is the gas supply hose bent or kinked?  
*Straighten the gas supply hose*
- Is the burner flame mostly yellow or orange?  
*Burner may be in an area that is too windy, or not receiving enough air. Check the burner air inlets for obstructions.*

## LOW HEAT

### LPG TANK:

For outdoor ovens using a LPG gas, slowly open the tank valve.



**NOTE: If flow limiting device activates, your burner may not light. If your burner does light, the flames will be low and will not heat properly.**

1. Turn tank valve and all control knobs off and wait 30 seconds.
2. After shutting off the tank, very slowly open the tank valve and wait 5 seconds before lighting.
3. Light the burners one at a time.

### MAINTENANCE FREQUENCY:

According to the frequency of use and habits, before using this product, you must first check whether there are cracks in the gas line, whether the ignition needle and the ignition needle thread are damaged, and the normal maintenance cycle should be checked once a week.

# HEATING AND CLEANING THE OVEN

Once the Outdoor Oven is cold, use the wire bristle broom to brush the cooking stone to remove all the ash and debris. Never extinguish the fire with water. Never use chemical cleaners. If you wish to clean the surface of your cooking stone, a damp cloth works best.



Close the oven door to get the oven really hot. Vent it enough to keep the flame burning. Add wood as needed.



Once the cooking stone is 340°C or higher, you are ready to start cooking entrees, desserts and pizzas.  
Do not overheat the oven.



Start a match lit fire in the stainless steel fire separator in center of oven. Once the fire is well established, push the fire to the left side with wire bristle broom.

## Thermometer

Clean with warm water, soap and a soft cloth.

## Oven

Remove any residual food from the burner with a brush.

**Do not enlarge burner orifices.**

## Stainless Steel Surfaces

Wash with a soft cloth and soapy water. Pay attention to follow the grain of the stainless steel. Do not use detergents with acids, or harsh chemicals of any kind. Rinse well after cleaning. Making the steel shine is very easy. Just wash it with soapy water, rinse out with water and dry properly. In case of resistant residuals, you can use a non-metal brush.

## HOW TO MAINTAIN THE STAINLESS STEEL

Making the steel shine is very easy. Just wash it with water and soap, rinse out with water and dry properly. In case of resistant residuals, it is possible to use a non-metal brush.

## COLD SEASON

We suggest you store the oven during the cold season in an enclosed dry area to protect it from weathering. Before storage, lightly lubricate the metal parts with oil in order to avoid corrosion. After storage, please check for any malfunction. Complete a full inspection and test for gas leaks before using following extended storage.



# SAFETY INSTRUCTIONS

## **⚠ WARNING**

Do not try lighting this appliance without reading the "LIGHTING INSTRUCTIONS" section of this manual.

TESTED IN ACCORDANCE WITH ANSI Z21.58-2018 • CSA 1.6-2018 STANDARD FOR OUTDOOR COOKING GAS APPLIANCE.  
THIS OVEN IS FOR OUTDOOR USE ONLY.

## OVEN INSTALLATION CODES

Check your local building codes for the proper method of installation. In the absence of local codes, this unit should be installed in accordance with the National Fuel Gas Code, ANSI Z223.1/NFPA 54, Storage and Handling of Liquefied Petroleum Gases, ANSI /NFPA B149.2 or CSA B149.1 Natural Gas and Propane Installation Code, and the National Electrical Code, ANSI/NFPA 70.

## CORRECT LPG TANK USE

LPG oven models are designed for use with a standard 9.07 kg (20 lb). Liquid Propane Gas tank, not included with oven. Never connect your gas oven to an LPG tank that exceeds this capacity.



**NOTE: The normal flow of gas through the regulator and hose assembly can create a humming noise. A low volume of noise is perfectly normal and will not interfere with operation of the oven. If humming noise is loud and excessive you may need to purge air from the gas line or reset the regulator excess gas flow device. This purging procedure should be done every time a new LPG tank is connected to your oven.**

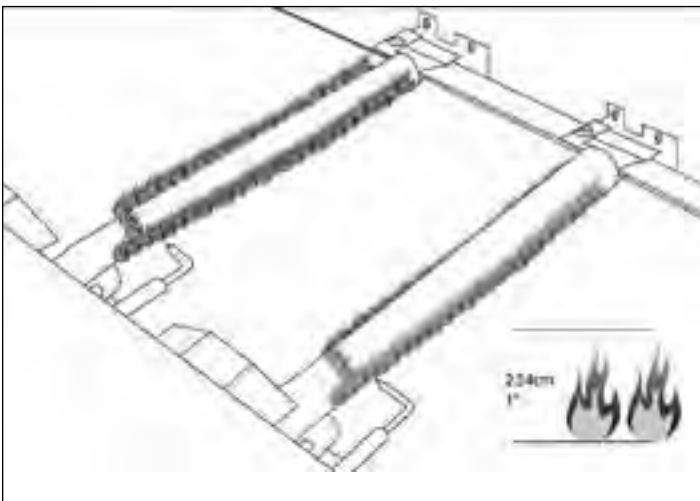

Visually check the burner flames prior to each use. The flames should look like this picture. If they do not, refer to the burner maintenance part of this manual.

## **⚠ CAUTION: BEWARE OF FLASHBACK**

**CAUTION:** Spiders and small insects occasionally spin webs or make nests in the oven burner tubes during transit and warehousing. These webs can lead to gas flow obstruction, which could result in a fire in and around burner tubes. This type of fire is known as "FLASH-BACK" and can cause serious damage to your oven and create an unsafe operating condition for the user.

Although an obstructed burner tube is not the only cause of "FLASH-BACK", it is the most common cause.

To reduce the chance of "FLASH-BACK", you must clean the burner tubes before assembling your oven, and at least once a month in late summer or early fall when spiders are most active. Also perform this burner tube cleaning procedure if your oven has not been used for an extended period of time. A clogged tube can lead to a fire beneath the oven.

# LIMITED WARRANTY

Fire One Up Sales Inc., the importer and distributor of the PINNACOLO PIZZA OVENS brand of Outdoor Ovens. Fire One Up Sales Inc warrants the Stainless Steel ovens and their components, including the body, floor, venting system, factory finish, stand and door (hereinafter referred to as the Product) to be free of defects in materials and workmanship for a period of one (1) year from time of purchase.

## Qualifications of the Warranty

The complete Product Warranty does not apply to the following:

1. The Product was not assembled or installed in accordance with the instructions or local building codes.
2. This Warranty does not cover any hairline cracking in the cordierite stones, or problems caused by extreme temperatures.
3. The Product has been subjected to non-standard or inappropriate use, including but not limited to tossing or throwing firewood into the oven with force, addition of non-approved accessories or cooking devices, or burning inappropriate or abnormal woods including; driftwood, coal, plywood and woods that have sap, include chemical treatment or are not designed for burning in an outdoor oven.
4. The Product has been subject to icing or wet-mopping while the oven is heating or during the cooling period, which can cause cracking or damage to the oven floor or metal components, or improper chemicals or liquids have been used to clean or sanitize the interior of the Product.
5. This Warranty does not cover any damage caused by storing any material either on top, below or inside of the Product.
6. The Warranty does not apply to normal wear and tear or any parts of the Product that would need replacing under the normal conditions including;
  - a. Normal or minor cracking due to expansion and contraction stress relief in the refractory materials, including but not limited to the cordierite stone.
  - b. Scratches to the exterior surface during normal use.
  - c. Any discoloration due to neglect, weather conditions, and any areas exposed to smoke or any aspect of the Product that may deteriorate as a result of normal use or aging.
7. This Warranty does not cover damage to, or failure of the Product, resulting from natural causes, or other catastrophic events, such a flood, freezing, fire, earth movement, wind or storms.

## Limitation of Liability

It is expressly agreed and understood that Fire One Up Sales Inc., sole obligation and the Purchaser's exclusive remedy under this Warranty, and under any other Warranty whether expressed or implied otherwise, shall be limited to replacement, repair, or refund up to the original purchase price of the Product, excluding shipping costs. Such liability shall not include, and Purchaser or other third parties, specifically renounce any rights to recover special, incidental, consequential, or other damages of any kind whatsoever, including, but not limited to, injuries to persons or damage to property, loss of profits or anticipated profits, damage to business reputation or goodwill, all costs incurred receiving,

unloading, moving at your location, and installing the Product, or loss of use of the Product.

In no event shall Fire One Up Sales Inc., or any reseller, business partner or associated business, be responsible for any incidental or consequential damages caused by defects in Products, whether such damage occurs, or is discovered before or after replacement or repair, and whether or not such damage is caused by Fire One Up Sales Inc. or its representatives. The direction of any Warranty with respect to this Product is limited to the legitimate claims received within the duration of the foregoing Warranty.

Warranty of replacement parts or Product shall only be from the original purchase date of the Product, not the date of repair or replacement covered under this Warranty. Parts to be replaced under the Warranty will be repaired or replaced with new or functionally sound parts at the discretion of Fire One Up Sales Inc. or their representative or designated service provider.

**NOTE:** Some Provinces or States do not allow the exclusion or limitation of incidental or consequential damages, or the duration of implied warranty, so the above exclusions or limitations may not apply to you.

## INVESTIGATION OF CLAIMS AGAINST WARRANTY

Fire One Up Sales Inc. reserves the right to investigate any and all claims against this Warranty and to decide upon the method of settlement.

Before any Product is returned, Fire One Up Sales Inc., or its authorized representative, must provide Purchaser with written return authorization and instruction for preparation of the shipment. Failure to properly package Product for return may result in Purchaser being billed by Fire One Up Sales Inc. Fire One Up Sales Inc. reserves the right to bill Purchaser for return freight if Product was found to be damaged through negligence or Warranty was voided, as outlined in this Warranty. Reference your original Terms of Sale Agreement for additional details.

## DEALERS HAVE NO AUTHORITY TO ALTER THIS WARRANTY

Fire One Up Sales Inc. employees and dealers have no authority to make any Warranties, nor to authorize any remedies in addition to, or inconsistent with, those stated above.

## HOW TO REGISTER A CLAIM AGAINST THE WARRANTY

In order for any claim under this Warranty to be valid, Fire One Up Sales Inc. must be notified to the claim defect by emailing (sales@fireoneup.com) or through the official chat access in the PINNACOLO PIZZA OVENS website.

All claims against this Warranty should include the Product Model, original invoice number, date of purchase, date of installation, a description of the defect, photographs or the area of concern, and a full description of the circumstances giving rise to the Warranty claim, if known. Please examine all of the contents of your delivery as soon as possible after receipt and inform Fire One Up Sales Inc. or the place of purchase within ten (10) days if any items are missing, incorrect or damaged.



# PINNACOLO™

---

PIZZA OVENS

By following the information within you can expect to  
ENJOY your PINNACOLO Pizza Oven and great tasting food,  
for many years to come!

Don't forget to share posts and stories on

**[PINNACOLOPIZZAOVENS.COM](https://www.pinnacolopizzaovens.com)**  
**[FIREONEUP.COM](https://www.fireoneup.com)**

