

# WHOLE HOUSE PREMIUM WATER TREATMENT SYSTEM

---

## INSTALLATION INSTRUCTION & OWNER'S MANUAL



---

**APEC WATER®**



[www.FreeDrinkingWater.com](http://www.FreeDrinkingWater.com)

All Rights Reserved © APEC Water Systems



**Please keep this Owner's Manual for future reference.**

**It contains useful information on how to maintain and care for your  
APEC Whole House Water Treatment System**

*Thank you for choosing APEC Whole House Water Treatment System.*

**Please read and become familiar with instructions and parts needed before proceeding with the installation.**

### **General Installation/Operation/Maintenance Requirements**

- Use a Licensed Plumber to Install this product.
- Check with your state and local public works department for plumbing and sanitation codes. You must follow these guidelines as you install the whole house water filter.
- This water filter system will withstand up to 90 psi water pressure. If your house's water pressure is higher than 90 psi, install a pressure reducing valve before the system is installed.
- DO NOT use with water that is microbiologically unsafe or of unknown quality without adequate disinfecting before or after.
- DO NOT install the water treatment system in an outside location or anywhere it will be exposed to direct sunlight.
- DO NOT install the water treatment system where temperatures gets to freezing.
- Manufacturer warranty can be voided if the installation requirements above are not met.

### **BEFORE INSTALLATION:**

**Inspect the system:** Please take the system and all the components out of the box. Inspect the system and all the connection fittings carefully, make sure nothing is damaged during shipping. If any part is cracked or broken, please do not proceed with the installation and contact APEC or your distributor for an exchange or diagnosis.

# Parts List for Whole House Backwashing Water Treatment System Installation Kit (3 packages):

**Package #1:** Filter timer control valve and system installation kit.



Filter timer control valve  
**X 1**

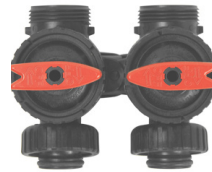

Bypass Valve  
**X 1**

**V3007-02LF kit includes:**



Brass Sweat Adapter Kit  
**X 2**



1" Quick Connect  
**X 2**



Plastic Split Rings  
**X 2**



Rubber O-rings  
**X 2**

**V3007 kit includes:**



Elbow Solvent Kit  
**X 2**



1" Quick Connect  
**X 2**



Plastic Split Rings  
**X 2**



Rubber O-rings  
**X 2**

**Drain line adapter:**



Option 1



Option 2

**Package #2:** Media tank and funnel.



Tank  
**X 1**

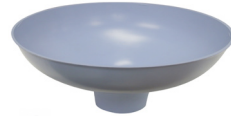

funnel  
**X 1**

**Package #3:** Water treatment system media.

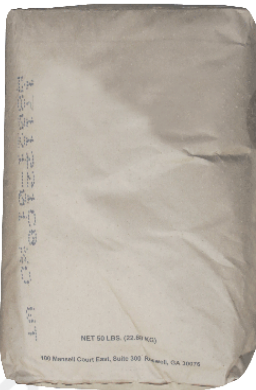

Water Treatment Media

The media weight varies from 27.5 lbs. to 55 lbs., depending on the system model.

**Plumbers Notice:** If this or any other system is installed in a metal (conductive) plumbing system, i.e. copper or galvanized metal, the plastic components of the system will interrupt the continuity of the plumbing system. As a result any errant electricity from improperly grounded appliances downstream or potential galvanic activity in the plumbing system can no longer ground through contiguous metal plumbing.

Older homes may have been built in accordance with building codes from decades ago some of which actually encouraged the grounding of electrical appliances through the plumbing system. Consequently, we highly recommend either the installation of a by-pass consisting of the same material as the existing plumbing, or a grounded “jumper wire” bridging the equipment and reestablishing the contiguous conductive nature of the plumbing system. Please ensure that your installation of the system comply with applicable state and local regulations.

**Well Water Locations:** Installation of this system will be after any and all well equipment, i.e. Well pump, Bladder tank, Pressure tank, etc.



## Preparing tank for installation instructions. Please follow installation steps below:

Step 1. Unscrew tank cap from the top of the tank (See **Figure. 1**). (Counterclockwise)



Figure. 1

Step 2. Place the funnel on the top of tank, and pour all of the media into the tank (See **Figure. 2**).



Figure. 2

Step 3. Once all of the media is installed, please remove the funnel and tube cover. **Very important (See Fig. 3).**

Step 4. Obtain the timer control valve and verify the o-ring is properly in place (See **Figure. 4A**).

Step 5. Screw the timer control valve tightly onto the top of the tank (see **Figure. 4B**) (Clockwise).

Step 6. Connect the timer control valve transformer into an electrical outlet and the system tank installation is complete.

**Your tank media is properly installed. Great job! Please continue with system installation on next page.**



Figure. 3



Figure. 4A



Figure. 4B

# INSTALLATION DIAGRAM

## Pre installation preparation:

The media in the water treatment system does not have to be pre soaked, however after the system is installed, please manually backflush the unit once before use. The timer control valve has been factory pre programmed to regenerate once a week, but you can set the regeneration time to your preference. You basically will just need to set up the time of day. Please refer to pages 5-6 to manually backflush the unit and general setup.

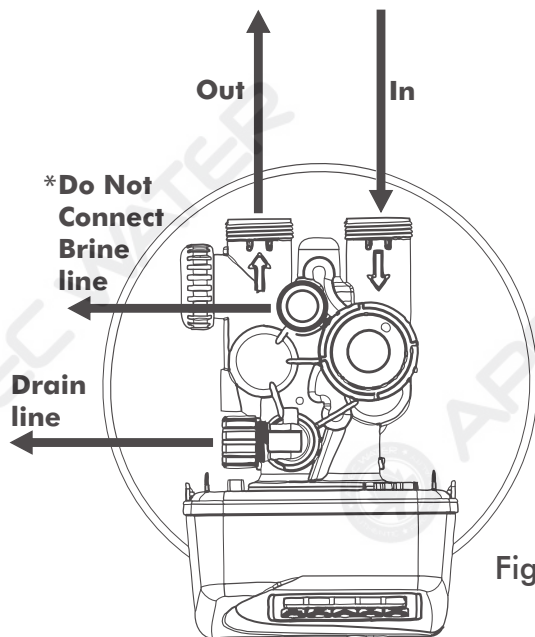

Figure. 5

**Please note:** The Control valve of the system only requires 3 connections. Inlet, Outlet and Drain Line.

**DO NOT** connect the Brine Line. The Brine line is only used when salt is needed like in a water softener application.

## Determine installation location for the system:

- A electrical outlet will be required for the system.
- Do Not install the units with less than 5-10 feet of piping between its outlet and the inlet of the water heater.
- Do Not install the units where the location is subjected to room temperatures under 34 degrees Fahrenheit.
- The tanks should be on a firm, level surface.
- Provided the drain line is not reduced, the drain line for the system should not exceed 5 feet Vertical. It is best to use a 1/2" ID (inner diameter) or larger drain line.

## SYSTEM TANK INSTALLATION

1. Turn off water supply where it enters the building.
2. The bypass valve comes complete with O-rings, split rings and black quick connector nuts. Install the bypass valve by pressing the valve onto the head of the tank and hand tighten both black quick connect nuts.
3. When running the piping for the system, connect the incoming water supply to the **DOWN-FLOW INLET** (Input) side. Connect the water supply line going into the house to the **UP-FLOW INLET** (Output) side. See **Figure. 6**

This is an overview for system installation.

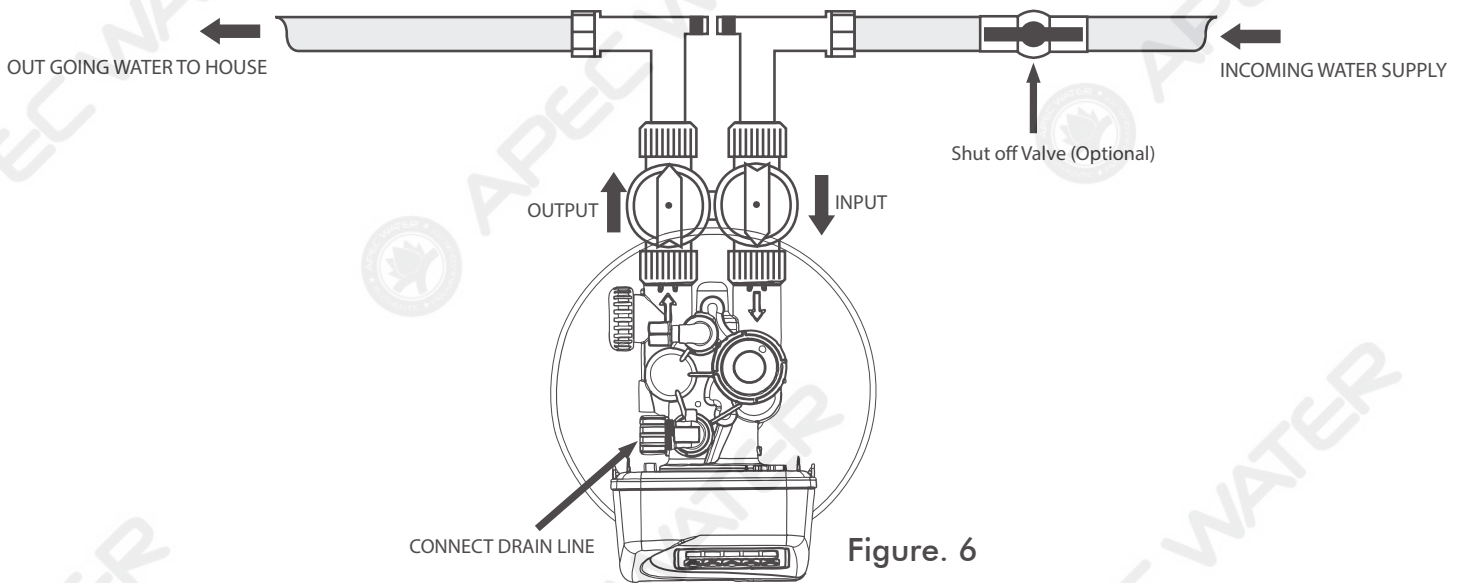

4. Use the appropriate fitting connection to the bypass valve. Brass Sweat Adapter Kit (WTS-ADPT-V300702LF) for copper piping and PVC Solvent 90 degree Adapter Kit (WTS-ADPT-V3007) for PVC Piping. (Follow the instructions supplied with the fittings for assemble).
  - a. Important: If soldering connections are used, do not install the O-rings, split rings and black quick connect fittings and piping. Allow solvent cements to set before installing the black quick connector nut, split ring and O-rings.
  - b. Important: If PVC solvent connections are used, use solvent cements and primers to connect fittings and piping. Allow solvent cements to set before installing the black quick connector nut, split ring and O-rings.
5. Please Set Time of Day on system control valve once installation is completed.



# SETTING UP TIMER CONTROL VALVE

## GENERAL OPERATION

When the system is operating one of two displays will be shown: time of day or days until next regeneration. Pressing ▲ or ▼ button will toggle between the two choices.

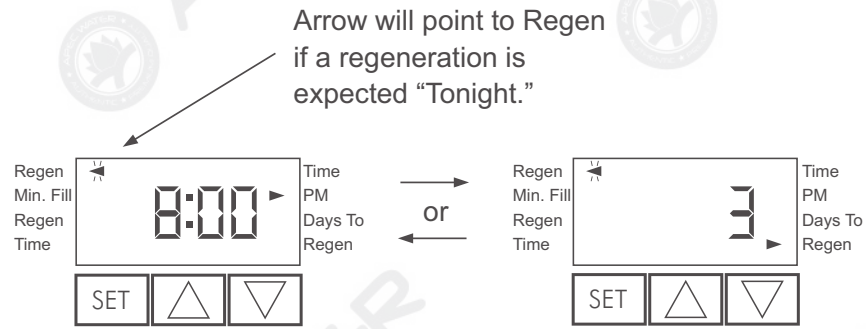

## TO SET TIME OF DAY

In the event of a prolonged power outage, time of day flashes, indicating that it needs to be reset. All other information will be stored in memory no matter how long the power outage. Please complete the steps as shown to the right. To access this mode, press "Set."

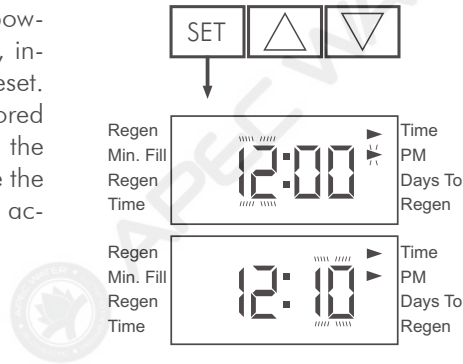

1. Accessed by pressing SET for approximately 3 seconds.
2. Adjust hour with ▲ or ▼ . With 60 Hz line frequency detection on power-up, timekeeping is 12 hour with PM indicator. With 50 Hz line frequency detection on power-up, timekeeping is 24 hour without the PM indicator. Press SET to go to the next step.
3. Adjust minutes with ▲ or ▼ .
4. Press SET to complete and return to normal operation.

## TO SET TIME OF REGENERATION AND DAYS BETWEEN REGENERATION

For initial set-up or to make adjustments, please complete the steps as shown. Access this mode by pressing SET and ▲ for approximately 3 seconds. The number of days between regenerations may need to be varied based on usage and water conditions. (This step will not appear if the 7-day clock option is selected.)

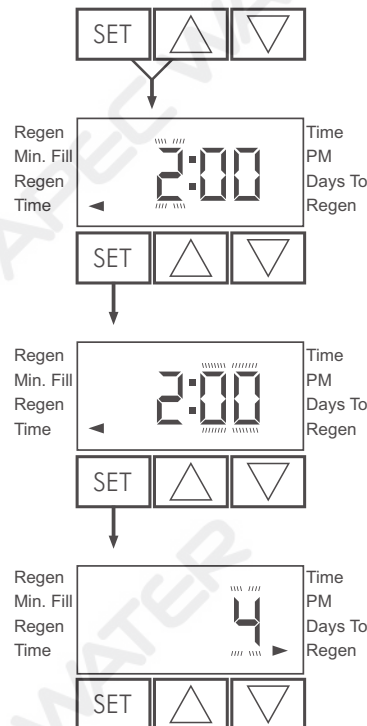

1. Accessed by pressing SET and ▲ simultaneously for about 3 seconds.
2. Set Regeneration Time Hour. Set the time for regeneration to start. Press SET to go to the next step.
3. Set Regeneration Time Minutes. Press SET to go to the next step.
4. Set number of Days between regeneration cycles.
5. Press SET to complete and return to normal operation.

## MANUAL REGENERATION

NOTE: If you need to initiate a manual regeneration, either immediately, or tonight at the pre programmed time (typically 2 a.m), complete the following steps.

Arrow will point to Regen if a regeneration is expected "Tonight."

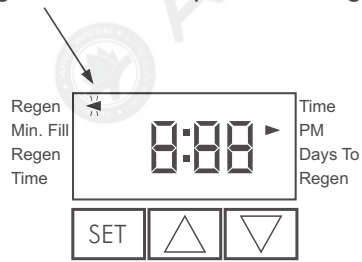

For Immediate Regeneration:  
Press and hold ▲ and ▼ simultaneously until valve motor starts (typically 3 seconds).

For Regeneration Tonight:  
Press and release ▲ and ▼ simultaneously (notice that arrow points to Regen).

## ERROR MESSAGES

If the display shows "E1," "E2," "E3", or "E4" (for error), call a service technician.



## POST INSTALLATION SYSTEM OVERVIEW

1. After the installation of the Whole House Water Treatment System, **CHECK FOR LEAKS**. If you notice water leaking at the control head, turn the head to tighten it up. The tank head is hand tighten, **do not** over tighten the head. **Do not** over tighten any of the fitting during installation. All fittings should be hand tightened.
2. The bottom of the tank is round, and uses the tank stand to stand the tank upright. If the tank leans to one side simply raise the tank in the air and set it on the ground until the tank stands vertical. You should do this before filling the tank with water, as the tank will be heavy when filled with water.
3. After installation the arrows on the bypass valve may be pointing in different directions than shown in our diagrams (See **Figure 7 & 8**). If this is the case simply pull up on the Red Arrows and turn them around.
4. Once the installation is complete, remove the protective film around the Stainless Steel tank jacket.

# SHUTTING OFF WATER TO THE SYSTEM FOR MAINTENANCE

To shut off water to the system, please position arrow handles as shown in the bypass operation diagram below. If your valve looks different compare to the diagram below, please follow the instruction #3 on the **Post Installation System Overview** section of the manual.

## Normal Operation

Treated Water Exits    Supply Water Enters

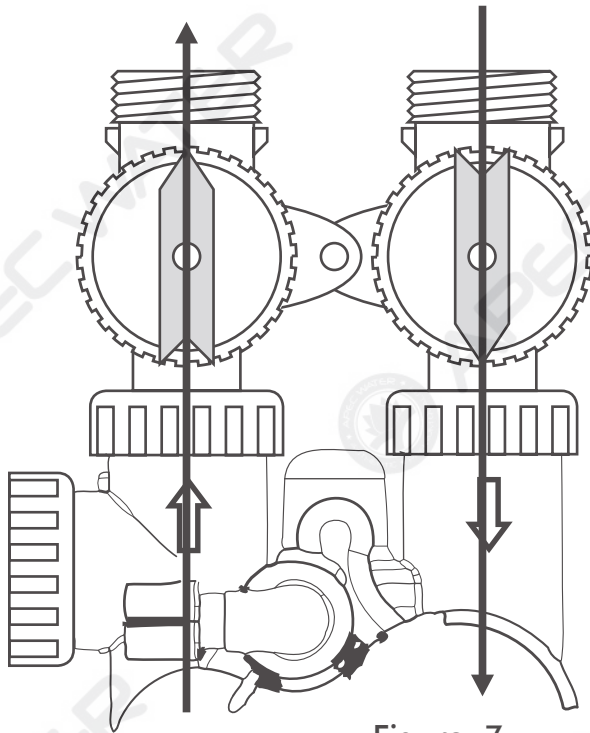

Figure. 7

## Bypass Operation

Supply Water Exits    Supply Water Enters

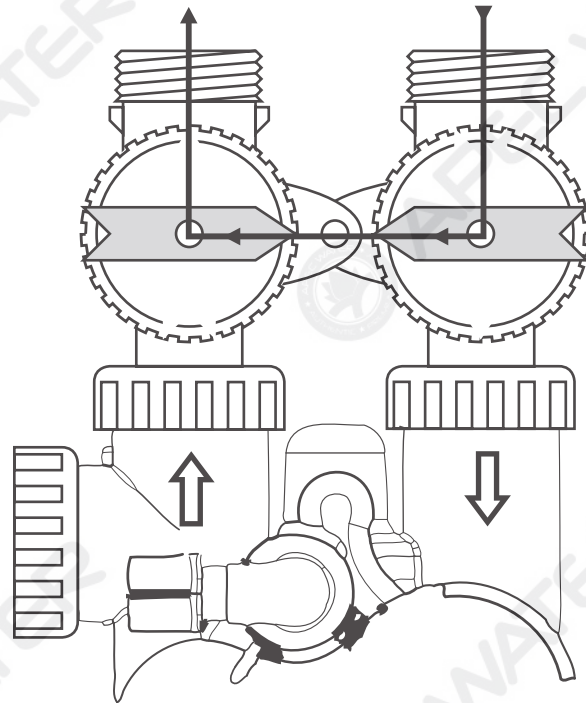

Figure. 8

**\*\*\* END OF INSTALLATION MANUAL \*\*\***

# LIMITED PRODUCT WARRANTY

## Scope

APEC takes pride in selling a superb line of products, including this Whole House Water Filtration ("Product"). As such, APEC expressly warrants to the original purchaser that, for a period of ten (10) years from the date of purchase, its tanks, valves, in/out non-electric heads, bypasses and fittings will be free from defects in material and workmanship. Within that ten (10) year period from the original purchase, APEC will, at its option, repair or replace the Product without charge, or refund the cost of the Product, if the Product fails or does not perform as warranted solely due to a manufacturing defect within the warranty period, subject to the limitations and exclusions set forth in this Limited Product Warranty. This Limited Product Warranty only applies when the Product is used, stored, handled, fabricated and/or installed in the manner recommended by APEC in the Installation Instruction & Owner's Manual ("Manual").

Note: APEC Water warrants to the customer that its solid-state electronic heads (if applicable) will be free from defects in material and workmanship under normal use and service for a period of five (5) years.

## Repair or Replacement

Repair or replacement during this ten (10) year and five (5) year warranty shall include reasonable labor charges necessary to repair or replace the defective Product, but shall not include freight charges or any other local labor charges from third parties other than APEC, unless APEC expressly approves such charges in writing. During the entire ten (10) year and five (5) year warranty, APEC's obligation to repair or replace shall further be limited to repair or replacement with the styles, models, products, colors, etc. of the Product that are available at the time of the repair or replacement, and shall be limited to the repair or replacement of only the specific Product that fails due to a manufacturing defect. Any repaired or replaced product shall also remain subject to the original ten (10) year and five (5) year warranty from the date of the original purchase, and any repair or replacement shall not extend the original warranty period in any manner or start a new warranty period.

## Conditions of Validity of this Limited Product Warranty

Even though the Product has extremely high endurance for operating conditions such as pH, maximum TDS, temperature, and optimum water pressure, THIS LIMITED PRODUCT WARRANTY SHALL ONLY BE VALID IF:

1. The replaceable media is changed and maintained on a regular basis as directed in the Manual. Moreover, depending on local water input water quality, regular maintenance may need to be increased.
2. The Product is operated within the confines of its suggested operating conditions:

Any information or suggestion by APEC with respect to the Product concerning applications, specifications or compliance with codes and standards is provided solely for your convenient reference and is made without any representation as to accuracy or suitability. You must verify and test the suitability of any information with respect to the Product for your specific application.

## Non-Covered Defects

THIS LIMITED PRODUCT WARRANTY DOES NOT COVER DEFECTS CAUSED BY:

1. Improper storage, installation, maintenance, handling, use and/or alterations of the Product, including, but not limited to, non-compliance with the installation, maintenance and standard operation conditions stated in the Manual and this Limited Product Warranty.
2. Unreasonable use, unintended use, or misuse of the Product for something other than its intended purpose as a whole house water filtration system.
3. Use of replacement parts, media, or other accessories that are not sold or manufactured by APEC for use with this particular Product.
4. Damage not resulting from manufacturing defects that occur while the Product is in the original purchaser's possession.
5. Installation of the Product with known or visible manufacturing defects at the time of installation.
6. Damage caused by freezing, flood, fire or Act of God.

## CONDITIONS THAT RENDER THIS LIMITED PRODUCT WARRANTY VOID

THIS LIMITED PRODUCT WARRANTY SHALL BE VOID IF:

1. The Product is not operated in compliance with normal municipal water conditions for which the particular model of this Product is intended.
2. The person seeking to invoke the warranty is not the original purchaser. That is, this Limited Product Warranty only extends to original purchasers.
3. The Product is purchased used. That is, this Limited Product Warranty only covers new products.
4. The Product is purchased from someone other than APEC or one of APEC's authorized dealers. This is because, unless the Product was sold by APEC or one of its authorized dealers, APEC cannot verify or guarantee the integrity or authenticity of the Product.

### General Conditions

The warranties set forth herein are the only warranties made by APEC in connection with the product. APEC cannot and does not make any implied or express warranties with respect to the product, and disclaims all other warranties, including, but not limited to, any warranty of merchantability or fitness for a particular purpose. Products sold by APEC are sold only to the specifications specifically set forth by APEC in writing. Other than the limited product warranty set forth herein, APEC makes no other warranties, express or implied. APEC's sole obligation under this warranty shall be repair or replacement of a non-conforming product or parts of the product, or at the option of APEC, return of the product and a refund of the purchase price. Buyer assumes all risk whatsoever as to the result of the use of the product purchased, whether used singularly or in combination with any other products or substances.

No claim by the buyer/owner of any kind, including claims for indemnification, shall be greater in amount than the purchase price of the products in respect to which damages are claimed. In no event shall APEC be liable to buyer/owner in tort, contract or otherwise, for any special, indirect, incidental, consequential, reliance, statutory, special, punitive or exemplary damages, including, but not limited to, lost profits, loss of use, loss of time, inconvenience, damage to good will or reputation, or loss of data, even if advised of the possibility of such damages or such damages could have been reasonably foreseen, in connection with, arising out of, or as a result of, the sale, delivery, servicing, use or loss of use of the products sold hereunder, or for any liability of buyer to any third party with respect thereto.

### Obtaining Warranty Coverage or General Inquiries

If coverage is available, you may obtain coverage under this Limited Product Warranty by providing APEC with proof of original purchase, and that you are the original purchaser. For service under this Limited Product Warranty, you must notify APEC by phone at 1-800-880-4808, by email at [techsupport@freedinkingwater.com](mailto:techsupport@freedinkingwater.com), or in writing at 301 Brea Canyon Road, City of Industry, CA 91789. In making the claim, please provide your name, address, phone number, a description of the product involved, and an explanation of the defect.

### California Proposition 65 Warning

 **WARNING:** This product contains chemicals known to the State of California to cause cancer or birthdefects or other reproductive harm. For more information go to [www.P65Warnings.ca.gov](http://www.P65Warnings.ca.gov).



**APEC WATER®**

**[www.FreeDrinkingWater.com](http://www.FreeDrinkingWater.com)**

301 Brea Canyon Road  
City of Industry, CA 91789  
1-800-880-4808

© This manual is copyrighted by APEC Inc. Under the copyright laws, this manual may not be reproduced in any form, in whole or part, without the prior written consent of APEC Inc.  
Manual print Ver.3.1, 2023 Sept.

