

Tank RV Water Heater

Installation and Operation Manual

**WARNING**

If the information in these instructions is not followed exactly, a fire or explosion may result causing property damage, personal injury or death.

- Do not store or use gasoline or other flammable vapors and liquids in the vicinity of this or any other appliance.
- WHAT TO DO IF YOU SMELL GAS
 - Evacuate all persons from the vehicle.
 - Shut off the gas supply at the gas container or source.
 - Do not touch an electrical switch, or use any phone or radio in the vehicles.
 - Do not start the vehicle's engine or electric generator.
 - Contact the nearest gas supplier or qualified service technician for repairs.
 - If you can not reach a gas supplier or qualified service technician, contact the nearest fire department.
 - Do not turn on the gas supply until the gas leak(s) has been repaired.
- Installation and service must be performed by a qualified installer, service agency or the gas supplier.



WARNING

If the information in these instructions is not followed exactly, a fire or explosion may result causing property damage, personal injury or death.

- Do not store or use gasoline or other flammable vapors and liquids in the vicinity of this or any other appliance.
- WHAT TO DO IF YOU SMELL GAS
 - Evacuate all persons from the vehicle.
 - Shut off the gas supply at the gas container or source.
 - Do not touch an electrical switch, or use any phone or radio in the vehicles.
 - Do not start the vehicle's engine or electric generator.
 - Contact the nearest gas supplier or qualified service technician for repairs.
 - If you can not reach a gas supplier or qualified service technician, contact the nearest fire department.
 - Do not turn on the gas supply until the gas leak(s) has been repaired.
- Installation and service must be performed by a qualified installer, service agency or the gas supplier.

Please read these instructions carefully and follow all instructions, guidelines, and warnings included in this product manual in order to ensure that you install, use, and maintain the product properly at all times. These instructions **MUST** stay with this product. By using the product, you hereby confirm that you have read all instructions, guidelines, and warnings carefully and that you understand and agree to abide by the terms and conditions as set forth herein. You agree to use this product only for the intended purpose and application and in accordance with the instructions, guidelines, and warnings as set forth in this product manual as well as in accordance with all applicable laws and regulations. A failure to read and follow the instructions and warnings set forth herein may result in an injury to yourself and others, damage to your product, or damage to other property in the vicinity. This product manual, including the instructions, guidelines, and warnings, and related documentation, may be subject to changes and updates.

CONTENTS

1 Explanation of Symbols and Safety Instructions	01
1.1 Recognize Safety Information	01
1.2 Understand Signal Words	01
1.3 Supplemental Directives	01
1.4 General Safety Messages	01
2 Intended Use	01
3 General Information	02
3.1 Unit Specifications	02
3.2 Component Locations	03
3.3 Technical Parameters	04
4 Installation	05
4.1 Preparing the Installation Location	05
4.2 Blocking the Water Heater	06
4.3 Installing the Water Hose	06
4.4 Installing The Gas Line	07
4.5 Installing The Wired Controller	07
4.6 Wiring the 120 VAC Power Supply	08
4.7 Wiring the 12 VDC Power Supply	08
4.8 Installing The Unit	09
4.9 Performing Leak Testing	09
5 Operation	10
5.1 Operating instructions	10
5.2 Wired controller operation	10
5.3 THERMOSTAT MANUAL RESET	11
5.4 Shutting Down the Water Heater	11
5.5 High altitude use	11
6 Maintenance And Care	12
6.1 Performing Preventative Maintenance	12
6.2 Electronic Ignition Module Cleaning	12
6.3 Maintaining the Water Heater Tank	13
6.4 Servicing the T&P Relief Valve	14
6.5 Using After-Market Water Heating Element Devices	15
7 Troubleshooting	16
7.1 Fault description and troubleshooting	16
7.2 Non-defect when the following conditions occur	16
8 Wiring Diagrams	17
9 Replacement parts: components	19
10 Disposal	20

1 Explanation of Symbols and Safety Instructions

This manual has safety information and instructions to help you eliminate or reduce the risk of accidents and injuries.

1.1 Recognize Safety Information

 This is the safety alert symbol. It is used to alert you to potential physical injury hazards. Obey all safety messages that follow this symbol to avoid possible injury or death.

1.2 Understand Signal Words

A signal word will identify safety messages and property damage messages, and also will indicate the degree or level of hazard seriousness.



DANGER

Indicates an imminently hazardous situation which, if not avoided, will result in death or serious injury.



WARNING

Indicates a hazardous situation that, if not avoided, could result in death or serious injury.



CAUTION

Indicates a hazardous situation which, if not avoided, could result in property damage and minor or moderate injury.



NOTICE

This symbol indicates important information where there is no risk to people or property.

1.3 Supplemental Directives

To reduce the risk of accidents and injuries, please observe the following directives before proceeding to install or operate this appliance:

- Read and follow all safety information and instructions.
- Read and understand these instructions before installing, operating, or servicing this product.
- Installation and service must be performed by a qualified Service Technician, Service Center, OEM, or Gas Supplier.
- The installation must comply with all applicable local or national codes, including the latest edition of the following standards:

U.S.A.

- ANSI/NFPA70, National Electrical Code (NEC)
- ANSI/NFPA 1192, Recreational Vehicles Code
- ANSI Z223.1 National Fuel Gas Code
- Federal Mobile Home Construction & Safety Standard, Title 24 CFR, part 3280, or when this Standard is not applicable, the Standard for Manufactured Home Installations (Manufactured Home Sites, Communities and Set-Ups), ANSI A255.1
- ANSI Z21.10.1, Gas Water Heaters
- A119.5, Park Trailers

Canada

- CSA C22.1, Parts I & II, Canadian Electrical Code
- CSA Z240 RV Series, Recreational Vehicles
- CAN/CGA B149 Installation Codes
- CAN/CSA-Z240 MH Series, Mobile Homes
- CSA 4.1 (latest edition)

1.4 General Safety Messages



WARNING

This product can expose you to lead, which is known to the state of California to cause cancer and birth defects or other reproductive harm. For more information, go to www.P65warnings.ca.gov.



WARNING: FIRE AND/OR EXPLOSION HAZARD

Failure to obey the following warnings could result in death or serious injury:

- Follow the information in this manual exactly.
- Do not store or use gasoline or other flammable vapors and liquids in the vicinity of this or any other appliance.



WARNING: BURN HAZARD, FIRE, EXPLOSION, AND/OR CARBON MONOXIDE HAZARD.

Keep the water heater area clear of combustible cleaning materials, gasoline, and other flammable vapors and liquids. Failure to obey this warning could result in death or serious injury.

2 Intended Use

This Water Heater is designed and intended for use in a recreational vehicle (hereinafter referred to as "RV") for which it is supplied. This product is designed to heat water and is not intended to be used as a space heater for hydronic heating. This Water Heater is only suitable for the intended purpose and application in accordance with these instructions.

This manual provides information that is necessary for

proper installation, operation, and maintenance of the Water Heater. Poor installation and/or improper operating or maintenance will result in unsatisfactory performance and a possible failure. The manufacturer accepts no liability for any injury or damage to the product resulting from:

- Incorrect assembly or connection, including excess voltage.
- Incorrect maintenance or use of spare parts other than original spare parts provided by the manufacturer.
- Alterations to the product without express permission from the manufacturer.
- Use for purposes other than those described in this manual.

Kingver reserves the right to change product appearance and product specifications.

3 General Information

This section provides reference information regarding the recommended installation tools and materials, the unit components, and the model identification associated with the different water heater models.



NOTICE

The images used in this document are for reference purposes only. Components and component locations may vary according to specific product models. Measurements may vary ±0.38 in. (10 mm).

3.1 Unit Specifications

Model	A	B	C	D
KRVGE-HS6	15.0 in (380mm)	15.0 in (380mm)	21.6 in (548mm)	12.8 in (325.5mm)
KRVGE-HS10	18.5 in (470mm)	18.5 in (470mm)	21.0 in (532.5mm)	16.3 in (414mm)

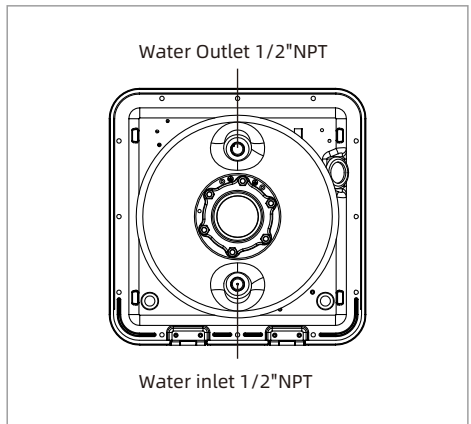
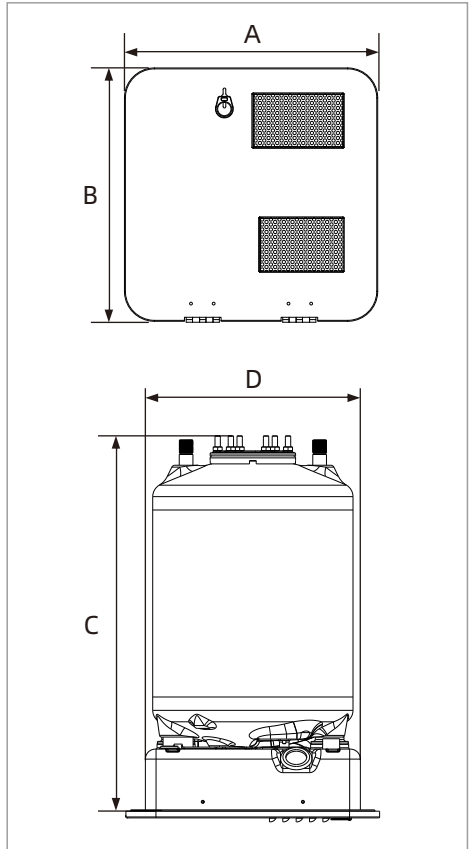

3.2 Component Locations

This section provides the component locations for each Water Heater model.

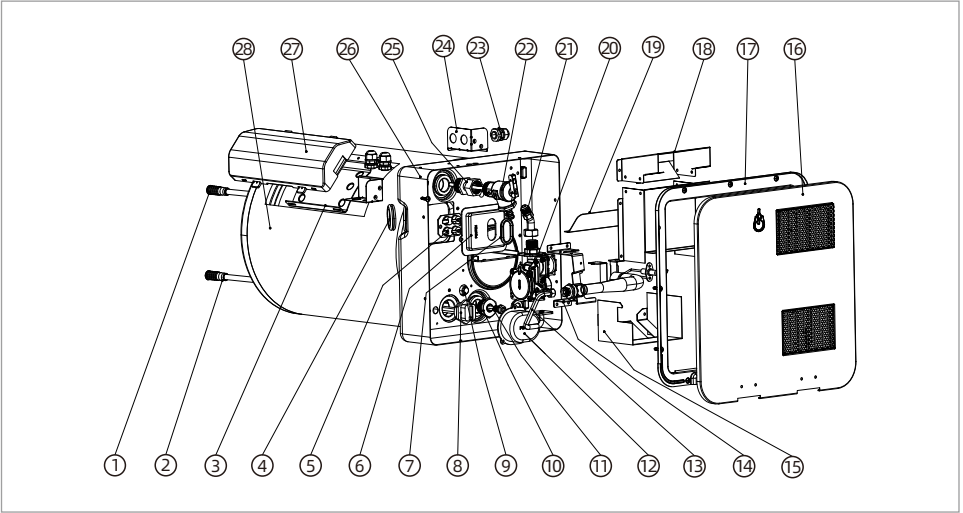

- | | |
|---|---|
| ① Water level pipe | ⑮ Diversion hood |
| ② Water diffuser | ⑯ Panel assembly |
| ③ Controller bracket | ⑰ Cabinet flange cover |
| ④ Gas inlet pipe protection ring | ⑱ Exhaust hood |
| ⑤ Thermostat | ⑲ Deflector |
| ⑥ Thermostat cover | ⑳ Regulator valve |
| ⑦ Rubber grommet | ㉑ Gas inlet fitting assembly |
| ⑧ Heating tube | ㉒ Temperature and Pressure Relief Valve |
| ⑨ Temperature probe | ㉓ Bundle coil |
| ⑩ Electronic titanium rods adapter | ㉔ Main housing |
| ⑪ Electronic titanium rods (magnesium anode rods) | ㉕ TP relief valve adapter |
| ⑫ Heat pipe covers | ㉖ Metal shell |
| ⑬ Gas inlet tube assembly | ㉗ Controller box |
| ⑭ Regulator valve support | ㉘ Water storage tank |

3.3 Technical Parameters

Water Heater Specifications Table

Model		KRVGE-HS6	KRVGE-HS10
Part no.		KRVGE-HS6BW	KRVGE-HS10AW
Capacity (Gallons)		6 gallons	10 gallons
Range of adjustment		104 °F (40 °C); 122 °F (50 °C); 140 °F (60 °C);	
Max. Heat Input (Btu/hr)		12,000	12,000
Orifice Drill Size		40mil for LPG	
Max. Inlet Gas Pressure		13" wc (3.23 kpa)	
Min. Inlet Gas Pressure		8" wc (1.99 kpa)	
Total Input Current (A)		< 16	
Rated Gas Inlet Pressure		LPG 11" wc 2.74 kpa	
Ignition method		Pulse continuous ignition	
Connector Specification	Gas inlet	5/8" UNF	
	Cold water inlet	1/2" NPT	
	Hot water outlet	1/2" NPT	
Electric supply		AC 120 V / 60 Hz	
Rated gas heating electric power (W)		7W ± 1W	
Rated electric heating power (W)		1440 W	
Max. Temperature		140 °F (60 °C)	

4 Installation



DANGER: CARBON MONOXIDE POISONING HAZARD.

This product can produce carbon monoxide, which has no odor and can be life-threatening. Avoid improper adjustment, alterations, service, or maintenance. Follow instructions for the proper installation of this appliance. Failure to obey this danger notification can result in improper installation causing carbon monoxide poisoning that will result in death or serious injury.



WARNING: FIRE AND/OR ELECTRICAL SHOCK HAZARD.

Failure to obey the following warnings could result in death or serious injury:

- Make sure there are no obstacles (wires, pipes, etc.) inside of the RV roof or walls at the installation locations.
- Shut off the gas supply, disconnect the 120 VAC power from RV, and disconnect the positive (+) 12 VDC terminal from supply battery before drilling or cutting into the RV.



WARNING: ELECTRICAL GROUNDING INSTRUCTIONS.

This appliance is equipped with a three-prong (grounding) plug for your protection against shock hazards and should be plugged directly into a properly grounded three-prong receptacle. Do not cut or remove the grounding prong from this plug. Failure to obey this warning could result in death or serious injury.

This section describes how to install the Water Heater and control switch. Please consider the following directives prior to beginning installation:

- This appliance must be installed by a qualified professional installer.
- The water heater tank must be supported at the same level as the bottom of the sidewall cutout. Provide adequate clearance at the rear of the unit for easy service access to the water connections.
- If the appliance is installed where a connection or tank leakage can damage an adjacent area, install a drain pan (which can be drained outside of the RV) under the Water Heater.
- To install the Water Heater on carpeting, install the Water Heater onto a metal or wood panel that extends at least 3 in. (7.62 cm) beyond the total width and depth of the Water Heater.

4.1 Preparing the Installation Location

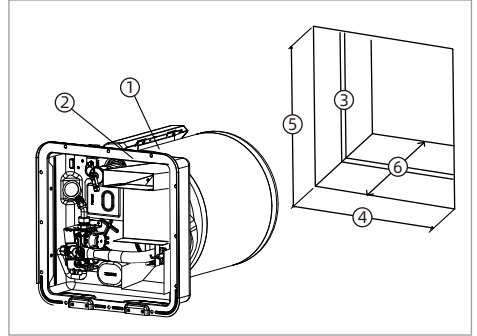

- ① Water Heater
- ② Flange
- ③ Cutout Frame
- ④ Cutout Width
- ⑤ Cutout Height
- ⑥ Cutout Depth

1. Plan the location of the Water Heater within the RV.
2. Erect the side walls and cut the square opening. Refer to the following tables for cutout and clearance specifications for basic water heater models.

Model	Cutout Width	Cutout Height	Cutout Depth
KRVGE-HS6	13.0 in (330 mm)	13.0 in (330 mm)	21.6 in (548 mm)
KRVGE-HS10	16.5 in (419 mm)	16.5 in (419 mm)	21.0 in (532.5 mm)

The cutout width and height tolerance is $\pm 1/8$ in. (± 3.0 mm) on all models.

The following table shows the requirements for the minimum clearance from combustible construction.

Sides	Back	Top	Bottom
0 in (0 mm)	0 in (0 mm)	0 in (0 mm)	0 in (0 mm)

The following figure and table show the minimum required clearances between the water heater vent and any projection or plastic part on the side of the RV.

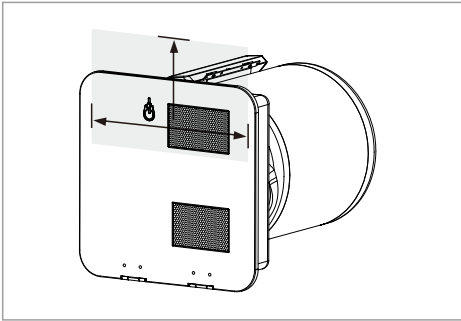

Sides	Top
3 in (7.62 mm)	12 in (13.48 mm)

3. Frame the cutout with 2 x 2 lumber or equivalent.
4. Bend all flanges 90° along the scored lines.
5. Block the Water Heater.

4.2 Blocking the Water Heater

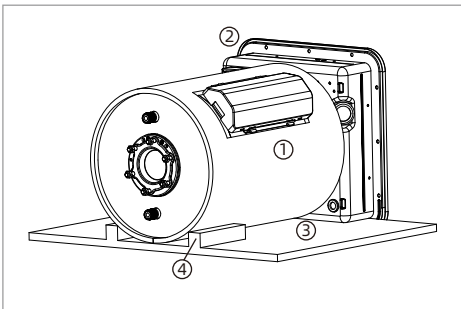

- ① Water Heater ② Cutout Frame
③ Floor ④ Wood Block

1. Place the Water Heater into the cutout location.
2. At the back of the cutout, measure the distance between the side of the cutout and the side of the Water Heater.
3. Remove the Water Heater from the cutout location.
4. Mark the appropriate measured distance taken in step 2 on each side along the back of the cutout.

5. Place a block of 2 x 2 lumber (minimum) that is at least 6 in. (15 cm) long at each marked location.
6. Secure the wood blocks to the floor.

4.3 Installing the Water Hose

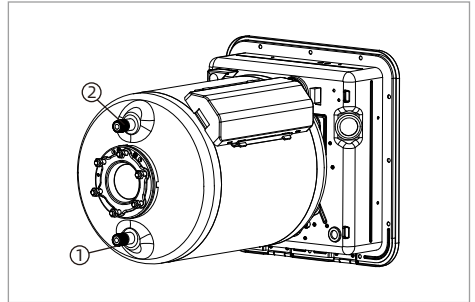

- ① Cold Water Inlet ② Hot Water Outlet

1. Position the Water Heater onto the planned location on the floor of the RV.
2. Remove the thread protector from the 1/2 in. (1.27 cm) hot water outlet.
3. Apply pipe sealant to the threads of the 1/2 in. (1.27 cm) National Pipe Tapered (NPT) hot water outlet hose.
4. Connect the 1/2 in. (1.27 cm) (NPT) hot water outlet hose to the proper fitting on the Water Heater using a suitable fitting.



NOTICE

Allow flexibility in the water and gas hoses so you can pull the unit forward through the wall 1 in(2.54 cm) past the skin.

5. Remove the thread protector from the 1/2 in. (1.27 cm) cold water inlet.
6. Apply sealant to the threads of the 1/2 in. (1.27 cm) (NPT) cold water inlet hose.
7. Connect the 1/2 in. (1.27 cm) (NPT) cold water inlet hose to the proper fitting on the Water Heater using a suitable plastic fitting.

4.4 Installing The Gas Line

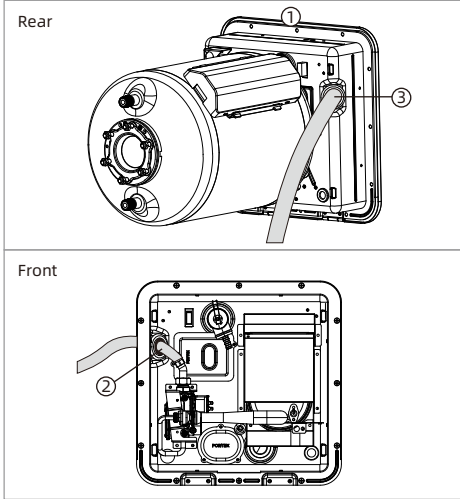

- ① Water Heater
- ② Over the line sheath
- ③ Gas Line

1. Connect the 5/8 in. (15.87 mm) flared L.P. gas line to the Water Heater.
2. Slide the grommet onto the 5/8 in. (15.87 mm) tubing.
3. Flare the gas line as necessary.



NOTICE

If the 5/8 in. (15.87 mm) gas line is already flared, cut the grommet on one side. Place the split grommet over the gas line and press it into the opening in the housing.

4. Pull the 5/8 in. (15.87 mm) gas line and grommet through the opening in the water heater housing.
5. Connect the flare fitting and press the grommet into the opening. Caulk around the grommet if the grommet was cut during the gas line installation.
6. Turn on gas and check all fittings and connections for leaks, using a soap and water solution. Correct even the slightest leak immediately.



WARNING

- It is imperative that grommet and gas line through grommet be caulked air tight. If not tightly sealed, moisture and potential harmful flue products could vent through opening and into living area of trailer.
- Do not use an open flame to check for leaks!

connected directly to a 12 VDC battery or to the filtered side of an AC/DC converter. Avoid connections to the unfiltered side of an AC/DC converter whenever possible. Use a minimum of 18-gauge wire, UL and CSA listed.



NOTICE

The 12 VDC control wiring in the Water Heater is 18-gauge stranded wire rated for 105°C (221°F). This 18-gauge wire should be sufficient for the 12 VDC control wire coming from the Water Heater to the switch and the 12 VDC power source; however, consult all local and national codes relating to your specific installation to verify.

4.5.1 Preparing the Wired Controller Installation Location



WARNING: FIRE AND/OR ELECTRICAL SHOCK HAZARD.

Failure to obey the following warnings could result in death or serious injury:

- Make sure there are no obstacles (wires, pipes, etc.) inside of the RV roof or walls at the installation locations.
- Shut off the gas supply, disconnect the 120 VAC power from RV, and disconnect the positive (+) 12 VDC terminal from supply battery before drilling or cutting into the RV.

When planning the location of the control switch(es), be sure to choose an easily accessible area for both use and service.

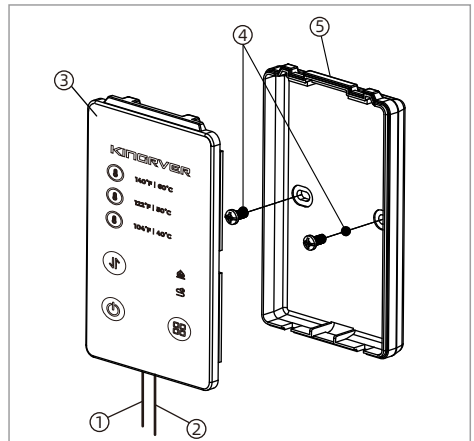

- ① White line
- ② Red line
- ③ Front Cover
- ④ 2-ST4x16
- ⑤ Back Cover

4.5 Installing The Wired Controller

Fofatti recommends that the Water Heater unit be

4.5.2 Completing the Wired Controller Installation

1. Position the wall plate with the letters and symbols oriented properly.
2. Use two screws to mount the wired controller. Tighten the screws to hold the control switch(es) firmly in place.
3. Connect the wire of the wire controller to the two blue wires of the main controller, and the wire does not distinguish between the positive pole and the negative pole of the wire controller.

4.6 Wiring the 120 VAC Power Supply



WARNING: FIRE HAZARD.

When a cord and plug connection to the power supply are used on a water heater, the power cord must be UL listed as suitable for damp locations, hard or extra hard usage. The cord must be a flexible type such as S, SO, ST, STO, SJ, SJT, SJTO, HS or HSO described in the National Electric Code ANSI/NFPA 70. The length of the external cord to the water heater, measured to the face of the attachment plug, shall be no less than 2 ft (60.96 cm) and no more than 6 ft (182.88 cm). The supply cord must be a minimum of 14 AWG. The attachment plug must be rated at 15 A. Failure to obey this warning could result in death or serious injury.



NOTICE

Do not route wires around sharp objects or where it could be smashed.



NOTICE

When using Romex® with a bare earth ground, be sure to position the ground wire so it does not contact the heating element terminals. Damage to the ground wire can occur.



NOTICE

Refer to "Wiring Diagrams" on page 17 for a comprehensive wiring schematic.

Consider the following before wiring the control switch:

- The three-prong plug must be secured to a UL approved, dedicated, minimum 15 A-rated, three prong receptacle.
- All wiring must comply with applicable electrical codes.
- Use electrical metallic tubing, flexible metal conduit, metal clad cable, or nonmetallic-sheathed cable with a grounding conductor.
- Wires must have a capacity of 1400 W or greater.
- The wiring method must conform to applicable

- sections of article 551 of National Electrical Code
- ANSI/NFPA 70.
- The receptacle must be located per all applicable codes and away from any water.

4.7 Wiring the 12 VDC Power Supply

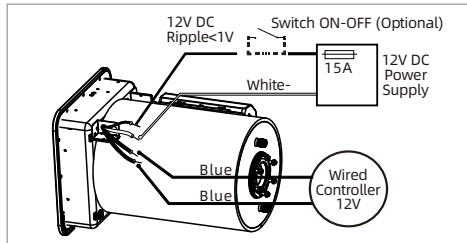

WARNING: ELECTRICAL SHOCK HAZARD

- Disconnect all power before performing any work.
- Always use a certified and proven 12V isolated power supply, that is properly grounded to the RV.
- Follow all applicable codes, regulations and instruction material when performing service work. Failure to follow instruction could result in serious injury or death.

- Wiring connected to or in proximity of the appliance must be rated for 140 °F (60 °C) minimum.
- Use only insulated terminals for all electrical connections.
- The appliance requires a power source that can adequately provide 10~17V DC to function properly.
 1. Select a distribution branch greater than 3A, preferably 15 amp, to provide nominal 12V to the appliance from the distribution panel.

NOTE: The appliance has a built in 10A fuse, serviceable from the front of the product. The appliance can be on a dedicated or shared branch circuit with the same or higher rating.

Optional: A power switch can be placed in the living quarters for convenience, but not required as a switch is located externally on the appliance. If the switch is fused, make sure it is rated for at least 3amps.
 2. Locate entry point for the wiring to service the rear of the appliance. Ensure entry point is not in the footprint space of the appliance make sure any edges are protected to prevent wire abrasion from occurring.
 3. Determine the appropriate wire gauge (AWG) for the 12V power supply length. Ensure enough wire is available to make adequate connection.
 - 16AWG max. 40 feet (12m)
 - 14AWG max. 66 feet (20m)
 4. Feed wire from power source to the entry point. Make connection to the power source.

4.8 Installing The Unit



WARNING: CARBON MONOXIDE, FIRE AND/OR EXPLOSION HAZARD.

Failure to obey the following warnings could result in death or serious injury:

- Be sure the unit is vented and sealed properly to avoid the collection of carbon monoxide inside of the RV.
- All combustion air must be supplied from outside of the RV. All combustion products must be vented to the outside of the RV.
- Do not vent the water heater with a venting system that serves another appliance.
- Do not vent the water heater to an outside enclosed porch area.
- Protect building material from flue gas exhaust.
- Install the water heater on an exterior wall with access to a door opening to the outdoors.
- Do not alter the water heater for a positive grounding system.
- Do not high-potential test (HI-POT) the water heater unless the DSI control board has been disconnected (DC HI-POT).
- Do not use a battery charger to supply power to the water heater at any time or when testing.



CAUTION

- Do not modify the water heater in any way.
- Do not lift, push, or misalign the main burner tube. Damage to the burner and the water heater can occur.



NOTICE

Install in recreation vehicles only. RVs are recreation vehicles designed for temporary living quarters for recreation, camping, or travel using their own power or towed by another vehicle.

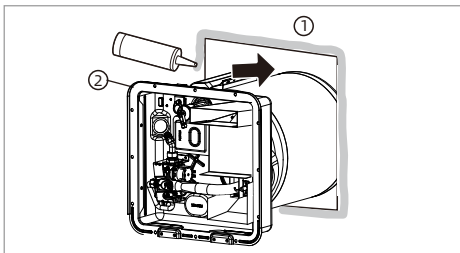

① Opening

② Flange Slots

1. Caulk thoroughly around the opening and the flange slots.



NOTICE

Butyl tape 1-1/4 in. x 1/8 in. (32 mm x 3 mm) may be substituted for caulking material.

2. Push the unit against the caulking in the cutout.

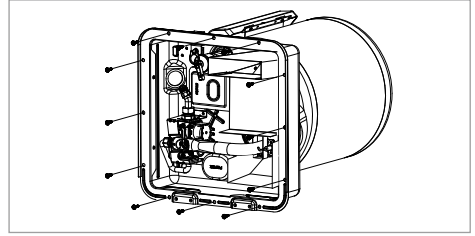

3. Secure the two top corner brackets to the water heater flange using six #8 3/4 in. round head screws or equivalent.



NOTICE

The screws are not provided with the unit.

4. Place the left hinge bracket over the bottom left corner bracket and secure them to the housing using three #8 3/4 in. round head screws or equivalent.
5. For the bottom right corner bracket, attach using only one #8 3/4 in. round head screw or equivalent in the top hole for now.
6. Secure the housing to the RV using eight #8 3/4 in. round head screws or equivalent in the holes around the flange.
7. Visually inspect all gaskets to ensure that they adhere to the pan and create an air tight seal.
8. Cut the strap on the front of the water heater and gently pull free from the brackets.



NOTICE

Do not remove the brackets

4.9 Performing Leak Testing



WARNING

FIRE AND/OR ELECTRICAL SHOCK HAZARD.

Do not use matches, candles, or other sources of control when checking for gas leaks. Failure to obey this warning could result in death or serious injury.



NOTICE

Isolate the Water Heater from the gas supply piping system before performing any pressure test equal to or greater than 0.5 PSI (34 mbar).

1. Turn on the gas and check the Water Heater and all of the connections for gas leaks using leak detection solution.
2. Fill the water heater tank with water.
3. Check the tank and all water hose connections for leaks.

5 Operation



WARNING: BURN HAZARD, FIRE, EXPLOSION, AND/OR CARBON MONOXIDE HAZARD.

Keep the water heater area clear of combustible cleaning materials, gasoline, and other flammable vapors and liquids. Failure to obey this warning could result in death or serious injury.



WARNING: CARBON MONOXIDE, FIRE AND/OR EXPLOSION HAZARD.

Failure to obey the following warnings could result in death or serious injury:

- Do **not** store or use gasoline or other flammable vapors and liquids in the vicinity of this or any other appliance.
- Should overheating occur, or the gas supply fail to shut off, turn the operating switch to the OFF position and close the gas valve to stop the gas supply.
- Use with L.P. gas only.
- Shut off gas appliances and pilot lights when refueling.
- Turn gas off at the L.P. tank when the vehicle is in motion. This disables all gas appliances and pilot lights.
- Gas appliances must never be operated while the vehicle is in motion. Unpredictable wind currents may be created which could cause flame reversal in the burner tub, which could result in fire damage. The thermal cut off fuse could also be unnecessarily activated resulting in a complete shutdown of the water heater requiring replacement of the thermal cut off.



CAUTION: FIRE HAZARD.

Do **not** smoke or have any flame near an open faucet. Failure to obey this caution could result in minor or moderate injury.



CAUTION: EXPLOSION HAZARD.

If water heater has not been used for more than two weeks, hydrogen gas may form in the water line. Under these conditions, to reduce the risk of injury, open the hot water faucet for several minutes at the kitchen sink before you use any electrical appliance connected to hot water system. If hydrogen gas is present, you will probably hear sounds like air escaping through the pipe as water begins to flow. Failure to obey this warning could result in death or serious injury.



NOTICE

It is imperative that the water heater tank be filled with water before operating the water heater. Operation of the water heater without water in the tank may result in damage to the tank and /or controls. This type of damage is not covered by the limited warranty.

5.1 Operating instructions

Users should confirm whether the water heater is installed correctly before the first use, and carefully check whether the connection is correct without leakage. After confirming all is correct, re-start the water heater.

During and after the operation of the water heater, the temperature at the exhaust outlet and the surrounding part is high. Please do not touch either with your hands to avoid burns.

Before showering or bathing, test the water temperature with your hands to avoid burns.

5.2 Wired controller operation

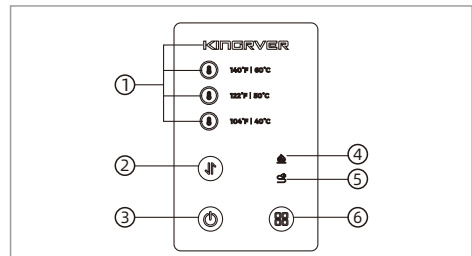

- ① Temperature display
- ② Temperature adjustment button
- ③ ON/OFF button
- ④ Gas heating display
- ⑤ Electric heating display button
- ⑥ Heating mode button

ON/OFF button:

1. switch between on and off status.
2. On/Off Indicator: When the power is turned on, the indicator will be permanently on. When the power is off, the indicator will be shut off.
3. In the case of a system failure, pressing this button clears the fault code.
4. Fault indication: When a failure occurs, the "On/Off button indicator" flashes a matching number of times to show the various problems.

Temperature adjustment button:

At each press, the preset temperature of 104 °F (40 °C), 122 °F (50 °C) and 140 °F (60 °C) can be selected and switched in cycles.

BB Heating mode button:

At each press, select gas heating mode, electric heating mode, gas and electric simultaneous heating mode cycle switching.

Ⓢ Temperature indicator:

The temperature display lights up in red when heating. The temperature display lights up in green when heated to the preset temperature.

🔊 Heating mode display:

When gas heating is selected, the gas heating indicator will be on. When electric heating is selected, the electric heating indicator will be on. When the gas and electric heating mode is selected, the gas and electric heating indicator will be on.

Power supply display:

For one second, all lights are turned on. The mode of the most recent power outage is also displayed, as are the lights for the selected temperature.

Buzzer:

1. When the heater is powered on or a proper key operation is made, the buzzer makes a "B" sound.
2. After a fault, the buzzer will sound continuously for 30 seconds and may be deactivated by hitting any key.
3. When the heater reaches the preset temperature, the buzzer will sound once and enter into heat preservation state.

5.2.1 Gas Heating Mode



WARNING: BURN HAZARD, FIRE, EXPLOSION, AND/OR CARBON MONOXIDE.

Keep the water heater area away from combustible cleaning materials, gasoline, and other flammable vapors and liquids. Failure to comply with this warning may result in death or serious injury.

When the power switch turns to the ON position, click the switch button, select the temperature that needs to be heated, and then select the gas heating mode, the gas heating indicator lights up, and the water heater starts to try to ignite. If for some reason there is no ignition, the switch indicator on the remote controller flashes twice and beeps an alarm.

5.2.2 Electric Heating Mode

When the power switch turns to the ON position, click the switch button, select the temperature that needs to be heated, and select the electric heating mode, the electric heating indicator lights up, and the relay closes and passes 120 VAC to the heating tube. If the water heater fails, the switch indicator on the wire controller flashes twice and beeps an alarm.

5.2.3 Gas and Electric Simultaneous Heating Mode

When the power switch turns to the ON position, click the switch button, select the temperature that needs to be heated, and then select the gas-electric heating mode, the gas and electric heating indicator lights up. If the gas fails to ignite, the gas mode will lock, the switch indicator flashes 3 times, and beeps the alarm because the electric heating mode is still running; If the electric heating mode is locked and the gas heating mode is operating normally, the switch indicator will flash 4 times and beep the alarm.

5.3 Thermostat Manual Reset

If the Water Heater fails to operate due to high-water temperature, a lockout condition will occur. Investigate the cause of overheating and correct the issue before resetting the Water Heater.

Investigate the cause of the overheating then perform the following to reset the Water Heater:

1. Allow water to cool.
2. Place the control switch in the OFF position and wait 30 seconds.
3. Turn the control switch to the ON position.
4. Open the door panel and press the button as shown below to reset the thermostat.

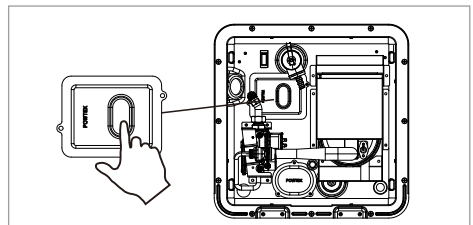

If the lockout condition persists:

1. Read the Maintenance and Care Instructions and the Electronic Control Maintenance in this manual.
2. Contact a Kingrver Service Center.

5.4 Shutting Down the Water Heater

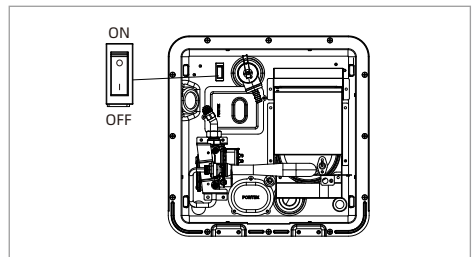

**NOTICE**

Perform these steps before performing any service on the Water Heater.

1. Place the control switch in the OFF position.
2. Turn the power switch to the OFF position.

5.5 High altitude use

For Canada: 0~4500ft above sea level; For US: 0~5000 ft above sea level. If it exceeds 5000 ft, it shall comply with the requirements of Canadian installation regulations CSA B149.1 and American installation regulations ANSI Z223.1/NFPA54, and the input rate will decrease by 4% for every 1000 ft increase in altitude.

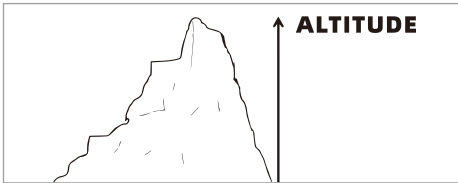

6 Maintenance And Care

**WARNING: CARBON MONOXIDE POISONING HAZARD.**

Gas flames consume oxygen, which must be replaced to assure proper combustion. Provide fresh air during testing, service, and maintenance of this appliance. Failure to obey this warning can result in death or serious injury.

**WARNING: FIRE OR EXPLOSION HAZARD.**

Failure to obey the following warnings could result in death or serious injury:

- When performing any maintenance or care, shut off the gas supply at the L.P. container before disconnecting a gas line.
- Keep the control compartment clean and free of gasoline, combustible material and any flammable liquids and vapors.

**NOTICE**

- During service of the controls, label all wires before disconnecting any wires.
- Verify proper operation after servicing.

Have the gas pressure tested periodically. The pressure should be set at 11 in. (27.94 cm) of water column with three appliances running.

Have the gas pressure tested periodically. The pressure should be set at 11 in. (27.94 cm) of water column with three appliances running.

Drain the Water Heater at regular intervals (at least one time during the year).

Drain the Water Heater before storing the RV for the winter or when the possibility of freezing exists.

Keep the vent and combustion air grill clear of any obstructions.

Periodically check the main burner flame.

6.1 Performing Preventative Maintenance

Spiders, mud wasps, and other insects can build nests in the burner tube. This will cause poor combustion, delayed control, or flame outside of the combustion tube and the burner assembly.

Listen for a change in burner sounds or look for changes in flame appearance from a hard blue flame to a soft lazy flame or one that is very yellow. These are indications of an obstruction in the burner tube or the burner assembly.

Inspect and clean the burner tube on a regular basis. Run a flexible wire brush down the burner tube to remove obstructions or clean the burner tube and the burner assembly.

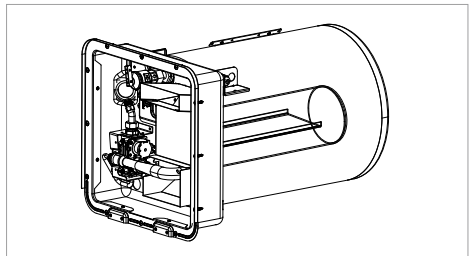

6.2 Electronic Ignition Module Cleaning

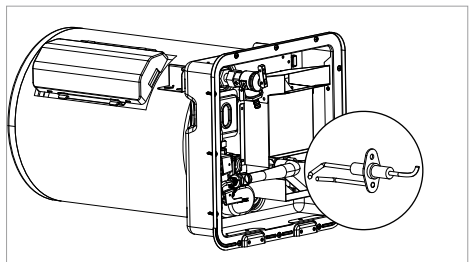

1. Inspect the main burner orifice.
2. Clean and adjust the main burner.
3. Ensure the main burner and the valve manifold are aligned with each other.
4. Inspect the electrode for cracked porcelain.
5. Ensure the electrode gap between the electrode and the ground is 0.125 in. (0.3175 cm).
6. Check for intermittent functionality of the DSI control board. If the DSI control board is experiencing intermittent functionality, remove the DSI control board and clean the terminal block with a pencil eraser.

6.3 Maintaining the Water Heater Tank



CAUTION: SCALDING HAZARD.

Turn off the water heater and allow time for the water to cool before removing the drain plug to flush the water heater tank. Failure to obey this caution could result in minor or moderate injury.

6.3.1 Winterizing the Unit



NOTICE

- To ensure the best performance of the Water Heater and to extend the life of the tank, periodically drain and flush the water heater tank.
- Drain and flush the tank before long term storage or freezing weather.

1. Turn off the main water supply (the pump, the water supply, or the water hook up source) then lift the handle on the T&P relief valve. This will allow water to flow out of the drain opening.
2. Drain the water heater tank by removing the drain plug.

After draining the tank, because of the placement of the drain plug, approximately two quarts of water will remain in the tank. This water contains most of the harmful corrosive particles. To remove these harmful corrosive particles, flush the tank with either air or water. Whether using air or water pressure, it may be applied through the inlet or outlet on the rear of the tank or the T&P relief valve. (If using the T&P relief valve, the handle must be pulled straight out). The pressure will force out the remaining water and the corrosive particles.

If you use water pressure, pump fresh water into the tank with the assistance of the on-board pump or use external water for 90 seconds to allow the fresh water to agitate the stagnant water on the bottom of the tank and force deposits through the drain opening. Continue adding water and draining until the particles have been cleared from the water remaining in the tank.

If sporadic water flow is encountered, open the T&P relief valve to allow air into the tank. Using a small gauge wire or coat hanger, poke through the drain opening to eliminate any obstructions.

3. Replace the drain plug and close the T&P relief valve.



NOTICE

The two quarts of water remaining in the tank after draining the tank will not cause damage to the tank should freezing occur.

6.3.2 Flushing the Tank

Use this procedure for general flushing of the water heater tank.

1. Turn off the main water supply (the pump or water hook up source).
2. Remove the drain plug to drain the water from the tank.



NOTICE

If the water drains sporadically or trickles out of the drain hole, open the T&P relief valve then use a small gauge wire or coat hanger to remove any obstructions from the drain hole.

With the tank drained, approximately two quarts of water remain at the bottom of the tank. This water contains most of the corrosive particles. To remove these particles, use an "RV Water Heater Flushing Tool." The wand of this flushing tool allows the water jet to clean at different angles inside of the tank. Cleaning at different angles inside of the tank will suspend and flush the corrosive particles out of the drain coupling.

3. Continue flushing the tank until the water being flushed from the drain coupling is draining as clear water.
4. Replace the drain plug.

6.3.3 Flushing to Remove Unpleasant Odor

A rotten egg odor (hydrogen sulfide) may be produced when the electro-galvanic action of the cladding material releases hydrogen from the water. If sulfur is present in the water supply, the two will combine and produce an unpleasant smell.

1. Turn off the main water supply.
2. Remove the drain plug to drain the water heater tank.
3. Reinstall the drain plug.
4. Remove the T&P relief valve.
5. Mix a solution of four parts white vinegar to two parts water.
6. With a funnel, carefully pour the solution into the tank.
7. Cycle the Water Heater with the vinegar/water solution, letting it run under normal operation four to five times.
8. Remove the drain plug and thoroughly drain all of the water from the tank.
9. Flush the Water Heater to remove any sediment. You may flush the tank with air pressure or fresh water. Pressure may be applied through either the inlet or outlet valves on the rear of the tank or through the T&P relief valve coupling located on the front of the unit. If flushing through the T&P relief valve, lift the handle and apply the air pressure.

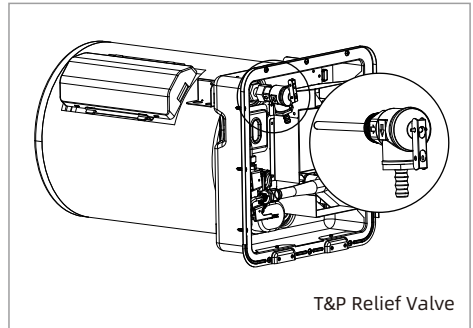

T&P Relief Valve

The T&P relief valve is not serviceable. If the T&P relief valve is found to be faulty, replace the valve.

This Water Heater is equipped with a T&P relief valve that complies with the standard for Relief Valves and Automatic Gas Shutoff Devices for Hot Water Systems, ANSI Z21.22.

If a discharge line is used, do not use a reducing coupling or other restriction smaller than the outlet of the T&P relief valve. Allow both the valve and the line to completely drain.

A T&P relief valve dripping while the Water Heater is running does not mean it is defective. During normal expansion of water, as it is heated in the closed water system of an RV, may cause the T&P relief valve to drip. The Kingrver water heater tank is designed with an internal air gap at the top of the tank to reduce the possibility of dripping. Over time, the expanding water will absorb this air and it must be restored. Due to variations in water quality, the T&P relief valve may have a shorter life and may need replacement within the Water Heater warranty period. If corrosion is detected, it will not be covered under warranty.



WARNING: EXPLOSION OR SCALDING HAZARD.

Failure to obey the following warnings could result in death or serious injury.

- Do not tamper with the T&P relief valve.
- Do not place a valve, plug or reducing coupling on the outer part of the T&P relief valve.



NOTICE

- The T&P relief valve is a safety component and must **not** be removed for any reason other than replacement.
- Tampering with the T&P relief valve will void the warranty.

Replacement T&P Relief Valve Parts

- Do not install anything less than a combination T&P relief valve certified by a nationally recognized testing laboratory that maintains periodic inspection of product of listed equipment or materials, as meeting requirements for Relief Valves and Automatic Gas Shutoff Devices for Hot Water Supply Systems, ANSI Z21.22. The Valve must have a maximum set pressure not to exceed 150 PSI (1034.21 kPa).
- Install the valve into the provided opening marked for this purpose on the Water Heater.
- Installation must conform with local codes or in the absence of local codes, American National Standard for Recreational Vehicles, ANSI A119.2/NFPA 501C.
- For an external electrical source, ground this unit in accordance with National Electrical Code ANSI/NFPA70.

6.5 Using After-Market Water Heating Element Devices



WARNING: EXPLOSION AND OR BURN INJURY.

Failure to obey the following warnings could result in death or serious injury:

- Do not use after-market heating elements. After market heating elements can lack critical safety controls.
- Do not use bug screens, anode rods or other non-approved devices with this water heater.
- The use of after-market heating elements can lead to uncontrolled water tank heating and tank explosion.



NOTICE

- The use of any after-market heating element devices may result in damage to components or the water heater.
- Any alteration, such as the addition of an after-market heating element device, will void the warranty.

7 Troubleshooting

7.1 Fault description and troubleshooting

Failure name	Problem Description
Water probe failure	When the water probe is open or short-circuited, all of the solenoid valves and heating tubes are turned off. Additionally, the indicator light flashes for one continuous cycle, and a blaring alarm lets you know that there is a problem.
Ignition failure, accidental flame failure, false flame failure	A failure has been detected when the light flashes twice in rapid succession, the buzzer alert goes off, and the gas component ceases to function. During operation, there was an unexpected failure with the flame, the indicator light flashed twice in rapid succession, the buzzer alert indicated that there was a problem, and the gas component stopped operating. When a flame signal is detected prior to beginning, the indicator light will flash twice in rapid succession, the blaring alarm will indicate that there is a problem, and the gas component will stop functioning.
Solenoid valve failure / thermostat protection failure	Before ignition, a short circuit or open circuit was detected in a valve; during operation, an open circuit was identified in a valve; all solenoid valves were closed; the indicator light flashed three times; and a buzzer warning indicated that a problem had occurred. The gas portion has stopped functioning.
Heating tube failure	A failure is indicated by the light flashing four times in rapid succession and an audible beeping sound when there is no heating tubing present. The electric heating portion loses its ability to function.
Electronic anode failure	When a short circuit is detected in the electronic anode, the indicator light will flash six times in rapid succession, the beeping alarm will indicate that there is a problem, and the combustion and electric heating parts of the system will stop working. The system will not work again until the power is removed and the electronic anode is returned to its normal state.

■ Failure alarm explanation and reset method

In the event that any of above error code is displayed, please ensure that the water and gas supplies are normal, press the on/off switch on wired controller to turn off the power or restart the heater. If performing these steps does not bring the heater into normal operation, please get in touch with the after-sales service people for help.

7.2 Non-defect when the following conditions occur:

Phenomenon	Reason and handling method
White smoke at exhaust	When the outdoor temperature is too low, the exhausted smoke encounters outdoor cold air and condenses into a white mist.
Failure to provide hot water during winter	The water temperature is too low, the water flow exceeds the heating capacity of the water heater. Please adjust the amount of water appropriately.
After closing the hot water valve, the fan did not stop immediately	The function of delaying the shutdown of the fan is to completely discharge the exhaust gas of the water heater to ensure the safety of the user.
After opening, hot water does not come immediately	On the one hand, the time lag between the hot water valve and machine body may be the reason. On the other hand, the existed cold water within pipeline takes time to be showered out, the longer the pipeline, the longer time it takes.
After the machine is powered on, the remote controller does not respond	Open the door of the water heater door and make sure the switch inside the door is open and the fuse is intact. If the fuse blows, replace with fuse of the same size. (Fuse:10A 125V)

8 Wiring Diagrams

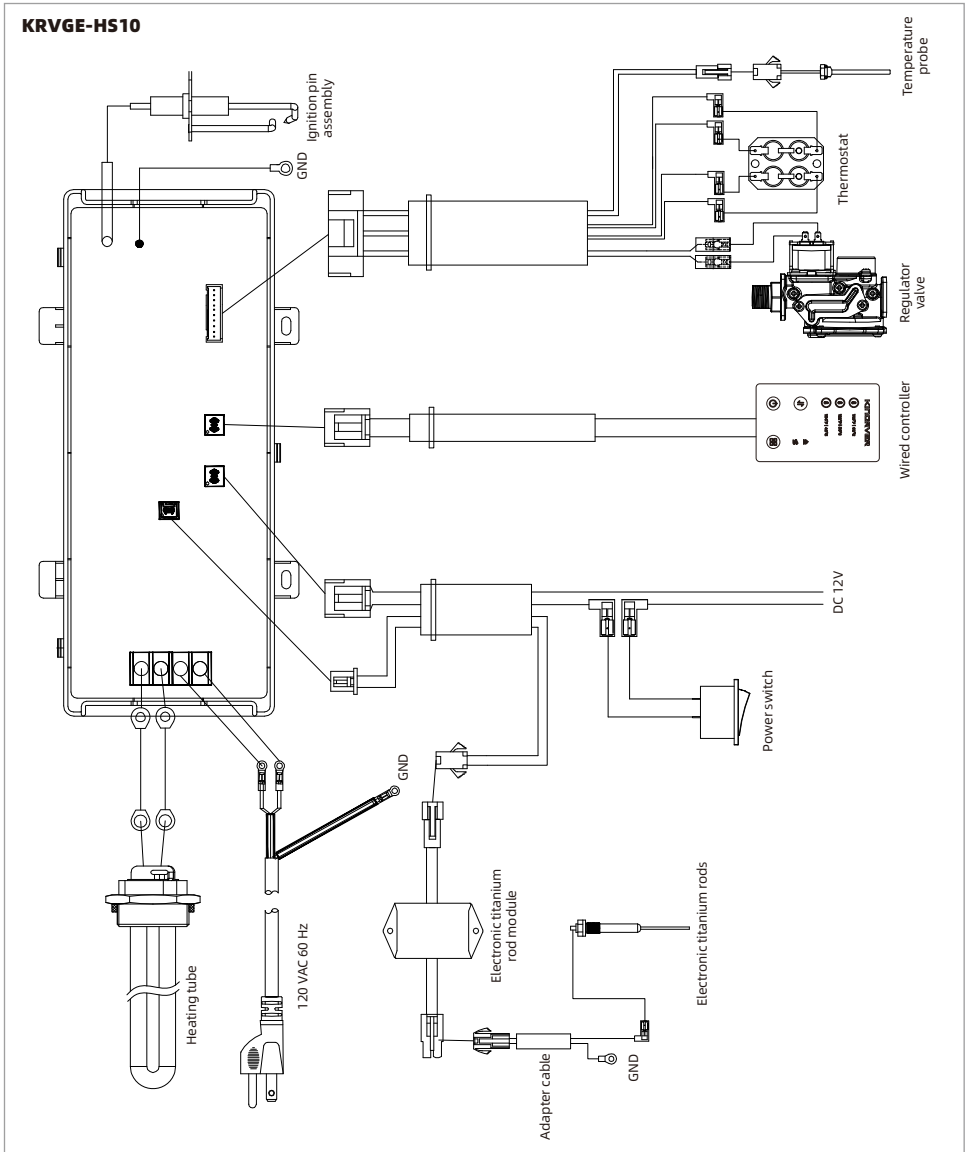

NOTICE



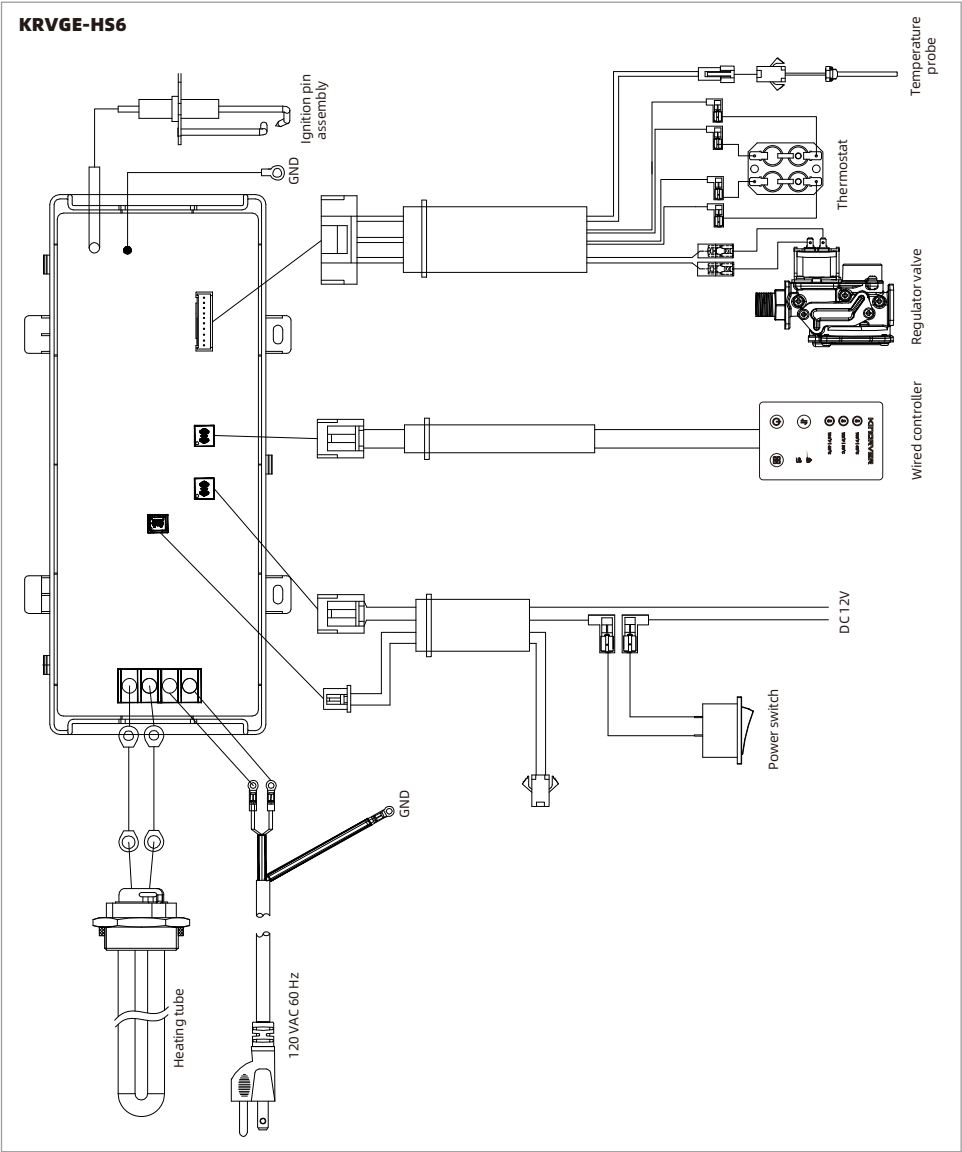



Label all wires prior to disconnecting when servicing controls. Wiring errors can cause improper and dangerous operation. Verify proper operation after servicing.

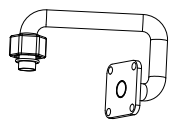
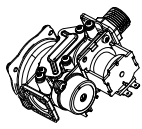
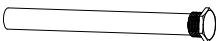
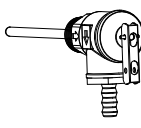

NOTICE

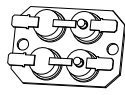
Label all wires prior to disconnecting when servicing controls. Wiring errors can cause improper and dangerous operation. Verify proper operation after servicing.

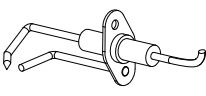
9 Replacement parts: components

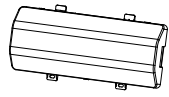
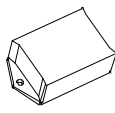
Parts	Photo	Parts	Photo
Lock		Intake connecting pipe	
Gas control valve		magnesium anode rods (KRVGE-HS6)	
Temperature and Pressure Relief Valve		Wired Controller	
Thermostat		Electronic titanium rods (KRVGE-HS10)	
Ignition pin assembly		Water Outlet temperature probe	
Heating pipe		Burner controller	
Electronic titanium rod module			

10 Disposal



Disposal

Place the packaging material in the appropriate recycling waste bins, whenever possible. Consult a local recycling center or specialist dealer for details about how to dispose of the product in accordance with all applicable national and local regulations.

LIMITED ONE-YEAR WARRANTY

If you have questions, or to obtain a copy of the limited warranty free of charge, contact:

Kingrver corporation

Tel: 877-216-1818

KINGRVER

Tel: 877-216-1818
1.05.06.4005