



Meat Mincer

Instruction Manual



Model: HM-12/HM-22/HM-22A

Please read this instruction manual carefully before operating this equipment

Safety Tips



Read this instruction manual before using and keep them available at all times!

INTRODUCTION

- This instruction manual gives the customer all the necessary information about the appliance and the manufacturing standards applied, as well as all instructions for use and maintenance so that the appliance can be used correctly maintaining its efficiency in time.
- This instruction manual is for the end user and for service personnel

INDEX

1	INFORMATION ABOUT THE APPLIANCE	3-4
1.1	GENERAL WARNINGS.....	3
1.2	SAFETY FEATURES INSTALLED.....	3
1.3	APPLIANCE DESCRIPTION.....	3
1.3.1	GENERAL DESCRIPTION.....	3
1.3.2	CONSTRUCTIVE CHARACTERISTICS.....	4
1.3.3	APPLIANCE ELEMENTS.....	4
2	TECHNICAL DATA	4
2.1	TECHNICAL CHARACTERISTICS.....	4
3	CONSIGNING THE APPLIANCE.....	5
3.1	CHECKING PACKAGING UPON CONSIGNMENT.....	5
3.2	DISPOSING OF PACKAGING.....	5
4	INSTALLING THE APPLIANCE.....	5
4.1	APPLIANCE LOCATION.....	5
4.3	WIRING DIAGRAMS HM-12/HM-22/HM-22A/HM-22B.....	5
4.4	FUNCTIONAL CHECK.....	5-6
5	USING THE APPLIANCE.....	7-8
5.1	CONTROLS	7
5.2	SETTING UP THE HM-12/HM-22/HM-22A/HM-22B FOR USE.....	7
5.3	FILLING THE MINCER(see fig 5)	7-8
6	REGULAR CLEANING.....	8-9
6.1	GENERALITIES.....	8
6.2	PROCEDURE TO FOLLOW FOR CLEANING THE APPLIANCE.....	8-9
7	MAINTENANCE	10
7.1	GENERALITIES.....	10
7.2	FOOT SUPPORTS.....	10
7.3	POWER SUPPLY CABLE.....	10
7.4	PUSH BUTTON LABEL.....	10
7.5	DISK AND BLADE.....	10
8	SCRAPPING.....	10
8.1	OUT OF SERVICE.....	10
8.2	SCRAPPING.....	10
9	Waste disposal	11
10	Warranty.....	11

1 INFORMATION ABOUT THE APPLIANCE

1.1 GENERAL WARNINGS

- The appliance must only be used by personnel who has carefully studied this manual and understood all the safety standards described herein.
- If there should be a turnover in personnel, it is necessary that this manual is carefully studied before using the appliance.
- Although safety devices are installed on the appliance, avoid touching the moving parts with your hands and avoid touching the appliance with wet hands.
- Before cleaning or servicing the appliance, disconnect the electricity power supply.
- When cleaning or servicing the HM-12/HM-22/HM-22A /HM-22B(safety protections removed) take into consideration all possible hazards-Residual Risks.
- When cleaning or servicing the appliance always concentrate on what you are doing and avoid any possible distractions.
- **WARNING** - The machine should be repaired by manufacturer or agent if the machine faults.
- If the supply cord is damaged, it must be replaced by the manufacturer, its service agent or similarly qualified persons in order to avoid a hazard.
- Check the electricity power cable on a regular basis (to avoid electrical hazards and twists in the cable always completely unwind it);a worn or damaged cable causes a dangerous electrical hazard;avoid pressing the cable with weights or leaving it on hearted or sharp cutting Surfaces and avoid pulling the cable to remove the plug from the socket.
- If the HM-12/HM-22/HM-22A/HM-22B has a presumed malfunction or does not work correctly, do not use it or repair it. Contact the “Service Centre”.
- This appliance is designed for only mincing meat in the mincer.Do not use this appliance for frozen food or non-food products and do not insert any metallic objects into the mincer .
- Do not mince without using the pestle

The manufacturer cannot be held responsible for the following situations:

- If the appliance or safety devices are tampered with by unauthorized personnel;
- If non-original spare parts are used;
- If the instructions given in this manual are not carefully followed or respected;
- If unsuitable cleaning products (flammable, corrosive or toxic) are used to clean the appliance.

1.2 SAFETY FEATURES INSTALLED

Safety features against electrical hazards conform to standards IEC/EN60335-2-64, whereas mechanical safety features conform to EN/IEC60335-2-64 .

The HM-12/HM-22/HM-22A /HM-22B is fitted out with:

Relay in the command circuit for restarting the appliance if there if there is a power cut;

The HM-12/HM-22/HM-22A/HM-22B is fitted out with electrical and mechanical safety protections that conform to the standards in force .These protections are for when the appliance is working and when it is being cleaned or serviced .However ,there are RESIDUAL RISKS that cannot be completely eliminated and are indicated by the wording CAUTION in this manual. These risks refer to the risk of being cut or injured when handling the blade on the HM-12/HM-22/HM-22A/HM-22B while cleaning.

1.3 APPLIANCE DESCRIPTION

1.3.1 GENERAL DESCRIPTION

- We have designed and manufactured the HM-12/HM-22/HM-22A/HM-22B guaranteeing;

- The maximum of safety when using, cleaning and servicing;
- The maximum of hygiene thanks to a meticulous selection of the materials that come in contact with the food product, and thanks to the elimination of any sharp and rough edges that comes in contact with the product, cleaning is easy and thorough;
- The appliance can be easily stripped
- Robust and stable components and structure
- Maximum reduced noise level thanks to the geared transmission and oil bath
- Easy to handle

1.3.2 CONSTRUCTURE CHARACTERISTICS

The HM-12/HM-22/HM-22A /HM-22Bis made from stainless and aluminum ally for food appliances. These metals are ideal regarding hygiene, they are also acid and salt resistant are also rust proof.

1.3.3 APPLIANCE COMPONENTS

FIG 1-General view of the HM-12/HM-22/HM-22A/HM-22B



- | | | | |
|-------------------------------|-----------------------|-----------------------------|------------------|
| 1-controls | 2-base | 3-knob | 13-brace |
| 4-lock nut | 5-mincer block | 6-face cover | 14-pestle |
| 7-food tray | 8-power cable | 9-stop button switch | |
| 10-start button switch | 11-body | 12-heel cover | |

2 TECHNICAL DATA

FIG-2 TECHNICAL CHARACTERISTICS

Model	HM-12	HM-22	HM-22A	HM-22B
Voltage	220-240V/50Hz	220-240V/50Hz	220-240V/50Hz	220-240V/50Hz
Power	850W	1100W	1100W	1100W
Holes in disk	5mm/8mm	8mm/5mm	10mm/6mm	10mm/6mm
Production: Max.	120kg/h	220 kg/h	220 kg/h	220 kg/h
Weight	24kg	25.5 kg	26.5 kg	25.5 kg
Measurement	60.2*45.4 * 26.2cm	60.2*45.4 * 26.2cm	60.2*45.4*26.2c m	60.2*45.4*26.2cm

CAUTION: the appliance is designed for the electrical specifications given on the plate applied to the rear of the appliance; before connecting to the electricity power supply refer to chapter 4.2 connecting to the electricity supply.

3 CONSIGNING THE APPLIANCE

3.1 CHECKING PACKAGING UPON CONSIGNMENT

When the goods are received proceed with opening the packaging if there are no signs of damage. if when the goods are delivered there are signs of damage to the packaging, such as agent or courier, and within three days from the date indicated on the documents draw up a detailed list and report of all damage to the goods. **Do not turn the packed goods upside down!** When transporting the package make sure its four main points are firmly secured (maintain the goods parallel to the ground).

3.2 DISPOSING OF PACKAGING

The various items used for packaging (cardboard, pallets, plastic straps, polyurethane foam) are normal urban waste products and can be disposed of without difficulty.

If the appliance is destined to countries where are specific standards regarding waste, dispose of packaging respecting the standards and laws in force.

4 INSTALLING THE APPLIANCE

4.1 APPLIANCE LOCATION

4.1.1 The work surface where the HM-12/HM-22/HM-22A/HM-22B will be located must be suitable for the size of the appliance, please refer to the measurements given in FIG 2. The work surface must be level and dry and at a height of 80 cm from the ground with a temperature between 5°C and 35°C.

4.1.2 The power cord connected with the appliance must be reliable grounding.

4.2 WIRING DIAGRAMS HM-12/HM-22/HM-22A/HM-22B

FIG 3-Illustration

power switch overload protection

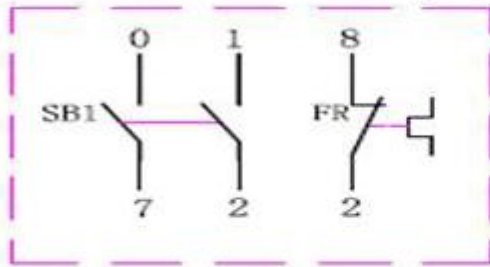

change-over switch

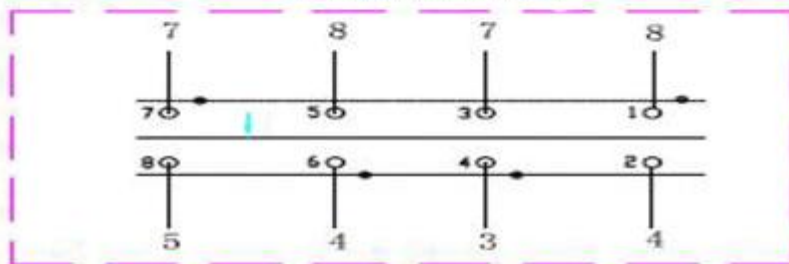

motor

capacitor centrifugal switch

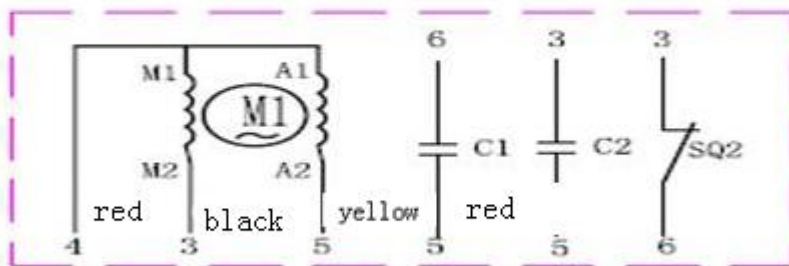

public port forward invert

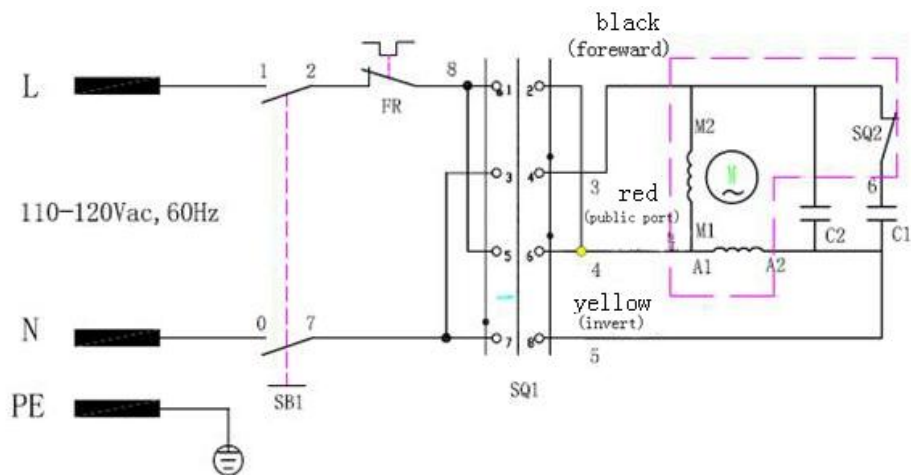

PS:1. US VOLTAGE:110V-120V, 60HZ

2. FORWARD:1-2,7-8 OF SQ1 IS CONNECTED. INVERT:3-4,5-6 IS CONNECTED

3. ONLY CONNECT FORWARD, CONCEL SQ1, CONNECT 7-(4)RED WIRE AND 8-(3) BLACK WIRE

SQ1: CHANGE-OVER SWITCH

C2:RUNNING CAPACITOR

M:MOTOR

SQ2:CENTIRGIAL SWITCH

SB1: POWER SWITCH

FR:OVERLOAD PROTECTION

C1: START CAPACITOR

4.3 FUNCTIONAL CHECK

To check the appliance works correctly proceed as follows:

- Turn to the place of “on” and check that the screw feeder rotates anti-clockwise to the outlet opening of the HM-12/HM-22/HM-22A/HM-22B;
- Turn to “off”, The appliance stop work;
- If the appliance automatically stops. Press the reverse button “turn over” check the screw feeder changes direction and starts turning clockwise.

5 USING THE APPLIANCE

5.1 CONTROLS

FIG 4-Controls

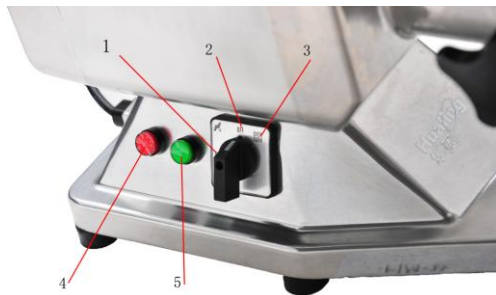

1-Start button “on”

2-Stop button “off”

3-Reverse button “turn over”

4-stop button (red)

5-start button (green)

5.2 SETTING UP THE HM-12/HM-22/HM-22A /HM-22B FOR USE

N.B before using the appliance makes sure all the components that can be removed are secured in position (see fig 6)

- Mount the mincer outlet and block it into position using the handle located on the side of the union;
- Mount the screw feeder, blade and disk, and then screw on the lock nut.

5.3 FILLING THE MINCER(see fig5)

When using the mincer it is important that you stand in the correct position. **Do not position yourself so that any part of your body comes In direct contact with the mincer when working.**

FIG 5-fitting the mincer

N.B The mincer must be filled when working. The procedure to follow is:

1. Place the food in the tray;
2. Start the mincer using the start button.
3. Raise the pestle; feed the meat into the tube; Without forcing use the pestle to push the meat into the opening.



4. If the meat suitably cut beforehand there should be no problems with the screw feeder, however, if there are problems tighten the lock nut until the meat is cut to desired size.
5. So both the disk and blade last longer and to maintain their sharpness in time:
 - When all the meat has been minced turn off the appliance;
 - Blade and disk must always be coupled.
6. Do not tighten the lock nut excessively;
7. Press the stop button when you have finished using the appliance, then strip the appliance and thoroughly clean both the opening and all other components.

6 REGULAR CLEANING

6.1 GENERALITIES

- The appliance clean must be cleaned at least once a day or if necessary more than once.
- Scrupulously clean all the various components of the HM-12/HM-22/HM-22A /HM-22B whether they come in direct contact with the food product or not.
- Never clean the HM-12/HM-22/HM-22A/HM-22B with a pressurized water-jet, industrial cleaners, and brushes or any other type of cleaning utensil that could damage the surface of the appliance.
- Before cleaning you must **remove the electricity supply plug isolating the appliance from the main power circuit.**

6.2 PROCEDURE TO FOLLOW FOR CLEANING THE APPLIANCE(see fig 6)

- remove the pestle and food tray;
- unscrew the lock nut and remove the disk:, blade screw feeder, unscrew in the direction indicated by the arrow.
- unscrew the knob and remove the mincer, always in the direction indicated by the arrow.

Now all the components can be washed(see fig 7)using warm water (50 °C) and a neutral detergent.

To clean the main structure use a damp cloth remember to frequently rinse

The grater roller mounted on the HM-12/HM-22/HM-22A/HM-22B should be brushed cleaned. Carefully clean the punched holes. Make sure all the components are completely dry before remounting them.

N.B. to remount the HM-12/HM-22/HM-22A /HM-22B follows the above diagrams:

- 1) Mount the mincer block and block it in position using the knob; the pin on the knob must be inserted into the opening;
- 2) Insert the screw feeders into the mincer block make sure it is positioned correctly;
- 3) Mount the blade onto the square pin on the screw feeder and then mount the disk maintaining the original coupling configuration;
- 4) Once all the components have been mounted secure by screwing the lock nut in place.

FIG 6-Removing components

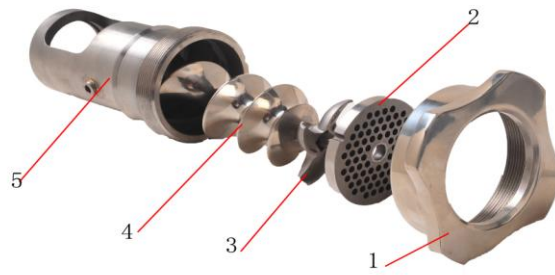

1-knob nut 2-disk 3-blade 4-screw feeder 5-mincer block

FIG 7-Diagram of HM-12/HM-22/HM-22A /HM-22B stripped for cleaning



7 MAINTENANCE

7.1 GENERALITIES

Before servicing the appliance you must disconnect the electricity supply plug isolating the appliance from the main power source.

7.2 FOOT SUPPORTS

In time the foot supports can deteriorate causing instability. If this is the case replaces them.

7.3 POWER SUPPLY CABLE

Periodically check wear in the power cable and if necessary contact the “SERVICE CENTRE” for a replacement.

7.4 PUSH BUTTON LABEL

In time the label on the could become marked or even damaged. If this should happen contact the “SERVICE CENTRE” for a replacement.

7.5 DISK AND BLADE

Both the blade and disk can deteriorate in time. If this should happen contact the “SERVICE CENTRE” for original replacements.

8 SCRAPPING

8.1 OUT OF SERVICE

If the appliance for some reason is to be put out of service, make sure it can no longer be used: disconnect and remove all electrical connections.

8.2 SCRAPPING

Once the appliance is out of service it can be scrapped. Contact a specialized company to scrap it conforming to the materials used for manufacturing the various components (**refer to chap 1 Para 3.2**)

9.Waste disposal

Discarding old devices

At the end of its service life the discarded device has to be disposed in accordance with the national regulations. It is advisable to contact a company which is specialized in waste disposal, or just contact the local disposal service in your community.

WARNING!

To exclude any abuse and the dangers involved make the waste device unfit for use before disposal. For that purpose disconnect device from mains supply and remove mains connection cable from the device.

CAUTION!

For the disposal of the device please consider and act according to the national and local rules and regulations.

10.Warranty

iMetto warrants to the original purchaser of every new product, under normal and proper use and maintenance service as specified by iMetto and upon proper installation and start-up in accordance with the instruction packet supplied with each unit. iMetto's obligation under this warranty is limited to a period of one (1) year from the date of original installation.

WARRANTY CLAIMS

All claims for parts must be made directly through iMetto. All claims should include:

Personal Details:

Your name:

Your company:

Address:

Email:

Phone:

Products Details:

Model number:

Serial number of the product:

Date of purchase:

Proof of purchase :

Pertinent information supporting the existence of the alleged defect.(Such as picture etc.)

Please send the above information to services@imettos.co.uk

Our warranty departments will according to the actual situation and reply you within 24hours.



iMettoS Limited

www.imettos.co.uk