

拖輪系列產品 PULLER ATTACHMENT



提昇品質與產量必備利器

Necessary Attachment to Improve Efficiency and Upgrade the Quality

PS 小輪、單針、雙針車用(標準型) FOR SINGLE OR TWIN NEEDLE(REGULAR) SMALL ROLLER

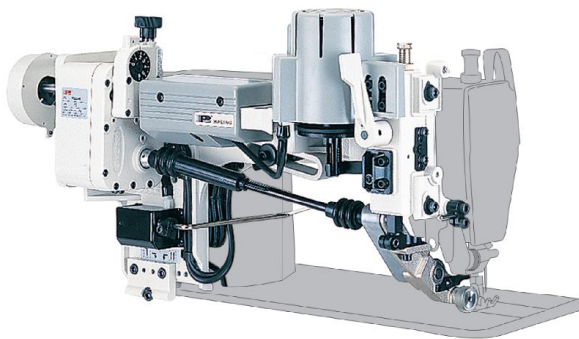

- 拖輪不用時可以提升
- Disengage roller if not needed

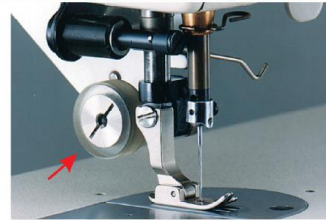

- 獨特設計，拖輪與車針距離超近，適合薄物，短距離即彎弧縫製。
- Extremely close pulling, facilitates curve and short sewing on thin materials.

PL 單針、雙針車用(標準型) FOR SINGLE OR TWIN NEEDLE(REGULAR)

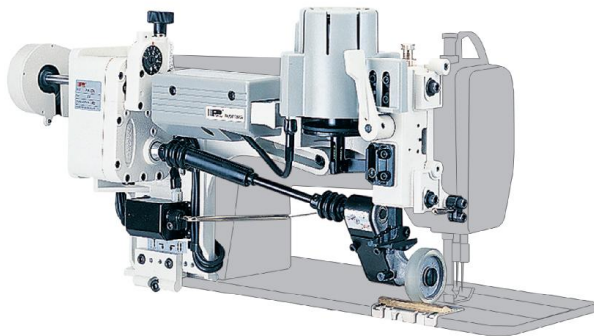

- 寬廣的操作空間
- With Large Space for Operation

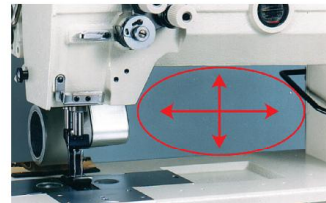

- 具多種選擇性拖輪，能適應不同質料之車縫。
- With various optional rollers for different kinds of materials.

PL-S1 飾縫車用 FOR FLAT BED COVERSTITCH

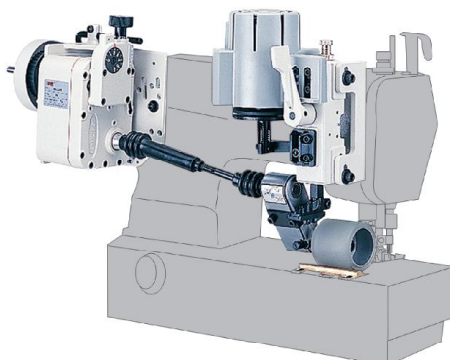

PL-S2 筒型飾縫車用 FOR CYLINDER BED COVERSTITCH

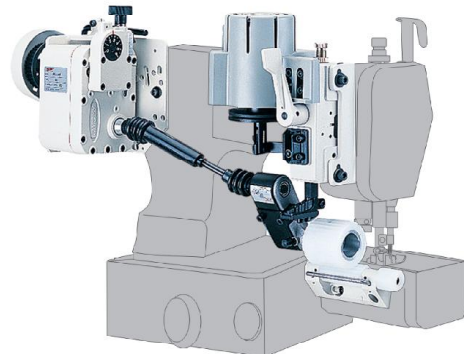

※請參照第10、11頁產品說明
※PLEASE REFER TO PRODUCT SPEC. PER P. 10 & P. 11

拖輪系列產品

PULLER ATTACHMENT

PT 單針、雙針車用·上下輪驅動(標準型)
FOR SINGLE OR TWIN NEEDLE WITH UPPER AND LOWER ROLLERS(REGULAR)

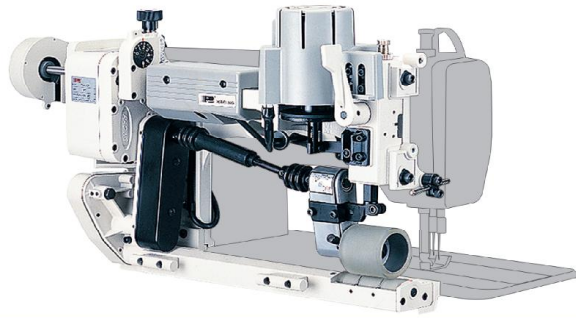

PT-L 長臂型·接受訂貨生產
FOR LONG ARM, AVAILABLE FOR CUSTOM-MADE

訂貨時告知拉布輪提昇高度及操作空間(參照P10)
Please advise the roller lifting height and operation space (please refer to P10).

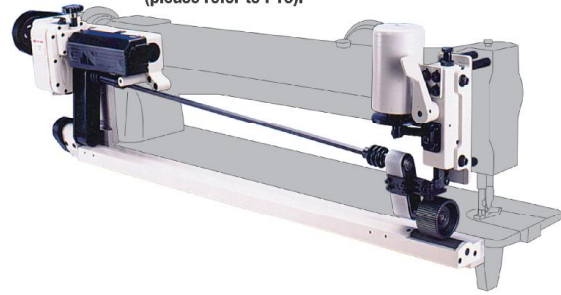

腕型車系列 FOR FEED-OFF-THE-ARM

PF 一般布料用·上輪驅動
For General Fabric, Top Driven Roller

PF-H 厚物用·上輪驅動
For Heavy Duty, Top Driven Roller

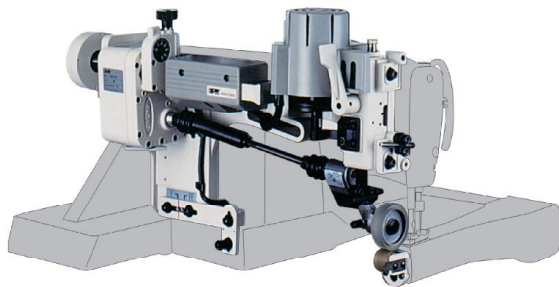

PF-HB/ECV/AF 

厚物, 極厚物用皮帶式拖輪(附厚物專用 1/8" x 1/8" 針距組)
Belt type puller for Extra Heavy Duty (with gauge set 1/8" x 1/8" for heavy duty)

PF-RB/ECV/AF 

一般布料用皮帶式拖輪
BELT PULLER FOR REGULAR FABRIC

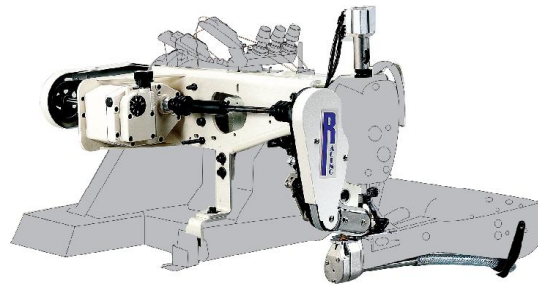

PF-UB/EFV/AF 

厚物, 極厚物用皮帶式拖輪
(針距組: 9/64"x9/64"或1/8"x1/8"擇一選用)
Belt Type Puller for Extra Heavy Duty
(Gauge Set: 9/64" x 9/64" or 1/8" x 1/8" Alternative)

適用機型: U.S. 35800
Adaptable Machine Model: JUKI MS3580
PEGASUS FV2
YAMATO DT-30
KANSAI SX6803

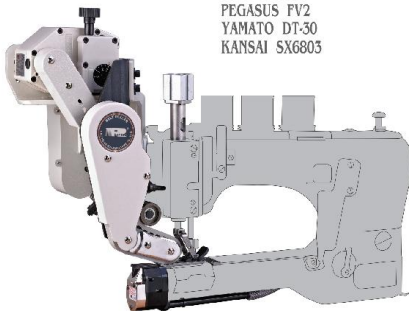

PF-FB/EFV 

四針六線用皮帶式拖輪
Belt Type Puller for Flat-Seamer

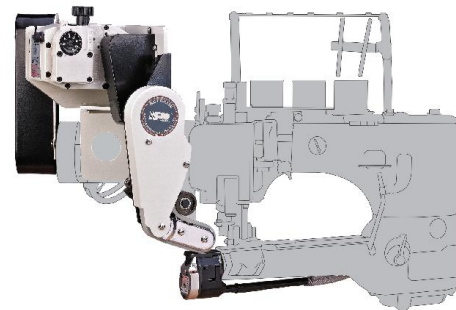

配件說明(選擇配件) Description of accessory (Optional parts)

ECV, EFV 電動式自動切線裝置
Electronic chain cutter

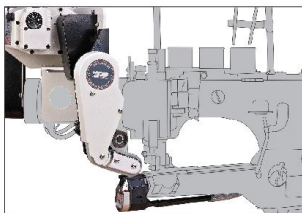

註: 本裝置可單獨購買
Remark: This device can be ordered individually.

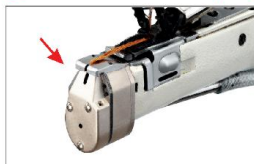

AF 氣動式壓腳提升裝置
Pneumatic presser foot

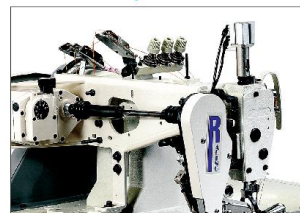

※請參照第10、11頁產品說明
※ PLEASE REFER TO PRODUCT SPEC. PER P.10 & P.11

 需空壓設備
Air compressor required

拖輪系列產品 PULLER ATTACHMENT

PY 單針、雙針車用 · 上下輪驅動
FOR SINGLE OR TWIN NEEDLE MACHINES.
PULLER WITH UPPER AND LOWER ROLLERS

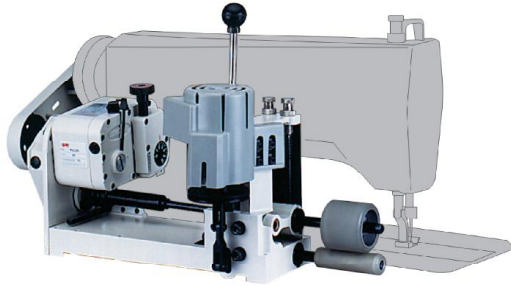

PY-SP 前拉式(義大利麵專用)
FRONT PULLER
(FOR SPAGHETTI SEWING)

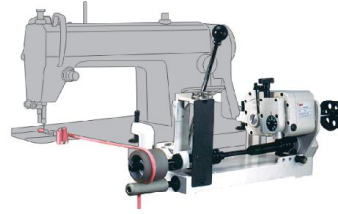

PY-C 飾縫車用
FOR COVERSTITCH

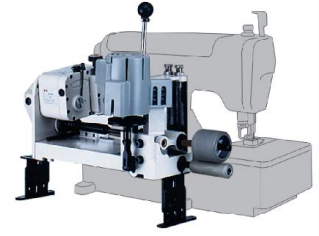

PK 包縫車用 · 上下輪驅動
FOR OVERLOOK MACHINES. PULLER WITH UPPER AND LOWER ROLLERS

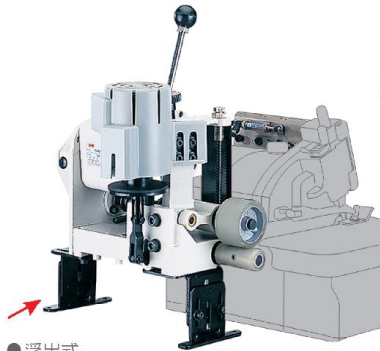

● 浮出式
● Floating type

● 適用於薄到極厚物直線縫製。
● Suitable for thin to extremely thick materials in straight sewing.



● 下沉式
● Submerged type

PK-SP 前拉式(義大利麵專用)
FRONT PULLER (FOR SPAGHETTI SEWING)

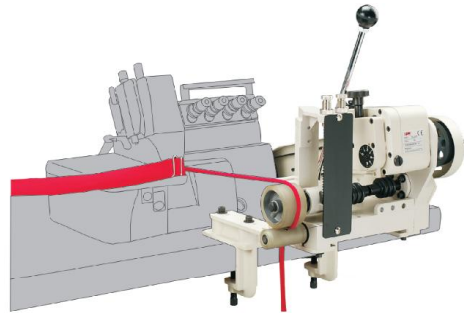

PG 包縫車用 · 小輪(薄物用)
FOR OVERLOCK MACHINES. PULLER WITH A REAR DRIVEN BELT

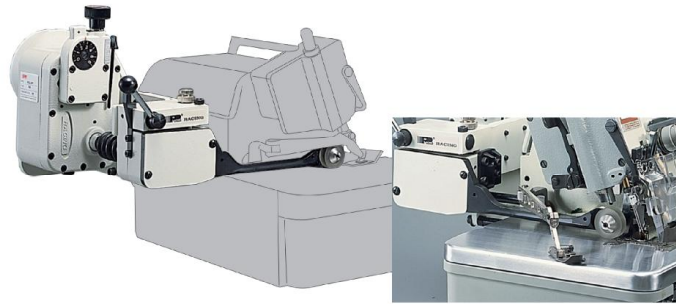

【本拖輪不能裝在附有水平或垂直式自動切線裝置的包縫車上
This puller is unable to install onto overlock machine with either vertical or horizontal automatic thread-chain cutter.】

PG 系列所需要的基本空間
Space Limitation For PG Series

● 適用機型：
● Available Models : Example :
JUKI MO 3000,6000
PEGASUS EX,MX,M
BROTHER N,V
YAMATO AZ 8000,6000
SIRUBA 757H,K

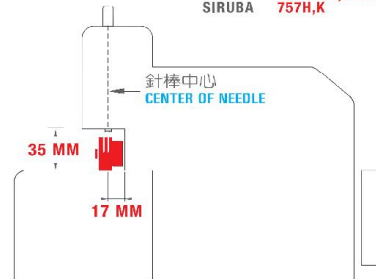

PR 包縫車用 · 皮帶後送(薄物用)
FOR OVERLOCK MACHINES. PULLER WITH A REAR DRIVEN BELT

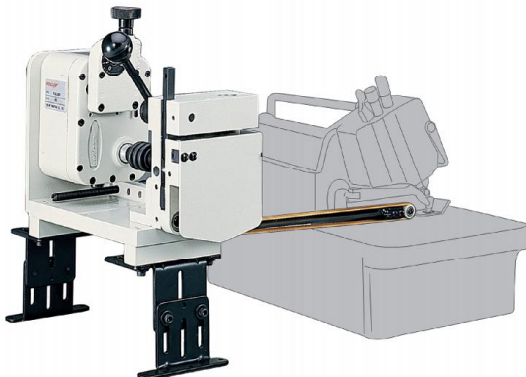

● 不受空間限制，各種廠牌機型均可安裝。
● Suitable for every machine without space limitation.

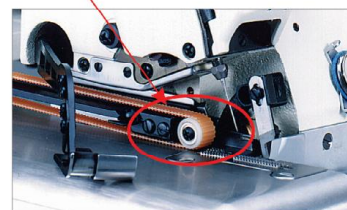

● 獨特設計，皮帶與車針距離超近。
● 適用於柔軟光滑、易皺之薄物。
● Close proximity of the rear drive belt and the needle improves sewing performance.
● Suitable for silky and easy to pucker thin materials.

拖輪系列產品

PULLER ATTACHMENT

PO 三、四線包縫車用·上皮带送
FOR 3 & 4 THREAD OVERLOCK MACHINES.
PULLER WITH TOP DRIVEN BELTDRIVE BELT

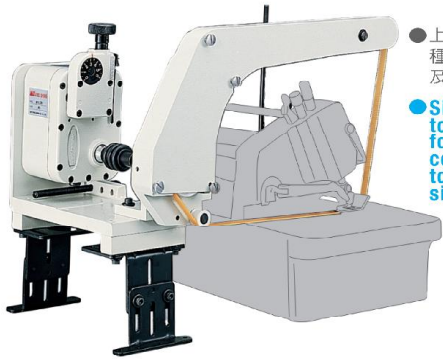

● 上皮带驱动，適用於各種編織毛領、多層艱澀及易滑之布料。

● Simple installation with top drive belt. Suitable for different knitting collars, multi-layer tough abrasive and silky materials.

PO-F 三、四線包縫車用(有領T恤專用)附氣動式包邊器
FOR 3 & 4 THREAD OVERLOCK MACHINES (FOR SEWING THE COLLARS OF A KNIT SHIRT) WITH AN AIR TYPE FOLDER.

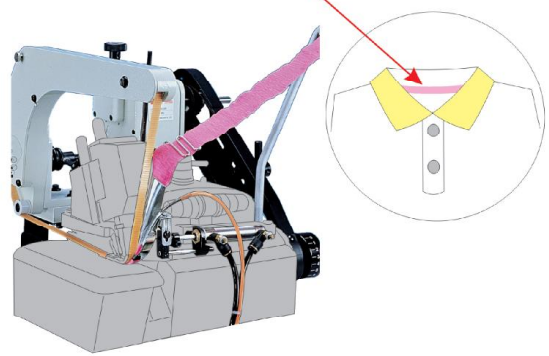

PW 手臂可動型盲縫車用(適用於潛水衣布料)
FOR BLINDSTITCH MACHINE WITH MOVEABLE ARM
(Suitable for diving-suit material)

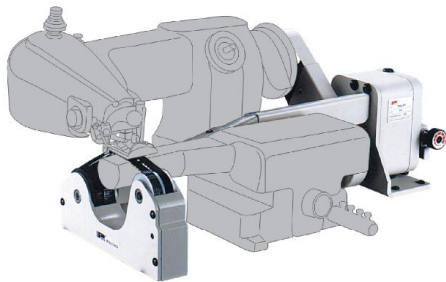

PW-L 手臂可動長臂型盲縫車用(適用於潛水衣布料)
FOR LONG ARM BLINDSTITCH MACHINE WITH MOVEABLE ARM
(Suitable for diving-suit material)

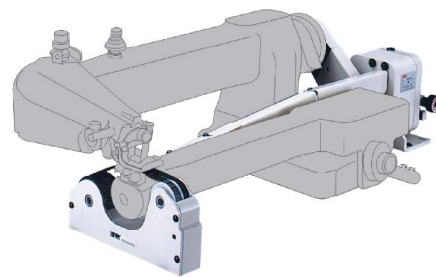

特殊機型·訂貨生產

Custom-made Order

範例
EXAMPLE

JUKI DSC-246

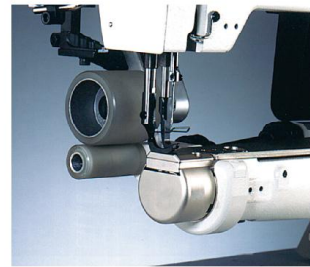
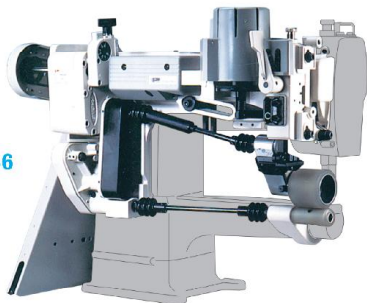

範例
EXAMPLE

● 皮帶式上送拖輪
 ● Top Belt Feed puller

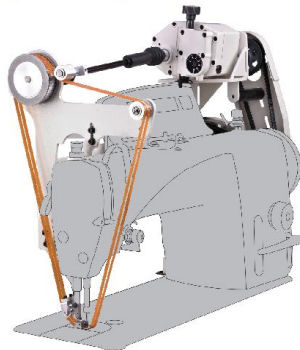

● 適用於各種艱澀·多層·易滑布料
 ● For Tough Abrasive, Multi-Layer and Silky fabric.



拖輪系列配件說明 Description of accessories for pullers

● PW、PR、PG、PO不附電控提昇組
● The roller Lifter is not included for PW, PR, PG, PO.

拉布輪提昇組：當縫紉機壓布腳提昇或自動、手動回針時，拉布輪會同時提昇。
(附有二組輸入接點，可接收自動或觸動回針及壓布腳自動提升電磁鐵信號。)

Roller Lifter : The puller roller will lift at the same time as the foot lifts on the machine. This will work on an auto foot lift machine or with a manually lifted foot.
(The puller comes complete with the micro switches and all the cables required.)

【允許此配件不在購買範圍，不需要此配件時在訂單上註明『不需要拉布輪自動提昇組』，可節省採購成本。
If you do not need the Roller Lifter, please indicate this on your order as the cost will be reduced with "If the reverse solenoid is located on the back of the machine a B base is required."】

電動提昇組：
(標準配件)

**Solenoid Lifter :
(Regular Parts)**



氣動提昇組：
(選擇配件)

**Pneumatic Lifter :
(Optional Parts)**



E3 回針開關
E3 Reverse Switch

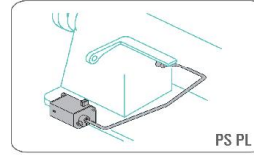

E4 回針開關
E4 Reverse Switch

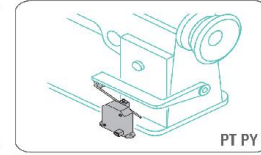

E5 膝動開關
E5 Knee Switch

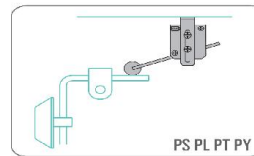

E6 懸吊開關
E6 Suspension Switch

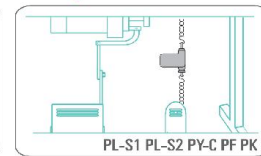

拉布輪提昇高度及操作空間說明 Description of Roller lifting Height and Operation Space for Puller

電動提昇
Solenoid Lifting

A. 標準配件：
Standard Part:

提昇高度：8mm
操作空間：90mm
**Lifting Height: 8mm
Operation Space: 90mm**

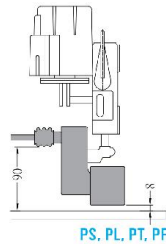

PS, PL, PT, PF

氣動提昇
Pneumatic Lifting

C. 選擇配件：
Optional Part:

提昇高度：15mm
操作空間：98mm
**Lifting Height: 15mm
Operation Space: 98mm**

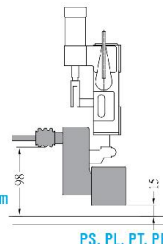

PS, PL, PT, PF

E. 選擇配件：
Optional Part:

提昇高度：45mm
操作空間：225mm
**Lifting Height: 45mm
Operation Space: 225mm**

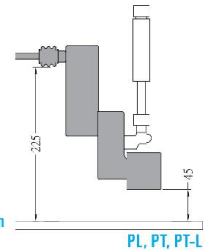

PL, PT, PT-L

B. 選擇配件：
Optional Part:

提昇高度：8mm
操作空間：136mm
**Lifting Height: 8mm
Operation Space: 136mm**

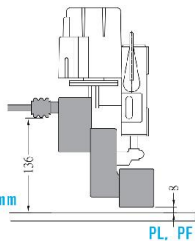

PL, PF

D. 選擇配件：
Optional Part:

提昇高度：15mm
操作空間：145mm
**Lifting Height: 15mm
Operation Space: 145mm**

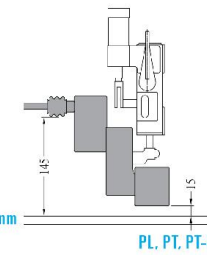

PL, PT, PT-L

F. 選擇配件：
Optional Part:

提昇高度：45mm
操作空間：276mm
**Lifting Height: 45mm
Operation Space: 276mm**

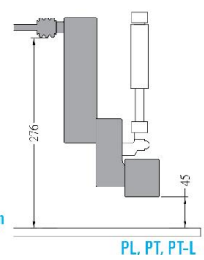

PL, PT, PT-L

B 座：適用於針車背部有回針電磁鐵
B Base : In case the Reverse Solenoid is at the back of Machine.

AK 移位組：適用於針車背部有壓布腳電動提升電磁鐵
AK Relocation Set : If the foot lift solenoid is located on the back of the machine a AK relocation set is required.

例、
EX. BROTHER LT2-B842-403

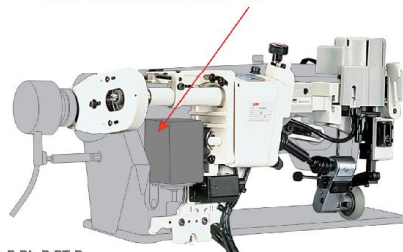

PS-B, PL-B, PT-B

例、
EX. JUKI DDL-5550N-AK

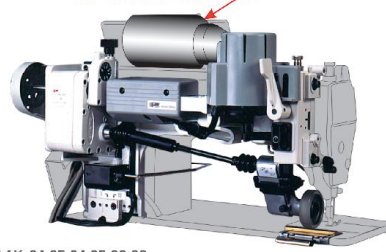

JUKI AK-34 35 84 85 88 89

拖輪訂貨說明

PULLER Order Guide

PL P 5515 BROTHER LT2 B842 - 401

1 ● 機型代號說明
● Puller Model Table

4 ● 安裝之針車廠牌機型
● Adaptable Sewing Machine Brand and Model
5 ● 自動切線及附屬配件編號
● Auto Thread Trimmer or Other Attachment Device No.

機型 MODEL	適用針車 ADAPTABLE MACHINE	
PS	單針、雙針 Single or Twin Needle	輪徑25MM，輪子與車針距離僅20-30MM，適用於薄布料短距離車縫 Roller diameter 25mm. Distance between the roller and the needle is 20-30mm. For sewing short thin pieces of material either curved or straight.
PL	單針、雙針 Single or Twin Needle	輪徑55MM，輪子與車針距離60MM以上，適用於一般厚、薄布料 Roller diameter 55mm. Distance between the roller and the needle is more than 50mm. For general material.
PL-S1	節縫車 Flat Bed Coverstitch	專用基座，輪徑55MM，輪子與車針距離65MM以上，適用於一般厚、薄布料 For general material.
PL-S2	筒型節縫車 Cylinder Bed Coverstitch	專用基座，附下輪，輪徑55MM，輪子與車針距離65MM以上，適用於一般厚、薄布料 Lower roller diameter is 55mm. Distance between the roller and the needle is more than 65mm. For general material.
PT	單針、雙針 Single or Twin Needle	上下輪驅動拉力特強，輪徑55MM，輪子與車針距離130MM以上，適用於薄物到極厚物，長距離車縫 Powerful upper and lower rollers. Upper roller diameter 55mm. Distance between the roller and the needle is more than 130mm. For general material.
PT-L		為長臂型 Same as PT but for long arm machines.
PF	腕型車用 Feed-Off-Arm	輪徑55MM，輪子與車針距離60MM以上，為一般布料用 Roller diameter 55mm. Distance between the roller and the needle is more than 60mm. For general material.
PF-H		為厚物專用，功能同PF Same as PF but for heavy materials.
PF-HB		厚物、極厚物用皮帶式拖輪 Belt driven puller for use on heavy or extremely heavy materials.
PF-RB		一般布料用皮帶式拖輪 Belt driven puller for use with regular fabric.
PF-UB		厚物、極厚物用皮帶式拖輪，適用於US35800機款 Belt driven puller extra heavy duty. Suitable for machines similar to US35800.
PF-FB	四針六線車用 Feed-Off-the-Arm Flatseamer	四針六線車用，適用於各種布料 For use on flatseaming machines. Suitable for all types of fabric.
PY	單針、雙針 Single or Twin Needle	固定於車板，功能同PT Same as PT puller but the PY is fixed to the table.
PY-SP	前拉式單針車 Flatbed Front Puller.	義大利麵專用，固定於車板 For sewing spaghetti straps. Fixed to the table.
PY-C	節縫車 Coverstitch	固定於車板，功能同PT Same as PT puller but for use on coverstitch machines. Fixed to the table.
PK	包縫車用 Overlook	上下輪驅動拉力特強，輪徑55MM，輪子與車針距離200MM以上，適用於薄到極厚物長距離車縫 Powerful upper and lower rollers. Upper roller diameter 55mm. Distance between the roller and the needle is more than 200mm. For thin to heavy duty material.
PK-SP	前拉式包縫車專用 Overlook Front Puller.	義大利麵專用 For sewing spaghetti straps.
PG	包縫車用 Overlook	小輪輪徑28MM，適用於薄物布料 28mm diameter roller. For sewing thin material.
PR	包縫車用 Overlook	齒形皮帶後塗，適用於薄物布料 Material belt led. For sewing thin material.
PO	包縫車用 Overlook	齒形上皮帶塗，適用於各種編織多層、絨布及易滑布料 Belt driven. For use with multi-layer, abrasive and silky material.
PO-F	包縫車用 Overlook	POLO領專用，附包邊器，膝部氣動開關及左右活動導布器 Special for knit shirt collars. With knee switch to open the air type folder. Available for either left or right side operation.
PW	手臂可動型盲縫車用 Bind Stitch With Moveable Arm	皮帶式下塗料，適用於潛水衣布料 Belt driven. For sewing diving suits.
PW-L		長臂型用 Same as PW but for use with long arm machines.

2 ● 輪子材質與外型
● Roller Material & Figures

代號 Code	P	S	T	B
材質 Material	PU 平面 Polyurethane Plain	鐵齒面 Steel Teeth	塑膠齒面 Plastic Teeth	合成橡膠 Synthetic Rubber
外型 Figure				
		PS、PG 不適用 Not For PS、PG		210L1 /mm

※ PS、PG、PO 帶式規格不適用
※ Not For PW、PR、PO Series With Belt Driven Type

3 ● 輪子規格
● Roller Sizes

	D 直徑 Diameter	W 寬度 Width
上輪 Upper roller	55	15, 35, 50
	25	10, 15 (PS 專用) (PS only)
下輪 Lower roller	25	60 (PK 專用) (PK only)
	25	80 (PT, PY 專用) (PT, PY only)
	30	22 (PF 專用) (PF only)

※ PW、PR、PO 帶式規格不適用
※ Not For PW、PR、PO Series With Belt Driven Type

拖輪規格表

PULLER Specification List

功能 Function	機型 Model	PS PS-B	PL PL-B	PL-S1	PL-S2	PT PT-L	PY PY-C PY-SP	PF/PF-H PF-HB PF-RB PF-UB PF-FB	PW PW-L	PG	PR	PO PO-F	PK PK-SP
驅動別 Driven Way		上輪 Upper Roller	上輪 Upper Roller	上輪 Upper Roller	上輪 Upper Roller	上下輪 Upper & Lower Rollers	上下輪 Upper & Lower Rollers	上輪 Upper Roller	下皮帶 Lower Belt	上輪 Upper Roller	後皮帶 Rear Belt	上皮帶 Upper Belt	上下輪 Upper & Lower Rollers
變速機規格 Transmission Type		P-2	P-2	P-2	P-2	P-2 P-2L (選購配件) (Optional Parts) S-1 (選購配件) (Optional Parts)	P-2	PF/PF-H: P-2 PF-HB PF-RB PF-UB: S-1 PF-FB	P-1	P-2	P-2	P-2	P-2
拉布輪與車針距離 (最小) The distance Between the Roller and Needle (MIN.)mm		28	50	65	65	130	150	PF/PF-H: 60 PF-HB: 45 PF-RB: 25 PF-UB: 32 PF-FB: 50	—	40	40	—	200
拉布輪規格 (標準配件) Roller Type (Regular)		P2510	P5515	P5550	T5550 T2560	P5550	P5550K P2580K	PF: P5515 PF-H: S6015 PF-HB/RB PF-UB :210L17 PF-FB	180XL037	P2811	3350MXL08	4750MXL10	P5535K P2560K
拉引長度 (mm) Puller Length (mm)		0.3~6	0.3~6	0.3~6	0.3~6	0.3~8	0.3~6	PF: 0.3~6 PF-H: 0.3~8 PF-UB: 0.3~4.5 PF-FB: 0.3~4	0.3~6	0.3~6	0.3~6	0.3~6	0.3~6
最高縫速 (連續車縫/間歇車縫) Sewing MAX. Speed (Continuous/Intermittent)		4000/6000				PT:4000/6000 PT-L: 3000/4000	4000/6000	PF: :4000/6000 PF-H PF-HB PF-RB PF-UB PF-FB	3000/4000	4000/6000			
電源 Power		AC 100~240V 自動切換 AC 100~240V AUTO SWITCHING											

※ 拖輪系列產品說明
※ PULLER SERIES-PRODUCT SPEC.