



Ron 3050 Crane Scale with 2"/50mm Display

Exceptionally Small dimensions

enable minimum head-room loss.
 For example: Height of the 5t load cell is 16.7 inch / 423 mm



Short delivery time: Usually 2 - 4 business days.

High quality Aerospace Steel for increased strength and safety.

New: Fatigue rated load cells - an important and unique safety feature: All Ron crane scales and dynamometers are now Fatigue Rated. They have an improved fatigue resistance level.

Advanced options such as: Integrated data logger, analog output, averaging / dampening and more.

More than three decades in the market: Eilon Engineering Ltd. has specialized in the development and manufacturing of Ron crane scales and dynamometers since 1976. We have thousands of loyal customers such as NASA, Boeing, US Air Force and many more.

Optional wireless communication to additional display or PC that allows for multiple Ron crane scales / dynamometers in one area to send measurements to a centralized location.

Exceptionally long battery life: Up to 2000 hours on AA disposable batteries with battery life indication.

Optional IR remote control

Optional cage for protection against external impacts: The Protective mechanical cage provides three axis shock absorbing to the system housing by the use of special rubber cushions.

Internal shock protection design: The electronic board is secured on dampening mounts providing additional protection from external shock.

Wide temperature range:
 Load cell: -15°F to +175°F (-25°C to + 80°C)
 Indicator: -4°F to +158°F (-20°C to +70°C).



Ron 3050 Crane Scale with 2"/50mm Display

Description

The Ron 3050 crane scale is compact and yet robust crane weigher.

Its large, 2" / 50mm display enables the user to conveniently read the measured values from a safe distance.

Ron 3050 digital crane scale has a robust extruded aluminum body. Its optional protective cage makes the Ron 3050 even more heavy duty and ideal for harsh working conditions: The protective cage provides absorption from all three axes of mechanical shock to the system's housing by the use of special rubber cushions.

The compact dimensions of the Ron 3050 crane weigher ensure minimum headroom loss.

Ron 3050 advanced technology enables an extremely long battery life of up to 2000 hours on common disposable batteries.

Advanced options increase Ron 3050 suitability to a large variety of projects. Some of these options include integral data logger, additional wireless display that enables transmitting the measured values to a remote destination, and more.

Ron Crane Scales are used for weighing during lifting and for overload prevention and are factory-tested and supplied with a test certificate, including a fully traceable calibration chart.

Eilon Engineering has been designing, constantly improving, manufacturing and selling worldwide Ron Crane Scales and Dynamometers for more than 30 years.



Ron 3050 Crane Scale with 2"/50mm Display

Specifications

Safety Factor: Designed to 5:1, for the load cell and the shackle. Average straightening load of the hook is at least 4 times the capacity.

Proof Load: Each system proof-loaded to 200% of capacity (certified).

Accuracy: $\pm 0.1\%$ of full range.

Durability: Robust, extruded aluminum housing, polyurethane coated.

Display: 5 digit, 2" (50mm) liquid crystal display with two overload warning levels, max. value (peak hold), low battery, tare state (gross or net), measuring unit, sleep state, charge and programming instructions. Standard number of measurements per second: 1. Standard display update rate per second: 1.

Sampling Rate: 200 per second.

Functions: Zero. Tare. Battery charge level. Low battery warning. Max. (peak hold). Two-level overload visual alarms. User calibration. Sleep mode after 60 sec. in zero value, awakes automatically when loaded.

Units: Available in the following measurement readings: metric tons, short tons (2000 lbs), kgs, lbs, newtons, deca newtons, k. newtons.

Load Cell Material: Made of high-strength, aerospace quality, alloy steel.

Power: 3 x AA 1.5 Volt Alkaline disposable batteries, with battery life indication. Batteries rated 3AH will function up to 2000 hours (three months of continuous working). Occasional use will extend the life of the batteries up to several years. Adding certain options will shorten the life of the batteries. All settings retained at power off.

Calibration: User calibration. Initial factory calibration, fully traceable (certified).

Temperature Range:

Load cell: -15°F to $+175^{\circ}\text{F}$ (-25°C to $+80^{\circ}\text{C}$)

Indicator: -4°F to $+158^{\circ}\text{F}$ (-20°C to $+70^{\circ}\text{C}$).

Environmental: Weather proof, NEMA 4, IP65.



Ron 3050 Crane Scale with 2"/50mm Display

Options

- 1 or 2 user-adjustable set points
- Additional 0.5"/12 mm LCD display with cable connection to indicator or wireless.
- Additional 1"/25 mm LCD display with cable connection to indicator or wireless.
- Additional 2"/50 mm LCD display with cable connection to indicator or wireless.
- Additional 4"/100 mm LED display with cable connection to indicator or wireless.
- Analog output: 0 to 1V / 0 to 2V / 0 to 3V
- Analog output: 4 to 20 mA
- Baud rate, user-selectable
- Cage for protection against external impacts
- Dampened (average) display for unstable load
- Data logger – manual or automatic - up to 600 measurements
- Data logger – manual or automatic - up to 3,000 measurements
- Data logger – manual or automatic - up to 6,000 measurements
- Data logger – manual or automatic - up to 10,000 measurements
- IR (infrared) remote control
- Number of measurements per second: Up to 200
- Real-time clock
- Rechargeable batteries with an external charger.
- RS-232 - continuous or on demand data output, user-selectable
- RS-485 - continuous or on demand data output, user-selectable
- Totalizer
- Units, user-selectable
- Wireless communication to additional display or PC
- USB



Ron 3050 Crane Scale with 2"/50mm Display

Dimensions Table and Drawing

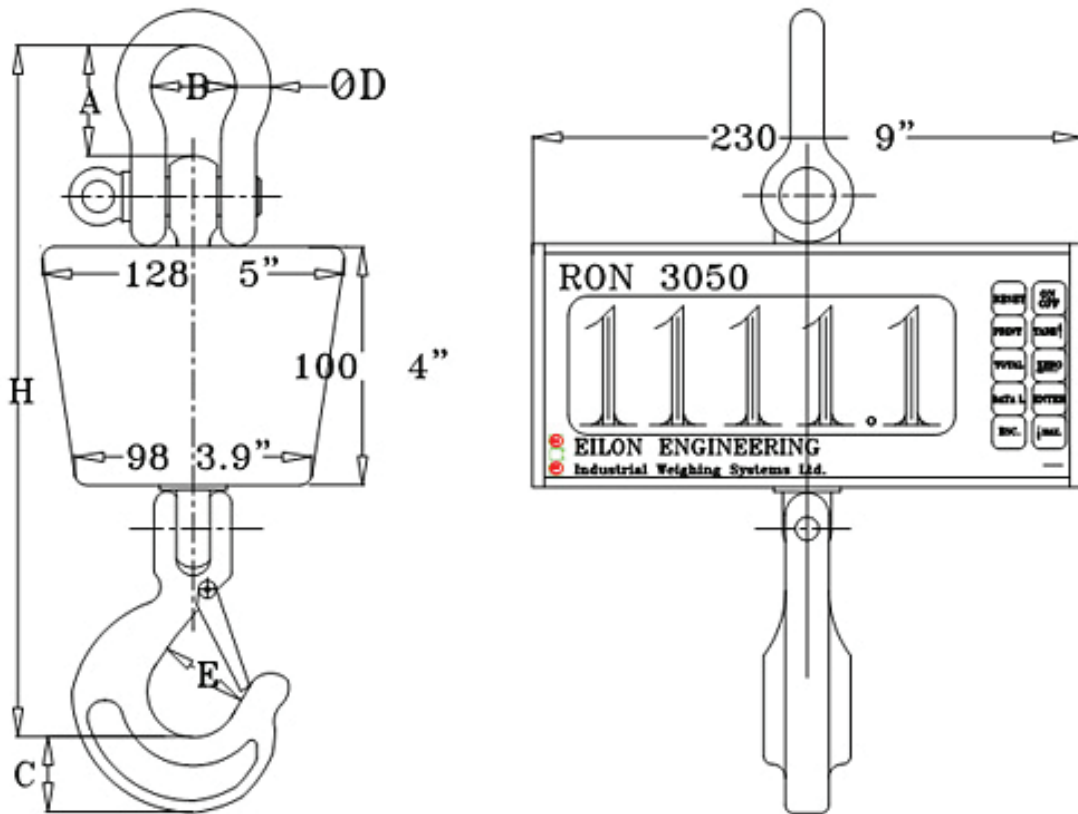

Cat no.	Cap.		Resolution		A		B		C		φ D		E		H	
	tons	kgs	lbs	mm	inch	mm	inch	mm	inch	mm	inch	mm	inch	mm	inch	
CW-005	0.5	0.2	0.5	30	1.2	26	1	31	1.2	10	0.4	25	1	335	13.2	
CW-001	1	0.5	1	30	1.2	26	1	31	1.2	10	0.4	25	1	335	13.2	
CW-012	1.25	0.5	1	30	1.2	26	1	31	1.2	10	0.4	25	1	335	13.2	
CW-016	1.6	1	2	30	1.2	26	1	31	1.2	10	0.4	25	1	335	13.2	
CW-02	2	1	2	30	1.2	26	1	31	1.2	10	0.4	25	1	335	13.2	
CW-025	2.5	1	2	40	1.6	33	1.3	36	1.4	13	0.5	34	1.3	400	15.7	
CW-03	3	1	2	40	1.6	33	1.3	36	1.4	13	0.5	34	1.3	400	15.7	
CW-032	3.2	2	5	40	1.6	33	1.3	36	1.4	13	0.5	34	1.3	400	15.7	
CW-05	5	2	5	50	2	43	1.7	44	1.7	16	0.6	41	1.6	423	16.7	
CW-08	8	5	10	69	2.7	58	2.3	48	1.9	25	1	48	1.8	500	19.7	
CW-10	10	5	10	82	3.2	68	2.7	50	2	25	1	56	2.2	554	21.8	
CW-12	12.5	5	10	82	3.2	68	2.7	50	2	25	1	56	2.2	554	21.8	
CW-15	15	5	10	105	4.3	82	3.2	64	2.5	35	1.4	57	2.2	625	24.6	