

## Custom-built wire ropes

Different ropeway systems and the varying goals of operators worldwide call for wire ropes which are developed and manufactured specifically to meet the exact requirements of the users.

FATZER manufactures haul and track ropes which are optimized through computer design to ensure absolutely correct interaction between the wires.

## FATZER product characteristics

### Low stretch haul/carrying ropes

featuring cores which are being continuously optimized to prevent excessive permanent elongation.

### Compacted haul/carrying ropes

exhibiting a high fatigue limit and advantageous diameter/strength values, also designed to minimize on sheave and bullwheel linings wear.

### Vibration-free haul/carrying ropes

of a special design that largely precludes strand-induced vibration.

### Locked-coil track ropes

with one or more profile wire layers. The twisted construction virtually precludes torque, allowing rope pull without guidance.

## FATZER service

**Project evaluation to determine the ideal rope**

**Support with carrying out disturbance analyses**

**Rope installation and splicing work**

**Rope inspections**

**Maintenance work**

**Rope repairs**

**Advice on the transportation of heavy weight ropes**

## Manufacture

The manufacturing process for rope wires is both costly and complex. The steel, usually melted in converters or electric furnaces, is produced by continuous casting. Contamination or cracks in the steel billets for extra high-grade wires are removed before rolling by grinding, milling or some other means.

The wire rod with a diameter of 5.5 mm and thicker is first pickled, predrawn and depending on the final diameter "patented" on intermediate sizes. "Patenting" is the name given to thermal treatment of the wire in which it is heated to approx. 950 °C and subsequently quenched in a lead bath at a temperature of 450–550 °C. After the thermal treatment, the wire rod exhibits a structure, called sorbite, which makes cold-forming easy. Cold drawing hardens the wire. It has to be patented several times, depending on the final diameter, to restore its deformability. The reduction in cross-section used for the final drawing is 60–85% for thick wires and 70–90% for thin wires, referred in each case to the cross-section of the patented wire.

The strength of the wire is determined by its chemical composition and its overall cross-sectional reduction during cold drawing. The strength of the wire becomes higher as the carbon content and reduction in cross-sectional area increases, whereas its capability for elongation, bending and deformation decreases.

Profile wires for locked-coil or semi-locked-coil ropes are manufactured from steel of the same quality and using the same method as for round wire. Only the production of the required profile shape calls for certain modifications to the manufacturing process. Cold forming is carried out by drawing or rolling the wire or through a combination of the two processes. Unlike the cross-section of round wires, the cross-section of profile wires is not shaped symmetrically by rolling or drawing, with the result that it is not possible to achieve the same high specific breaking strength as for round wires with the same cross-sectional area. For this reason, the breaking load of profile wires shall not be specified too high.

## Rope wires

### Surface and corrosion protection

Rope wires are often surface treated before the final drawing process. For example, the wire is given an iron-phosphate or zinc-phosphate coating (known as bonds), or is alternatively treated with a water-soluble coating of borax. The most common method of providing protection against corrosion is to zinc-coat the wire. The zinc coating can be applied in several different ways.

*Heavily galvanized on final size:* finish-drawn wire is pulled, after cleaning, through a bath of molten zinc at a temperature of 435–450 °C. Due to the heat treatment during the finish coating, the tensile strength of the bare wire that is obtained in the final drawing process is reduced by up to about 10%. The wire is therefore drawn to a tensile strength which is higher than the nominal value, resulting in correspondingly lower bending and torsional values. Tests in the field have shown, however, that this difference does not influence the lifetime of the rope.

*Drawn galvanized:* with this method, the wire does not exhibit the disadvantageous changes in its mechanical properties. The zinc coating is applied in the same way, however after patenting and before the finishing pass. The zinc coating of the finished wire is therefore not as thick as on heavily galvanized wire and is completely smooth and homogeneous.

*Other types of corrosion protection:*

- Zinc coating with aluminium alloy
- Zinc electroplating (galvanizing)
- Copper plating
- Brass plating
- Tinning

### Properties and standard data

Alloy percentages (stand. analyses):

Carbon	0,4–0,9 %
Manganese	0,3–0,7 %
Silicon	0,1–0,3 %
Phosphorus	max. 0,045 %
Sulphur	max. 0,045 %
Nitrogen	max. 0,008 %

Density:	7850 kg/m <sup>3</sup>
or specific weight:	7,85 kg/dm <sup>3</sup>

Nominal tensile strength:	1370–2060 N/mm <sup>2</sup>
---------------------------	-----------------------------

Proportional limit:	40–55% of tensile strength
---------------------	----------------------------

Yield point:	70–85% of tensile strength
--------------	----------------------------

Modulus of elasticity:	approx. 200 kN/mm <sup>2</sup>
------------------------	--------------------------------

Linear coefficient of thermal expansion:	12 x 10 <sup>-6</sup>
or elongation per meter:	0,012 mm per °C temperature difference

Resistivity:	approx. 0,2 Ω mm <sup>2</sup> /m
--------------	----------------------------------

### Wire/test standards

Testing of wires is conducted in compliance with the particular national requirements.

### Wire connections

Wires which cannot be obtained long enough for a certain rope length have to be assembled. The wires are butt-welded by electrical means and the welds annealed to avoid brittle transitional zones. The breaking load of such welds are 40–50% of the nominal breaking load of the wire.

#### Units of force:

#### Newton (N) / Kiloponds (kp) / pounds (lbf)

$$1 \text{ kp} = 9,81 \text{ N} = 2.205 \text{ lbf}$$

$$1 \text{ N} = 0,1019 \text{ kp} = 0.2247 \text{ lbf}$$

$$1 \text{ kN} = 101,9 \text{ kp} = 224.73 \text{ lbf}$$

### Nominal wire strengths

Present unit	Old unit
1370 N/mm <sup>2</sup>	140 kp/mm <sup>2</sup>
1470 N/mm <sup>2</sup>	150 kp/mm <sup>2</sup>
1570 N/mm <sup>2</sup>	160 kp/mm <sup>2</sup>
1670 N/mm <sup>2</sup>	170 kp/mm <sup>2</sup>
1770 N/mm <sup>2</sup>	180 kp/mm <sup>2</sup>
1860 N/mm <sup>2</sup>	190 kp/mm <sup>2</sup>
1960 N/mm <sup>2</sup>	200 kp/mm <sup>2</sup>
2060 N/mm <sup>2</sup>	210 kp/mm <sup>2</sup>

## Strand types

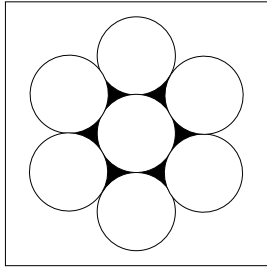

$$1+6 = 7 \text{ wires}$$

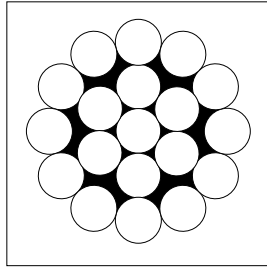

$$1+6+12 = 19 \text{ wires}$$

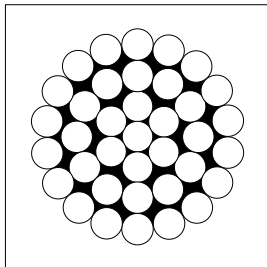

$$1+6+12+18 = 37 \text{ wires}$$

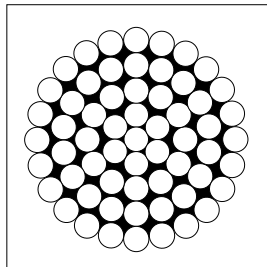

$$1+6+12+18+24 = 61 \text{ wires}$$

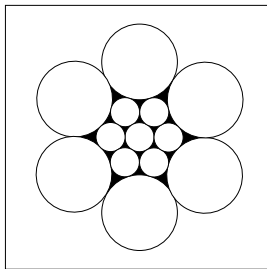

$$1+6+6 = 13 \text{ wires}$$

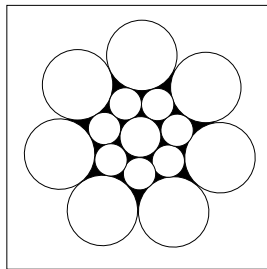

$$1+7+7 = 15 \text{ wires}$$

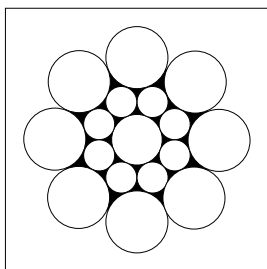

$$1+8+8 = 17 \text{ wires}$$

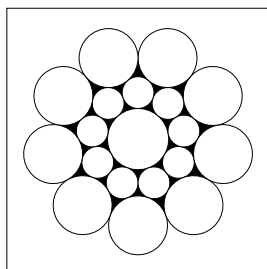

$$1+9+9 = 19 \text{ wires}$$

### Standard

All of the wires, with the exception of the center wire, have the same diameter. The number of wires increases by six with every additional layer. The wires in all the layers cross those lying below them at a narrow angle. As a result there is punctual contact of the wires.

### Seale

The number of wires is the same in every layer. A larger wire diameter therefore has to be chosen for each new layer. Because all the wires lie in the grooves formed by the layer beneath, crossing is avoided. As a result, there is linear contact of the wires. Thomas Seale received a U.S. patent for this design in 1885.

## Strand types

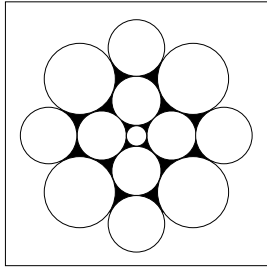

$$1+4+(4+4) = 13 \text{ wires}$$

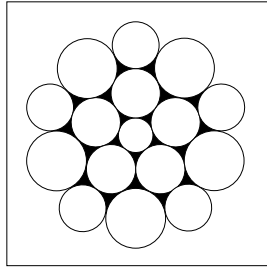

$$1+5+(5+5) = 16 \text{ wires}$$

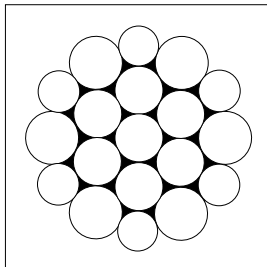

$$1+6+(6+6) = 19 \text{ wires}$$

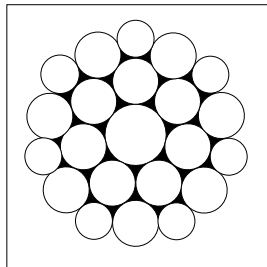

$$1+7+(7+7) = 22 \text{ wires}$$

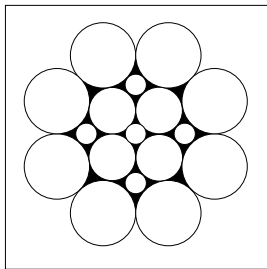

$$1+4+4F+8 = 17 \text{ wires}$$

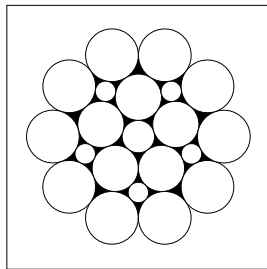

$$1+5+5F+10 = 21 \text{ wires}$$

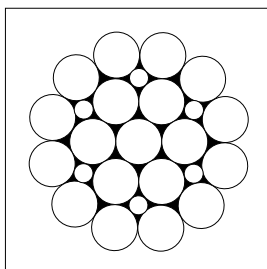

$$1+6+6F+12 = 25 \text{ wires}$$

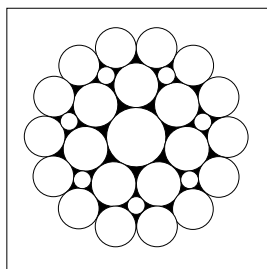

$$1+7+7F+14 = 29 \text{ wires}$$

### Warrington

The wires in the first layer have the same diameter. A wire lies in each of the grooves formed by the first layer. Between these wires lie wires of a smaller diameter. Contact is linear.

### Filler wire (FW)

At least three wire layers have three different wire diameters, although these are uniform in each layer. The number of wires in the first and the filler layer is the same, that of the outer layer double the number. Contact is linear. In a number of countries, the filler wires are not taken into account when calculating the cross-sectional area or when specifying the strand.

## Strand types

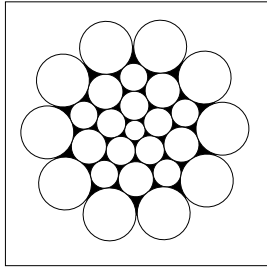

$$1+5+(5+5)+10 = 26 \text{ wires}$$

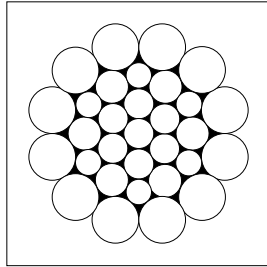

$$1+6+(6+6)+12 = 31 \text{ wires}$$

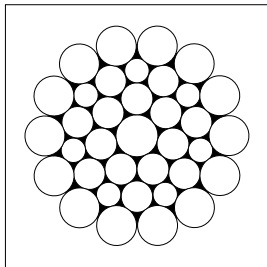

$$1+7+(7+7)+14 = 36 \text{ wires}$$

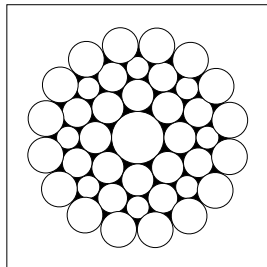

$$1+8+(8+8)+16 = 41 \text{ wires}$$

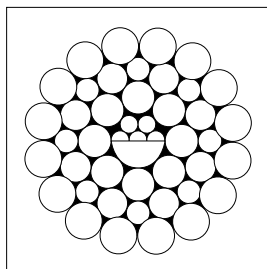

$$(1+6)+8+(8+8)+16 = 47 \text{ wires}$$

### Warrington-Seale (WS)

This is a combination of the Warrington and Seale designs. A Warrington wire arrangement is completed by a covering layer in Seale arrangement. There is linear contact between all of the wires. The diameter of the center wire becomes larger as the number of wires increases.

Sometimes it is expedient to replace the center wire by a strand. This results in a more flexible structure.

The more wires there are, the more flexible the strand will be. Thick outer wires are more suitable in cases of stress due to abrasion or high transverse pressure, while thin outer wires are best suited for applications with high bending values. The direction of lay can be left or right; this has no effect on the design.

## Comparison of strand designs

Each strand design has its own characteristics. The differences between the strands for single-layer, standard and parallel designs are given in the table below.

	Design		
	Single-layer	Standard	Parallel
No. of wire layers	one	at least two	two or more
Type of contact between wires in two adjacent wire layers		punctual contact (wires cross each other)	linear contact (wires lie in parallel)
Direction of lay of wire layers		same or opposing	same
Lay length of wire		different	same
Lay angle of wire		same	different
Wire diameter per wire layer	same (except center wire)	same (except center wire)	different
Wire length per wire layer	same (except center wire)	same (except center wire)	different
No. of operations	one	corresponds to no. of wire layers	one

## Rope designs

Overview of the most common mountain rope designs. The technical data are given in the tables on pages 4.03–4.28.

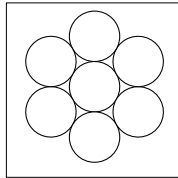

**1x7**  
Page 4.03

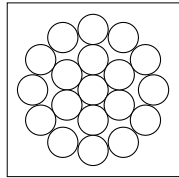

**1x19**  
Page 4.04

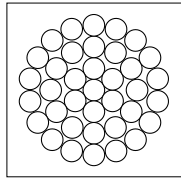

**1x37**  
Page 4.05

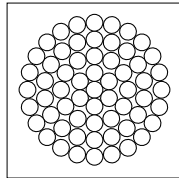

**1x61**  
Page 4.06

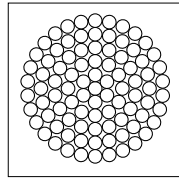

**1x91**  
Page 4.07

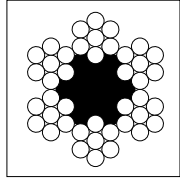

**6x7**  
Page 4.08

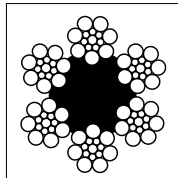

**6x15 Seale**  
Page 4.09

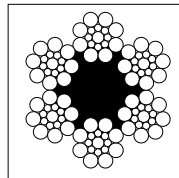

**6x17 Seale**  
Page 4.10

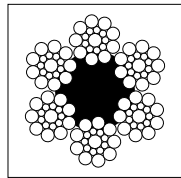

**6x19 Seale**  
Page 4.11

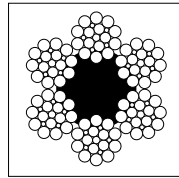

**6x21 FW**  
Page 4.12

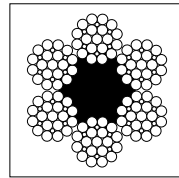

**6x25 FW**  
Page 4.13

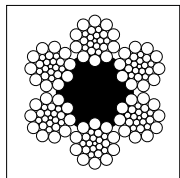

**6x26 WS**  
Page 4.14

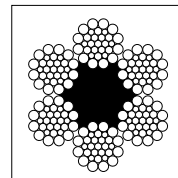

**6x31 WS**  
Page 4.15

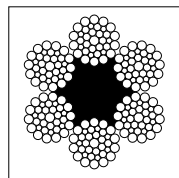

**6x36 WS**  
Page 4.16

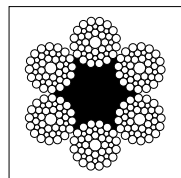

**6x41 WS**  
Page 4.17+4.18

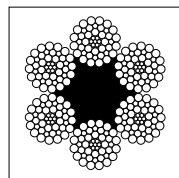

**6x47 WS**  
Page 4.17+4.18

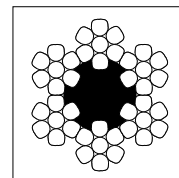

**6x7 comp.**  
Page 4.19

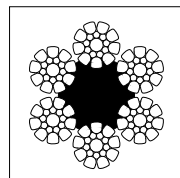

**6x19 comp.**  
Page 4.20

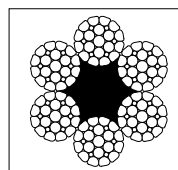

**6x25 FW comp.**  
Page 4.21

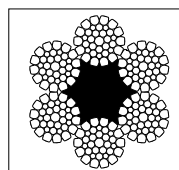

**6x36 WS comp.**  
Page 4.22

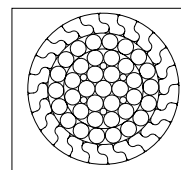

**Locked-coil single-layer**  
Page 4.23+4.27

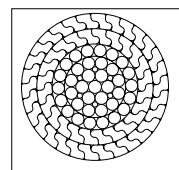

**Locked-coil double-layer**  
Page 4.24–4.25  
+4.27

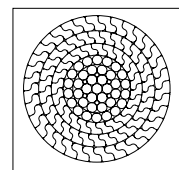

**Locked-coil 3 and more layers**  
Page 4.26

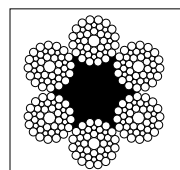

**6x41 WS**  
Page 4.28

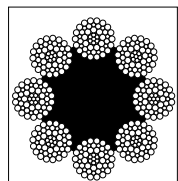

**8x47 WS**  
Page 4.28

comp. = compacted (see pages 3.14–3.15)



In the case of regular lay ropes, the direction of lay of the wires in the strands is opposite to the direction of lay of the strands in the rope.



Regular lay right



Regular lay left



Lang lay right

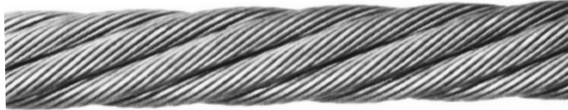

Lang lay left

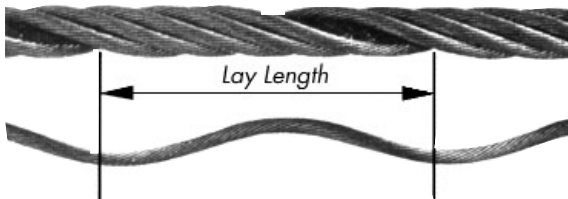

## Lay length

This is the length measured along the axis of the strand or rope for one pitch of the wire or strand.

## Lay angle

The lay angle  $\alpha$  is the angle between the rope and strand axis or the angle between the strand and wire axis.

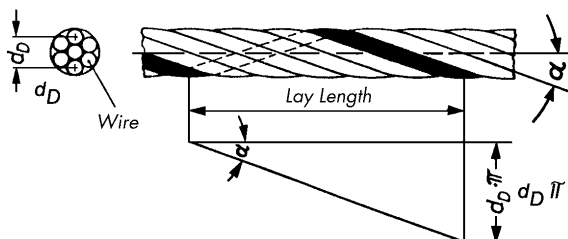

## Stranded ropes

Stranded ropes are manufactured in three operations:

1. Manufacture of the center (core)
2. Spinning the wires into strands
3. Laying the strands to form the rope

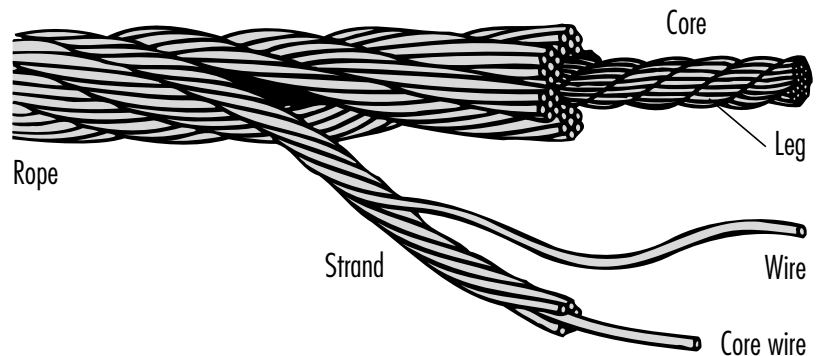

### Core

Filaments made of plastic fibers, e.g. polypropylene, are formed into legs, several of which are spun to form the rope core. Plastic profiles are sometimes used in place of the fiber core.

FATZER manufactures a special core for each new rope order, as it has to be matched precisely to the application.

### Strand **A**

The wires are delivered in coils. Before further processing, they have to be rewound to spools and cut to the specified length. The number of wire spools for the chosen construction are placed in the stranding machine.

This machine consists of three basic units: a rotating part [1], one or two capstan wheels [2] and a take-up device [3]. The rotating part is connected to the capstan unit by gearing. The lay length is selected by setting the gear unit accordingly.

The capstan wheels pull the wires from the rotor through the partitioning plate, closing point and postforming units. The partitioning plate organizes the wires so that they are positioned correctly for the chosen design at the closing point.

When necessary, a lubricant is applied between the partitioning plate and the

closing point. The strand is given its final balance in the postforming unit. The appropriate spool in the winder takes the strand up for further processing.

### Rope **B**

The principle of operation of the machine is the same as for the machine used to manufacture the strands. The difference lies in the smaller number and larger capacity of the reels. The capstan wheels pull the strands through the preforming apparatus to give them their helical shape. They are closed around the rope core at the closing point. The rope is given its final balance in the postforming unit, after which it passes over the capstan wheel before being wound directly onto the transport reel.

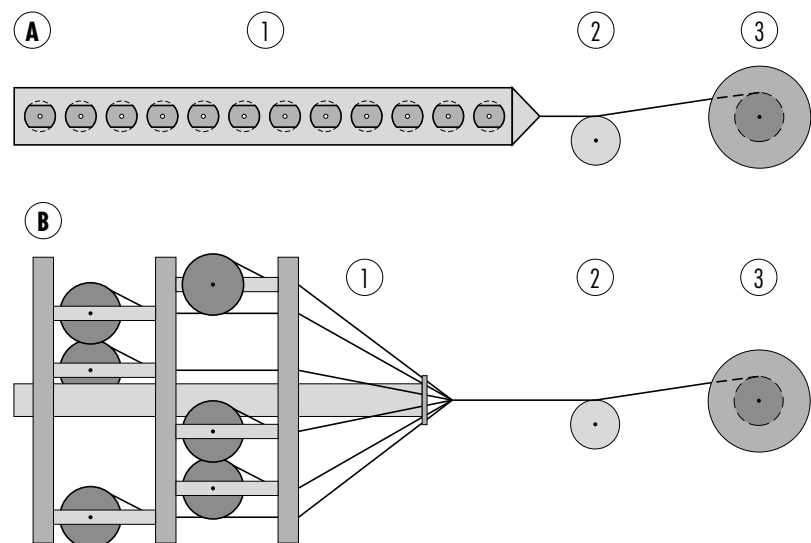

## Locked-coil ropes

Locked-coil ropes are manufactured in several operations:

1. Manufacture of the core strand
2. Application of one or more round-wire layers
3. Application of one or more profile wire layers

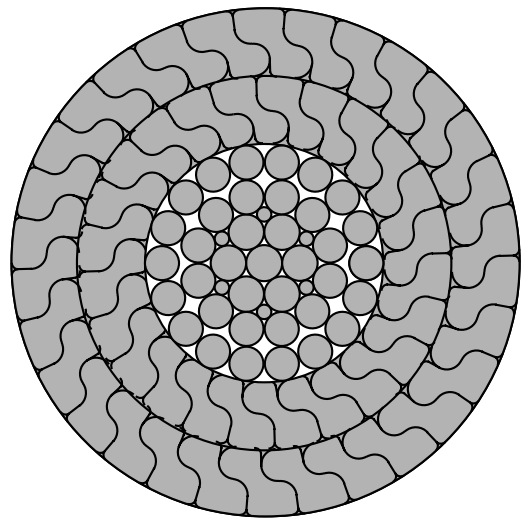
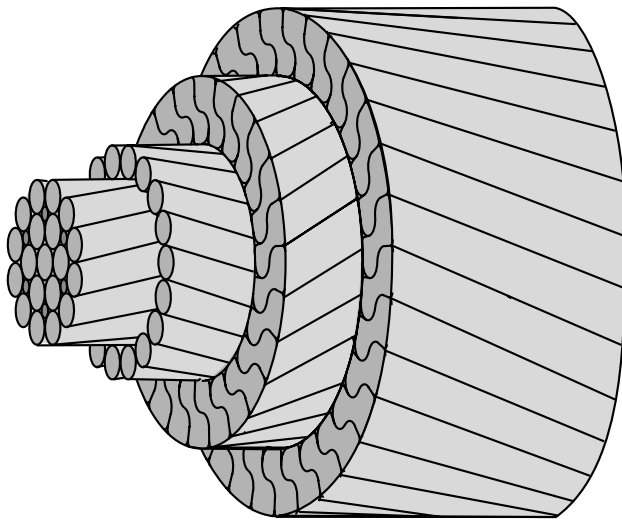

As a rule, the core strand consists of a parallel construction onto which the layers of wires are applied in alternate directions of lay.

To ensure that the Z-profile wires retain their forced helical shape in the finished rope, they are preformed in the twisting apparatus prior to closing. Locked-coil ropes of twisted design are largely free of torque, allowing rope pull without a guide.

The cavities of locked-coil ropes are completely filled with grease to avoid internal corrosion being caused by condensation water. FATZER supervises the supply of grease during rope manufacture to ensure that all cavities are completely filled with grease over the full length of the rope.

**'Permanent elongation'** refers to a permanent increase in the length of the rope.

**'Elastic elongation'** refers to the linear variation in length of the rope as a function of force and temperature.

The change in length of wire ropes is determined by three main factors. These are:

- The elasticity of the rope
- The thermal expansion
- The permanent elongation resulting from the setting

The rope elongates under load and/or thermal conditions as a function of the modulus of elasticity and the linear coefficient of thermal expansion. This elastic elongation recedes when the force is removed and/or cooling takes place (for data, see page 3.13). The extension, caused by setting of the rope, results in a permanent change in the rope's length.

## Change in length

The permanent elongation of a wire rope varies over the course of its service life, being greater at the beginning and afterwards increasingly smaller. The permanent elongation is caused primarily by the strands working their way into the fiber core. When the rope is being used, the core is subjected to constant compressive stress caused by the radial force exerted by the strands. Also, the strands move relative to the core every time the rope bends, for example when it passes the sheaves and wheels. Due to this movement, the strands work into the core, making the rope slightly thinner and longer.

The compressive stability of the core has a decisive influence on the setting properties of the rope. The number of legs, the method of spinning, the quantity of grease content and the type of lay are other key factors.

The permanent rope elongation occurring with modern-day cores lie in the order of 0.1 to 0.2 percent. The options which are available are:

- Polypropylene fiber cores
- Thermocompact<sup>®</sup> fiber cores
- Fullplast<sup>®</sup> solid plastic cores

## Characteristic data of wire ropes

### Modulus of elasticity

Stranded ropes with fiber core	70–100 kN/mm <sup>2</sup>	Linear thermal expansion	12 mm per km and °C
Stranded ropes with steel core	100–125 kN/mm <sup>2</sup>	Resistivity	0,2 Ω per mm <sup>2</sup> /m
Single stranded ropes	125–145 kN/mm <sup>2</sup>		
Locked-coil ropes	145–170 kN/mm <sup>2</sup>		

### Approximate elastic elongation values for different types of rope

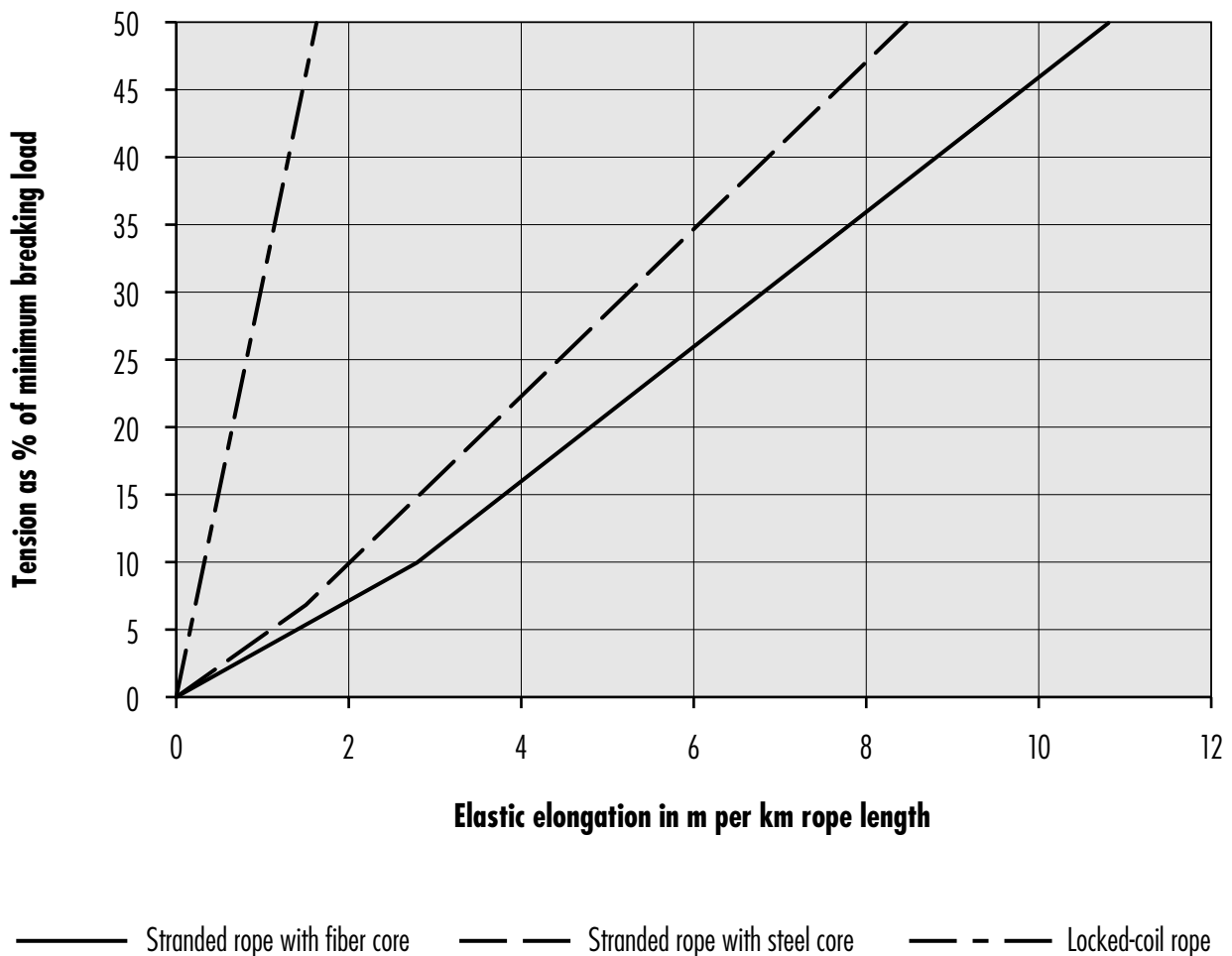

## Compacting of mountain wire ropes

The term 'compacting' describes the reduction of the strand or rope diameter through the application of special measures. Compacting is achieved by drawing, rolling or swaging.

### Drawing

Compacting by means of drawing takes place during the manufacture of the strands. The wires are drawn through a special die, which compacts them.

### Rolling

Compacting by means of rolling takes place during the manufacture of the strands as well as the ropes. The strands/ropes are drawn through calibrating rolls located after the closing point, thereby being compacted.

### Swaging

Compacting by means of swaging (hammering) is carried out as a rule on the finished rope and involves a special operation. The rope passes through the swaging machines, the dies of which are adapted to the rope diameter. The dies hammer the rope at a high frequency as it passes through, compacting it by reducing its diameter.

FATZER mountain wire ropes are compacted by means of drawing or rolling.

The purpose of these measures is to increase the filling factor of the strands. Through the use of suitable production equipment (dies or rolls) the outer wires are plastic shaped in a way that improves the metallic filling of the cross-sectional area. This has several advantages: due to the higher filling factor of the strand cross-section, the breaking force can be increased by approx. 10%. Flattened outer wires result in lower pressures per unit surface area at the grip and sheave locations, or, in the case of the strands touching due to the larger contact surface, to smaller peak stresses. The contact lines become contact surfaces, which reduces the local surface pressure (see figure). These advantages increase the service life of the mountain rope. The rope weight per unit length is increased by the better utilization of the metallic strand cross-section.

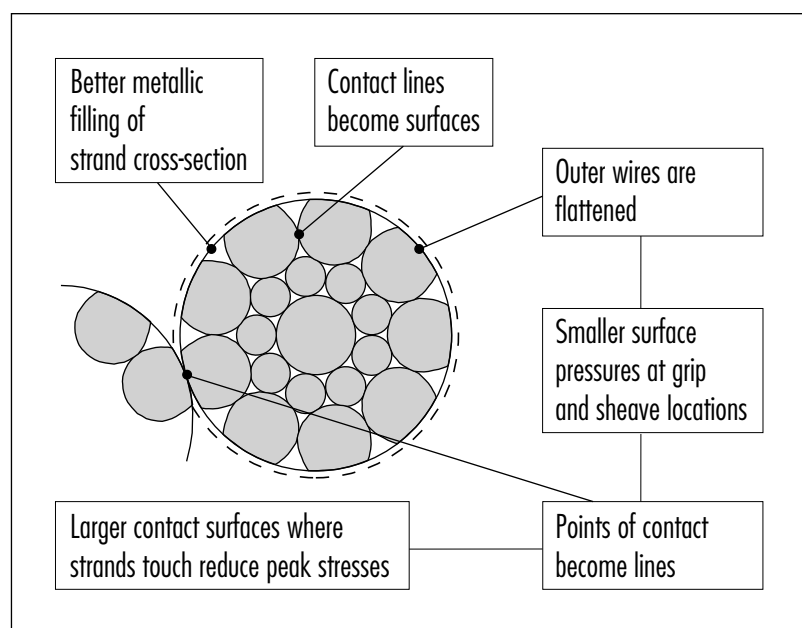
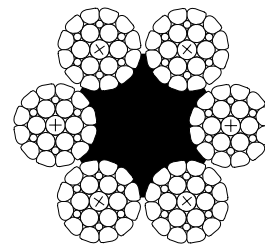
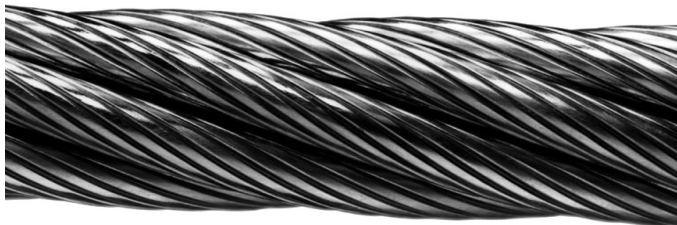

Figure:  
Advantages of compacting the strands used in mountain wire ropes.

## Features of compacted mountain wire ropes

- Larger metallic cross-sectional area
- Reduced nominal diameter compared with normal ropes for same rope breaking load
- Use of lower nominal wire strength for same rope diameter and same rope breaking load
- Higher rope weight compared with normal ropes for same rope diameter
- Quieter in use due to 'smoother' surface
- Reduced wear on rollers, drive and deflection sheaves
- Better utilization of the D:d ratio
- Necessity of a special wire quality
- Higher manufacturing costs
- Less sensitive response to external mechanical influences, which extends the lifetime



**compacted**

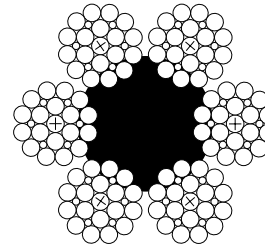
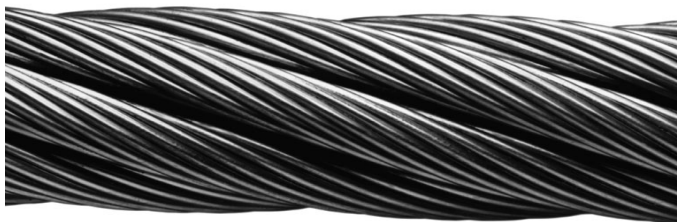

**non-compacted**

## **Dynamic pretensioning of carrying-hauling ropes**

Increasing demand for longer and thicker carrying-hauling ropes induced FATZER several years ago to thoroughly look into the problems involved in rope stretching.

The manufacture of hard fiber cores, additionally compacted during cabling, resulted in a considerable improvement. Nevertheless, when in service the strands are subjected to a certain tensile load which presses them further into the core. The rope diameter is consequently reduced and the rope increases in length.

This effect can be decisively influenced by means of dynamic pretensioning during manufacturing. The rope is thereby subjected to an increased tension which is both permanent and constant, causing controlled embedding of the strands in the fiber core. At the same time, and this is an important

factor since it improves the lifetime of the rope, the differences in tension in the strands within the rope lock are considerably reduced. The pretension which is applied is variable and can be set as required (see diagram of pretensioning installation). This procedure leads to a significant reduction in rope elongation and in most cases dispenses with the need to shorten the rope during the first season of use.

It has to be said, however, that a certain amount of the prestretching effect is lost during take-up of the rope in the factory and during its installation on site. For this reason, FATZER recommends that even dynamically pretensioned ropes be kept under service tension for a certain period of time (48 to 72 hours) prior to splicing to allow the condition achieved by prestretching to be re-established.



## PRETENSIONING

### Basic set-up of pretensioning installation

- 1 Closing cage
- 2 Spool with rope core
- 3 Preforming head
- 4 Pneumatic dies
- 5 Post-forming rollers
- 6 Deflection wheel
- 7 Hydraulic disk brakes
- 8 Automatic control valve
- 9 Control for adjustment of rope tension
- 10 Dynamic pretensioning device
- 11 Capstan
- 12 Fairlead
- 13 Take-up reel

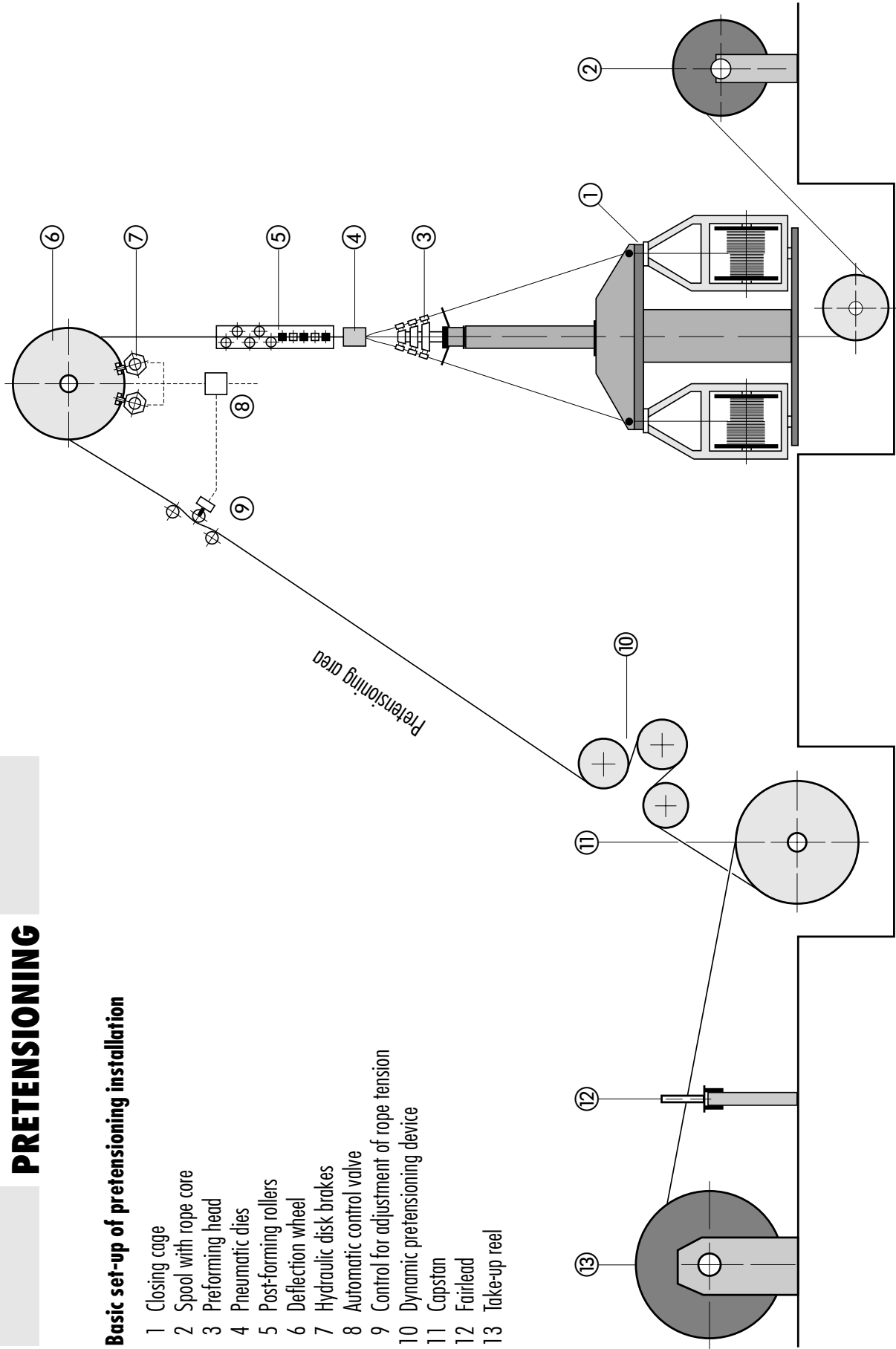

## Minimization of strand-induced vibration

The interrelationships involved in strand-induced vibration have been studied in detail by Oplatka [1]. Based on his investigations, the following statements can be made:

- The cause of strand-induced vibration is the corrugated surface of the rope.
- The vibrations are excited when the rope passes over the sheave battery.
- By matching the length of lay to the distance between the roller axes, strand-induced vibration can be reduced, although it can never be completely eliminated.

A linear relationship exists between the rope lay length and the rope diameter (see fig.). When selecting the length of lay, this leads to a compromise between the rope elasticity on the one hand and the breaking load on the other. The geometry of the sheave rocker is another factor influencing the choice of lay length, and may require a revision of the compromise. If the necessary deviation is too large, the rocker geometry has to be modified to suit when this is possible.

To minimize the strand-induced vibration in ropes with a diameter larger than 35 mm, FATZER recommends, whenever possible, letting the rope manufacturer modify the lay length to optimize it with respect to the rocker geometry.

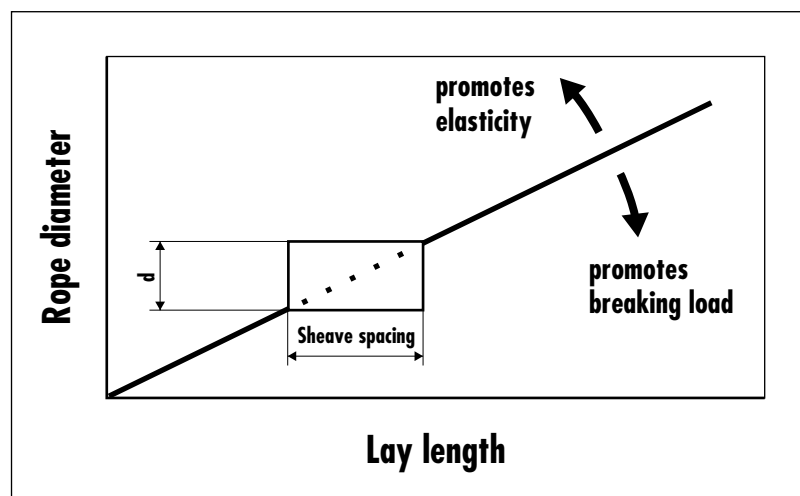

Figure:  
Relationship between rope diameter  
and lay length of the strand.

Reference:

- [1] Oplatka: litzenduzierte Vibration von Rolle und Seil  
(strand-induced vibration of rollers and ropes)