



# LIGHTING CATALOG



WHEREVER THE JOB TAKES YOU,  
**COUNT ON JAMESON™**





# LIGHTING SOLUTIONS

**TO MEET THE DIVERSE APPLICATION NEEDS**

For over 25 years, Jameson continues to provide an extensive lighting solution to meet the diverse application needs of our customers. As a trusted and reliable source, we provide quality lighting products and a customer-friendly resource in the design and execution for lighting applications.

We strive to provide the best in high quality LED work lights that are flicker-free, and doesn't interfere with tone test equipment. This technology provides intense light in small spaces for electrical and telecommunication rooms, manholes, garages, and other application needs.

In early 2000 our team of engineers revolutionized expeditionary lighting by creating stringable shelter lights that are lightweight, energy efficient, portable and offer easy set up. Our lights are actively used for a wide variety of missions in all branches of the US Military and are an integral part of various shelter programs.

Our LED equipment lights are designed to withstand extreme environmental conditions and operational applications found in mining and construction.



## STUBBY® FLUORESCENT WORK LIGHTS

Compact, High Intensity Lighting For Small Work Spaces

### Durability and Performance in Twin Lamp Design

- Twin tube compact fluorescent lamp
- Flexible hanging hook for mounting convenience
- Shock-absorbing handle and end cap combined with shatter-proof tube shield for rugged durability
- IP44 splash proof enclosure
- Damp Location rated
- Service grade rubber cord for ultimate durability and oil resistance
- Remains flexible in cold temps

### Electronic Ballast Technology

- Eliminates cumbersome starter canisters
- Reduces heat output
- Flicker free lighting
- Does not interfere with tone test equipment
- Rapid start



Two large, flexible hanging hooks on 24, 36 and 50 watt lights. One hanging hook on 13 watt light.

### STUBBY® 110 VOLT FLUORESCENT LIGHTS

Part Number	Rated Lamp Power	Cord Length	Weight (Lbs)
31-1325E	13 Watts	25 ft.	2.7
31-1350E	13 Watts	50 ft.	4.5
31-2425E	24 Watts	25 ft.	3.6
31-2450E	24 Watts	50 ft.	5.3
31-3625E	36 Watts	25 ft.	4.0
31-3650E	36 Watts	50 ft.	5.8
31-5025E	50 Watts	25 ft.	4.2
31-5050E	50 Watts	50 ft.	5.9

Available with 25 ft. or 50 ft. Power Cord. NEMA 1-15 plug



10 Watts - 15"

## STUBBY® LED WORK LIGHTS

Long-Life LED Lighting In A Compact Design

- LED technology for longer life and reduced power consumption
- Compact design for small workspaces
- Flexible hanging hook for convenience
- Shock-absorbing handle and end cap combined with shatterproof tube shield for rugged durability

### STUBBY® 120-240 VAC LED LIGHTS

Part Number	Rated Lamp Power	Cord Length	Weight (Lbs)
31-825-LED	10 Watts	25 ft.	5.0
31-825-LED-R*	10 Watts	25 ft.	5.5
31-850-LED	10 Watts	50 ft.	6.0

Available with 25 ft. or 50 ft. Power Cord

\* Items Ending In "-R" Are Provided In Display-Ready Packaging

## STUBBY® 8 WATT LED 12 VDC (5-14 VDC Range)

Ideal for emergency applications when power is not available; equipment rooms or basements where water is a concern; utility and supervisor vehicles. 10 ft. coil cord and plug adapter.

- Operates off battery pack or direct 12 Volt power source

Part Number	Rated Lamp Power	Cord Length	Weight (Lbs)
31-12VDC-LED	12 Volt (Light Only)	10 ft.	6.9



13 Watts - 15"

## HANDI-LIGHT® FLUORESCENT WORK LIGHTS

### Bright, Durable Workspace Lighting

Convenient Lighting in Single Lamp Design

- Single fluorescent lamp
- Two flexible hanging hooks for convenience
- Shock-absorbing handle and end cap combined with shatter-proof tube shield for rugged durability
- IP44 splash proof enclosure and damp location rated
- Service grade rubber cord for ultimate durability and oil resistance. Remains flexible in cold temperatures.
- 110 Volt

### Electronic Ballast Technology

- Eliminates cumbersome starter canisters
- Reduces heat output
- Flicker free lighting
- Does not interfere with tone test equipment
- Rapid start



15 Watts - 26"



30 Watts - 44"



40 Watts - 56"

### HANDI-LIGHT® 110 VOLT FLUORESCENT LIGHT

Part Number	Rated Lamp Power	Cord Length	Weight (Lbs)
30-1525E	15 Watts	25 ft.	3.3
30-1550E	15 Watts	50 ft.	5.1
30-3025E	30 Watts	25 ft.	4.1
30-3050E	30 Watts	50 ft.	6.0
30-4025E	40 Watts	25 ft.	6.6
30-4050E	40 Watts	50 ft.	8.7

Available with 25 ft. or 50 ft. Power Cord

# LIGHTING - PORTABLE WORK LIGHTS

## HANDI-LIGHT® LED WORK LIGHTS

### Long-Life LED Lighting

#### Portable Work Light with LED Durability

- LED technology for longer life and reduced power consumption
- Two flexible hanging hooks for convenience
- Shock-absorbing handle and end cap combined with shatterproof tube shield for rugged durability
- High color rendering index makes identifying wire colors easier

#### LED Lamp Specifications

- Raw lumens: 1136 lumens
- Color temp: 5000K
- RoHS compliant
- Lamp rated life: 50,000 hours (L70)
- No glass
- Mercury free
- 100% recyclable
- Equivalent light output of 17 Watts, T8 fluorescent
- Suitable for damp locations
- CRI of 85

#### Light Specifications

- Voltage input 120 to 277 VAC
- Amp draw .08A at 120 VAC



9 Watts - 31"

Part Number	Rated Lamp Power	Cord Length	Weight (Lbs)
30-925E-LED	9 Watts	25 ft.	3.3
30-925E-LED-R*	9 Watts	25 ft.	3.5
30-950E-LED	9 Watts	50 ft.	4.8

## ACCESSORIES FOR STUBBY® & HANDI-LIGHT®



Part Number	Description
29-01	12 Volt DC Inverter
Operates light off vehicle's 12 Volt DC power source 75 - 100 Wattage Rating	



Part Number	Description
23-15	29 in. Vinyl Carry Bag
23-30	46 in. Vinyl Carry Bag
23-40	50 in. Vinyl Carry Bag
Protects and transports light Available in three lengths	

\* Items Ending In "-R" Are Provided In Display-Ready Packaging

## LED RECHARGEABLE CLAMP LIGHT

### Versatile Clamping/Free-Standing Design

900 lumen portable USB rechargeable work light. Carry it, clamp it, place it anywhere. Ultra-bright wide-angle LED output is perfect for workshop, job site, garage, home, and outdoor recreation use.

- High-performance LED provides 900 lumen wide-angle output
- Lightweight, integrated Li-Ion battery and USB charging provides ultimate portability
- Dual-brightness settings provide up to 7-hour long-lasting run-time
- Versatile clamp-light or free-standing work light design
- Non-marring pads clamp to wood framing, pipes, doors, and more.
- Two-axis rotating head swivels for perfect aiming
- Indoor/Outdoor use, rated IP54 rainproof/dustproof
- Durable impact-resistant design, folds flat for compact storage



Part Number	Description
31-W900-BY	900 lm LED wide-angle clamp light with USB Li-Ion rechargeable battery

Specifications	
Maximum Power	9 Watts
Light Source	LED
Maximum Lumen Output	900
CRI	80
CCT	6500 K
Beam Angle	Wide
Charging Input	5V USB
Run Time	2 hours at 100% (High Mode) 7 hours at 30% (Low Mode)
Charging Time	4.5 hours
Charging Cable	3.0 ft. USB to Micro USB
Housing Material	PC, ABS, PP
Battery type	3.7 V / 4400 mAh
Operating/Charging Temp	-10°C - 40°C (14°F - 104°F)
Dimensions: L x W x D	7.4 x 3.8 x 10.4 in. 189 x 96 x 264 mm
Weight	1.9 lbs (0.85Kg)
Electrical Class	Class III
Ingress Protection	IP54 (dustproof, rainproof)
Impact Rating	IK07

#### H/VAC-R



#### TELECOMMUNICATION

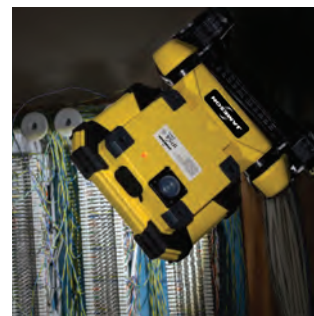

#### NETWORK

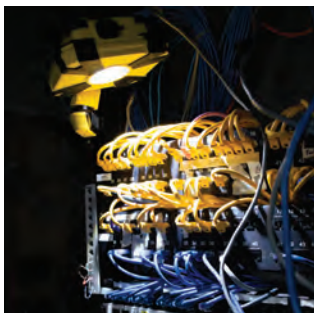

#### ELECTRICAL



## LED RECHARGEABLE HEADLAMP

Rechargeable LED headlamp is versatile and extremely durable. The 31-HDLP Headlamp has 3 different light modes: Flood Light, Spot Light, and Up-Close Light. It is made of impact-resistant materials, which are dust and water resistant, and strong enough for the toughest conditions. The motion-activated sensor allows you to turn the headlamp on and off with a wave of your hand. The Jameson headlamp is perfect for indoor and outdoor work sites, and emergency situations.

- Lumen Output: 250 / 150 / 120
- 3 Modes: Flood, Spot and Up-Close
- Runtime: Up to 3 hours
- IP65 Dust & Water Resistant Rated
- IK07 Impact Resistant
- Glow-in-the-Dark Reflector illuminates after use for easy locating
- LED Blinks to warn user battery is dying
- Detachable: Can be used as a small hand light or stationary light utilizing magnet
- Comes with 4 hard hat mounting clips



Part Number	Description
31-HDLP	Rechargeable LED Headlamp

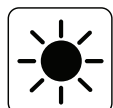

Spot: 150 lumen  
Flood: 250 lumen  
Bottom: 120 lumen

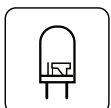

Spot: High power LED  
Flood: COB LED  
Bottom: COB LED

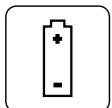

3.8V/1600 mAh  
Li-poly

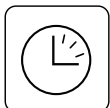

Spot: 2.5h  
Flood: 2.5h  
Bottom: 3h



Charge Time  
2-3h

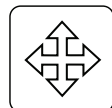

3.25" x 2.25" x 1.75"

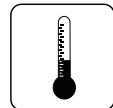

32°F to 110° F



Impact  
Resistance



IP65



0.3 lbs.

### MOTION ACTIVE SENSOR



### GLOW IN THE DARK LOCATOR



### DETACHABLE



### MULTI-MODES

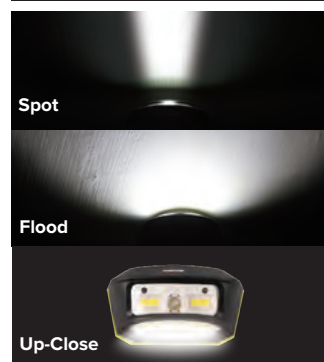



## LED EQUIPMENT LIGHTS TOUGH LIGHTING FOR TOUGH JOBS

Jameson offers a diverse line of lights to meet the unique applications of our customers.

### **XD EXTREME DUTY LED LIGHTS**

Features a rugged design with our highest-shock handling capabilities for extreme environments mining, military, marine or tracked equipment. XD lights carry a five (5) year warranty.

### **HDI HEAVY DUTY ILLUMINATION LED LIGHTS**

Make it easier and safer to work at night with the brightness and durability customers require for utility, agriculture, construction, forestry and off-road applications. HDI lights carry a three (3) year warranty.

### **JLITE LED LIGHTS**

Offers versatile lighting for a variety of applications, including light construction vehicles, utility trucks, forklifts, ATV's, golf carts, boats and more. JLites comes with a one (1) year warranty.



## XD EXTREME DUTY LED EQUIPMENT LIGHTS Rugged Design With Our Highest-Shock Handling Capabilities

Our XD LED Equipment Lights offer the intensity, durability and power needed for heavy equipment in environments with extreme temperatures or high shock and vibration applications.

The XD is preferred for mining, marine or tracked equipment applications.

- 50G HALT testing ensures superior performance under extreme shock and vibration
- Double-bolt XD-Lock™ mounting system isolates housing from mounting bracket for high-frequency vibration dampening
- Housings are machined billet aluminum for optimal thermal transfer, maximizing LED life and efficacy
- Type II anodized aluminum housing for corrosion protection (Mil-A-8625)
- Corrosion resistant stainless steel mounting bracket
- IP69K – Withstands high-temperature/high-pressure water jets
- Advanced thermal management extends LED life at high temperatures and increases effective lumens at low temperatures.
- Zero warm-up for instant-on, flicker-free lighting
- Borosilicate glass lens resists scratches and repels dust
- Energy efficient - Low power consumption provides more lumens per watt compared to HID's
- Reverse polarity protection
- Extreme high and low temperature performance
- Extended Five (5) Year Warranty



Part Number	XD9	XD16	XD32	XD80
<b>Specifications</b>				
Effective Lumens @ 25°C	3000	5900	11800	24800
Number of LEDs	9	16	32	80
Beam Patterns	Spot, Medium, Vertical Elliptical, Horizontal Elliptical, Wide, Trapezoid		Spot, Medium, Wide, Vertical Elliptical, Trapezoid	Spot, Medium, Wide, Horizontal Elliptical, Trapezoid
Shock/Vibration	50G RMS @ 10-10,000 Hz at -40°C (-40°F)			
Ingress Protection	IP69K			
Power	45 Watts	85 Watts	170 Watts	270 Watts
Current	3.8 A @ 12 VDC 1.9 A @ 24 VDC	7.1 A @ 12 VDC 3.5 A @ 24 VDC	14.1 A @ 12 VDC 7.0 A @ 24 VDC	22.5 A @ 12 VDC 11.3 A @ 24 VDC 2.4 A @ 120 VAC
Input Voltage	10-32 VDC			18-32 VDC or 90-277 VAC
Operating Temp	-75°C - 90°C (-103°F - 194°F)			-75°C - 90°C (-103°F - 194°F) DC Version -40°C - 70°C (-40°F - 158°F) AC Version
Color Temp (CCT)	5000K Natural White			
Weight	2.0 lbs (0.9 kg)	3.1 lbs (1.4 kg)	5.3 lbs (2.4 kg)	16.4 lbs (7.4 kg) DC Version 19.5 lbs (8.8 kg) AC Version
Dimensions	5.0 x 4.5 x 3.6 in.	5.6 x 5.2 x 3.9 in.	9.0 x 4.9 x 3.9 in.	19.5 x 6.3 x 6.3 in.
LED Life (L70)	50,000 Hours			
Termination	Chassis Mounted Deutsch	Chassis Mounted Deutsch Chassis Mounted Amphenol	Chassis Mounted Deutsch	Wire Leads

## XD EXTREME DUTY LED EQUIPMENT LIGHTS

### XD Series Ordering Guide - Use Table To Determine Part Number

#### EXAMPLE PART NUMBER: XD9D04510NGDS

XD9 with deutsch connector, 45 watts, 10 volts, natural white LEDs, borosilicate glass lens, double trunnion, spot beam pattern  
(see page 23 for additional information on beam patterns)

XD9	D		045	10		N		G		D		S	
Series	Termination		Power (Watts)	Input Voltage		LED Color		Lens		Mount Style		Beam Pattern	
XD9	D	Deutsch Connector	45	10	10-32VDC	N	Natural White	G	Borosilicate Glass	D	Double Trunnion	S	Spot
				M	Medium								
	18	18-32VDC	V	Vertical Elliptical									
			H	Horizontal Elliptical									
			W	Wide									
			T	Trapezoid									



**XD9**

XD16	D		085	10		N		G		D		S	
Series	Termination		Power (Watts)	Input Voltage		LED Color		Lens		Mount Style		Beam Pattern	
XD16	D	Deutsch Connector	85	10	10-32VDC	N	Natural White	G	Borosilicate Glass	D	Double Trunnion	S	Spot
				M	Medium								
	M	Amphenol Connector	18	18-32VDC	V	Vertical Elliptical							
					H	Horizontal Elliptical							
					W	Wide							
					T	Trapezoid							



**XD16**

XD32	D		170	10		N		G		D		S	
Series	Termination		Power (Watts)	Input Voltage		LED Color		Lens		Mount Style		Beam Pattern	
XD32	D	Deutsch Connector	170	10	10-32VDC	N	Natural White	G	Borosilicate Glass	D	Double Trunnion	S	Spot
				M	Medium								
	18	18-32VDC	V	Vertical Elliptical									
			W	Wide									
			T	Trapezoid									



**XD32**

XD80	C		270	18		N		G		D		S	
Series	Termination		Power (Watts)	Input Voltage		LED Color		Lens		Mount Style		Beam Pattern	
XD80	C	Cable Leads	270	18	18-32VDC	N	Natural White	G	Borosilicate Glass	D	Double Trunnion	S	Spot
				M	Medium								
	AC	90-277VAC	H	Horizontal Elliptical									
			W	Wide									
			T	Trapezoid									



**XD80**

#### NOTE:

- ALL Deutsch connector versions include mating half Deutsch connector with lead wires.
- XD16 with Amphenol connector does not include mating connector half.

## XD EXTREME DUTY LED EQUIPMENT LIGHTS

### Beam Patterns

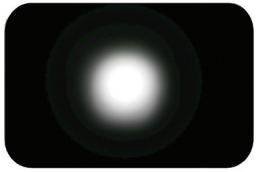

**Spot**  
11°

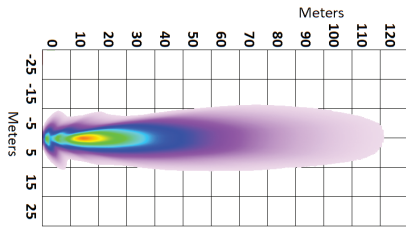

#### Spot

Focused for far field viewing; needed for spot-lighting and high-speed driving. Use on haul trucks and other swift-moving vehicles. Effective for high beam headlight applications.

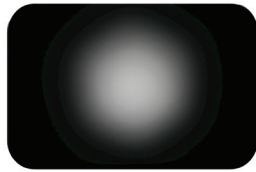

**Medium**  
26°

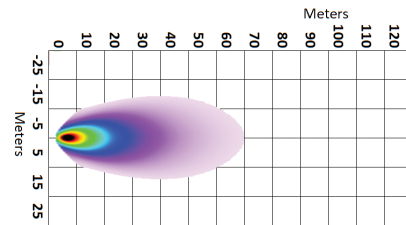

#### Medium

Intermediate distance and area spread for applications requiring more coverage than Spot, but higher illumination than Wide. Can be used on dozers and wheel loaders.

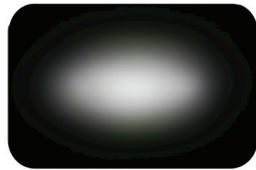

**Horizontal Elliptical**  
36° X 23°

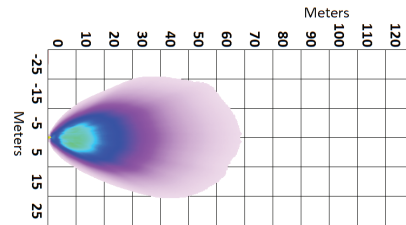

#### Horizontal Elliptical

Sharp horizontal cutoff for driving and operating applications requiring greater distance, minimized light pollution and wide-angle illumination. Use on haul trucks and other vehicles to limit distracting oncoming traffic. Effective for low-beam headlight applications.



**Vertical Elliptical**  
23° X 36°

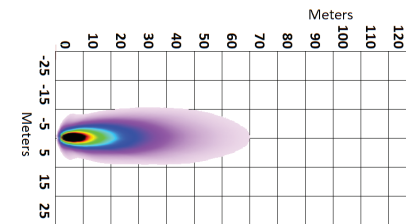

#### Vertical Elliptical

Sharp vertical cutoff for applications requiring large vertical coverage with limited horizontal light pollution and distraction. Illuminates tall surfaces without wasting light horizontally. Use on loaders to illuminate raised buckets while not distracting haul truck drivers.



**Wide**  
46°

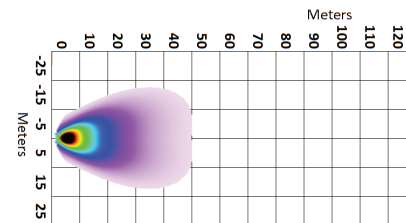

#### Wide Beam

Wide area flood pattern for illuminating large areas. Use on tracked and other slower-moving equipment. Great for general illumination around equipment perimeters, rear and decking.

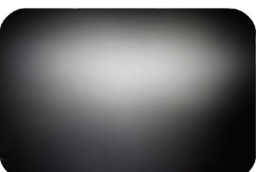

**Trapezoid**  
25° X 10°

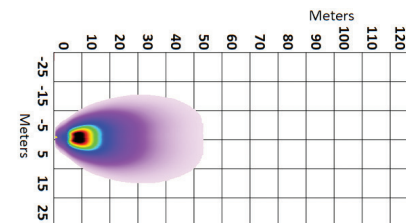

#### Trapezoid

For applications requiring automotive style headlight distribution to reduce glare from oncoming drivers while offering wide area lighting below horizon. Use on haul trucks and other vehicles commonly used in two-way traffic.

## HDI HEAVY DUTY ILLUMINATION LED EQUIPMENT LIGHTS

Making It Brighter, Easier And Safer To Work At Night

HDI LED equipment lights offer the brightness and durability required for the toughest jobs in utility, agriculture, construction, forestry, military and off-road applications.

- Energy-efficient, long-life LEDs (rated 50,000 hours)
- IP68 / IP69K – dust-tight / water-tight, plus withstands high-temperature/high-pressure water jets
- High shock and vibration resistance
- Reverse-voltage protection prevents damage to circuitry
- Rugged die-cast aluminum housing with black e-coat
- Wide operating temperature range
- Automotive optical grade, hard-coated polycarbonate lens
- Versatile hybrid (spot-wide) beam pattern
- Three (3) year warranty

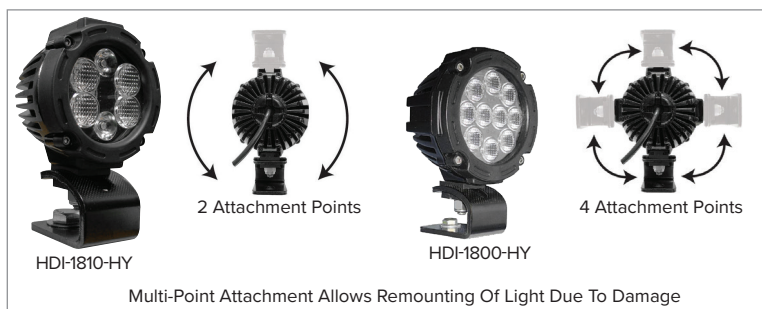

Part Number	HDI-1810-HY	HDI-1812-P-HY	HDI-136-HY-H	HDI-1800-HY	HDI-1812-3000-HY	HDI-1813-HY
-------------	-------------	---------------	--------------	-------------	------------------	-------------

Specifications						
Effective Lumens	1260	1380	1400	2500	3000	5000
Number of LEDs	6	6	6	10	6	22
Beam Pattern	Hybrid (Spot/Wide Beam)					
EMC Rated	EN 13309: 2010			EN 13309: 2010		
Shock/Vibration	5G RMS @ 10-500 Hz			5G RMS @ 10-500 Hz		
Ingress Protection	IP68 and IP69K		IP67	IP68 and IP69K		
Power	14 Watts	14 Watts	12 Watts	22 Watts	33 Watts	50 Watts
Current	1.2 A @ 12 VDC 0.6 A @ 24 VDC	1.2 A @ 12 VDC 0.18 A @ 76 VDC	1.0 A @ 12 VDC 0.5 A @ 24 VDC	1.8 A @ 12 VDC 0.9 A @ 24 VDC	2.75 A @ 12 VDC 1.38 A @ 24 VDC	4.2 A @ 12 VDC 2.2 A @ 24 VDC
Voltage	12-24 VDC	12-76 VDC	12-24 VDC	12-24 VDC	12-24 VDC	12-24 VDC
Operating Temp	-40°C - 60°C (-40°F - 140°F)					
Color Temp (CCT)	5700K Day White					
Weight	1.3 lbs (0.6 kg)	1.6 lbs (0.7 kg)	0.7 lbs (0.3 kg)	2.2 lbs (1.0 kg)	1.6 lbs (0.7 kg)	5.7 lbs (2.6 kg)
Dimensions	3.5 x 3.5 x 2.8 in.	3.9 x 3.9 x 2.5 in.	4.8 x 4.8 x 1.3 in.	4.6 x 4.6 x 2.6 in.	3.9 x 3.9 x 2.5 in.	6.0 x 5.5 x 3.0 in.
Mounting Hardware	Stainless Steel C-Bracket	Stainless Steel U-Bracket	Stainless Steel U-Bracket	Stainless Steel C-Bracket	Stainless Steel U-Bracket	Stainless Steel U-Bracket
Attachment Points	2			4		
Termination	6 in. Wire Leads	Deutsch Connector	6 in. Wire Leads	6 in. Wire Leads	Deutsch Connector	Deutsch Connector

# LIGHTING - EQUIPMENT LIGHTS

## JLITE LED EQUIPMENT LIGHTS

### Versatile Lighting For A Variety Of Applications

Durable housings, sealed construction and easy-mount brackets make Jameson JLite ideal for a wide variety of general-purpose lighting applications: Construction vehicles, utility trucks, forklifts, ATV's, golf carts, boats and more!

- IP65 – Protected against dust, dirt and low-pressure water jets
- Durable powder-coated die-cast aluminum housing
- Corrosion resistant stainless steel mounting bracket
- Impact resistant polycarbonate lens
- Various beam patterns
- 30,000 hours rated life
- CE and RoHS certifications
- One (1) year warranty



Part Number	JL33C5W	JL11800-FL	JL16C28W	JL13C48W	JL13C65W	JL9C90S	JL9C90W
-------------	---------	------------	----------	----------	----------	---------	---------

Specifications							
Effective Lumens	500	1800	2520	2700	5460	6750	
Number of LEDs	33	8	16	13	13	9	
Beam Patterns	Wide	Flood	Wide	Wide	Wide	Spot	Wide
Ingress Protection	IP65						
Power	5 Watts	18 Watts	28 Watts	30 Watts	65 Watts	90 Watts	
Current	0.4 A @ 12 VDC 0.2 A @ 24 VDC	1.4 A @ 12 VDC 0.7 A @ 24 VDC	2.3 A @ 12 VDC 1.2 A @ 24 VDC	2.5 A @ 12 VDC 1.3 A @ 24 VDC	5.4 A @ 12 VDC 2.7 A @ 24 VDC	6.3 A @ 12 VDC 3.2 A @ 24 VDC	
Voltage	10-30 VDC	12-24 VDC	10-30 VDC				
Operating Temp	-20°C - 50°C (-4°F - 122°F)						
Color Temp (CCT)	6000K Cool White						
Weight	0.2 lbs (0.1 kg)	1.4 lbs (0.6 kg)	0.7 lbs (0.3 kg)	1.1 lbs (0.5 kg)	2.7 lbs (1.2 kg)	6.4 lbs (2.9 kg)	
Dimensions	3.7 x 3.0 x .91 in.	5.6 x 4.0 x 2.3 in.	5.5 x 4.3 x 1.9 in.	5.7 x 4.9 x 2.8 in.	6.5 x 5.6 x 3.7 in.	6.3 x 5.3 x 4.7 in.	
Termination	6 in. Wire Lead with Deutsch Connector (Mating Connector Included)						

### WIRING HARNESSES SOLD SEPARATELY

Part Number	Description
JLWH-DT1	14 ft. Wiring Harness With On/Off Switch & One Deutsch Connector, Battery Ring Terminals
JLWH-DT2	14 ft. Wiring Harness With On/Off Switch & Two Deutsch Connectors, Battery Ring Terminals

JLWH-DT1-CIG	12 ft. Wiring Harness, One Deutsch Connector & 12V Auto Plug Adapter, 10A Fuse
JLWH-DT2-CG	12 ft. Wiring Harness, Two Deutsch Connectors & 12V Auto Plug Adapter, 10A Fuse



## BACK UP ALARMS

### Protection For All Work Environments Day or Night

Back Up Alarms provide essential notification alerting the presence of nearby work vehicles. Vehicles equipped with Back-Up Alarms help reduce liability and create a safer work environment around the clock.

#### Applications include:

- Service/Fleet Vehicles
- Utility Trucks
- Delivery Trucks
- Tractor-Trailers
- Construction Vehicles
- Fork-Lifts
- Heavy Equipment

#### BACK-UP ALARM

Part Number	BA-151008
Lumens	N/A
Operating Voltage	12-24 VDC
Temperature Range	-30°C - 55°C (-22°F - 131°F)
Ingress Protection	IP68 / IP69K
SAE/DOT Noise Compliant	SAE J994
Weight	0.5 lbs (0.2 kg)
Dimensions	3.3 x 2.7 x 1.6 in.
Housing	Glass Filled Nylon
Mounting	Horizontal or Vertical
Lens	N/A
Connection	Terminal Studs
<b>SAE/DOT Noise Compliant: Meets SAE J994</b>	



**BA-151008**

- Loud 97dB audible alarm
- Reverse polarity voltage protection
- Corrosion-resistant design for heavy-duty applications
- Epoxy encapsulated - protected against dust, water and vibration

#### LED STROBE BACK-UP ALARM

Part Number	BA-152051
Lumens	200
Operating Voltage	12-24 VDC
Temperature Range	-40°C - 85°C (-40°F - 185°F)
Ingress Protection	IP68 / IP69K
SAE/DOT Noise Compliant	SAE J994
Weight	0.4 lbs (0.2 kg)
Dimensions	3.2 x 4.0 x 1.7 in.
Housing	ABS Plastic
Mounting	Horizontal or Vertical
Lens	Optical Grade Acrylic
Connection	Wire Leads
<b>SAE/DOT Noise Compliant: Meets SAE J994</b>	



**BA-152051**

- Loud 97dB audible alarm
- Bright 200 lumen flashing amber LEDs
- High-visibility wrap-around lens for >180° field-of-view
- Multi-function operation, including Night-Silent for use in sound sensitive areas
- Corrosion-resistant design for heavy-duty applications
- Epoxy encapsulated - protected against dust, water and vibration

## ML MARKER LIGHTS

### High Visibility Brake Lights & Tail Lights For Extreme Environments

Our ML Marker Lights penetrate thick layers of dust or mud buildup, fog, snow and rain to provide high visibility of heavy equipment or vehicles.

Featuring the same robust protection and reliable circuits as the XD lights, ML Marker Lights are fully encapsulated for waterproofing and feature a hardened borosilicate lens.

- Type III Anodized Chassis for corrosion resistance
- Fully Encapsulated PCB prevents ingress of dust and water
- Low Power Consumption
- Thermal Management prolongs life and boosts output
- Reverse Polarity
- Wide Voltage Input Range
- Dimmable feature allows use as turn signal or brake light

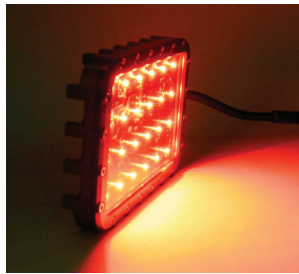
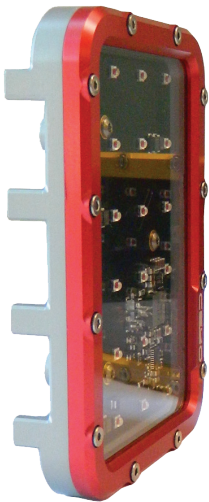

ML24-R-SM

#### RED LEDS

Part Number	ML24-R-SM
LED Options	<b>DOT Red</b>
Max Power	8-20 Watts
Operating Voltage	10-32 VDC
Raw Lumens	1,340
Effective Lumens	1,206
Current @28VDC	<700mA
Ingress Protection	IP69K
Lifetime (hrs)	50,000
Weight	1.2 lbs

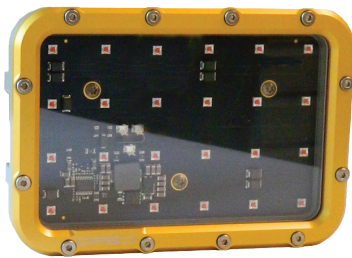

ML24-A-SM

#### AMBER LEDS

Part Number	ML24-A-SM
LED Options	<b>DOT Amber</b>
Max Power	8-20 Watts
Operating Voltage	10-32 VDC
Raw Lumens	1,340
Effective Lumens	1,206
Current @28VDC	<700mA
Ingress Protection	IP69K
Lifetime (hrs)	50,000
Weight	1.2 lbs

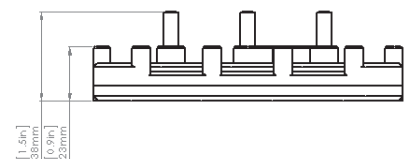
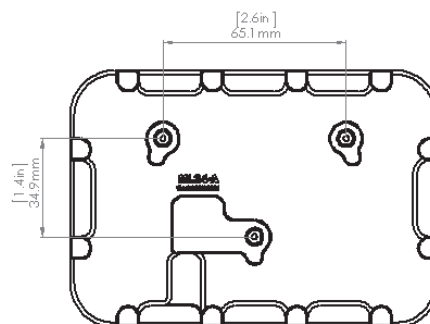
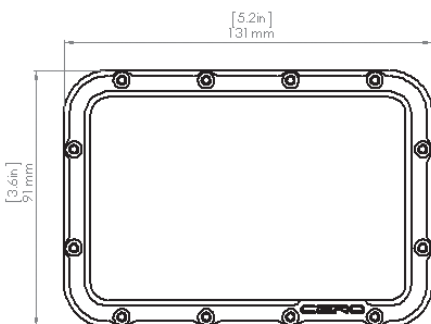

## VEGA™ PORTABLE RECHARGEABLE LED LIGHT High Intensity Lighting

Designed for tough conditions, and offering rugged construction and high performance, the LED floodlight was designed to go wherever the job takes you. Lightweight and battery-powered with an integrated carrying handle for maximum portability.

### Features:

- 21 High-Performance LEDs
- IP65 Waterjet Resistant
- 8-Hour Battery Life\*
- Shock and Vibration Resistant
- Integrated Battery Meter
- Dimming Capability
- Switch For Instant Maximum Optical Output
- Charger Included
- Diffuse Lens Changes Spot Optic To Flood (Optional)
- 5-Year Limited Warranty

### Applications:

- Construction Sites
- Roadside Service
- Rail yards
- Emergency Repairs
- Expeditionary/FOBs
- Disaster Cleanup
- First Responders
- Security
- Recreation
- Fire & Rescue



Part Number	Description
31-PBL21-S	LED Spotlight, 20° Beam Angle
31-PBL21-W	LED Wide Angle, 76° Beam Angle
31-PBL-TRI	10 ft. Tripod & Mounting Plate (Light Sold Separately)
31-DLW	Diffuse Lens, 76° Beam Angle
31-PBL-MAG1	Magnetic Base (Light Sold Separately)

Specifications	
Lumens	16,670
*Run Time	*8 Hours At 80% Output
Battery Type	Rechargeable Lithium Ion
Operating/Storage Temp	-20°C - 60°C (-4°F - 140°F)
Charging Temp	5°C - 45°C (41°F - 113°F)
Dimensions	13.3 x 12.7 x 6.8 in. 337.8 x 322.6 x 172.7 mm
Weight	19 lbs



Military grade venting system prevents internal condensation that can fog light. This feature is critical for high humidity applications.

Toggle For Instant Maximum Optical Output

On/Off

Dimming Knob

Battery Level Meter



Diffuse Lens (optional)



Charger (included)



Magnetic Base

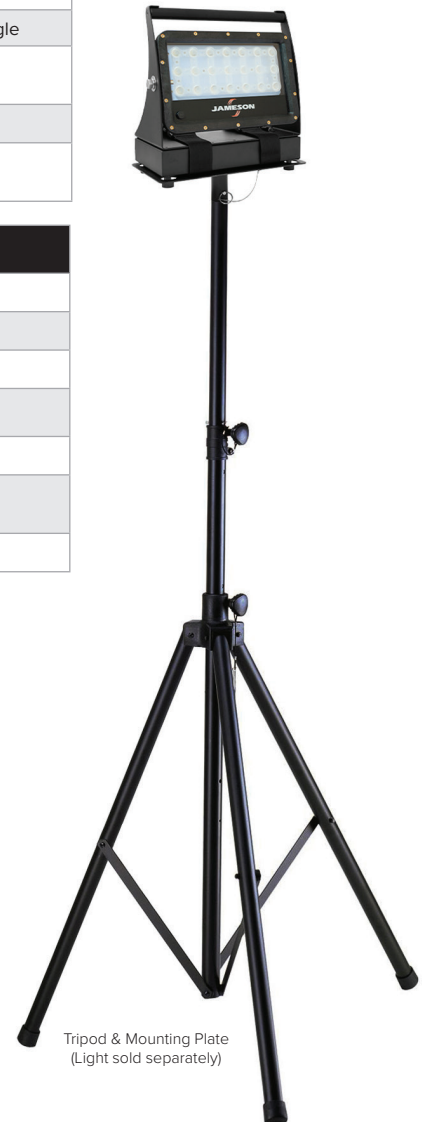

Tripod & Mounting Plate (Light sold separately)



## WIDE AREA LIGHTS

### Wide Area Light On Adjustable Tripod

Our Tripod Light offers intense, adjustable lighting. The 3 light heads have 360° tilt and rotation to provide lighting for a variety of applications. The adjustable tripod folds to a compact 59" height for convenient storage.

#### Light Head Features:

- Energy-efficient, long-life LEDs (rated 50,000 hours)
- IP68 / IP69K – dust-tight / water-tight, plus withstands high-temperature/high-pressure water jets
- High shock and vibration resistance
- Reverse-voltage protection prevents damage to circuitry
- Rugged die-cast aluminum housing with black e-coat
- Wide operating temperature range
- Automotive optical grade, hard-coated polycarbonate lens
- Versatile hybrid (spot-wide) beam pattern

Part Number	Description
31-WA-1812-3000-TR	Wide Area LED Light with Tripod

Specifications - Lights	
Power	100 Watts
Input Voltage	90-264 VAC
Effective Lumens	9,000
Weight Per Light Head	1.6 lbs each
Operating Temperature	-40°C - 60°C (-40°F - 140°F)
Input Cable	1 (Power In)
Output Cables	3 (One Per Light)
Individual Light Head Dimensions	3.9 x 3.9 x 2.5 in. (99.0 x 99.0 x 63.5 mm)
Input Cable Length	50 ft.
Plug	NEMA 5-15

Specifications - Tripod	
Height	5 ft. - 10 ft. (Collapsed-Extended)
Base Wide	13.0 - 58.0 in. (Collapsed-Extended)
Material	Aluminum, Powder Coated
Bar Mount	Quick Release Pin - Removable for Storage
Folded Dimensions	59.0 x 13.0 x 13.0 in. 1498.6 x 330.2 x 330.2 mm
Tripod Light Without Case	34.0 lbs
Light and Case Weight	82.0 lbs
Transport Case	66.5 x 22.0 x 12.5 in. 1689.1 x 558.8 x 317.5 mm

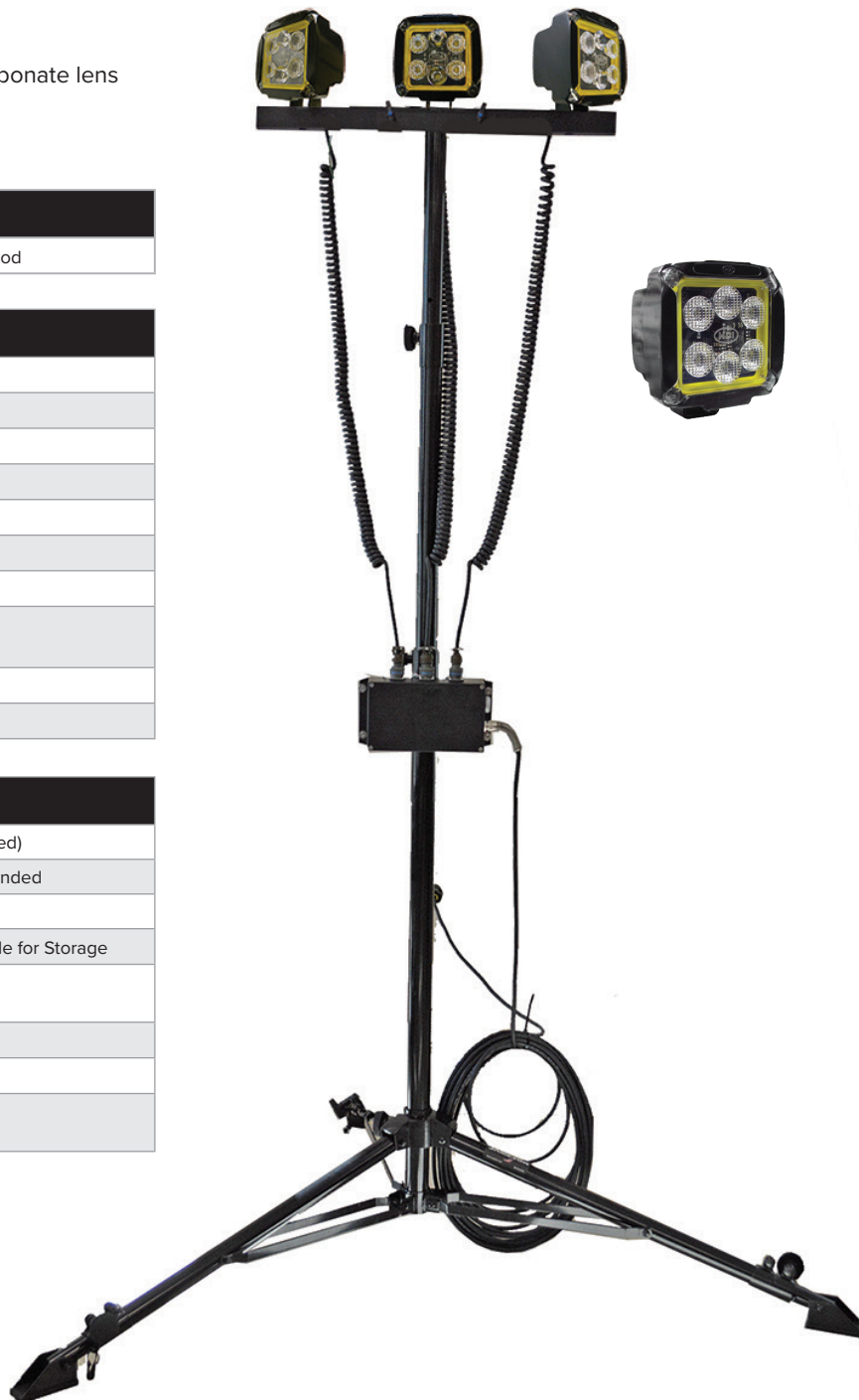

## HIGH BAY LIGHTS

### Large Area Lighting For Temporary Structures

- Aircraft & Vehicle Maintenance Shelters
- Large & Medium Area Maintenance Shelters
- Morale, Welfare & Recreation Shelters
- Billeting & Dining Halls
- Vehicle Wash Bays
- Clear Span Structures
- Inflatable Beam Shelters
- Outdoor Low Mast & Security

#### Features:

- High Efficiency, Long-Lasting LED Light Sources
- Instant Start (No Warm-Up Period)
- Surface Temperature Remains Safe For Handling
- LEDs Provide Efficient Directional Light That Require No Reflectors Like Metal Halide Lights
- Rugged, Durable Construction Withstands Repeated Installations And Take-Downs
- Sealed Components Survive High-Moisture Environments And Extreme Temperature Conditions
- No Maintenance, Surge Protected
- Simple Installation – Mounts To Framework Or Suspended By Hanging Cable
- Safety Cable Prevents Accidental Drops During Installation
- Pivot Bracket For Convenient Aiming/Leveling
- UL Recognized Components



Part Number	Description
31-HB4	LED High Bay Light, 4 Module
31-HB6	LED High Bay Light, 6 Module
31-HB-SC	Safety Cable For High Bay Light
31-HB-HC	Hanging Cable For High Bay Light

Specifications	31-HB4	31-HB6
Power	200 Watts	300 Watts
Input Voltage	90-305 VAC	
Actual Lumens	33,000	49,500
Beam Angle	90°	
CRI	>75	
Color Temperature	4800 K	
Number of LEDs	112	168
LED Rated Life (L70)	50,000 hours	
Dimensions	14.0 x 12.0 x 7.0 in.	20.7 x 12.0 x 7.0 in.
Weight	13.5 lbs	18.5 lbs
Ingress Protection	IP67	
Cable	14/3 SOOW, 6 ft. or custom lengths	
Connector	NEMA 5-15 standard (others available by request)	



31-HB4



31-HB6



WHEREVER THE JOB TAKES YOU,  
**COUNT ON JAMESON™**



**JAMESONTOOLS.COM**

800.346.1956

PD\_2022-33  
REV10/2022