

## Features:

- Intergrated over temperature protection fuse
- Module case ultrasonically sealed to reduce dimmer buzzing
- Fits a plaster depth (16mm) mounting box
- One or two way switching
- Complies with the latest Electrical Safety Standard for dimmer switches EN60669-2-1:2000
- EMC Compliance - EN550155
- Suitable for use with 1-10V LED Drivers
- Smooth dimming operation from 0-100%

## Models

### EcoDim-1-10V

## Specifications

Input Voltage Type	DC
Input Voltage (Max)	10V
Input Voltage (Min)	1V
Size	62.2 x 26 x 46.2 mm

## Important User Information

- EcoDim dimmer switches comply with the latest European Safety and EMC Regulations
- Safety Compliance - EN 60669-2-1:2000
- EMC Compliance - EN 50015
- Module only- Faceplate not included

## Important Installation Information

### Always switch off mains supply before installation or maintenance works.

1. Fit the dimmer module to the required plate.
2. Install the mounting box in the required position.
3. A 3-core cable is required between the switch and the control gear (LED Driver or Ballast). Connect two wires from the 1-10V Dimmer terminal of the control gear to the + and- terminals of the dimmer switch. Connect a live feed to the common of the dimmer switch and connect from L1 to the Live input of the control gear. See diagram overleaf.
4. To connect the dimmer switch for 1 or 2-way switching, please refer to the diagram overleaf.
5. When stripping the cables for wiring ensure that no bare conductors can project from the terminals.
6. Dimmer switches with a metal front plate **MUST** be earthed using the Earth terminal or Earth fly lead on the front plate.
7. After connecting the wiring push the dimmer switch back towards the wall box ensuring the that the wiring is not trapped between the back of the dimmer module and the mounting box or the front plate and the mounting box, tighten the plate fixing screws provided. Do not overtighten the fixing screws or you may distort or break the front plate.
8. When installation is complete switch on the mains supply and push the dimmer knob to operate. Adjust the rotary knob until the desired light level is reached.

**Please note** - DO NOT perform insulation resistance tests on a lighting circuit with a dimmer switch connected. An insulation resistance test may damage the electronic components in the dimmer beyond repair. A slight buzzing noise may be heard from the dimmer switch in operation, this is perfectly normal.

## Connecting Diagram

EcoDim dimmer switches are suitable for 1 or 2-way lighting circuits.

The dimmer has a push-on, push-off switch action and a rotary action to dim the light.

Each 1-10V dimmer module has 5 screw terminals, L1, L2, C (common) and the 1-10V connections marked + and -

### 1-Way Switching

- In 1-way lighting circuits each light is controlled by 1 switch
- Connect the two wires either way round, to the C terminal and either L1 or L2. One of the L terminals is not used in 1-way switching.

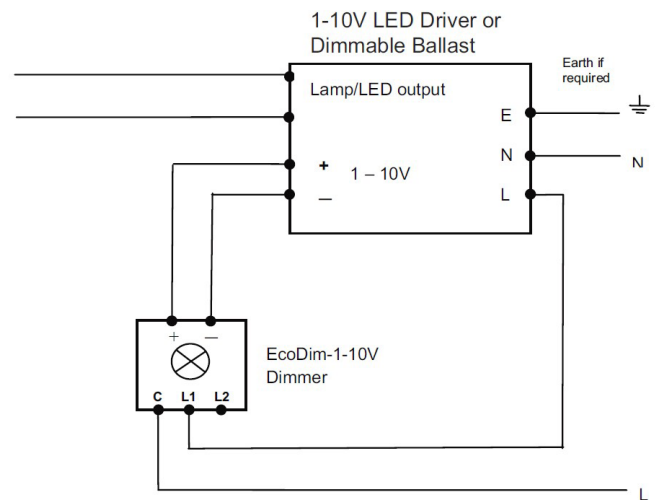

### 2-Way Switching

- 2-Way lighting circuits have two switches controlling the same lights from two different locations.
- This arrangement is commonly used at the top and bottom of staircases or at the entry and exit doors to a room.
- One standard plate switch is used with the dimmer switch for 2-way switching applications. See below for a typical 2-way circuit.

