

MCT 325 L16

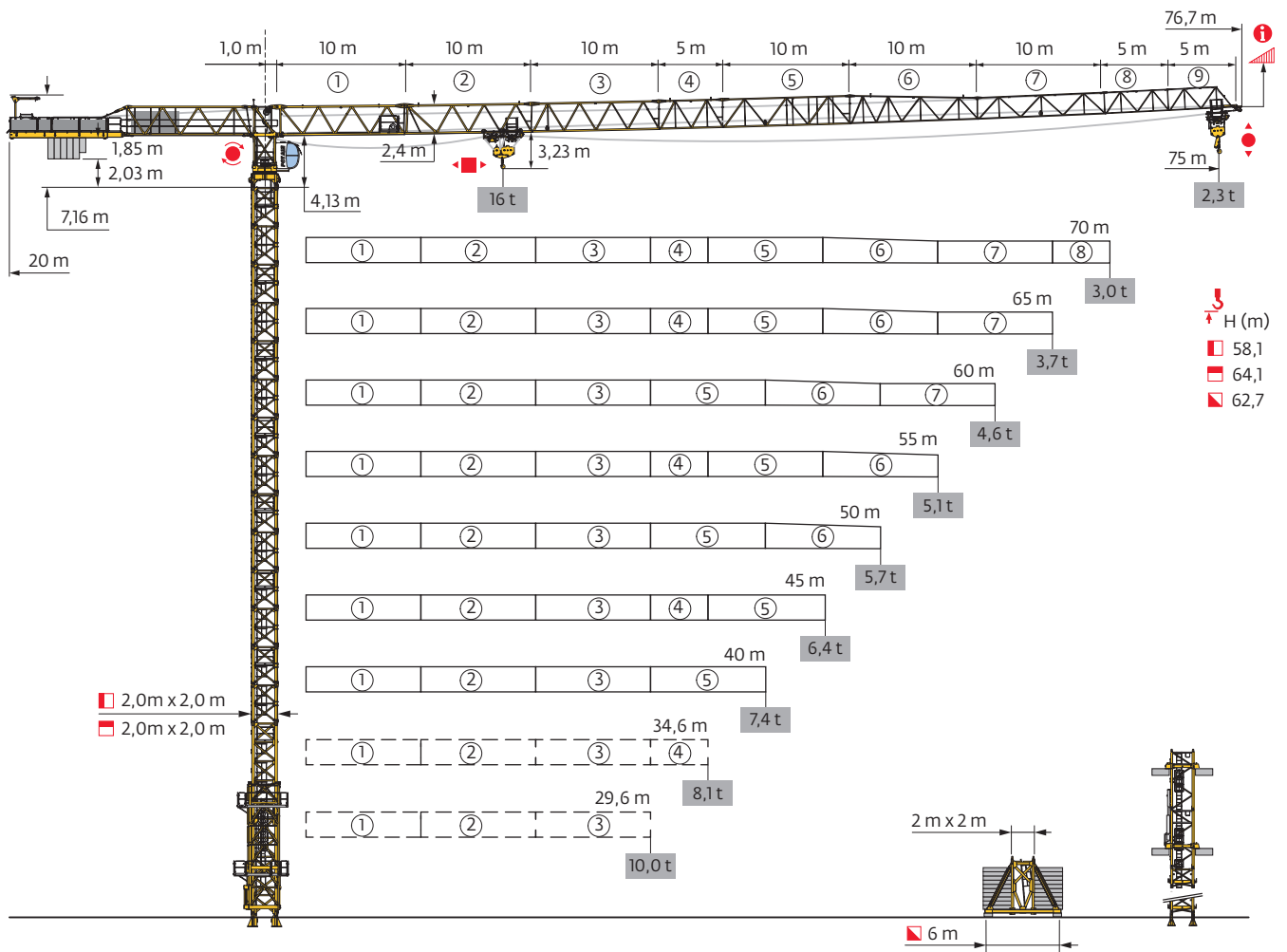

Power Control

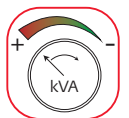

Mât - Réactions / Mast - Reaktionskräfte / Mast - Reactions / Mástil - Reacciones / Torre - Reazioni
 Tramo - Reações / Реакция опор мачты

▣ 2,0 m - P 21A

▴ (m)	30	35	40	45	50	55	60	65	70	75
▾ (m)	55,1	55,1	55,1	55,1	55,1	55,1	55,1	58,1	58,1	58,1
3,0 m	13	13	13	13	13	13	13	14	14	14
7,5 m	2	2	2	2	2	2	2	2	2	2
F2 (t)	● 153	● 152	● 153	● 154	● 153	● 155	● 155	● 168	● 169	● 173
F3 (t)	■ 170	■ 171	■ 175	■ 177	■ 176	■ 177	■ 177	■ 199	■ 204	■ 212
	● 107	● 105	● 105	● 105	● 103	● 103	● 102	● 113	● 114	● 118
	■ 132	■ 132	■ 135	■ 136	■ 134	■ 133	■ 133	■ 152	■ 156	■ 165

▣ 2,0 m - P 21BR

▴ (m)	30	35	40	45	50	55	60	65	70	75
▾ (m)	64,1	64,1	64,1	64,1	64,1	64,1	64,1	64,1	61,1	61,1
3,0 m	16	16	16	16	16	16	16	16	15	15
7,5 m	2	2	2	2	2	2	2	2	2	2
F2 (t)	● 183	● 183	● 181	● 182	● 181	● 185	● 186	● 194	● 186	● 190
F3 (t)	■ 267	■ 269	■ 273	■ 275	■ 274	■ 275	■ 276	■ 276	■ 256	■ 265
	● 130	● 129	● 127	● 126	● 125	● 126	● 127	● 133	● 126	● 130
	■ 223	■ 224	■ 226	■ 228	■ 225	■ 225	■ 224	■ 224	■ 204	■ 212

▣ 2,0 m - VB 21A

▴ (m)	30	35	40	45	50	55	60	65	70	75
▾ (m)	59,7	59,7	59,7	59,7	59,7	56,7	56,7	59,7	62,7	59,7
3,0 m	13	13	13	13	13	12	12	13	14	13
7,5 m	2	2	2	2	2	2	2	2	2	2
F1 (t)	● 99	● 99	● 99	● 100	● 100	● 99	● 99	● 105	● 111	● 107
	■ 118	■ 119	■ 121	■ 122	■ 120	■ 108	■ 108	■ 121	■ 138	■ 129

▣ 2,0 m - BA 66A

▴ (m)	30	35	40	45	50	55	60	65	70	75
▾ (m)	47,4	47,4	44,4	44,4	44,4	44,4	44,4	41,4	41,4	41,4
3 m	14	14	13	13	13	13	13	12	12	12
3 m (L68C)	1	1	1	1	1	1	1	1	1	1
1,5 m (L68C)	1	1	1	1	1	1	1	1	1	1

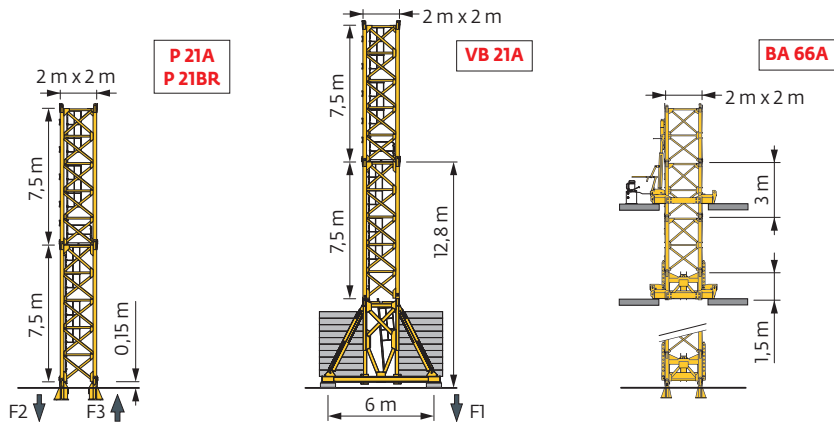

Télescopage sur dalles / Kletterkrane im Gebäude / Climbing Crane / Telescopage grua trepadora / Gru in cavedio
 Telescopagem sobre lajes / Кран, ползущий внутри здания

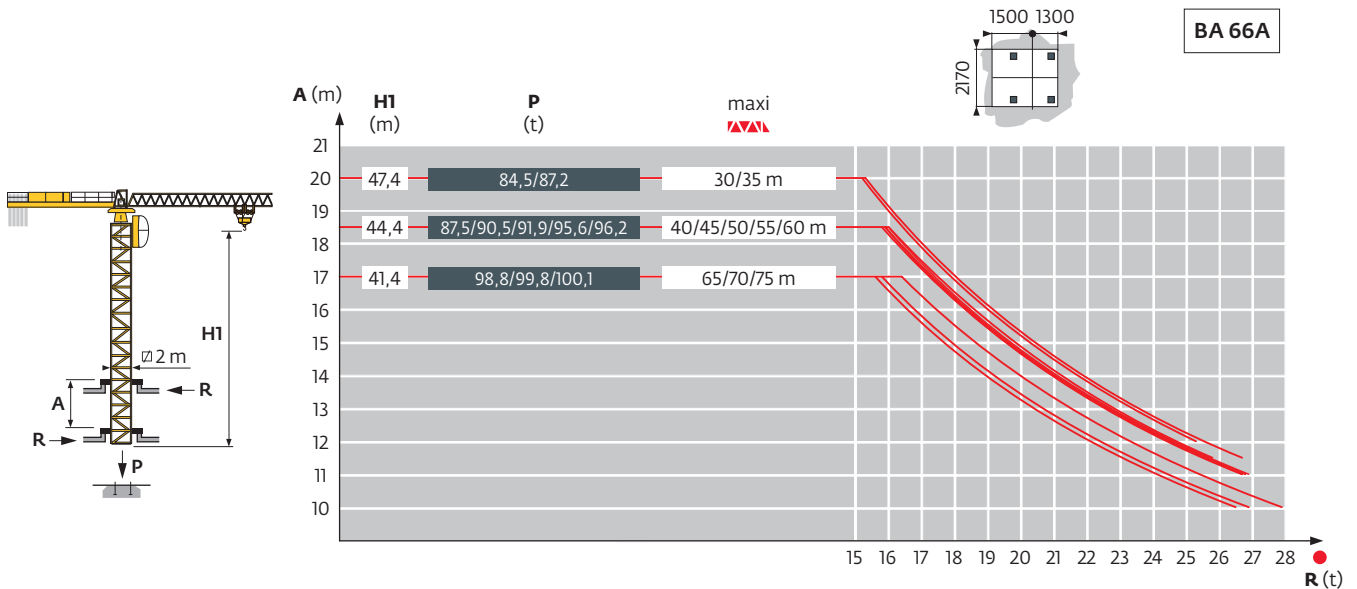

Ancrages / Verankerungen / Anchorages / Anclajes / Ancoraggi
 Ancoragem / Анкера

P 21A AL 601A

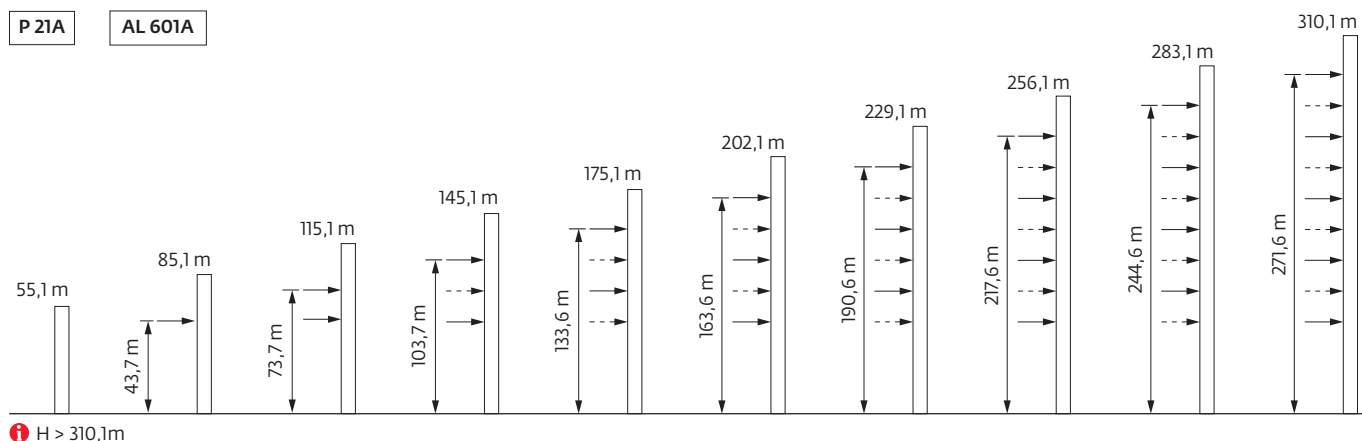

P 21BR AL 601A

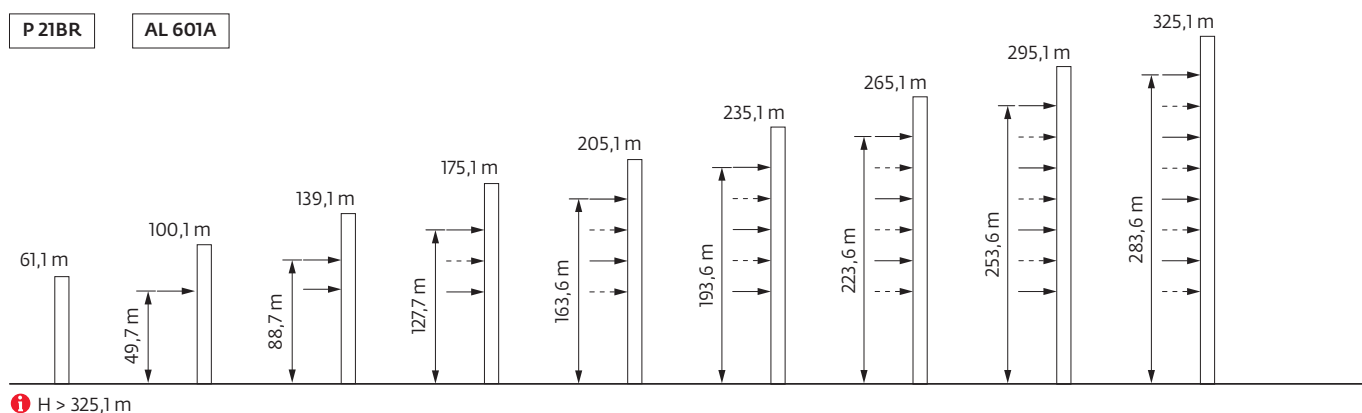

Courbes de charges / Lastkurven / Load curves / Curvas de cargas / Curve di carico
 Curvas de carga / Кривые нагрузок



	▼▲▲▲▲ (m)		12	15	17	20	22	25	27	29,6	30	32	34,6	35	37	40	42	45	47	50	52	55	57	60	62	65	67	70	72	75	m
▼▲▲▲▲	▲▲▲▲▲	▲▲▲▲▲	▲▲▲▲▲										▲▲▲▲▲																		
75	3,1 → 14,8	26,0 - 28,3	16	15,7	13,5	11,1	9,9	8,4	8	-	7,5	6,9	-	6,2	5,8	5,3	5	4,6	4,3	4	3,8	3,5	3,4	3,1	3	2,8	2,7	2,55	2,45	2,3	t
70	3,1 → 16,5	29,2 - 31,6	16	16	15,4	12,7	11,3	9,7	8,8	-	8	7,9	-	7,1	6,6	6,1	5,7	5,3	5	4,6	4,4	4,1	3,9	3,7	3,5	3,3	3,2	3,0			t
65	3,1 → 17,8	31,7 - 34,3	16	16	16	14	12,5	10,7	9,8	-	8,6	8	-	7,8	7,3	6,7	6,3	5,8	5,5	5,1	4,9	4,6	4,4	4,1	3,9	3,7				t	
60	3,1 → 19,5	34,8 - 37,6	16	16	16	15,5	13,9	12	10,9	-	9,6	8,9	-	8	8	7,4	7	6,5	6,2	5,7	5,5	5,1	4,9	4,6						t	
55	3,1 → 19,5	34,7 - 37,5	16	16	16	15,5	13,9	11,9	10,9	-	9,6	8,9	-	8	8	7,4	7	6,5	6,2	5,7	5,5	5,1								t	
50	3,1 → 19,4	34,7 - 37,4	16	16	16	15,5	13,8	11,9	10,8	-	9,6	8,8	-	8	8	7,4	7	6,5	6,1	5,7										t	
45	3,1 → 19,3	34,4 - 37,1	16	16	16	15,3	13,7	11,8	10,8	-	9,5	8,7	-	8	8	7,3	6,9	6,4													t
40	3,1 → 19,4	34,6 - 37,4	16	16	16	15,5	13,8	11,9	10,8	-	9,5	8,8	-	8	8	7,4															t
35	3,1 → 19,6	-	16	16	16	15,6	14	12	11	-	9,7	8,9	8,1																		t
30	3,1 → 19,8	-	16	16	16	15,8	14,2	12,2	11,1	10																					t

▲▲▲▲▲ = ▲▲▲▲▲ - 0,81 t max

Lest de base / Grundballast / Base ballast / Lastre de base / Zavorra di base
 Lastro da base / Базовый Балласт

⚖️ (t) / 📏 2 m - VB 21A - 🚧										
📏 (m)	30	35	40	45	50	55	60	65	70	75
62,7	-	-	-	-	-	-	-	-	132	-
59,7	120	120	120	120	120	-	-	120	120	120
56,7	96	108	108	108	108	120	120	120	120	120
53,7	96	96	108	108	108	108	108	120	120	120
50,7	96	96	108	108	108	108	108	108	108	120
47,7	96	96	96	108	108	108	108	108	108	108
44,7	96	96	96	96	96	108	108	108	108	108
41,7	84	96	96	96	96	96	96	108	108	108
38,7	84	96	96	96	96	96	96	96	96	96
35,7	84	84	84	96	96	96	96	96	96	96
32,7	84	84	84	84	84	96	96	96	96	96
29,7	84	84	84	84	84	84	84	96	96	96
26,6	84	84	84	84	84	84	84	84	84	84
23,6	72	84	84	84	84	84	84	84	84	84

Poids de flèche & lest de contre-flèche / Auslegergewicht & Gegenauslegerballast / Jib weight & counter-jib ballast / Peso de flecha y lastre de contra-flecha / Peso del braccio & zavorra di contro-braccio / Peso da lança & lastro da contra lança
 Вес стрелы и балласт контр-стрелы

📏 (m)	75 LVFC; 75/90 HPL™ 📏				100 LVF 📏			
	4600 kg	4000 kg	2200 kg	⚖️ (kg)	4600 kg	4000 kg	2200 kg	⚖️ (kg)
75 m	5	0	1	25200	4	1	1	24600
70 m	5	0	1	25200	4	1	1	24600
65 m	4	1	1	24600	3	2	1	24000
60 m	3	2	0	21800	4	0	1	20600
55 m	2	3	0	21200	3	1	1	20000
50 m	4	0	0	18400	2	2	0	17200
45 m	3	1	0	17800	3	0	1	16000
40 m	2	1	1	15400	3	0	0	13800
35 m	3	0	0	13800	1	2	0	12600
30 m	0	3	0	12000	1	1	1	10800

CCV 4600 kg

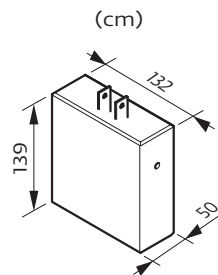
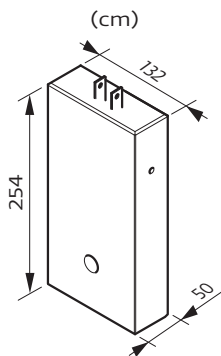
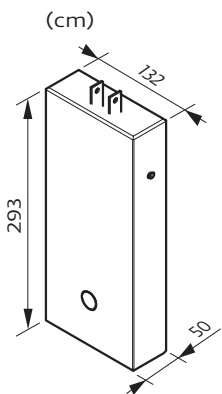

CCW 4000 kg

CCX 2200 kg









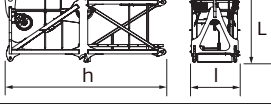
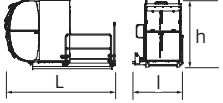
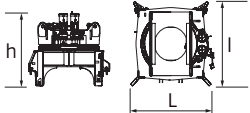
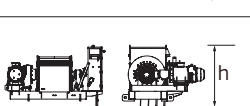
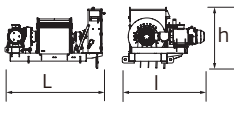
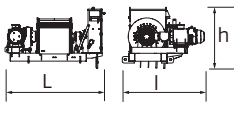
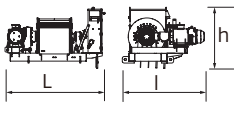
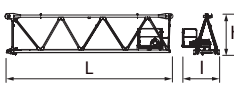
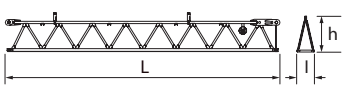
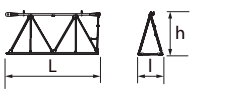
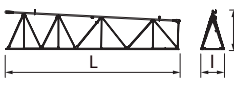
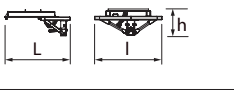
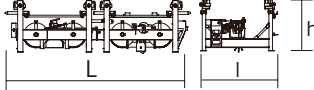

Encombremet et poids / Abmessungen und Gewicht / Dimensions and weight / Dimensiones y peso / Ingombro e peso
dimensões e pesos / габаритные размеры и вес

Partie tournante / Drehender Kranteil / Slewing crane part / Parte giratoria

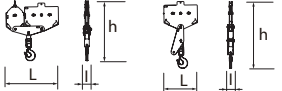
Parte rotante / Parte rotativa / Поворотная часть :  75 m -  -  75 LVFC; 75/90 HPL™

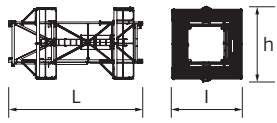
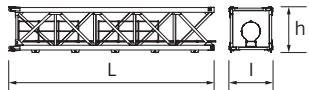
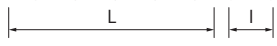
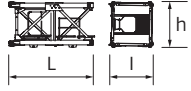

Partie tournante / Drehender Kranteil / Slewing crane part Parte giratoria / Parte rotante / Parte rotativa Поворотная часть		L (m)	l (m)	h (m)	kg (+/-5%)	
Contre-flèche / Gegenausleger Counter-jib / Contra-flecha Controbraccio / Contra-lança Контр-стрела		10,26	1,35	2,42	2685	
		9,12	4,09	1,7	3944	
Porte-flèche / Auslegerträger Cathead / Porta-flecha Cuspide / Suporte de lança Оголовок		2,32	1,52	4,8	2915	
cabine / Kabine cab / cabina cabina / cabina кабина		V140S	3,9	1,95	2,47	1115
Pivot / Krankopf Towerhead / Pivote Portaralla / Pivot Секция поворотной части		L68	2,45	2,48	2,15	5800
		L69	2,45	2,48	2,15	5940
Treuril de levage (+ câble) / Hubwerk (+ Seil) Hoisting winch (+ rope) / Mecanismo de elevación (+ cabo) Argano di sollevamento (+ fune) Guincho de elevação (+ cabo) Подъемная лебедка (+ канатом)		75 LVFC	2,68	1,63	1,65	2020
		75/90 HPL™	2,82	1,32	1,71	2785
		100 LVF	3,09	1,60	1,88	4505
Elément de flèche / Auslegerelement Jib section / Elemento de flecha Elemento di braccio / Elemento de lança Секция стрелы		①	10	2,21	2,53	4180
		②	10	1,38	2,44	2800
③		10	1,38	2,35	2230	
⑤		10	1,38	2,30	1498	
⑦		10	1,38	1,75	853	
Elément de flèche / Auslegerelement Jib section / Elemento de flecha Elemento di braccio / Elemento de lança Секция стрелы		④	5	1,38	2,41	855
		⑧	5	1,38	1,70	303
		⑨	5	1,38	1,69	266
Elément de flèche / Auslegerelement Jib section / Elemento de flecha Elemento di braccio / Elemento de lança Секция стрелы		⑥	10	1,38	2,26	1024
			40 m - 75 m	1,52	1,57	0,61
30 m - 35 m	1,52		1,57	0,61	179	
Chariot / Laufkatze Trolley / Carrello Carro / Carro-distribuidor Тележка		 16 t	3,26	1,74	1,05	553
		 8 t	1,76	1,74	1,05	290
Moufle / Hubflasche Pulley block / Aparejo Bozzello / Cadernal Полиспаст		 16 t	1,65	0,26	1,80	478
		 8 t	1,09	0,26	2,11	280

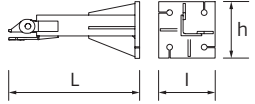
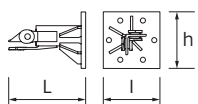
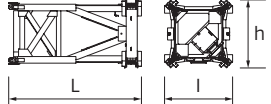
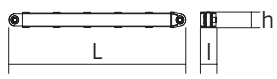
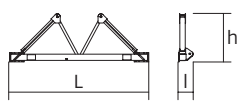
Équipement de télescopage / Teleskopierausrüstung / Telescoping equipment Equipo de telescopaje / Equipaggiamento di telescopaggio / Equipamento de telescopagem Оборудование для телескопирования	L (m)	l (m)	h (m)	kg (+/- 5%)		
Cage de télescopage / Teleskopwagen Telescopic cage / Jaula de telescopaje Gabbia di telescopaggio / Gaiola de telescopagem для телескопирования крана		√2 m	7,26	3,78	3,98	5195
Mâture / Mastwerk / Masts Mástil / Torre / Coluna Мачты						
S 68 J SR 68 J		7,74 7,74	2,1 2,1	2,1 2,1	4170 5175	
S 69 J S 69 JR		7,81 7,81	2,12 2,12	2,12 2,12	4768 4786	
L 68 B3 L 69 B2		3,26	2,12	2,12	1530	
		3,31	2,12	2,12	1860	
Bases / Kranbasen / Crane bases Bases / Basi / Bases фундамент под кран						
Pieds de scellement / VerankerungsfüÙe Fixing angles / Pie de empotramiento Montante da annegare / Angulos fixadores анкера		P 21A P 21BR	1,31 1,30	0,8 0,8	0,8 0,8	500 417
		R 21A R 21BR	0,8 0,8	0,6 0,6	0,6 0,6	200 222
Mât-châssis / Grundmasteinheit Basic mast unit / Tramo-chasis Elemento base / Tramo-chassis Мачта для крепления к шасси		VB 21A	5,01	2,41	2,41	4390
Haubans / Mastabstützungen Struts / Tornapuntas Puntoni / Escoras Растяжка		VB 21A	4,51	0,29	0,29	420
Sommier / Unterwagenhälfte Half-bearer / Testero Testata / Estrutura base Траверса		VB 21A	6,7	0,7	2,31	1600

Mécanismes / Triebwerke / Mechanisms / Mecanismos / Meccanismi
Mecanismos / Механизмы

400 V - 50 Hz													ch - PS hp	kW	
	75 LVFC 40 Optima	m/min	34	44	62	90	17	22	31	45	75	55	637 m		
		t	8	6	4	2	16	12	8	4					
	75 HPL™ 40	m/min	33,5	43,5	63	110	167	17,5	23	33	59,5	83,5	75	55	539 m
		t	8	6	4	2	0,6	16	12	8	4	1,8			
	100 LVF 40 Optima	m/min	44,5	57	76	99	116,5	23	30	40	52	58,5	100	75	1136 m
		t	8	6	4	2	0,84	16	12	8	3,5	2,74			
	RVF 162 Optima+	tr/min U/min -rpm	0 → 0,7									2 x 7,5	2 x 5,5		
	6 DVFC 6	m/min	0 → 42 (16 t) 0 → 84 (8 t) 0 → 100 (4 t)									5,5	4,0		

IEC 60204-32	
400 V (+10% -10%) 50 Hz	75 LVFC : 78 kVA 75 HPL™ : 78 → 48 kVA 100 LVF : 98 kVA

480 V - 60 Hz													ch - PS hp	kW	
	75 LVFC 40 Optima	m/min	34	44	62	90	17	22	31	45	75	55	637 m		
		t	8	6	4	2	16	12	8	4					
	90 HPL™ 40	m/min	40	52,5	75	132	167	21	27	39,5	71,5	83,5	90	66	539 m
		t	8	6	4	2	1,4	16	12	8	4	3,3			
	100 LVF 40 Optima	m/min	44,5	57	76	99	116,5	23	30	40	52	58,5	100	75	1136 m
		t	8	6	4	2	0,84	16	12	8	3,5	2,74			
	RVF 162 Optima+	tr/min U/min -rpm	0 → 0,7									2 x 7,5	2 x 5,5		
	6 DVFC 6	m/min	0 → 42 (16 t) 0 → 84 (8 t) 0 → 100 (4 t)									5,5	4,0		

IEC 60204-32	
480 V (+6% -10%) 60 Hz	75 LVFC : 78 kVA 90 HPL™ : 90 → 54 kVA 100 LVF : 98 kVA

75 LVFC 40 Optima

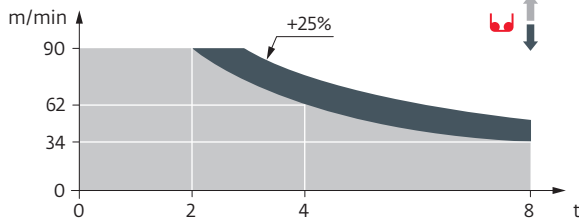

100 LVF 40 Optima

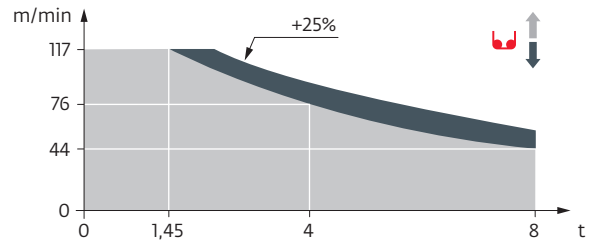

	FR	DE	EN	ES	IT	PT	RU
	Appel de flèche	Auslegerüberhöhung	Jib elevation	Elevación de la flecha	Inclinazione braccio	Desvio da lança	подъем стрелы
	Réactions en service	Reaktionskräfte in Betrieb	Reactions in service	Reacciones en servicio	Reazioni in servizio	Reacções em serviço	Реакция при работе
	Réactions hors service	Reaktionskräfte außer Betrieb	Reactions out of service	Reacciones fuera de servicio	Reazioni fuori servizio	Reacções fora de serviço	Реакция в покое
	Poids total du lest	Ballast-Gesamtgewicht	Total ballast weight	Peso total del lastre	Peso totale della zavorra	Peso total do lastro	Общий вес балласта
	Levage	Heben	Hoisting	Elevación	Sollevamento	Elevação	Подъем
	Distribution	Katzfahren	Trolleying	Distribución	Distribuzione	Distribuição	Перемещение по стреле
	Orientation	Schwenken	Slewing	Orientación	Rotazione	Rotação	Поворот
	Translation	Kranfahren	Travelling	Traslación	Traslazione	Translação	Перемещение крана
	Puissance nominale	Nennleistung	Rated power	Potencia nominal	Potenza nominale	Potência nominal	Номинальная мощность
	Fonction Power Control : vitesses levage «montée» adaptées à la puissance disponible	Funktion Power Control : An die verfügbare Leistung angepasste Hubgeschwindigkeiten „Heben“	Power Control function: „Hoisting“ speeds adapted to the available power	Función Power control (control de la potencia): velocidades de elevación “arriba” adaptada a la energía disponible	Funzione Power Control : velocità del sollevamento «salita» adattate alla potenza elettrica disponibile	Função Power control (controlo de potência): velocidades de elevação “subir” adaptada a energia disponível	Функция Power control: изменение скорости подъема в зависимости от мощности источника питания
	Nous consulter	Auf Anfrage	Consult us	Consultarnos	Consultateci	Consultar-nos	Проконсультируйтесь у нас

	Document commercial non contractuel. Pour toute information technique se référer à la notice correspondante.	Unverbindliches Vertriebsdokument. Für technische Informationen, siehe die entsprechenden Anweisungen.	This commercial document is not legally binding. For any technical information, please refer to the corresponding instructions.	Documento comercial no contractual. Para cualquier información técnica, ver la noticia correspondiente.	Documento commerciale non vincolante, per tutte le informazioni tecniche fare riferimento al catalogo istruzioni.	Documento comercial não contractual. Para qualquer informação técnica complementar consultar as respectivas instruções.	Этот коммерческий документ не является юридически обязательным. Для получения технической информации, см. соответствующие инструкции.
--	--	--	---	---	---	---	---

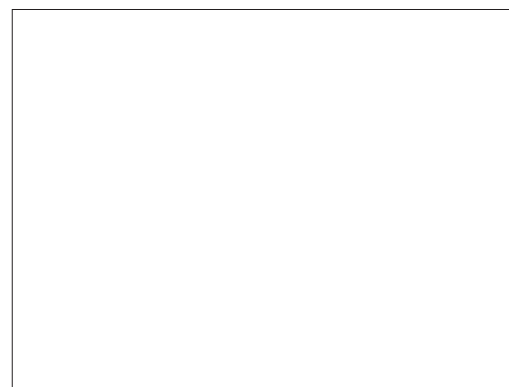

© 2020 The Manitowoc Company, Inc.
www.manitowoc.com