

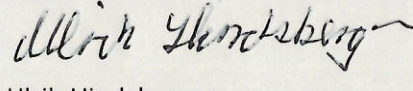

Test Report

REPORT NO:
150442-2

Page 1 of 1
Initials: SCL/UHI
Order no.: 150442-2
Appendix: 4

Customer:	Company: Watercare ApS Address: Stejlebjergvej 14 City: DK-5610 Assens
Material:	<p>The oil separator is a size NS 10, class 1. There is a sludge trap in the bottom of the separator.</p> <p>All materials are PE except the inlet and outlet. The coalescence filter is made of PPI scum. Inlet is \varnothing160 mm and outlet is \varnothing160 for the NS 10 oil separator. A conceptual drawing of the separator is shown in appendix 3. Testing was carried out on a prototype-separator.</p>
Sampling:	The test material was sampled/sent by Watercare and received at the Danish Technological Institute in September 2022. The test material was marked 150442-2
Method:	The test was carried out according to EN 858 - 1, 2002 / 1/A1 - 2005, clause 4, 6.3.1-6.3.8 and 6.5.1. Analysis of the oil content of the water is carried out by Eurofins Denmark which is accredited to carry out these analyses.
Period:	The test separator was sent to the Pipe Centre, Danish Technological Institute in Taastrup by the manufacturer. The test was carried out the 5 th of October 2022.
Result:	The test shows that the separator meets all relevant requirements in CEN standard EN 858-1 /A1 - 2005. With a flow of 10 l/s, there is a content of residual oil at 4.88 mg/l in the discharge. The separator can be placed in class I (maximum 5 mg/l oil in the discharge). The results are shown in appendix 2. Furthermore the separator system follows the requirements of section 6.3.2-6.3.5 and 6.5.1-6.5.3 in the CEN standard EN 858-1 /A1 - 2005.
Terms:	This analysis/test was conducted accredited in accordance with international requirements (ISO/IEC 17025:2005) and in accordance with the General Terms and Conditions of Danish Technological Institute. The test results solely apply to the tested item. This analysis report/ test report may be quoted in extract only if Danish Technological Institute has granted its written consent.
Place:	Dato 18.01.2023, Danish Technological Institute, Taastrup, Pipe Centre
Signatur:	<p> Stig Clausen Consultant - Executive</p> <p> Ulrik Hindsberger Centre Manager - Fellow reader</p>





Appendix 1:

Test conditions, extracts from CEN standard DS/EN 858-1

Reference to section in CEN standard DS/EN 858-1

- 6.2 Materials**
All materials are PE except the inlet and outlet. All metals part is stainless steel. There is no documentation for the properties of the materials. The testing has not included checking specific documentation for the composition and oil-resistance of the materials, and no tests of the materials' tightness and resistance to oleaginous liquids have been carried out, except for tests of the separator's efficiency with subsequent observation, which gives no reason for further comment.
- 6.3.2 Watertightness has been testing according to 8.2**
The system has been tested by filling up water to 40 mm above the maximum operational liquid level. There were no leaks after 20 min of testing. The tightness of the extension shaft has not been tested. If extension shafts are used, the tightness of the connections must be tested after installation.
- 6.3.3 Accessibility**
The separator system including the inlet and outlet is accessible for maintenance and inspection.
- 6.3.4 Water seals**
The separator has a water seal at the inlet and outlet. The water seal is the result of the inlet and outlet being run through closed pipes, which are submerged at least 100 mm under all normal operating conditions.
- 6.3.5 Pipe and pipe joints**
The inlet of the separator is 160 mm and the outlet is 160 mm which is correct according to table 2 in EN 858-1. Inlet and outlet were tight at the watertightness test.
- 6.3.7 Sludge traps**
There is a sludge trap in the bottom of the separator. The volume of the sludge trap is 1350 liters.
- 6.5.1 Safeguard against reflux**
There is no risk of reflux in the inlet during normal operations.
- 6.5.2 Storage Capacity**
Watercare has informed that the storage capacity is calculated to 1600 l. With a capacity of 1600 l there is still a safe distance to the upper edge of the outlet.
- 6.5.3 Automatic closure device**
The separator was equipped with an automatic closure device. Watercare has informed that the automatic closure device only will be installed when necessary.
- 6.5.6 Determination of the nominal size and class**
The oil separator has been testing according to 8.3.3.



8.3.3

A. Surface levels in the separator

During testing with a flow of 10 l/s there is more than 60 mm from the upper edge of the separator to the water level.

B. Separator efficiency

The test was carried out as described in EN 858-1.

The samples in the separator outlet were taken through an inclined tube to the sample bottle.

The following tests use an oil type with specifications corresponding to ISO 8217, ISO-F-DMA, with a density of $0.85 \pm 0.015 \text{ g/cm}^3$ at 12°C.

C. Method

The separator is measured and the dimensions noted on the manufacturer's drawing.

The separator is filled with water up to the outlet. The volume of water is called: $V_K = 1385$ litres. The slugde trap were blocked off with small stones during the test.

Flow 10 l/s

Water at 10 l/s and oil at 50 ml/s (5 ml per l/s) is added for a period of:

$T_B = 4 \times V_K / Q_w \times 60$ minutes (though at least 15 minutes) plus the test period T_p , which is 5 minutes.

$T_B = 9.23$ minutes. **Oil is added for 15 minutes + 5 minutes, i.e. a total of 20 minutes.**

In the period T_p , samples are taken from the outlet directly to the sample bottle in the **first** minute after T_B , and then a further 4 samples at 1-minute intervals.

The 5 samples are analysed separately, and the test results given as the arithmetic calculated mean value.

Total quantity of oil: 60 l

6.6.1

Marking

The separator is marked "Watercare 223372110". The manufacturer has stated that operating and maintenance instructions are enclosed with the separator on delivery.

9.2

Conformity of the test separator with the submitted drawings

The conformity of the test separator with the manufacturer's construction drawings has been controlled. The main dimensions tally with the manufacturer's drawing.



Appendix 2: Test results

Sample glass no.	051001	051002	051003	051004	051005
Test/minutes	16	17	18	19	20

Results from analysis

Sample label	Variable	Result	Unit	Method used
Sample glass 051001	Total hydrocarbon	3.9	mg/l	EN 858-1, 2002
Sample glass 051002	Total hydrocarbon	4.1	mg/l	EN 858-1, 2002
Sample glass 051003	Total hydrocarbon	5.2	mg/l	EN 858-1, 2002
Sample glass 051004	Total hydrocarbon	5.6	mg/l	EN 858-1, 2002
Sample glass 051005	Total hydrocarbon	5.6	mg/l	EN 858-1, 2002
Arithmetic mean	Total hydrocarbon	4.88	mg/l	



Appendix 3: Drawing and pictures from the test

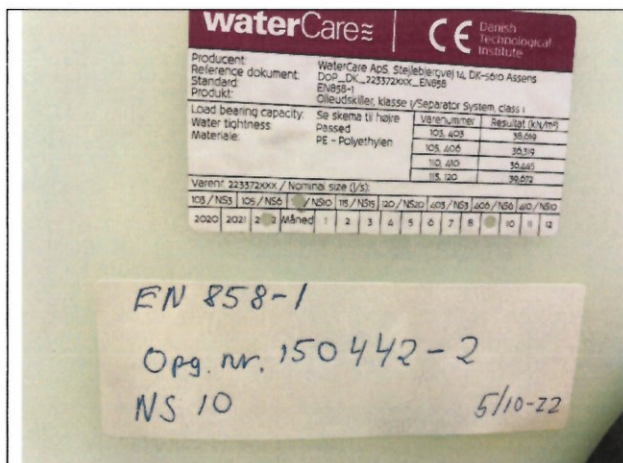
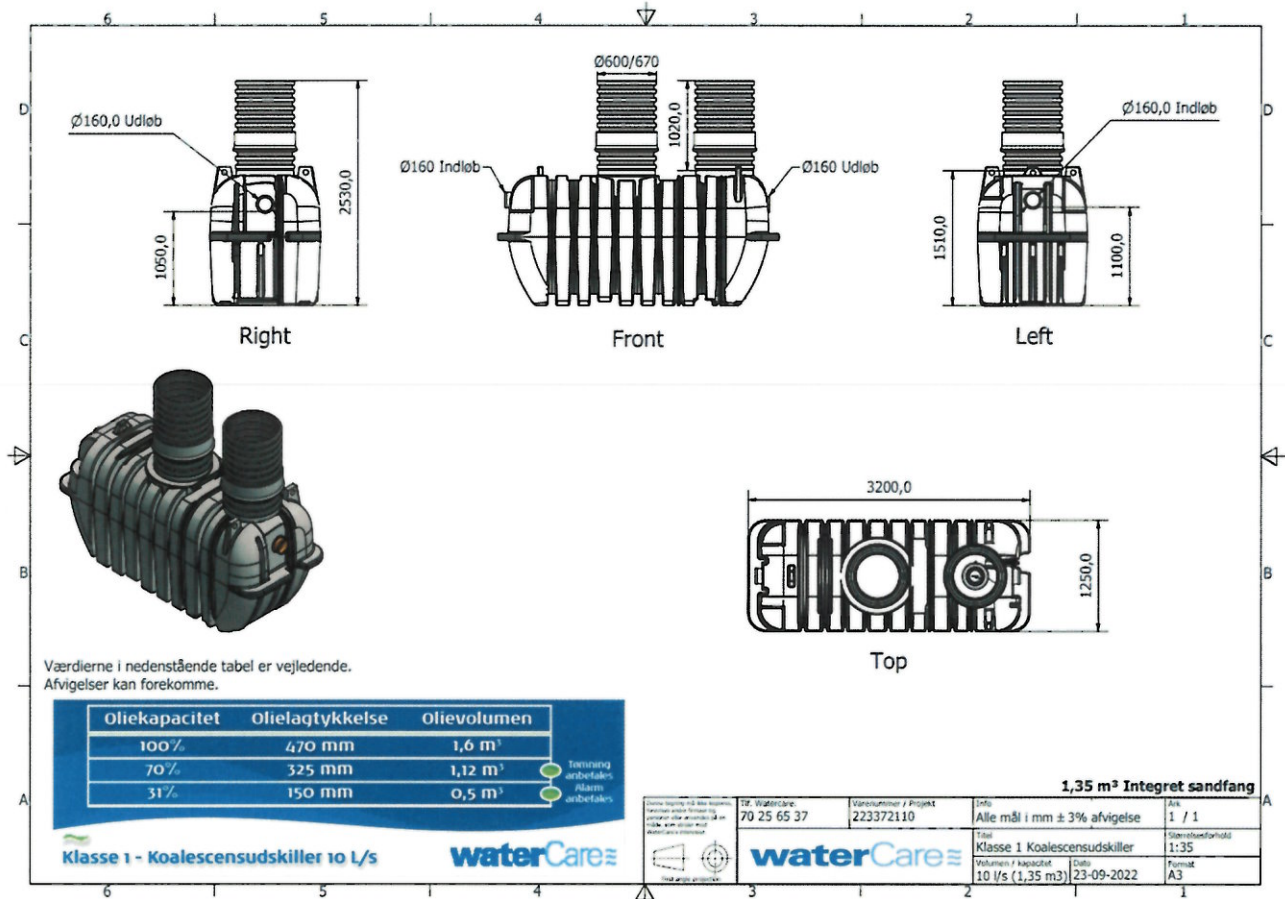



Appendix 3: Drawing and pictures from the test (continued from previous page)

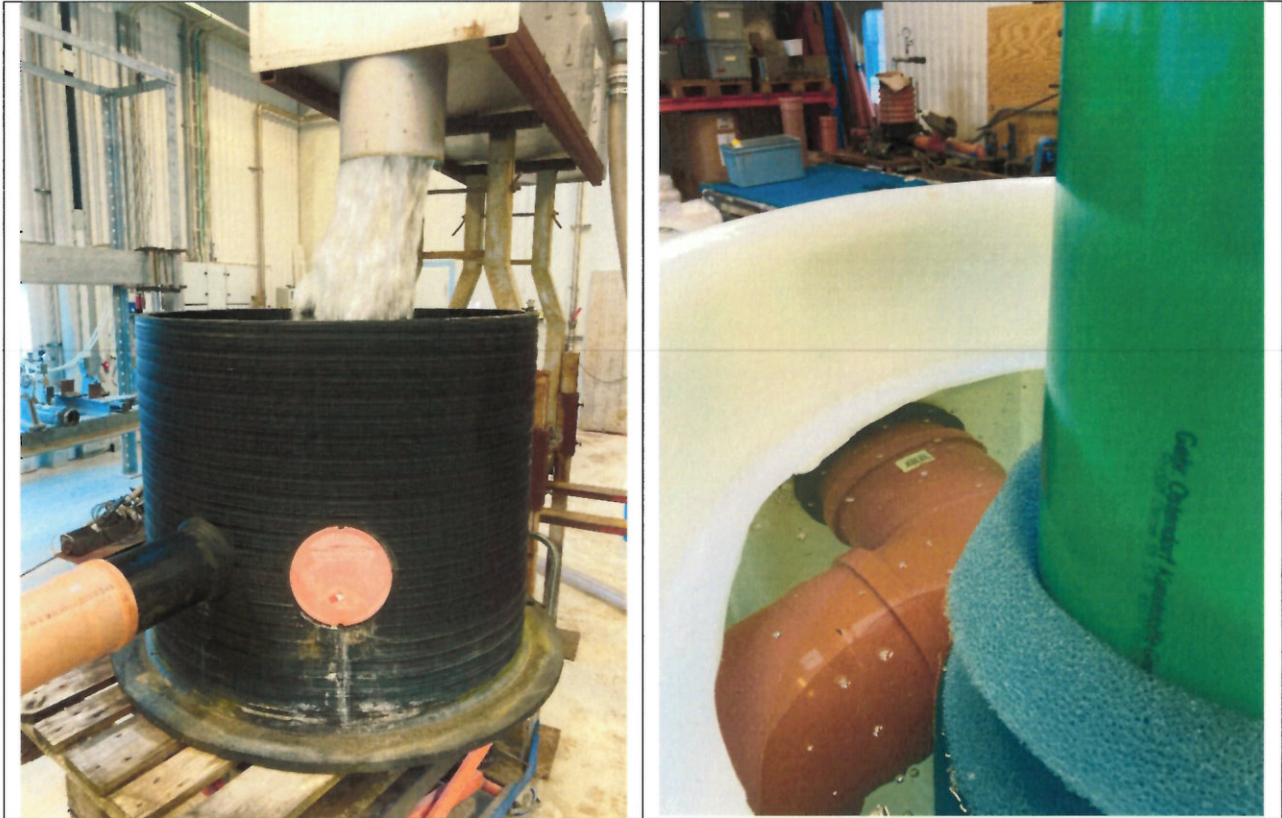

Appendix 4:

In accordance with Regulation (EU) No. 305/2011 of the European Parliament and of the Council, the Construction Products Regulation (CPR), the test was conducted for the purpose of the assessment of the performance under AVCP System 3 as described in Regulation (EU) No. 568/2014 and in compliance with all applicable provisions of the CPR. The Danish Technological Institute is a notified body in accordance with CPR Article 48.

January 2021