

Installations- und
Gebrauchsanweisung



Gewächshaus

HARVEST 283x471 cm

GH-HA-280-471

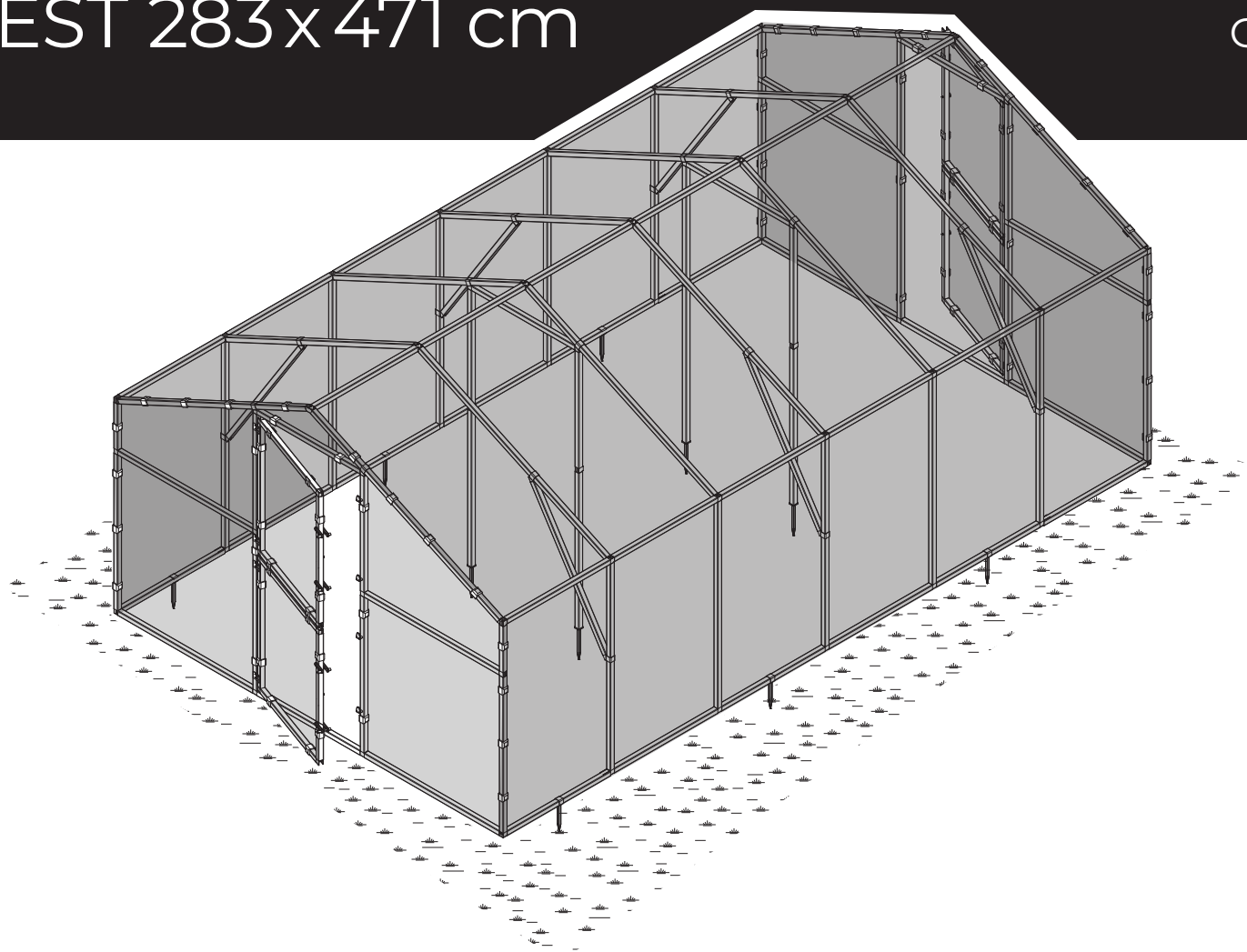

DE

EN

DE Informationen zum Foliengewächshaus Harvest

Vielen Dank, dass Sie sich für das Gewächshaus von BioGreen entschieden haben. Wir hoffen, dass es beim Anbau von Blumen und Gemüse hilfreich sein und Ihren Bedürfnissen entsprechen wird. Wir haben alle Anstrengungen unternommen, um sicherzustellen, dass die Konstruktion und die modernen technischen Lösungen bei dem Anbau hilfreich sind und das Zusammensetzen des Modells nicht zu viele Probleme bereitet.

WARNUNG!

Das Foliengewächshaus ist nicht zur Montage in offenen Feldern oder an Orten, an denen die Konstruktion auf starken Wind ausgesetzt ist, vorgesehen. Es sollten immer an einem windgeschützten Ort installiert werden, der keinem direkten Wind ausgesetzt ist - dies schützt das Foliengewächshaus vor Beschädigungen. Die Folie sollte im Winter nicht auf dem Gewächshaus belassen werden, da sie unter Schneedruck beschädigt werden kann.

Büsche mit Feldfrüchten sollten nicht an das Skelett gebunden werden (z. B. Tomaten), da dies die Konstruktion erheblich schwächen kann.

Regeln für die sichere Verwendung:

1. Das Gewächshaus dient ausschließlich zum Anbau von Pflanzen.
2. Graben Sie die überschüssige Folie immer in den Boden ein - es ist ein Element, das das Foliengewächshaus vom Wegblasen durch den Wind schützt.
3. Installieren Sie es an einem Ort, der keinen starken Windböen ausgesetzt ist. Vermeiden Sie Hügel und Freiflächen
4. Nicht bei starkem Wind oder anderen schlechten Wetterbedingungen montieren.
5. Stellen Sie sicher, dass sich keine Kinder am Montageort befinden, da das Set aus kleinen Elementen und Plastiktüten besteht, die Erwürgungen oder Ersticken verursachen können.
6. Überprüfen Sie regelmäßig die Stabilität des Gewächshauses, insbesondere nach starkem Wind. Wenn Schäden festgestellt werden, ist das beschädigte Element zu ersetzen oder das Objekt zu zerlegen.
7. Verwenden Sie während der Montage ausschließlich die im Handbuch angegebenen Werkzeuge. Tragen Sie während der Wartung und Montage des Objekts Schutzhandschuhe und eine Schutzbrille.
8. Vermeiden Sie das Mähen mithilfe von Rasenmähern und Freischneidern in der Nähe des Objekts.
9. Lagern Sie keine heißen Gegenstände im Gewächshaus, insbesondere keine heißen Grills usw.
10. Entfernen Sie im Winter immer die Folie von dem Gewächshaus und sichern Sie die Konstruktion so, damit sie nicht vom Wind weggeblasen wird.
11. Klettern Sie niemals auf das Dach des Objekts.
12. Lassen Sie Kinder nicht unbeaufsichtigt im Gewächshaus, da sich die Türen von alleine oder durch Wind schließen können
13. Verwenden Sie kein offenes Feuer im Objekt oder in seiner unmittelbaren Nähe.
14. Belasten Sie die Dachspannweiten nicht zusätzlich.
15. Der Tunnel dient nicht zur Nutzung im öffentlichen Raum.

ARBEITSSCHUTZ UND HYGIENE: BEFOLGEN SIE BESTIMMUNGEN ZUM ARBEITSSCHUTZ und ZUR ARBEITSHYGIENE



Montage
in Schutzhandschuhen
durchführen



Montage in Schutzbrille
durchführen



Montage in Anwesenheit
eines Helfers durchführen

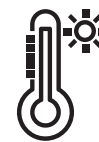

Nur bei gutem
Wetter aufbauen



Führen Sie die Montage
an einem windstillen Tag durch



Es ist untersagt, die Einrichtung
nach dem Konsum von Alkohol
oder Rauschmitteln zu montieren

EN Information about the Harvest foil greenhouse

Thank you for choosing the BioGreen greenhouse. We hope that it will be useful for growing flowers and vegetables and that it will meet your needs. We have made every effort to ensure that the construction and modern technical solutions are helpful in cultivation and that the assembly of the model does not cause too many problems.

WARNING!

The foil greenhouse is not intended for installation in open fields or in places where the structure is exposed to strong winds. It should always be installed in a sheltered location that is not exposed to direct wind - this protects the film greenhouse from damage. The film should not be left on the greenhouse in winter, as it can be damaged by snow pressure.

Do not tie up the shrubs with crops to the framework (e.g. tomatoes) – this may impair the structure greatly.

Safe use rules:

1. the greenhouse is used exclusively for growing plants.
2. always bury the excess foil in the ground - it is an element that protects the foil greenhouse from being blown away by the wind.
3. install it in a place that is not exposed to strong gusts of wind. Avoid hills and open spaces
4. do not install in strong winds or other bad weather conditions
5. make sure that there are no children at the installation site, as the set consists of small elements and plastic bags that can cause strangulation or suffocation.
can cause strangulation or suffocation.
6. regularly check the stability of the greenhouse, especially after strong winds. If damage is detected, replace the damaged element or dismantle the replace the damaged element or dismantle the object.
7. only use the tools specified in the manual during assembly. During maintenance and assembly of the object, wear wear protective gloves and safety goggles.
8. avoid mowing with lawn mowers and brush cutters in the vicinity of the object.
9. do not store hot objects in the greenhouse, especially hot barbecues etc.
10. always remove the film from the greenhouse in winter and secure the structure so that it is not blown away by the wind.
- 11 Never climb onto the roof of the object.
- 12 Do not leave children unattended in the greenhouse, as the doors may close on their own or due to wind.
13. do not use naked flames in the object or in its immediate vicinity.
- 14 Do not place any additional load on the roof spans.
- 15 The tunnel is not intended for use in public areas.

Follow the OHS Rules



Wear protective gloves during the assembly



Wear protective glasses during the assembly



Provide help from the assistant during the assembly

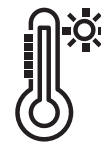

Only set up in good weather



Perform assembly on days which are not windy







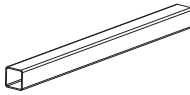
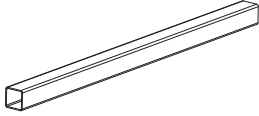
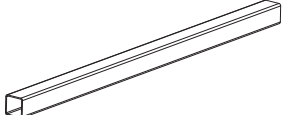
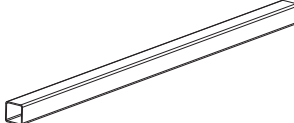
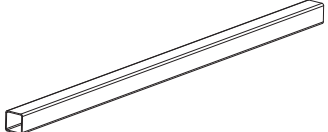
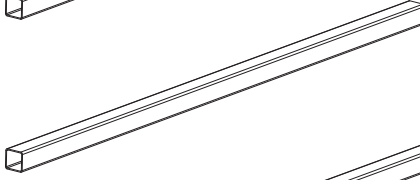
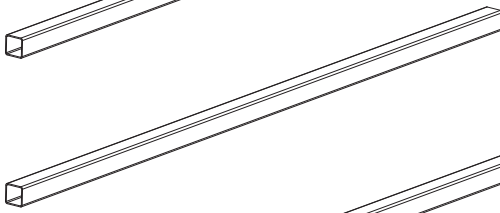
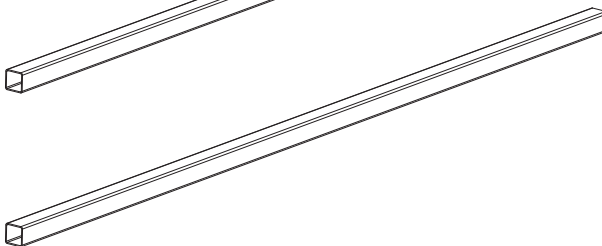

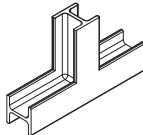
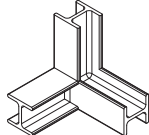

It is prohibited to have the structure assembled by drunk and intoxicated personnel

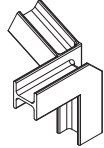
List of elements

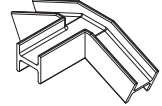
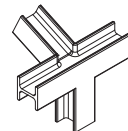
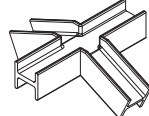
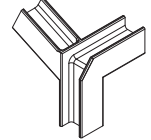
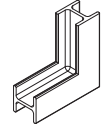
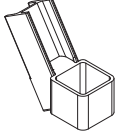
-  **x4** - 290mm
P-13
-  **x8** - 680mm
P-06
-  **x8** - 730mm
P-03
-  **x36** - 750mm
P-01
-  **x8** - 795mm
P-16
-  **x26** - 980mm
P-02
-  **x10** - 1300mm
P-12
-  **x14** - 1500mm
P-10

DE Verzeichnis der Elemente

-  **x22**
Z-05
-  **x4**
Z-01
-  **x4**
Z-15
-  **x2**
Z-07
-  **x8**
Z-11
-  **x2**
Z-09
-  **x10**
Z-08
-  **x5**
Z-10
-  **x2**
Z-06
-  **x16**
Z-03
-  **x12**
Z-11A
-  **x80**
Z-14
-  **x6**
SZ-1
-  **x4**
SZ-2

List of elements

DE Verzeichnis der Elemente

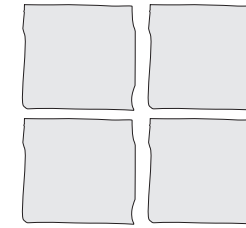
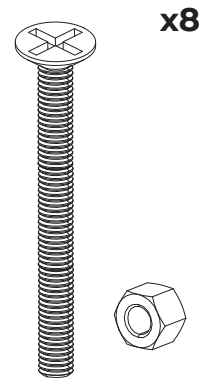
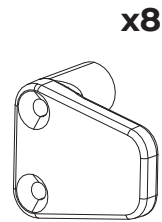
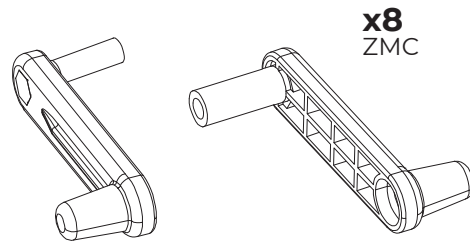

x4
EN FOIL 1 FOR THE DOOR
DE FOLIE 1 FÜR DIE TÜR

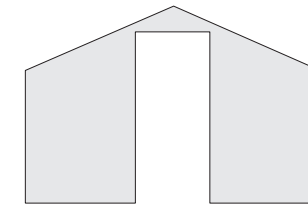

x2
EN FOIL 2
DE FOLIE 2

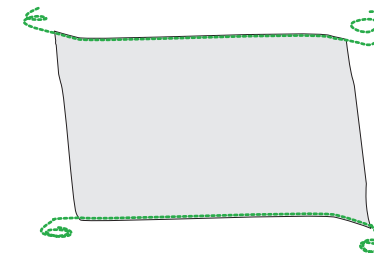
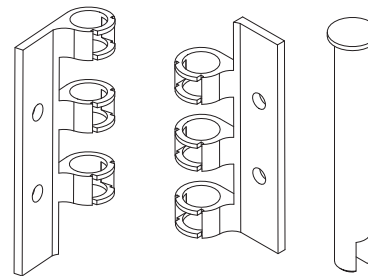
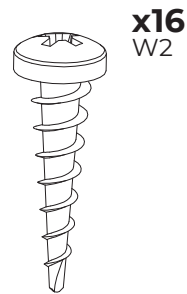
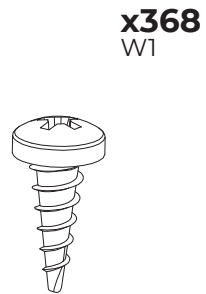

x1
EN FOIL 3
DE FOLIE 3

Tools

DE Werkzeuge



EN The DIY assembly foil greenhouse lacks some tools. Provide necessary tools before starting work. **DE** Das Foliengewächshaus zur Eigenmontage enthält manche Arbeitswerkzeuge nicht. Vervollständigen Sie die Werkzeuge, bevor Sie mit der Arbeit beginnen.

x1

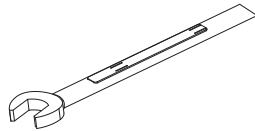

EN SPANNER 6
DE SCHLÜSSEL 6

x1

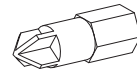

EN BIT
DE KREUZ-BIT

x1

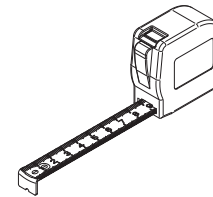

EN MEASURING TAPE
DE MAß

x1

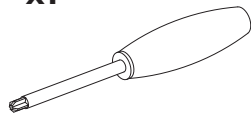

EN SCREWDRIVER
DE KREUZSCHRAUBENZIEHER

x1

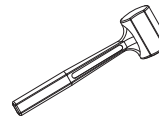

EN RUBBER HAMMER
DE GUMMIHAMMER

x1

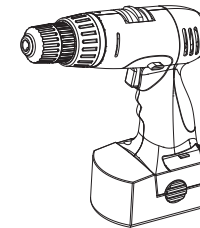

EN DRILL DRIVER
DE SCHRAUBENDREHER

x1

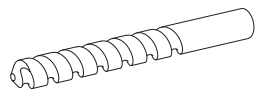

EN 12 MM DRILL
DE BOHRER 12 MM

x1



EN CISSORS
DE SCHERE

1

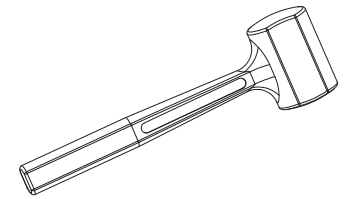
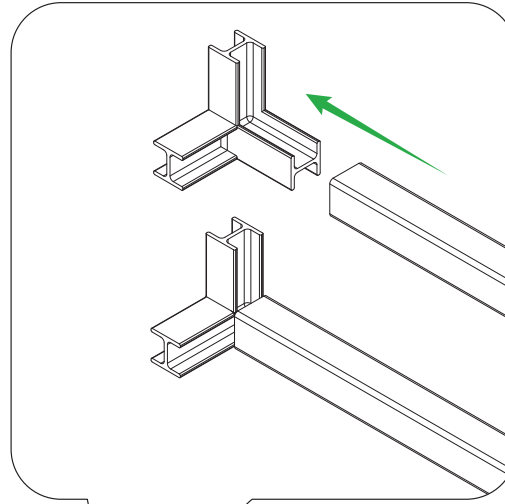
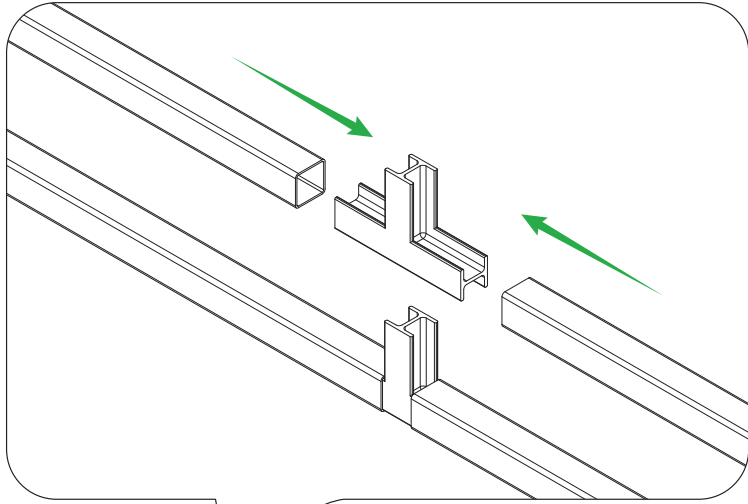

EN Hammer in the profiles with a rubber hammer (not a steel one)
DE Die Profile mittels Gummihammer (nicht Stahlhammer) einschlagen

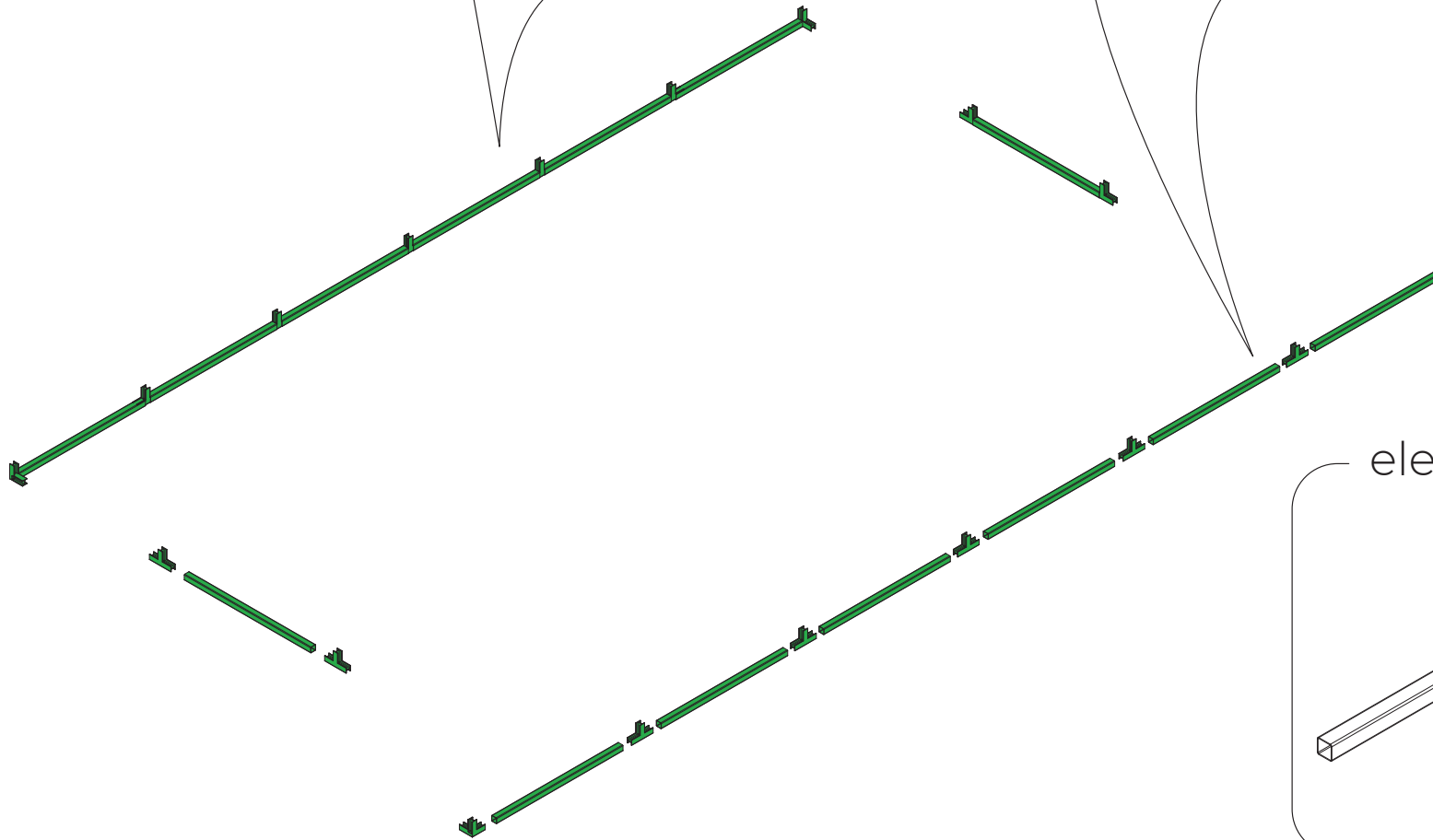

elements

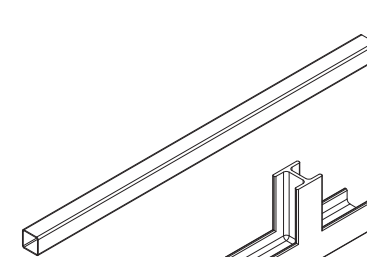

x14 - 750mm
P-01

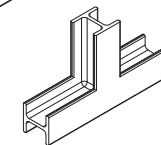

x14
Z-05

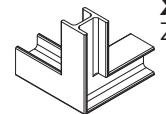

x4
Z-01

2



EN HAMMER IN THE ANCHORING ELEMENT SZ-1 INTO THE GROUND
DE ANKERELEMENT SZ-1 IN DIE ERDE EINSCHLAGEN

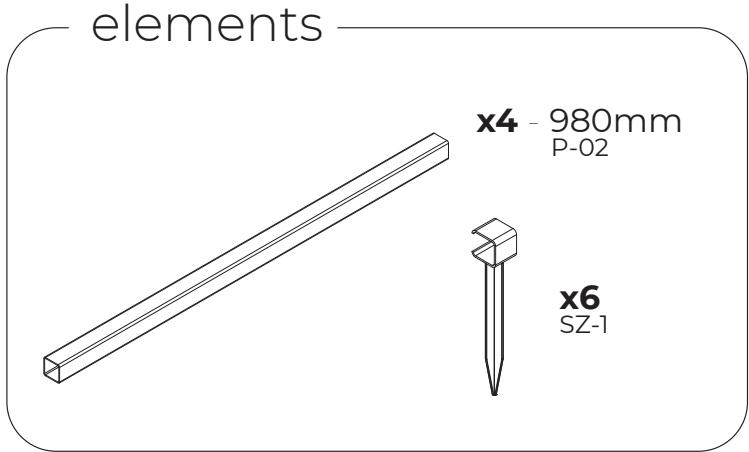
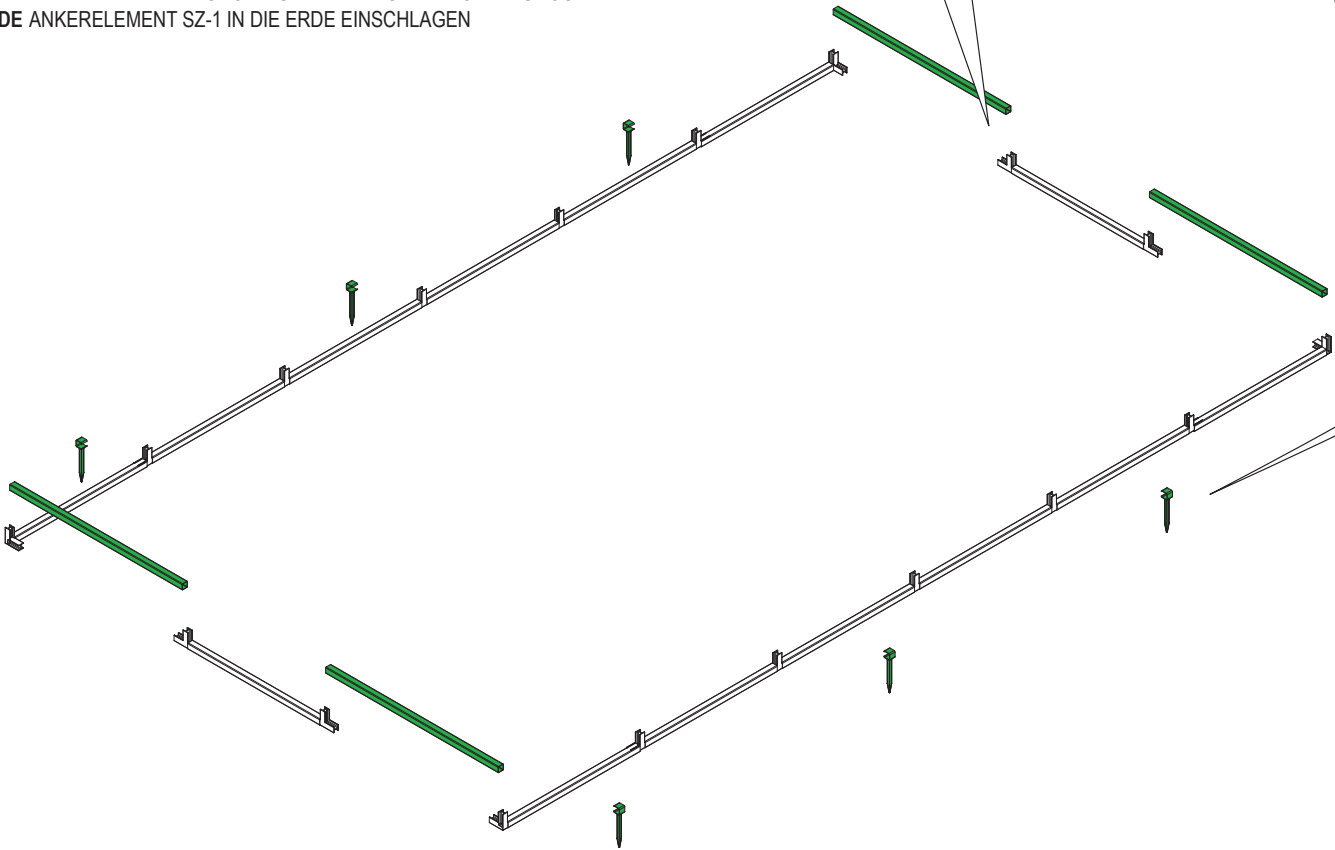
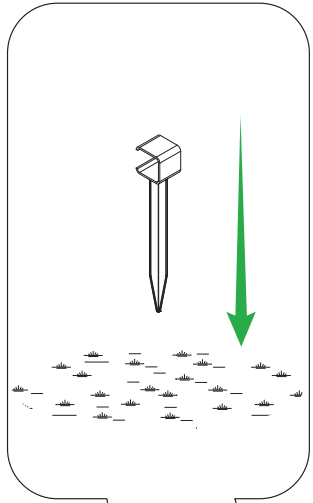
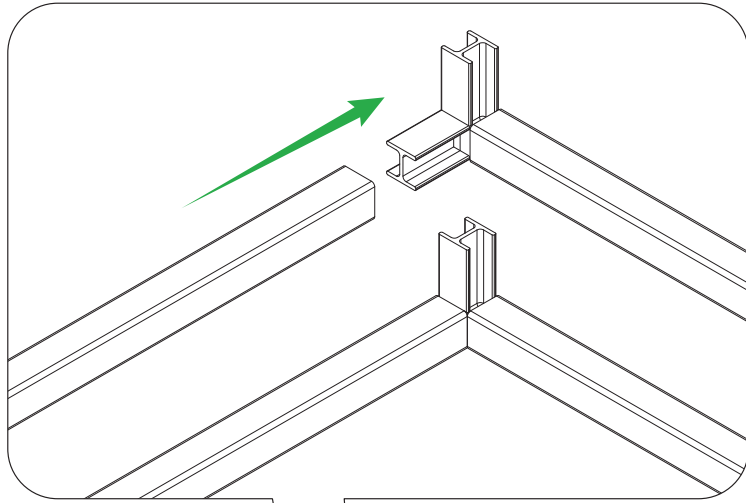
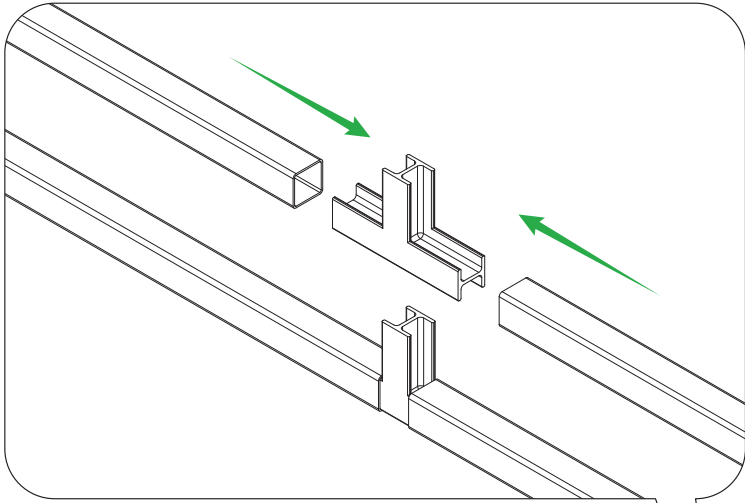

3

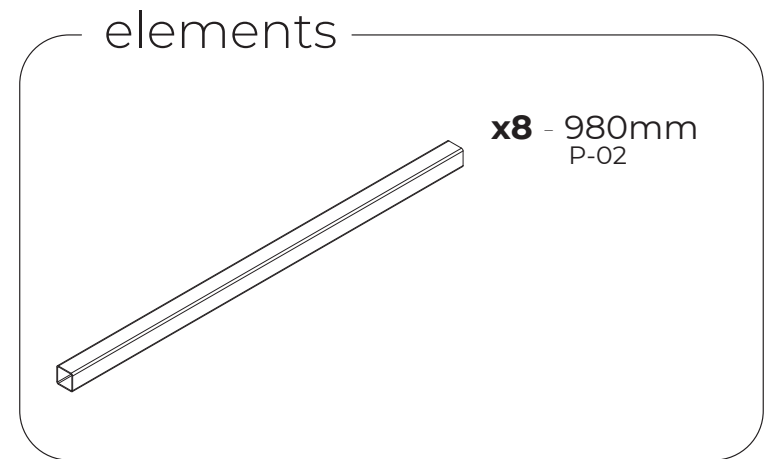
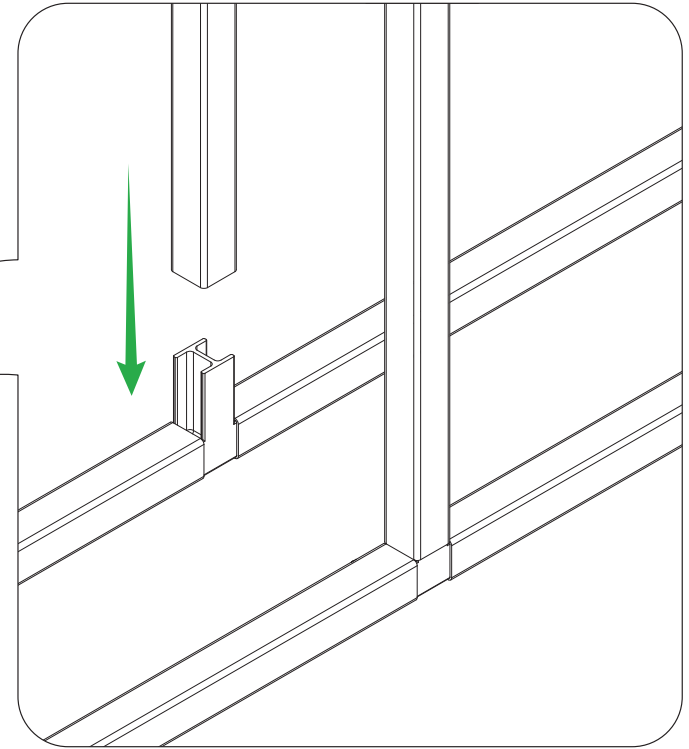
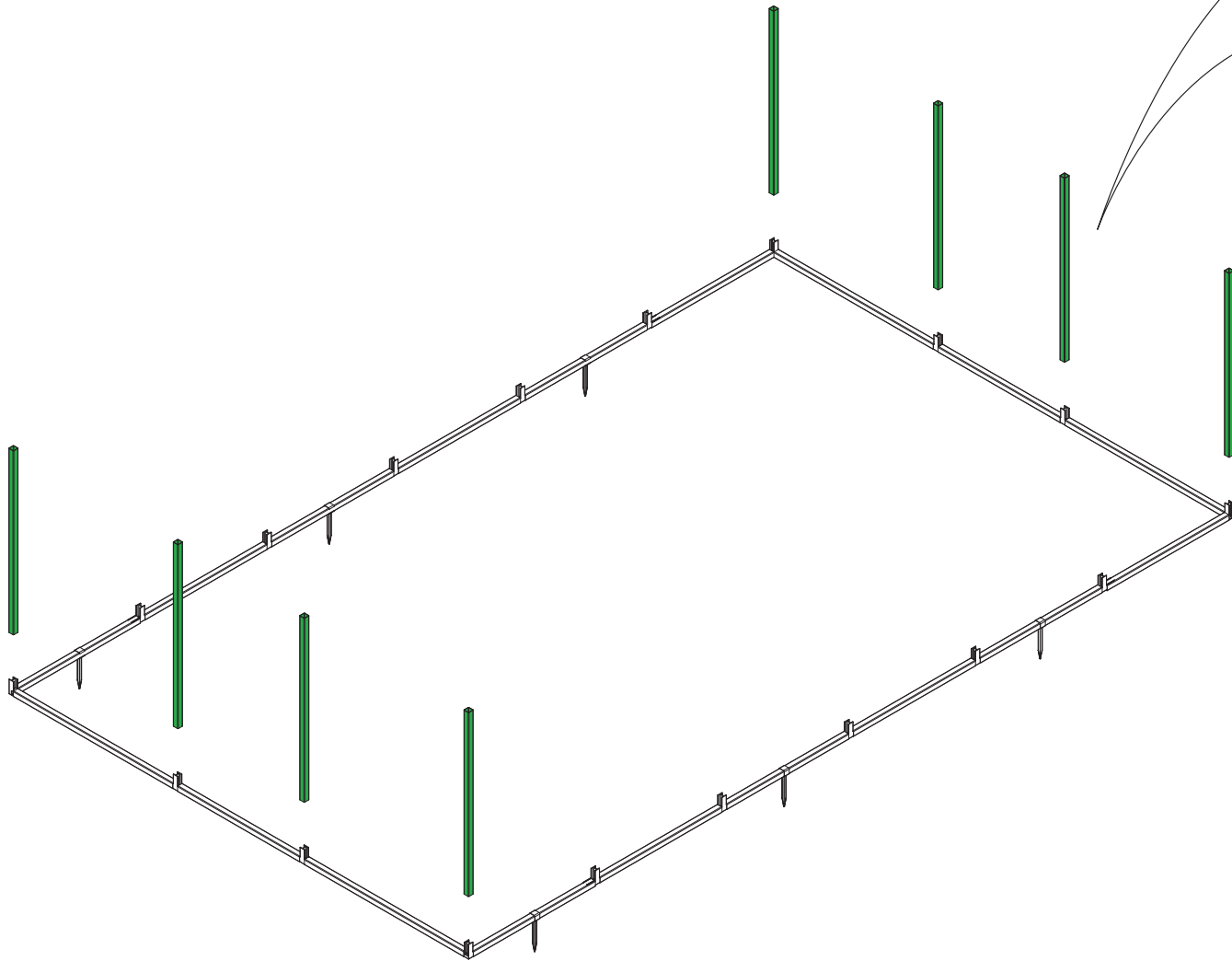

4

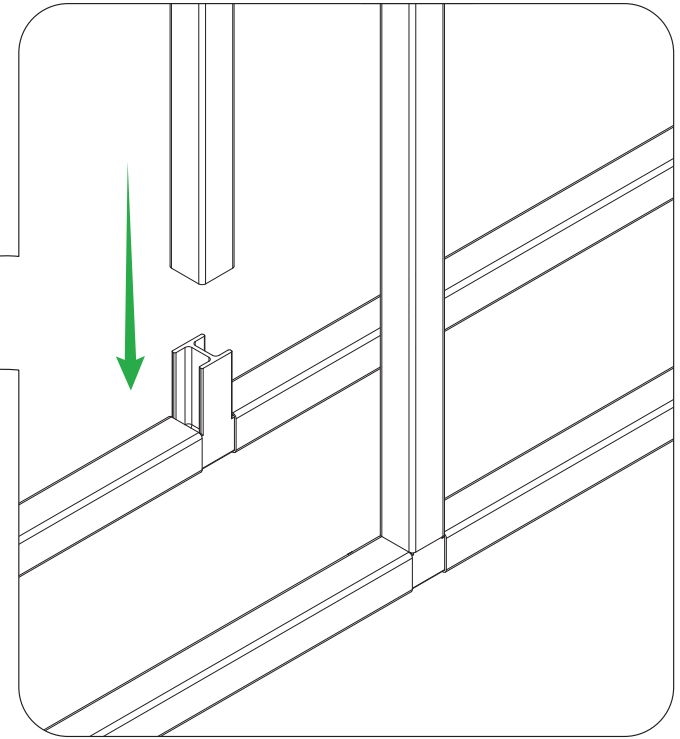
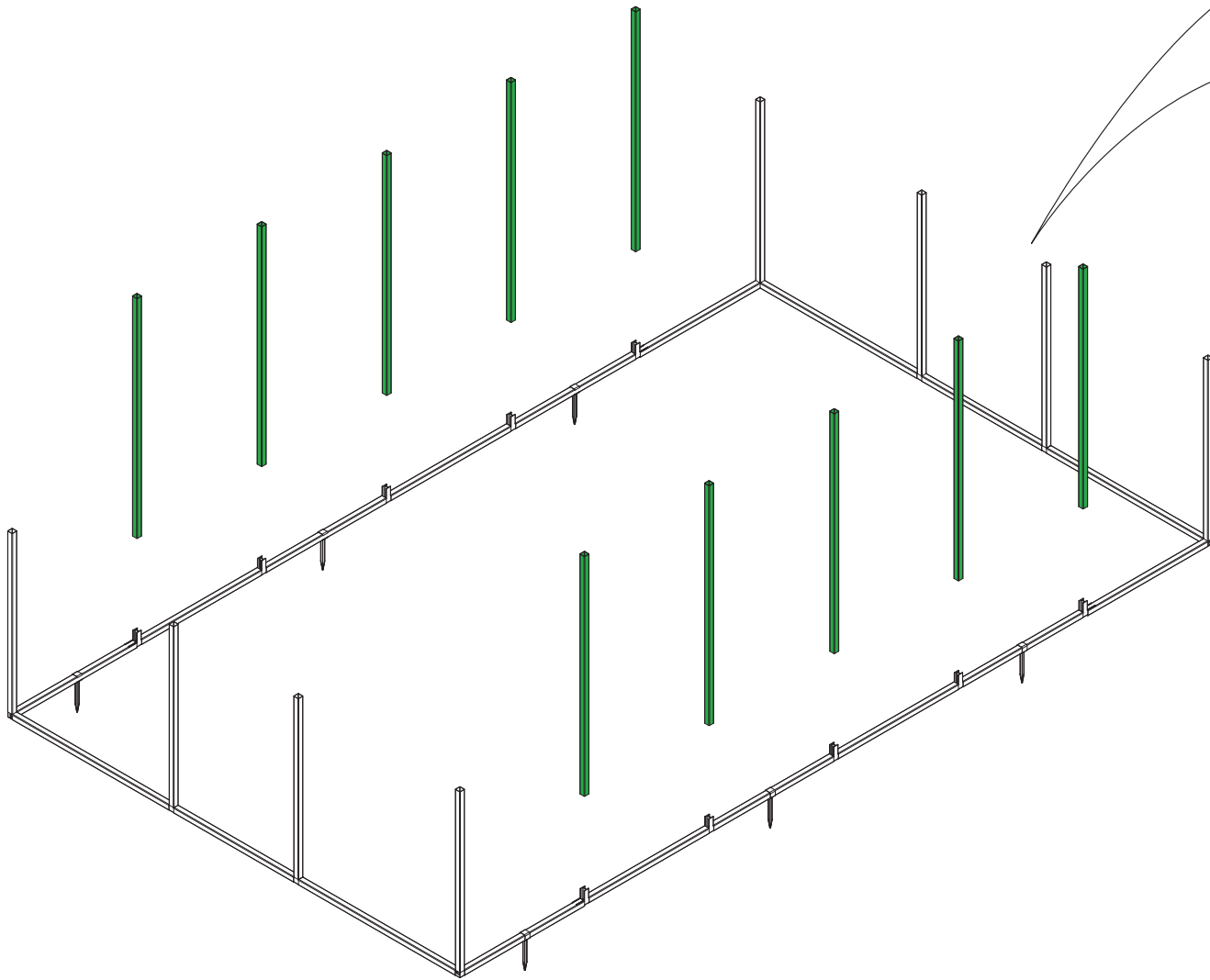

elements

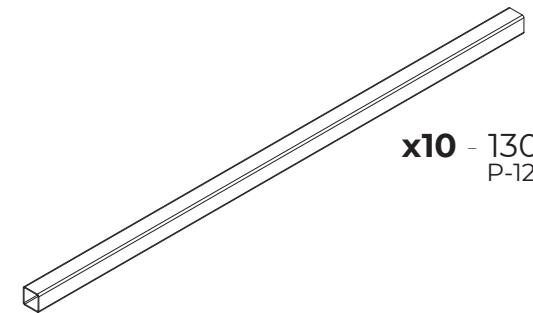

x10 - 1300mm
P-12

5

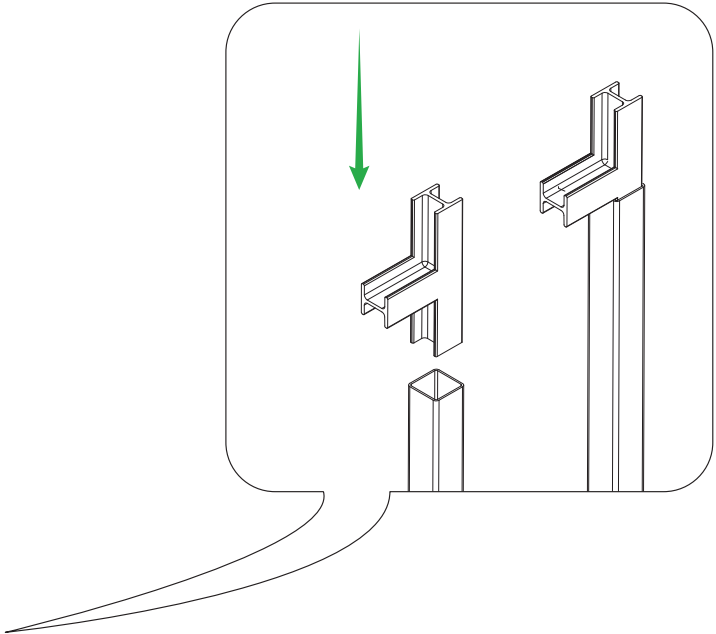
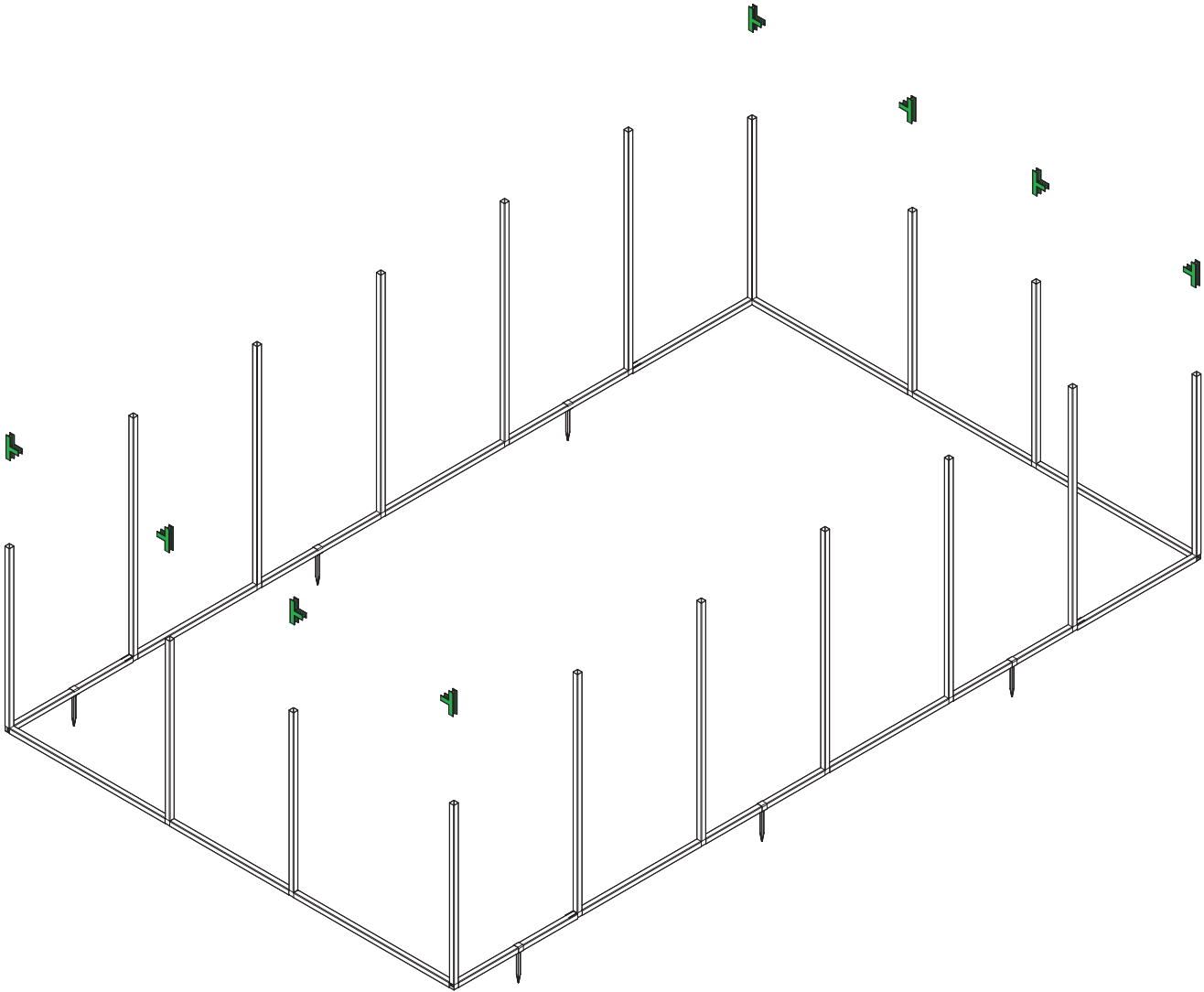

elements

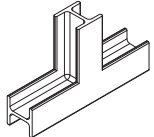

x8
Z-05

6

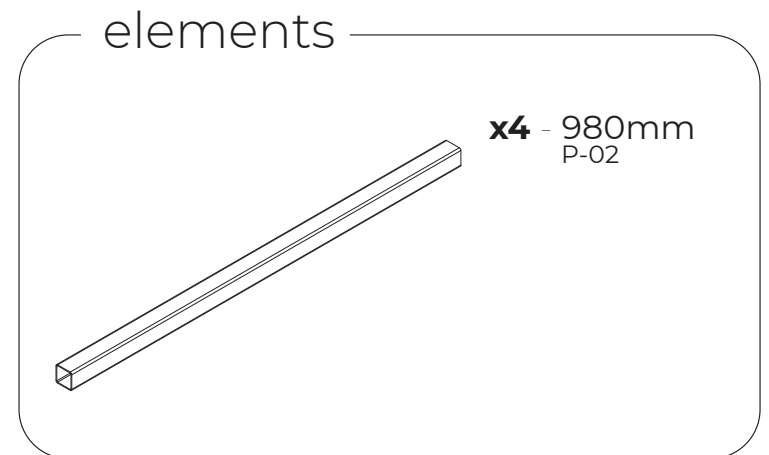
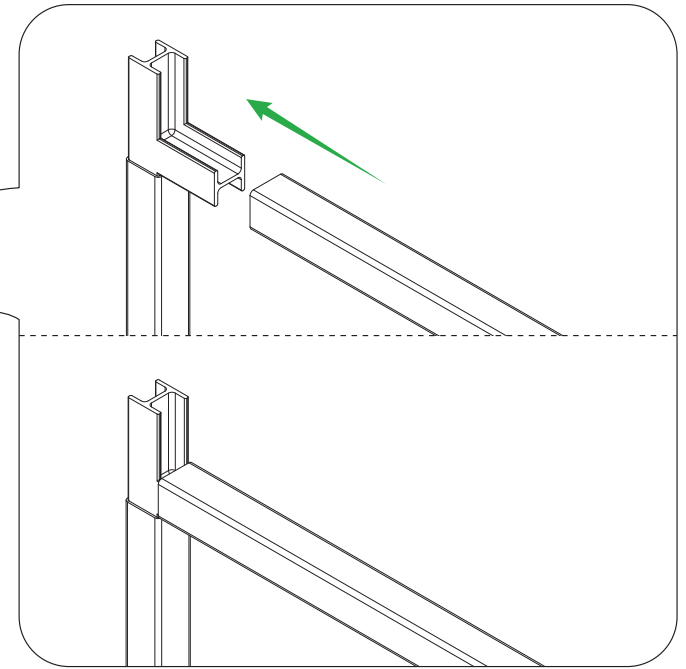
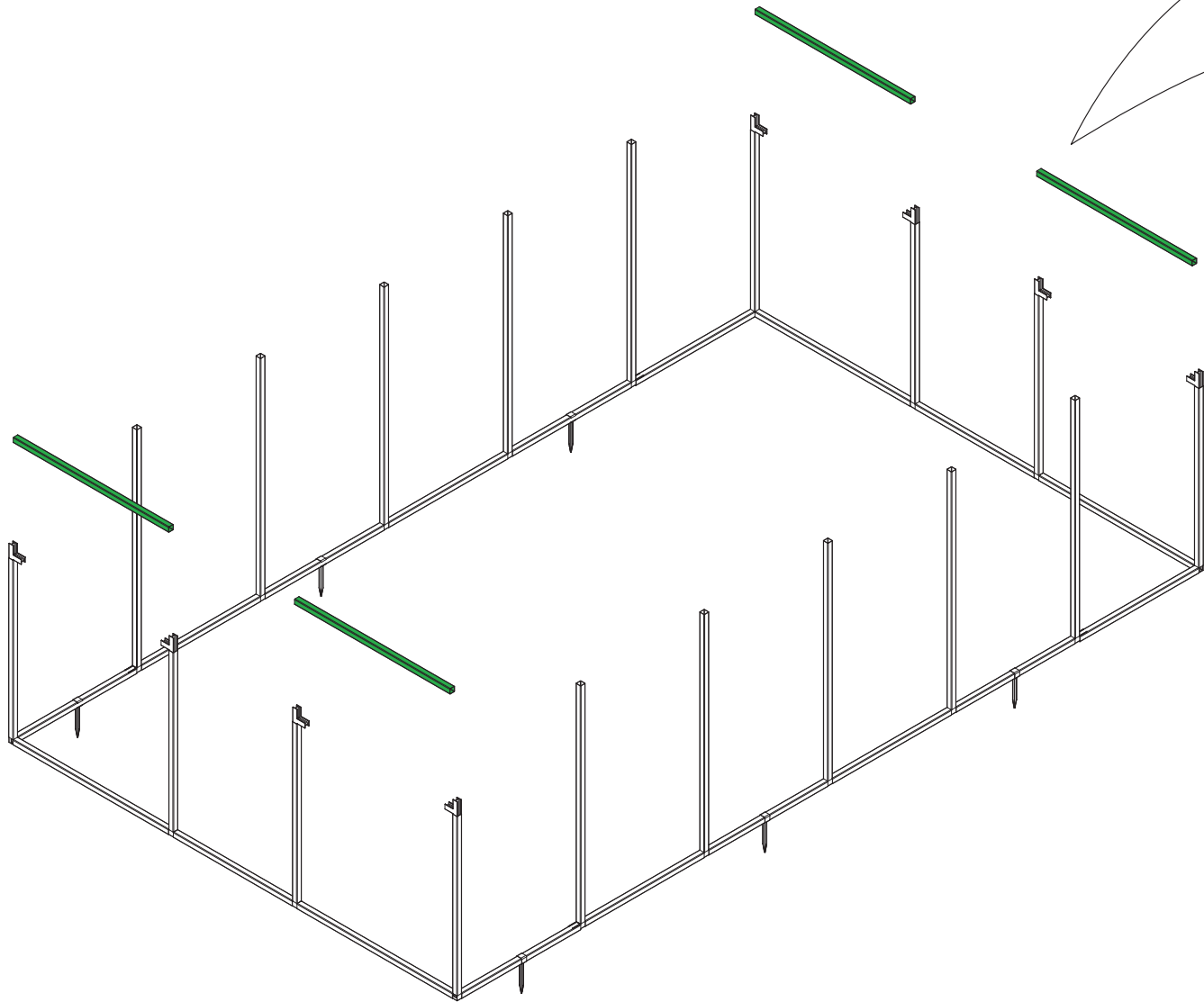

7

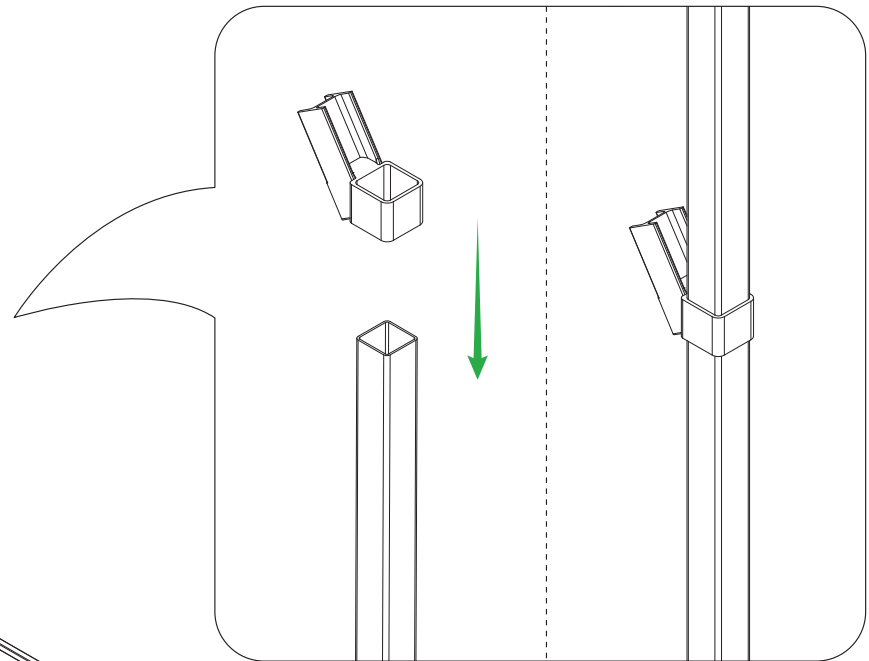
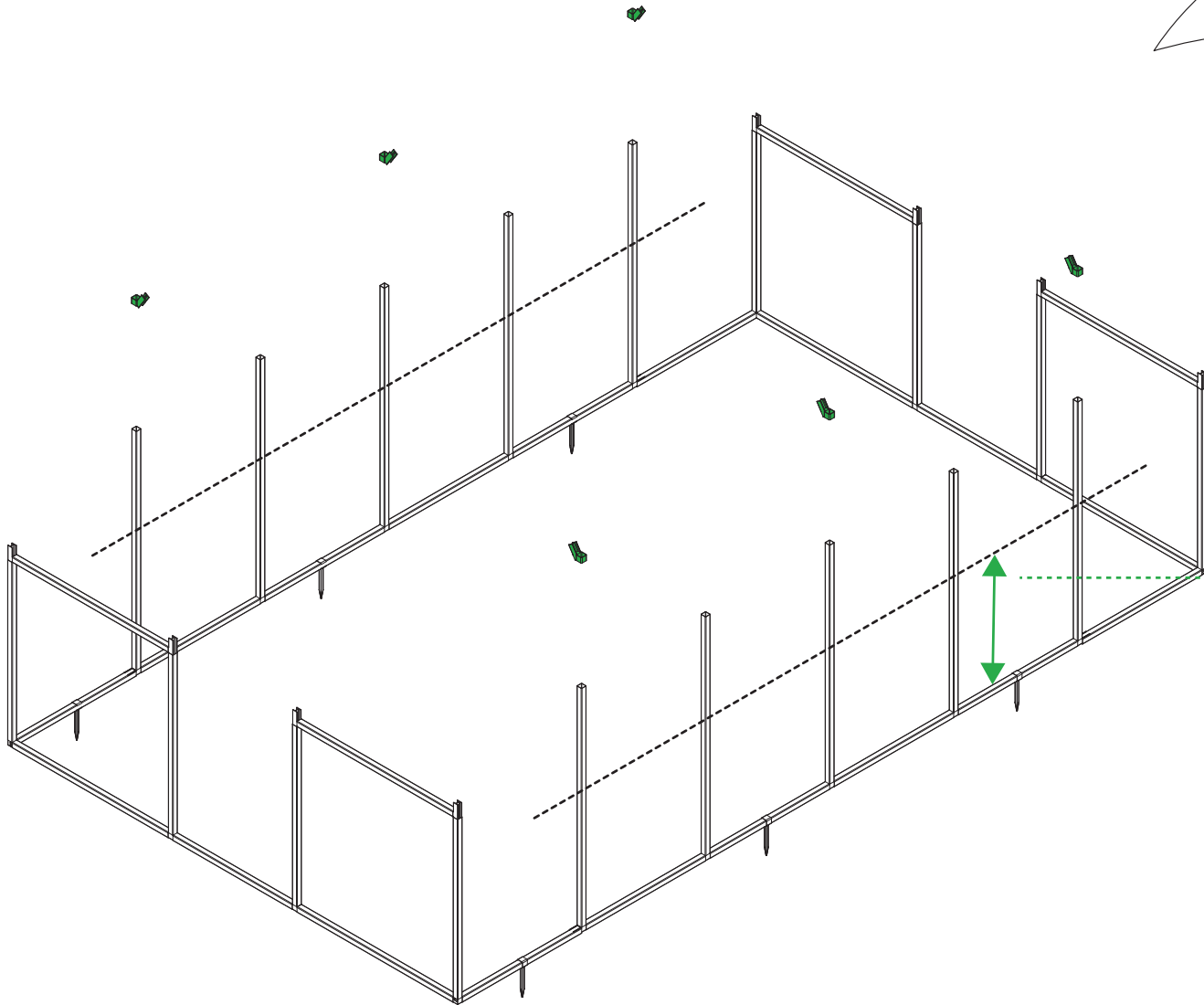

EN About 710 mm from the ground to the connector Z-11A
DE ca. 710 mm vom Boden zum Verbindungsstück Z-11A

elements

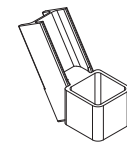

x6
Z-11A

8

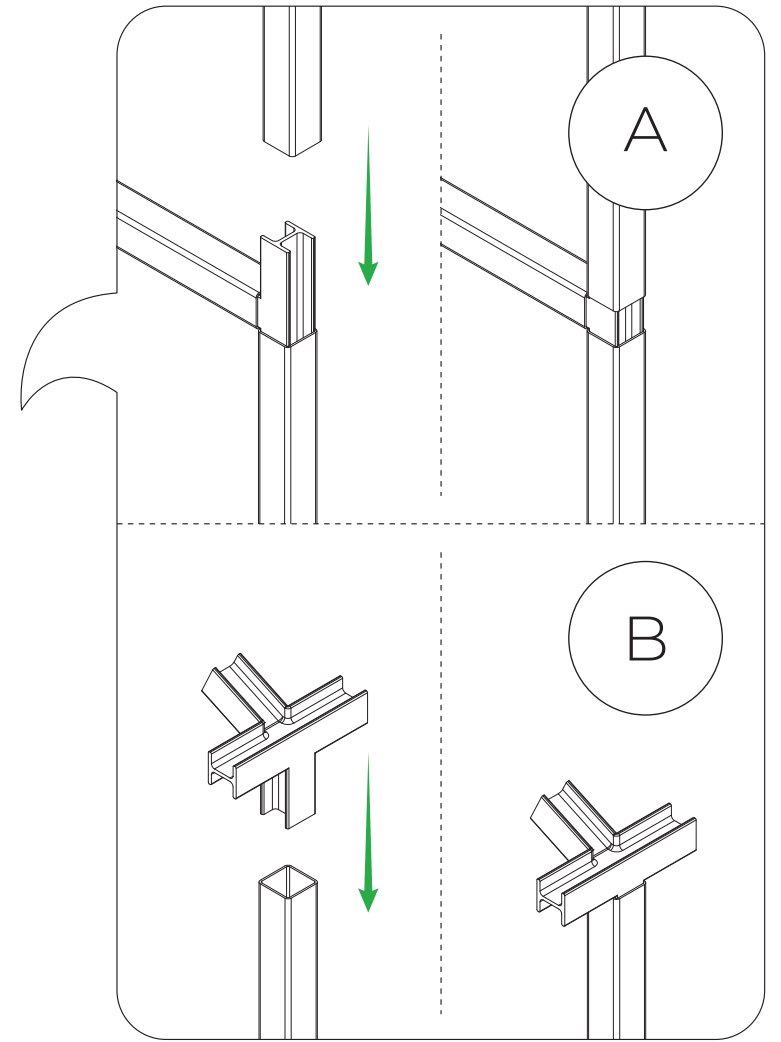
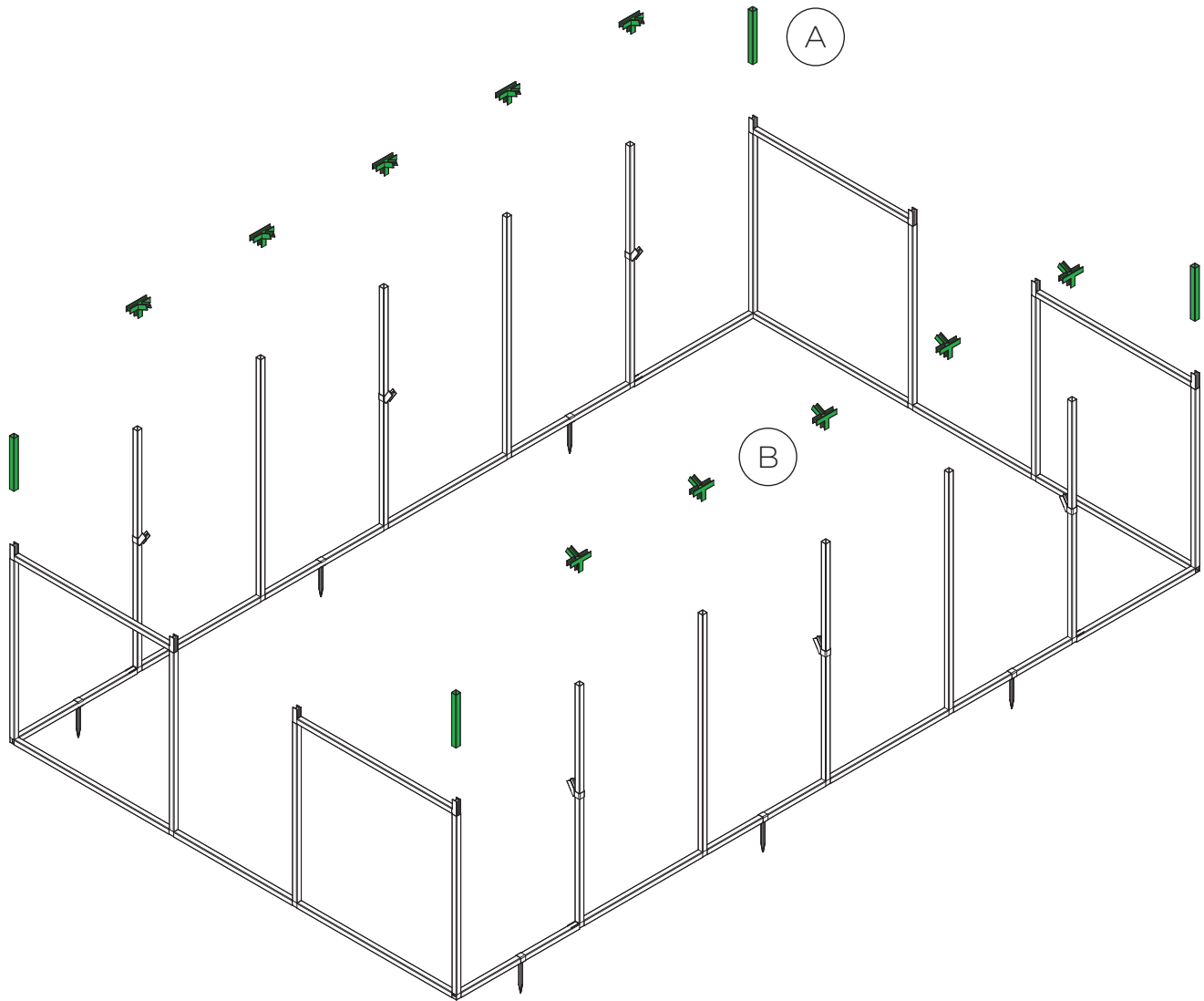

elements

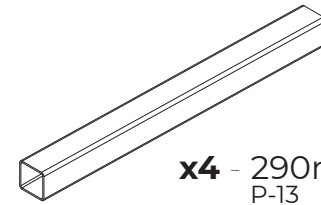

x4 - 290mm
P-13

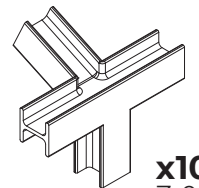

x10
Z-08

9

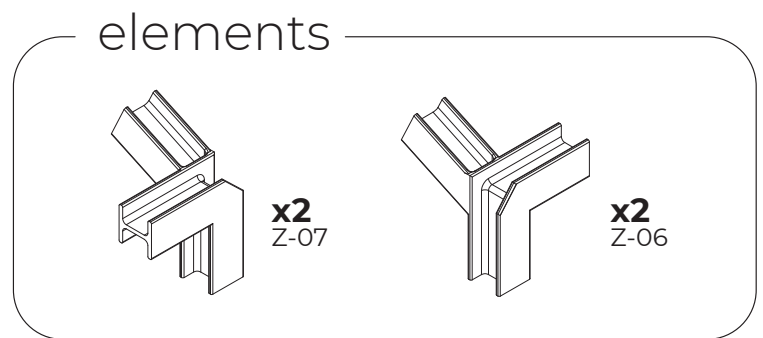
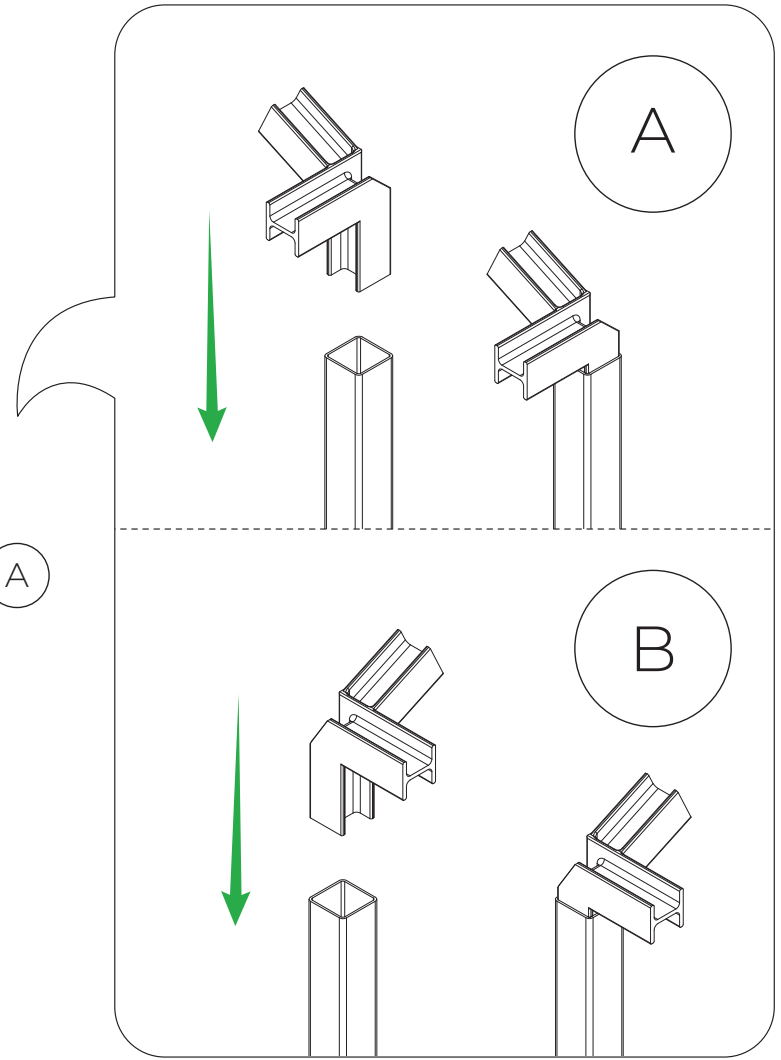
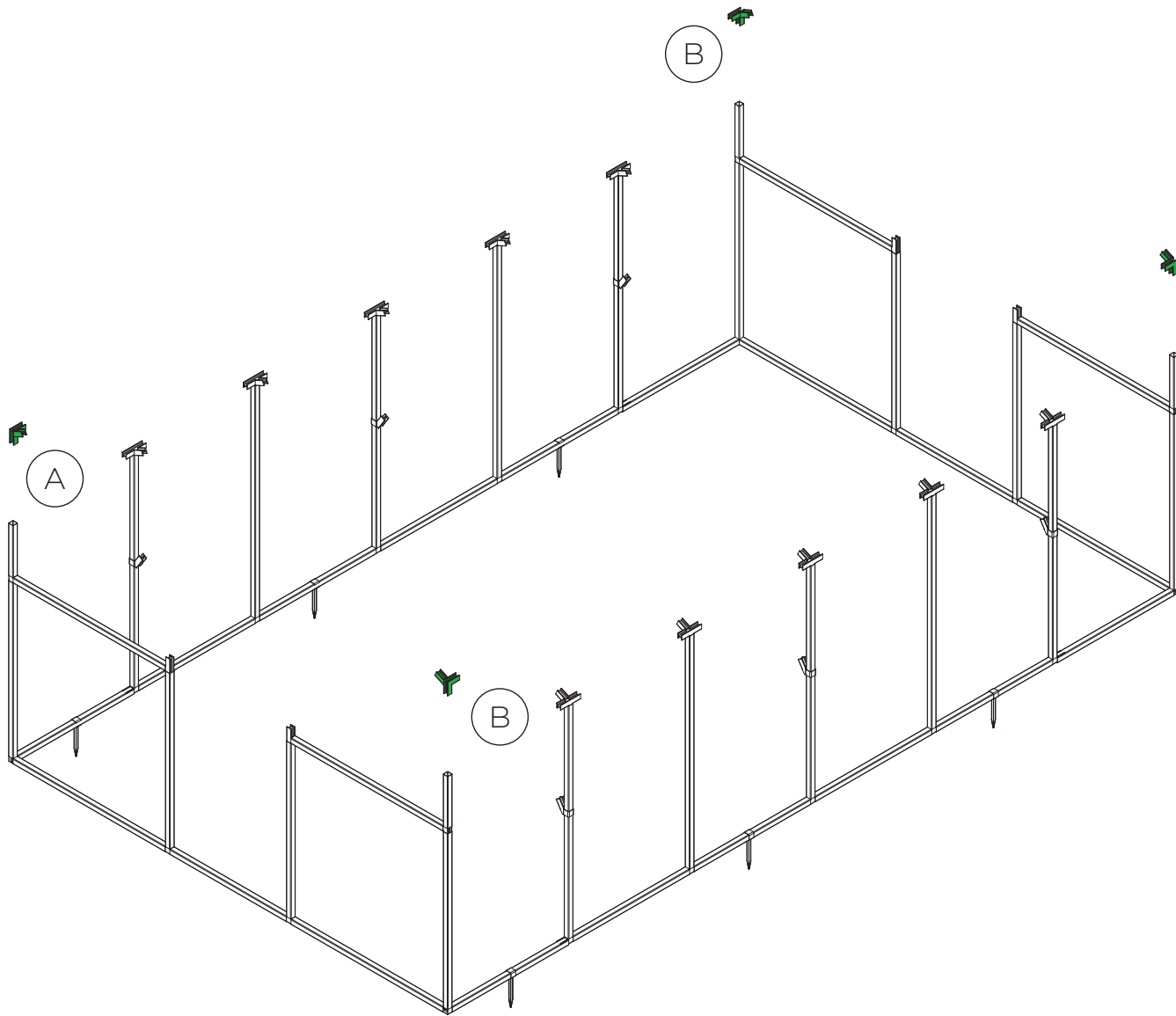

10

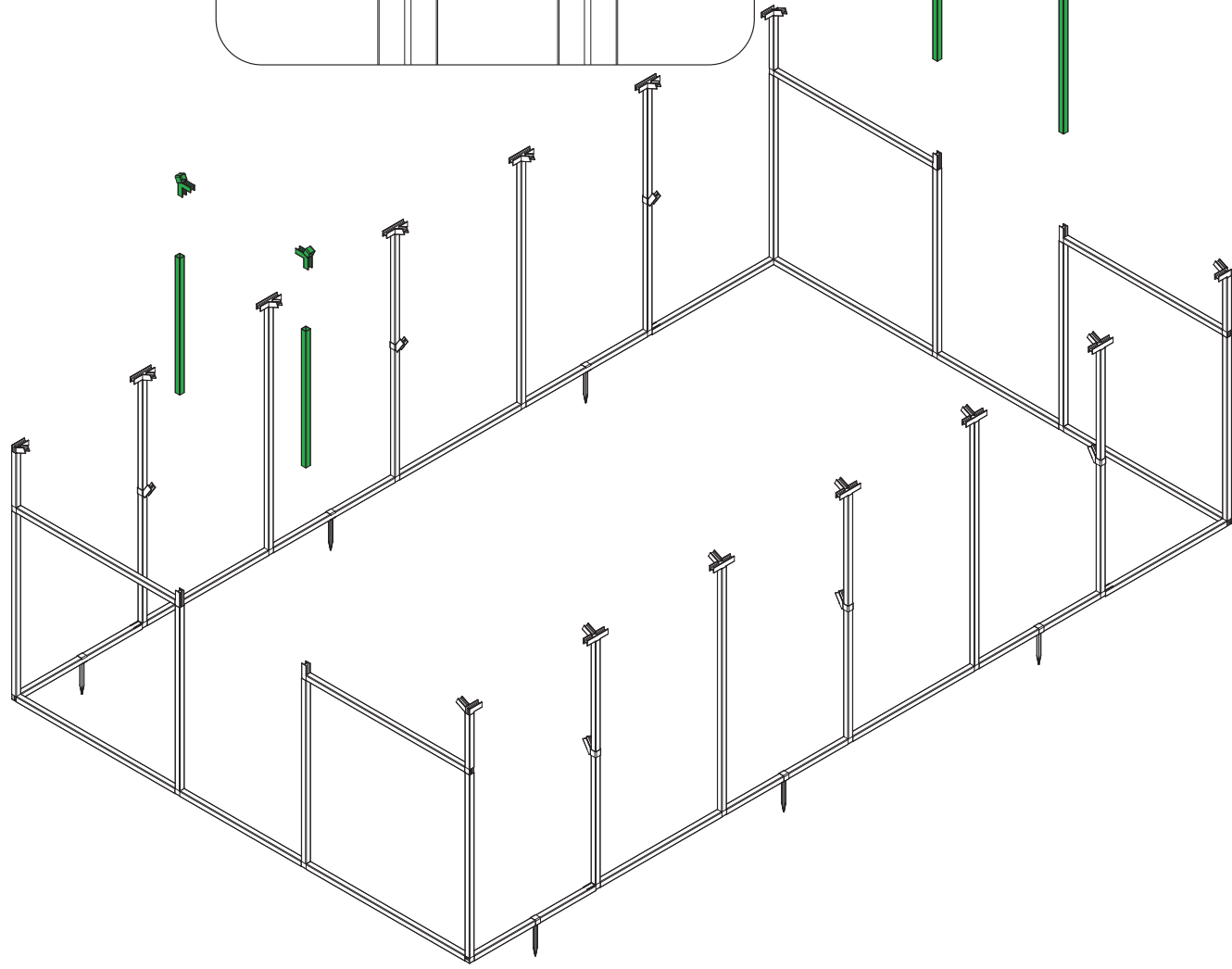
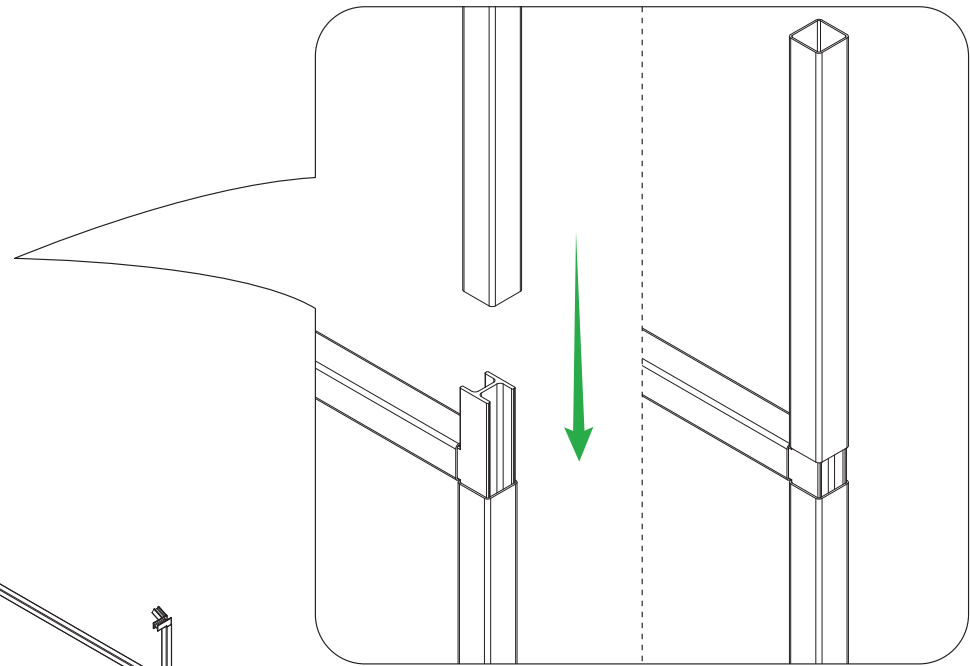
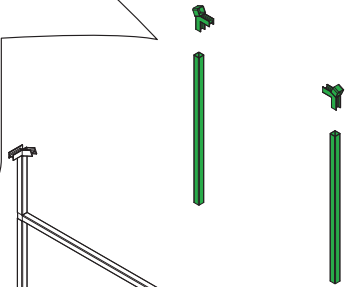
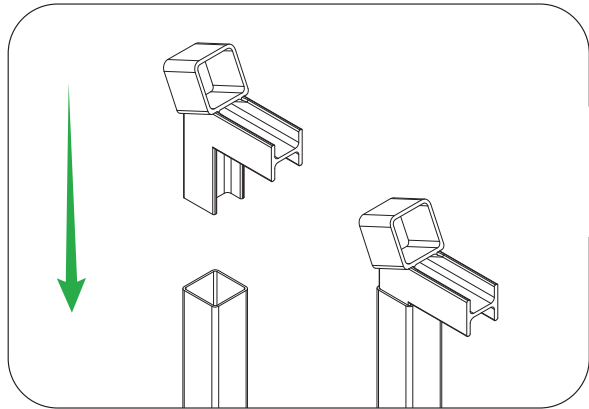

elements

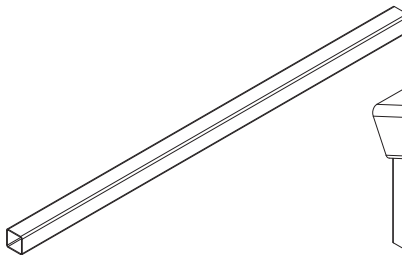

x4 - 730mm
P-03

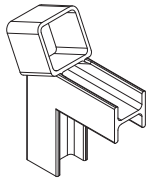

x4
Z-11

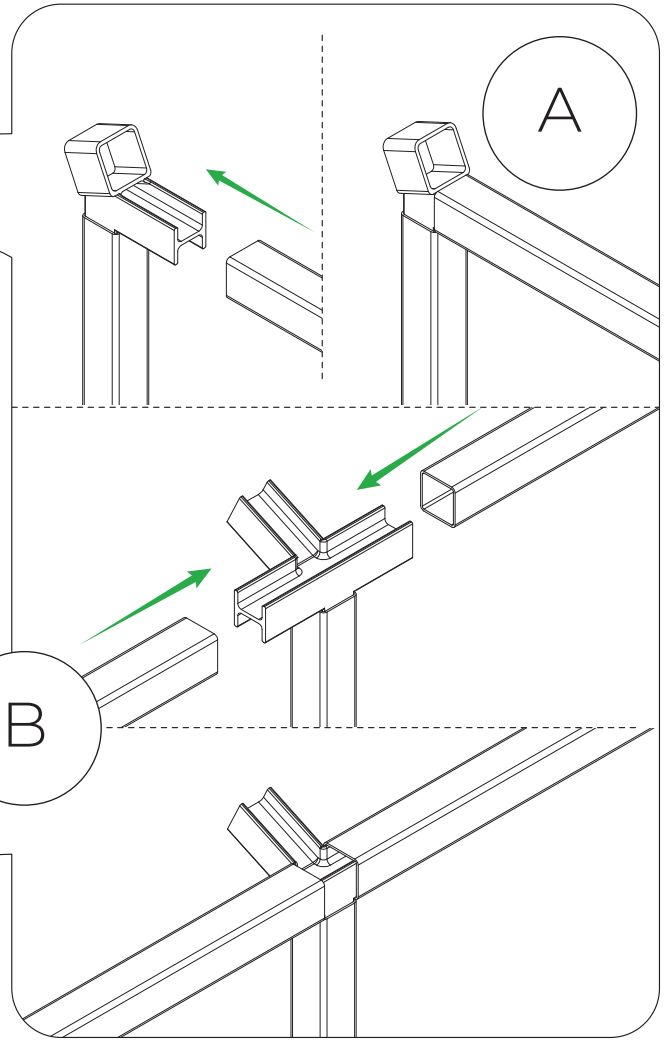
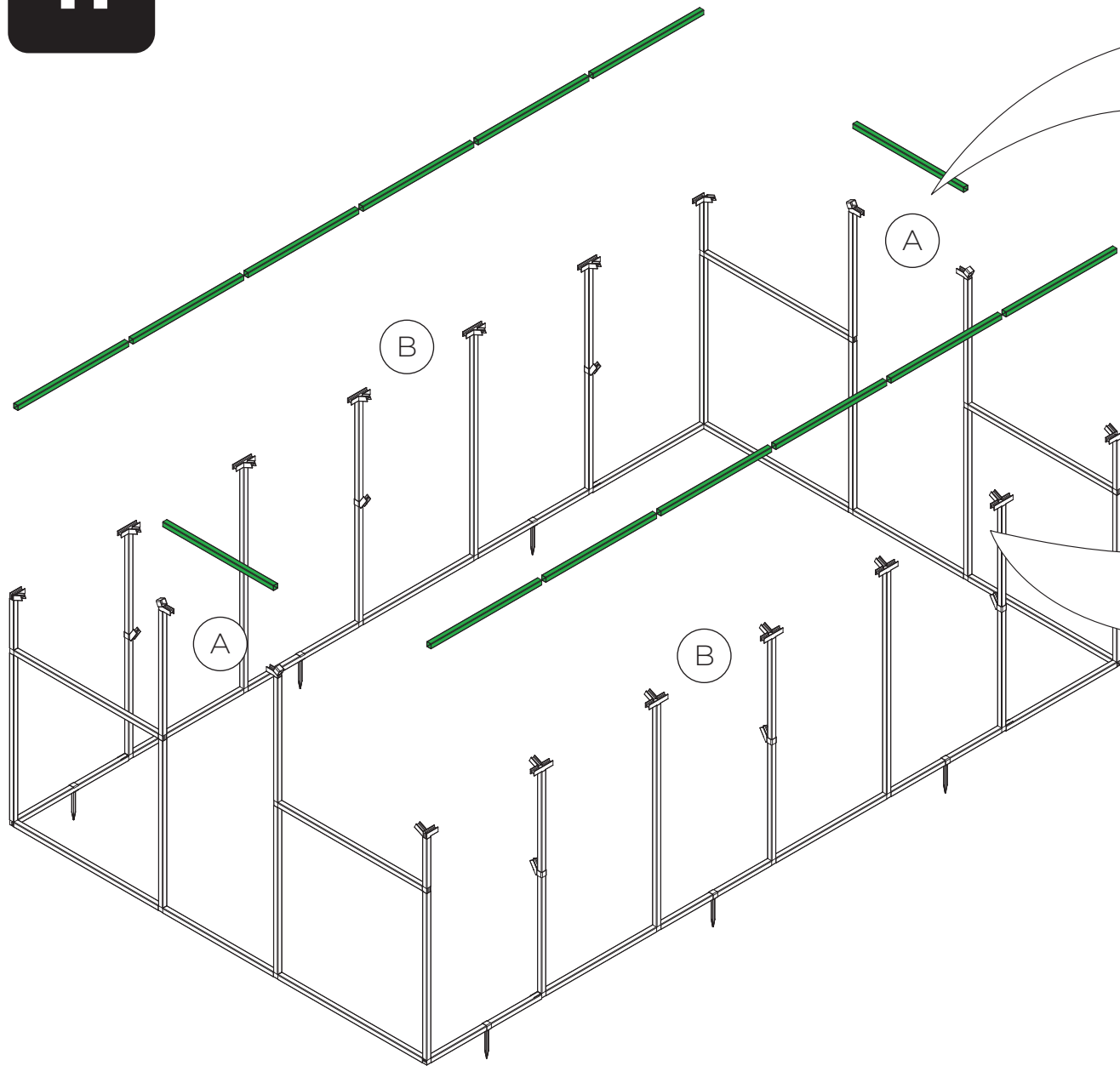

elements

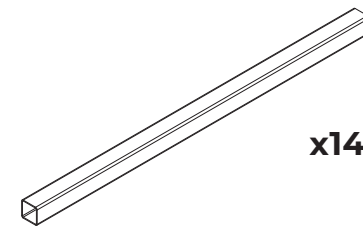

x14 - 750mm
P-01

12

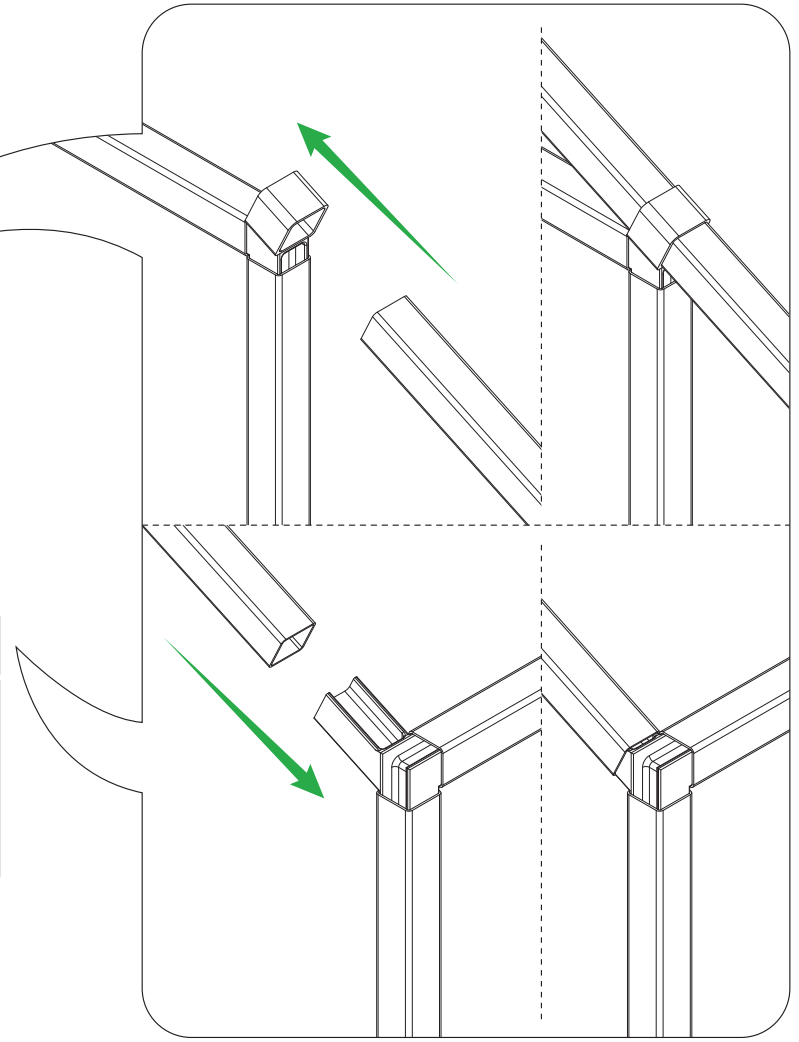
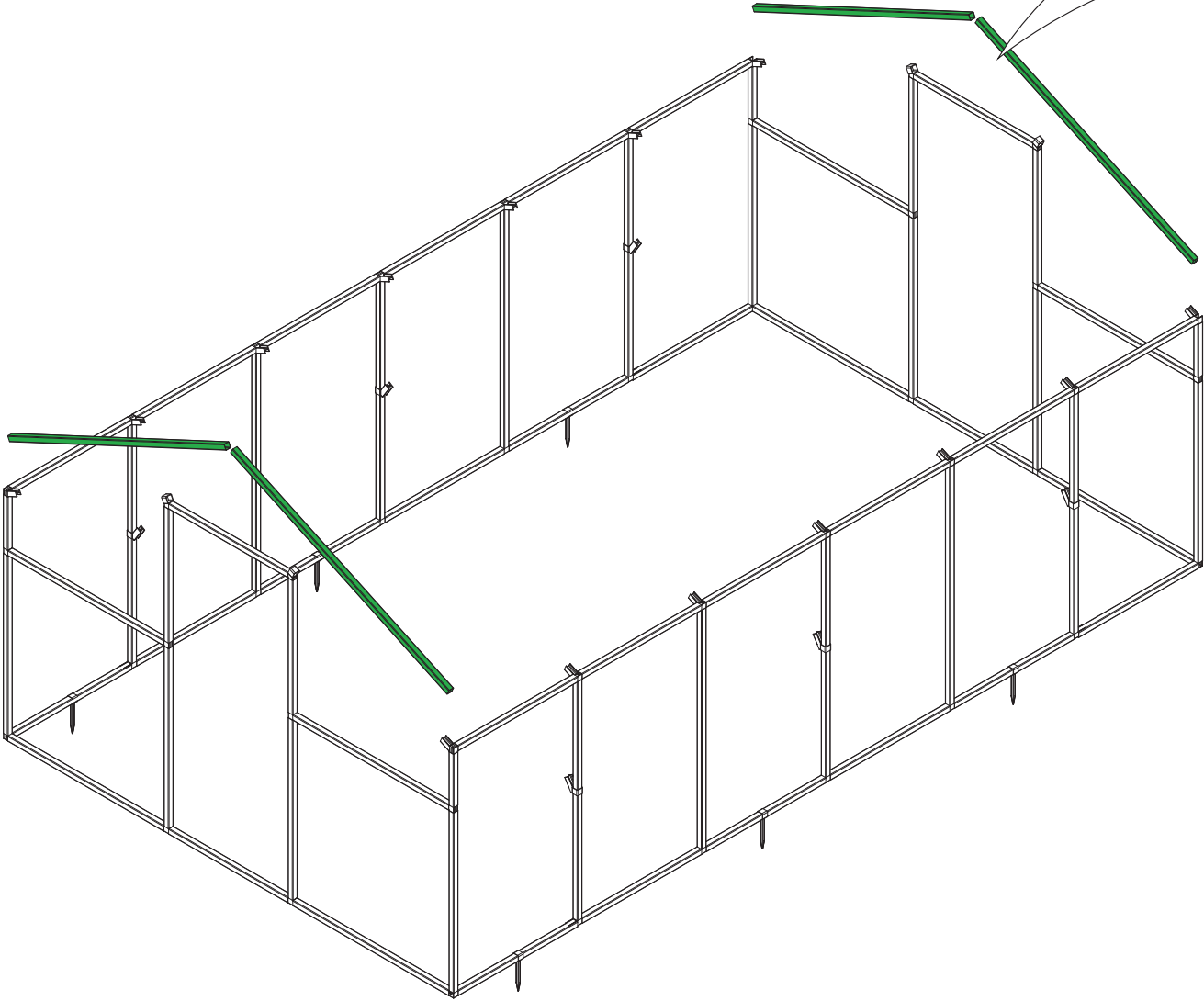

elements

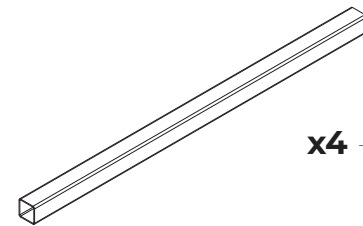

x4 - 1500mm
P-10

13

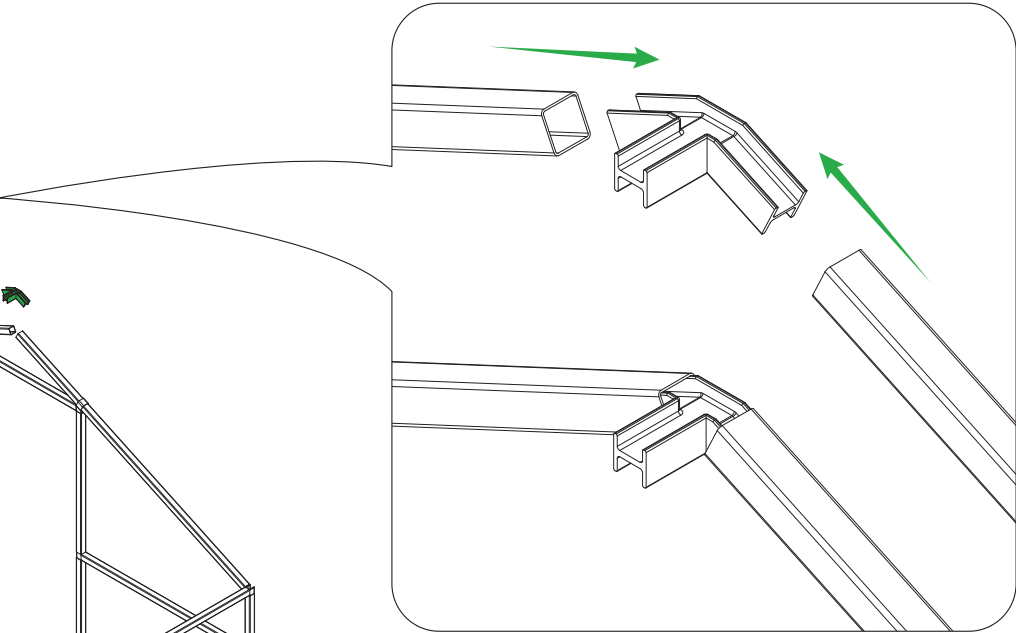
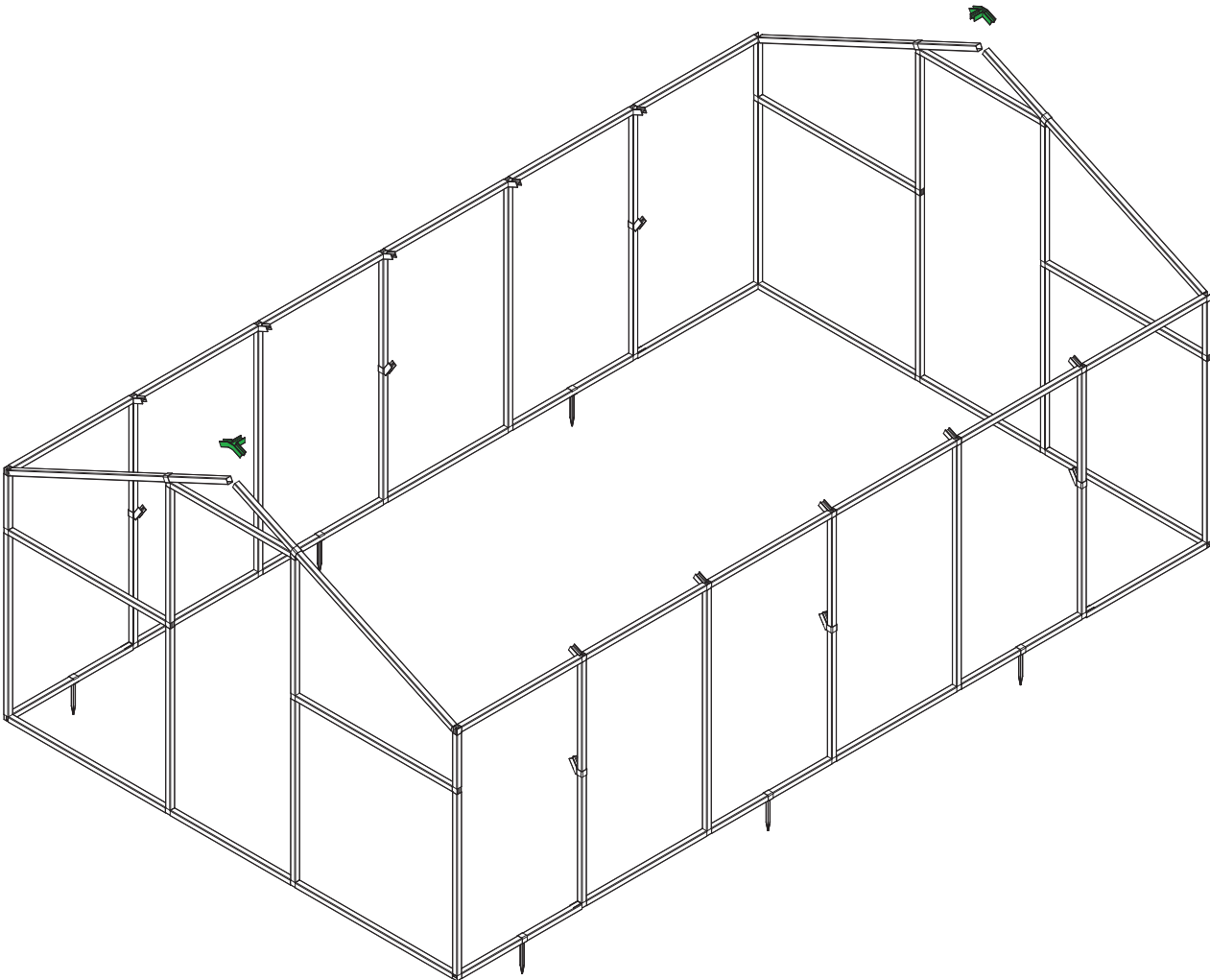

elements

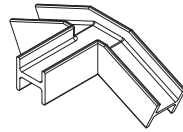

x2
Z-09

14

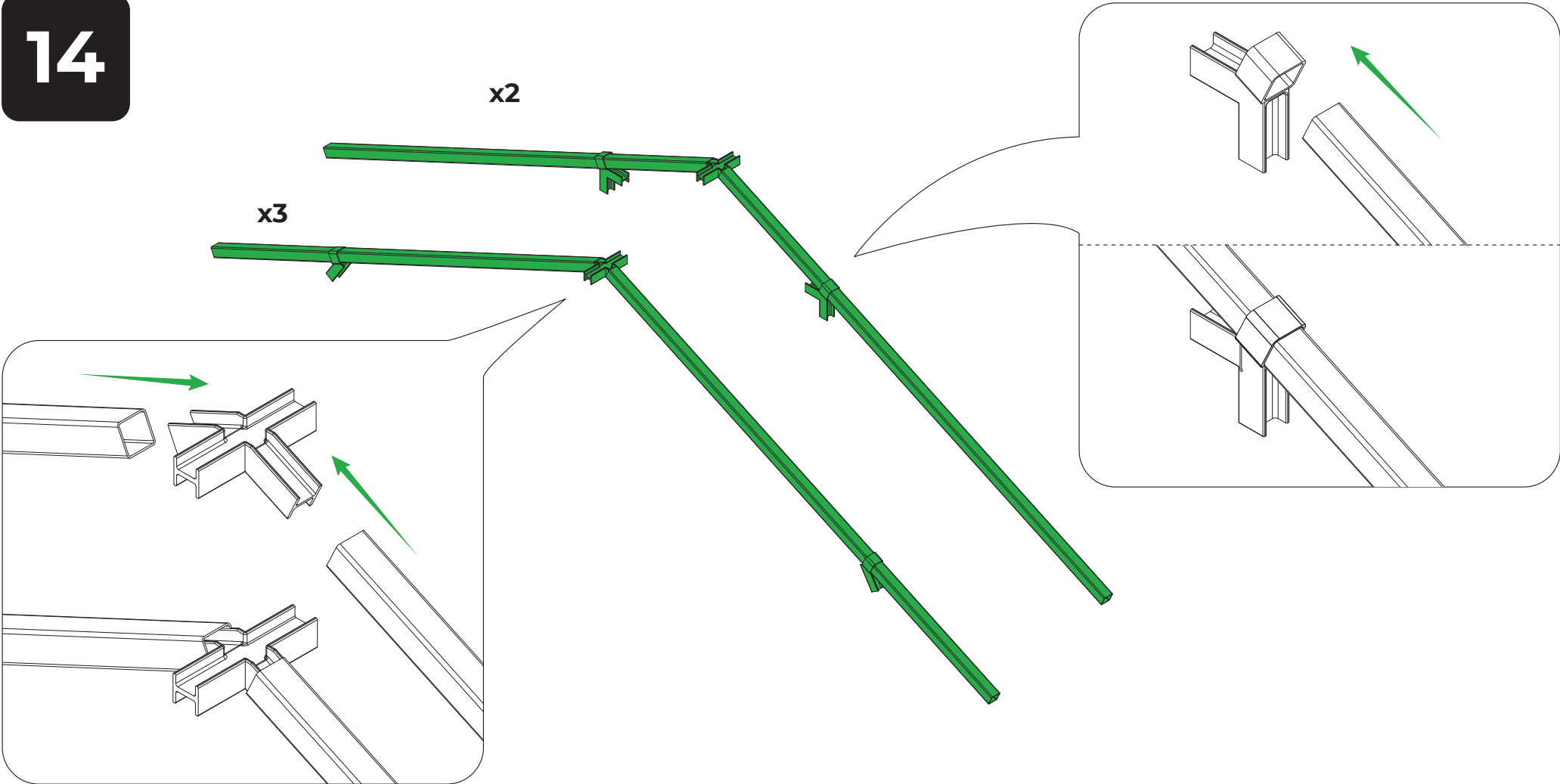

elements

The elements list contains four items:

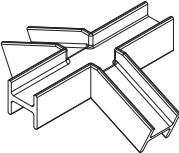
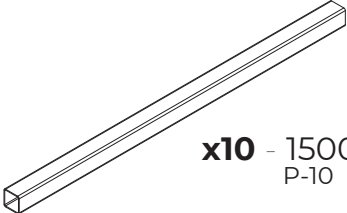
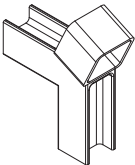
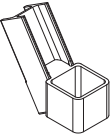
-  **x5**
Z-10
-  **x10** - 1500mm
P-10
-  **x4**
Z-11
-  **x6**
Z-11A

15

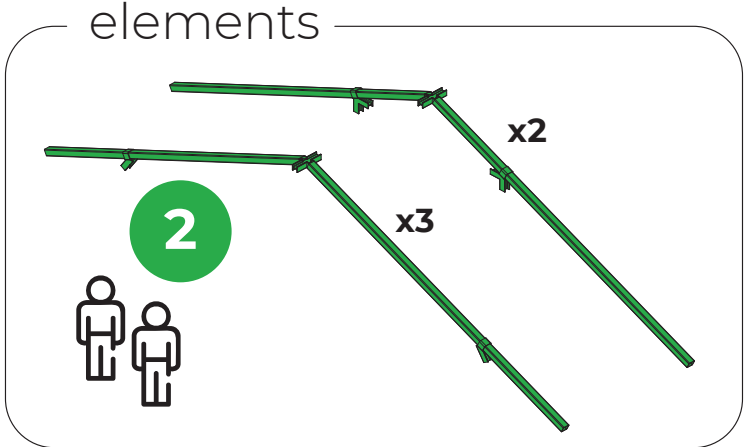
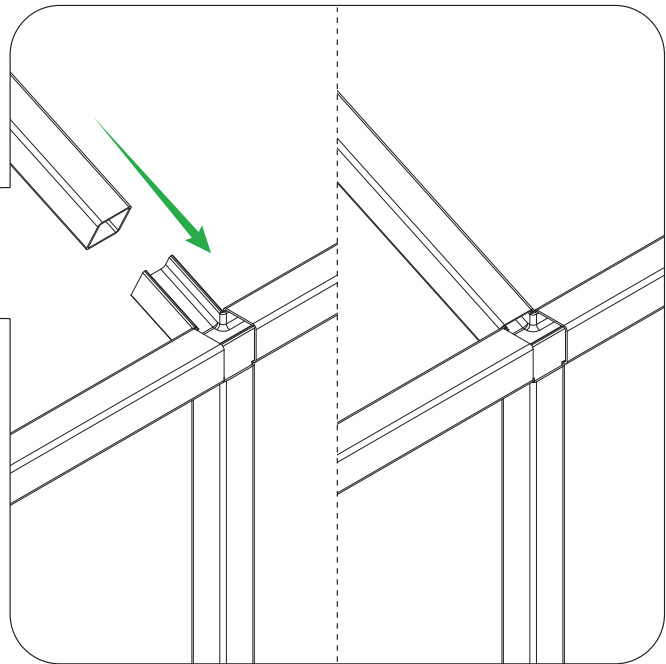
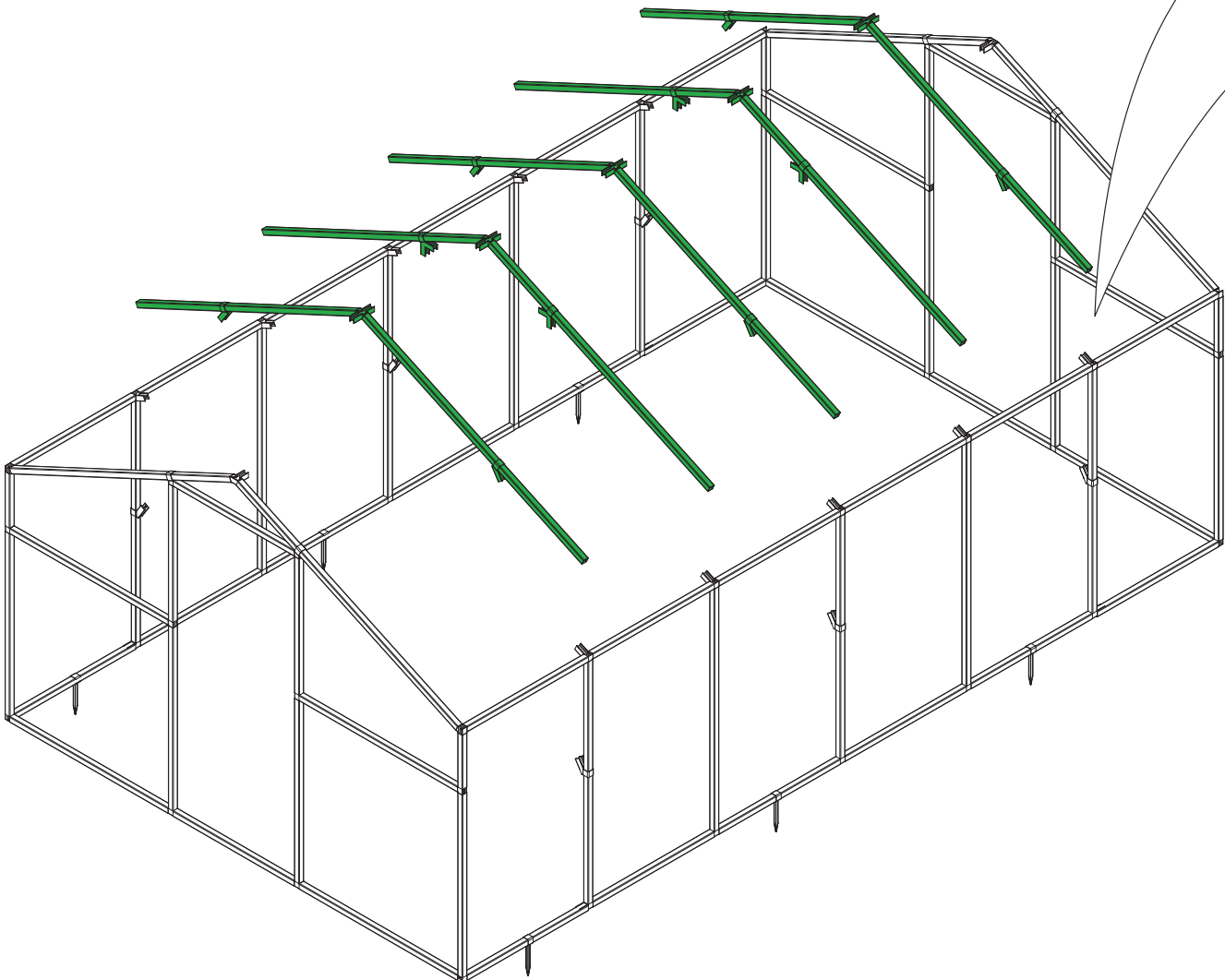

16

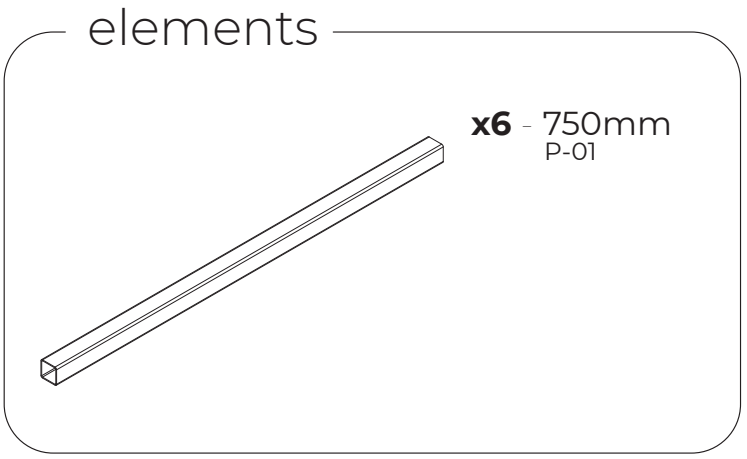
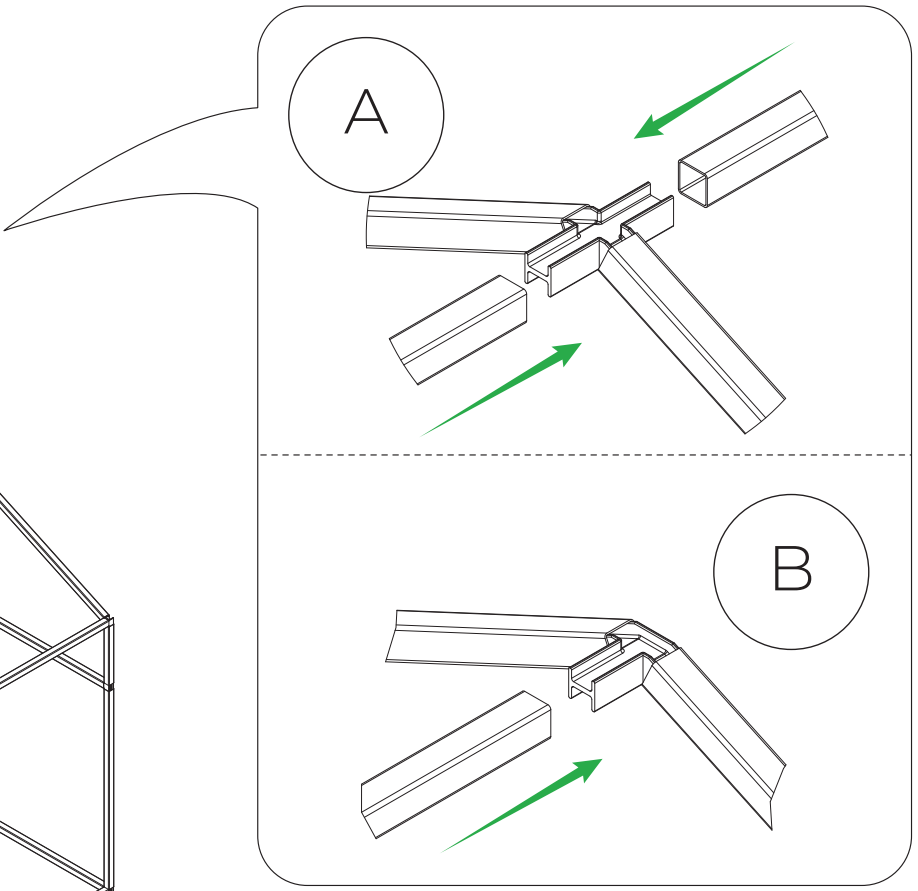
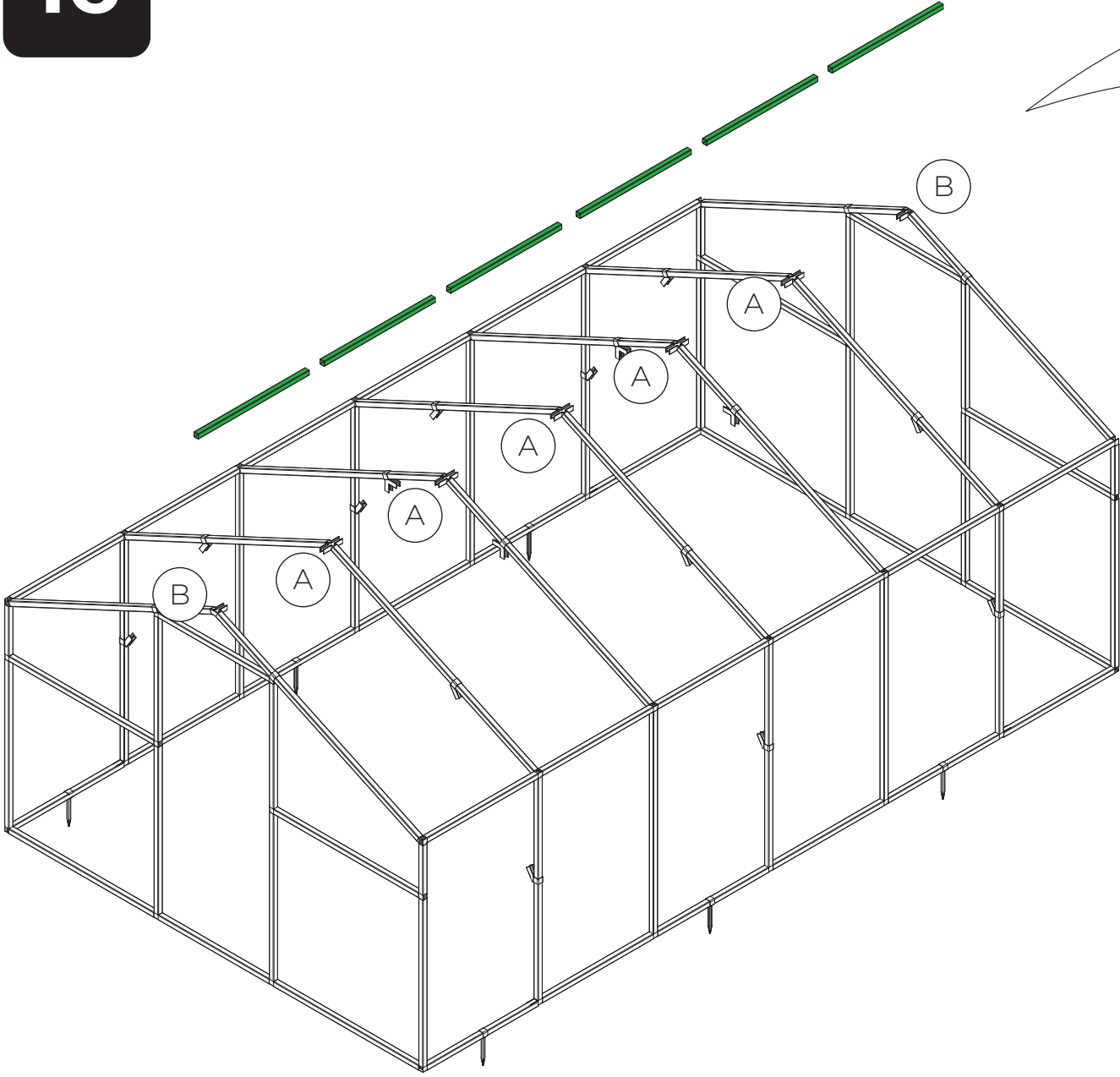

17

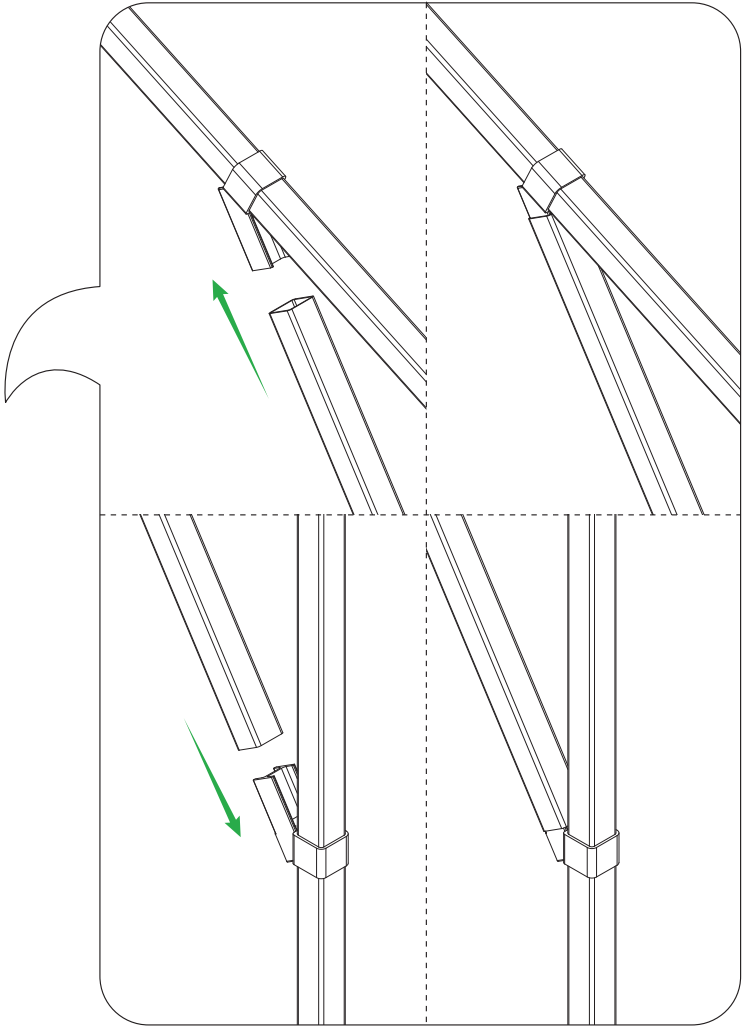
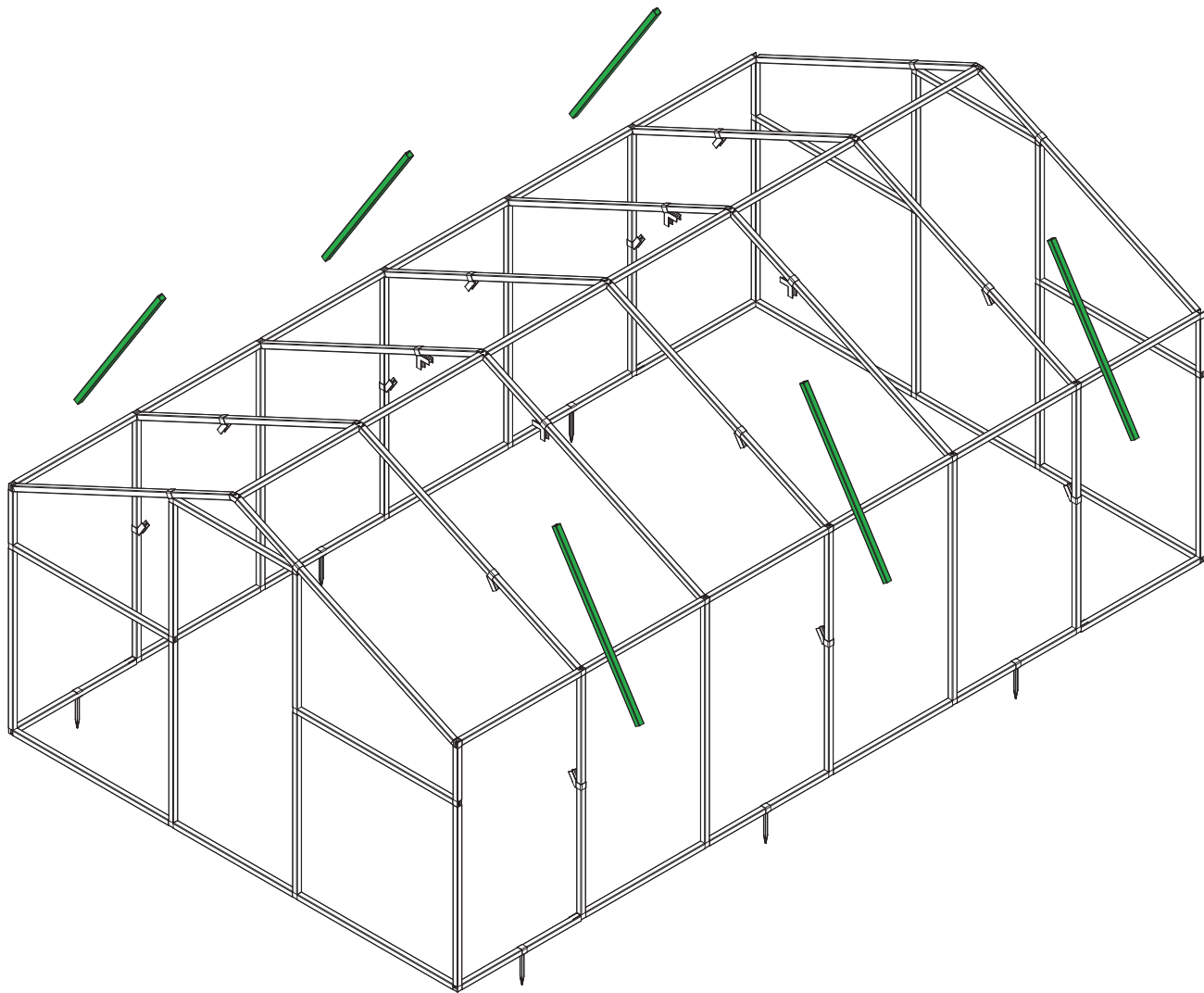

elements

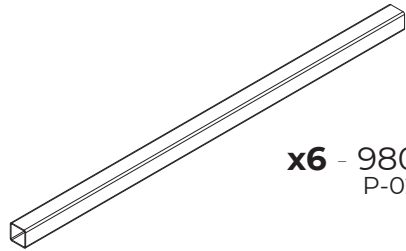

x6 - 980mm
P-02

18

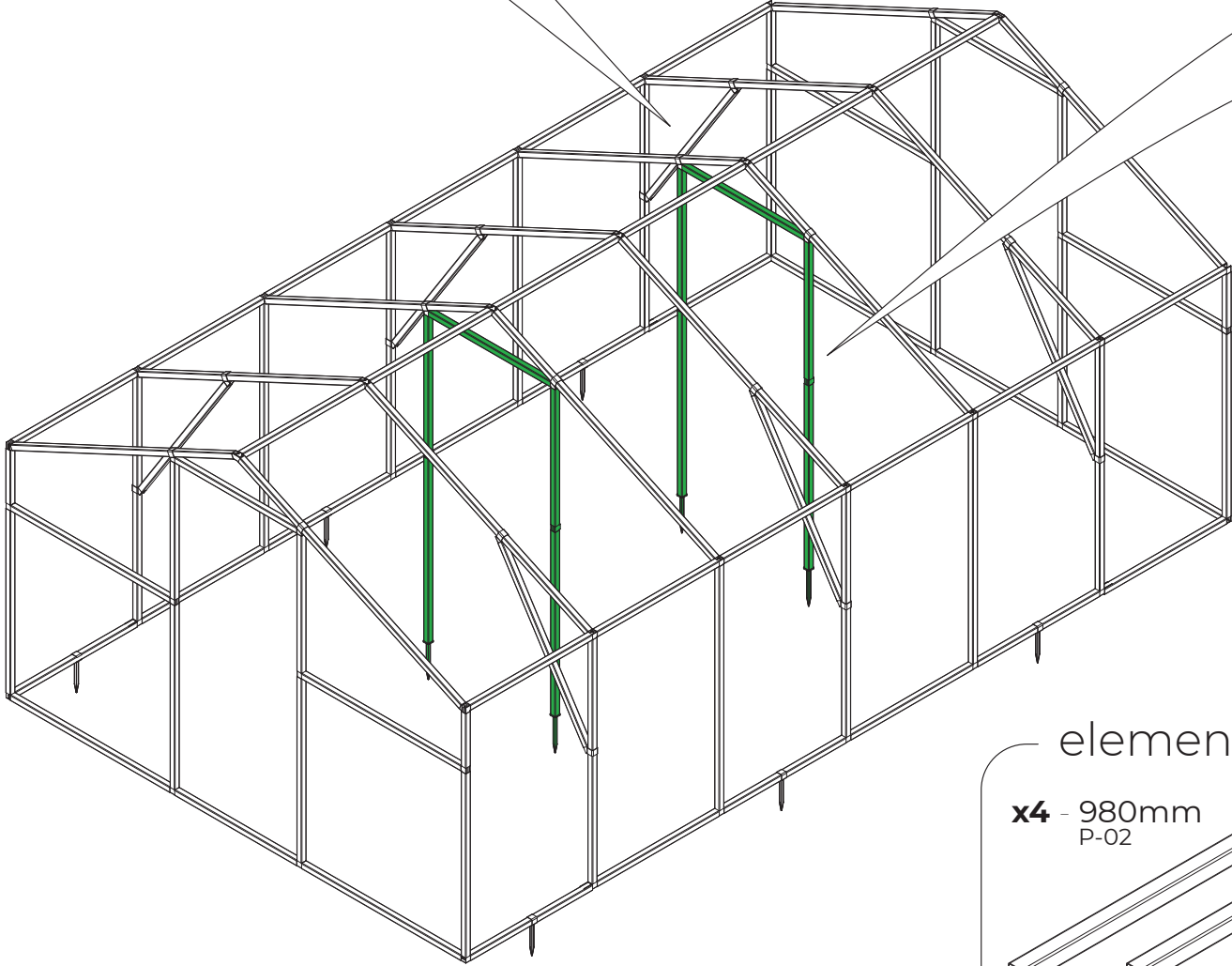
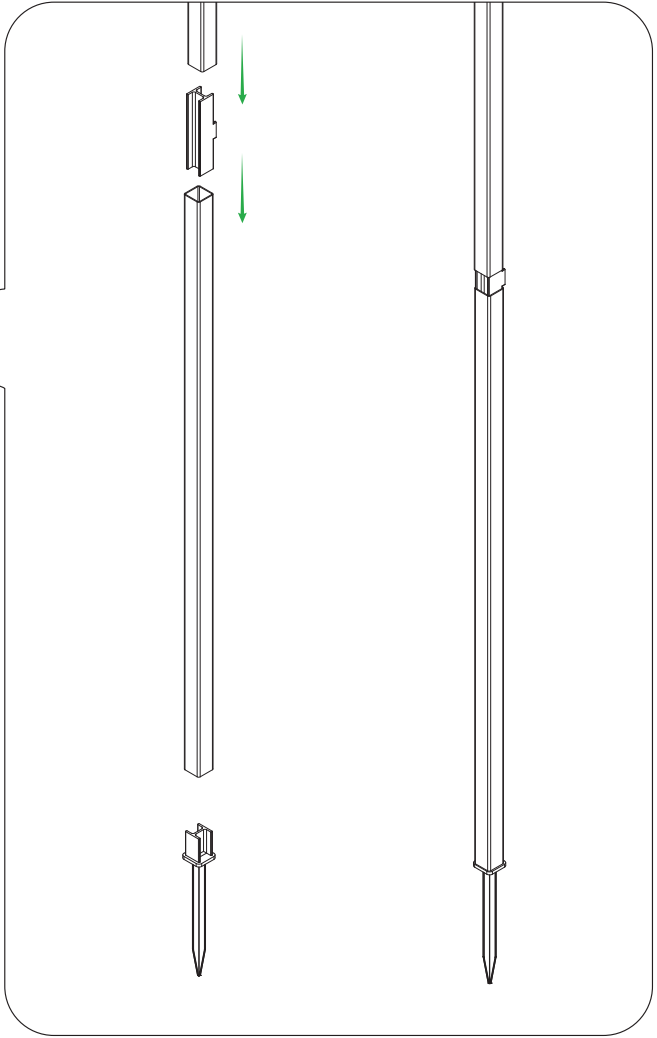
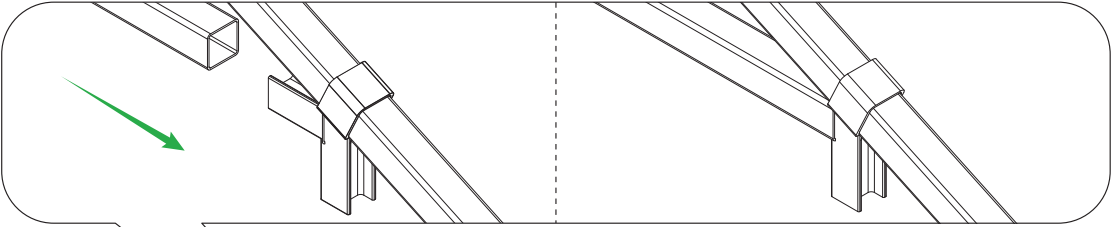

elements

x4 - 980mm
P-02

x2 - 750mm
P-01

x4 - 730mm
P-03

x4
Z-15

x4
SZ-2

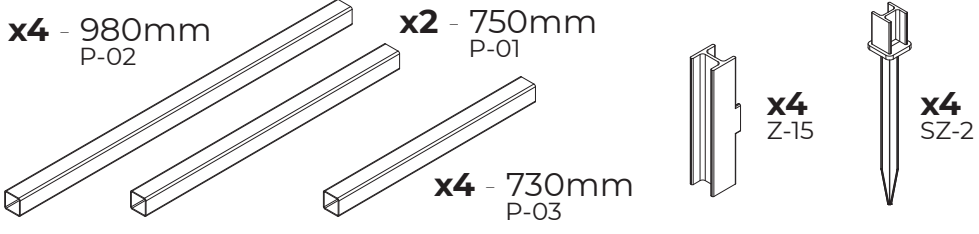

19



EN All the profiles and connectors of the foil greenhouse must be screwed with W1 screws. Do not mount the screws on the external side of the greenhouse to prevent foil damage.
DE Stellen Sie sicher, dass alle Profile und Verbindungsstücke des Foliengewächshauses mittels W1-Schrauben zusammengeschraubt werden. Die Schrauben dürfen nicht an der Außenseite des Gewächshauses angeschraubt werden, um die Folie nicht zu beschädigen.

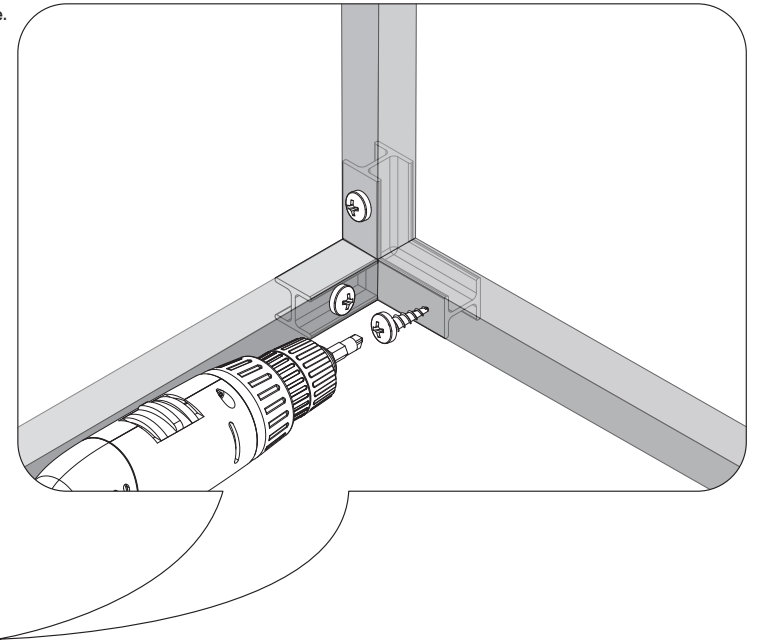
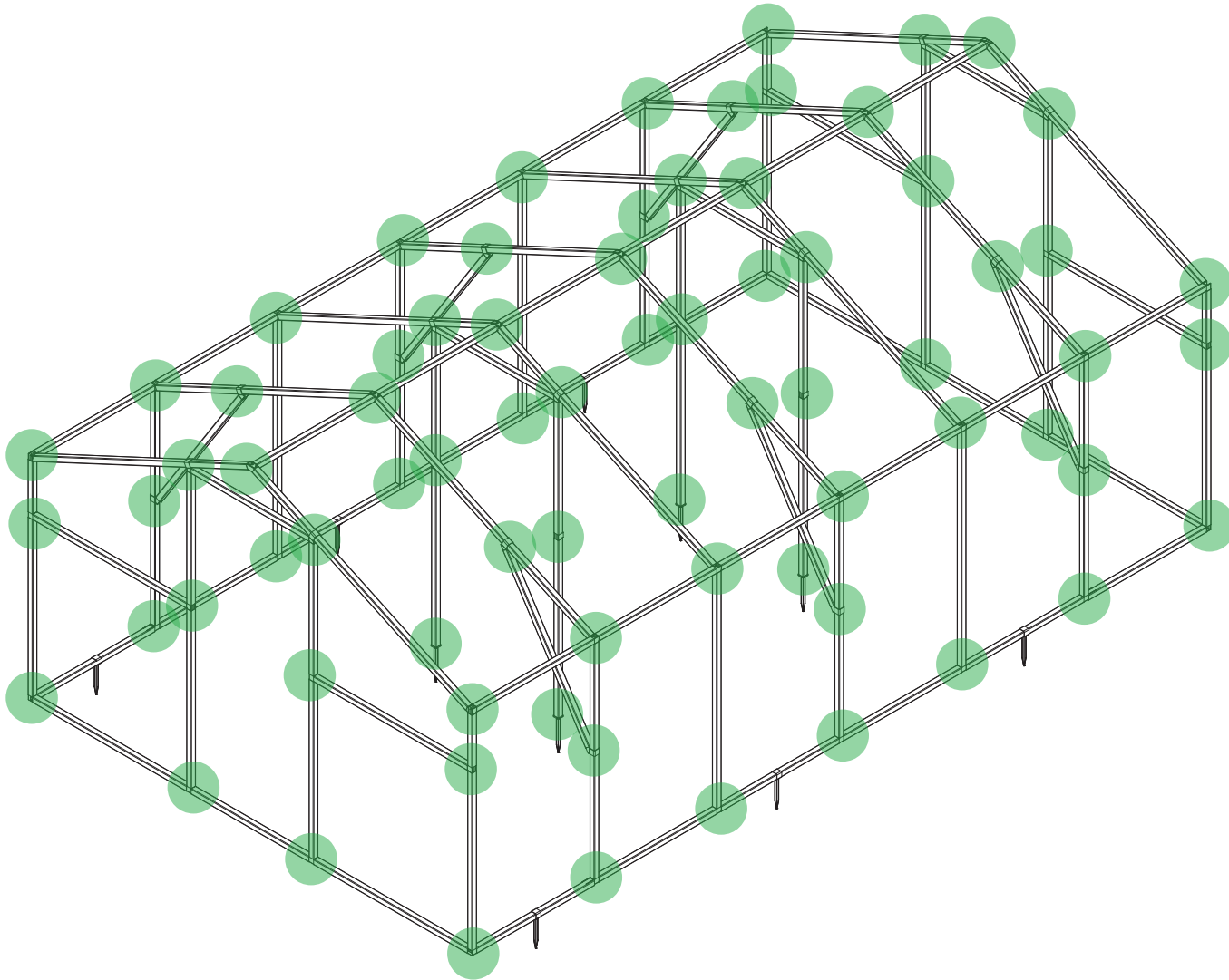

elements

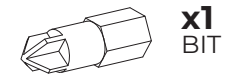

x1
BIT

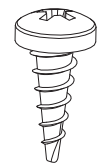

x216
W1

20



EN All Z-14 clips must be fastened with W1 screws from the inside of the greenhouse DO NOT CUT OUT THE FOIL EXCESS! Dig it into the ground at the depth of 40 cm. The foil should be folded in the ground.
DE Alle Clips Z-14 sollten mittels W1- Schrauben von der Innenseite des Gewächshauses montiert werden. DAS ÜBERMAß AN FOLIE NICHT ABSCHNEIDEN! Graben sie es bis zu einer Tiefe von 40 cm in den Boden. Die Folie sollte in den Boden eingezogen werden.

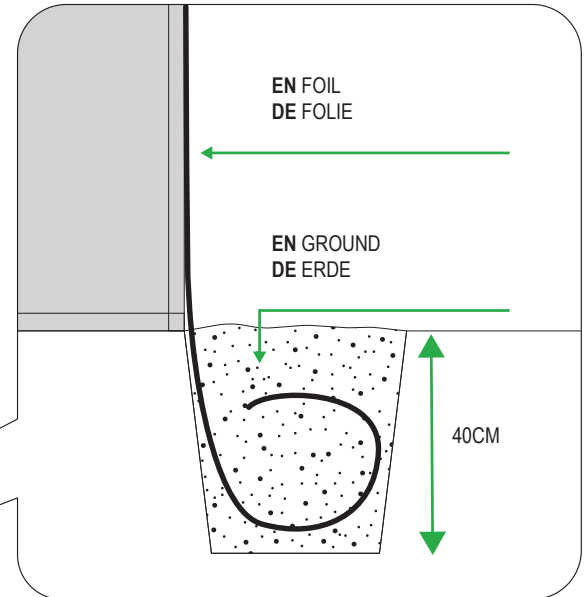
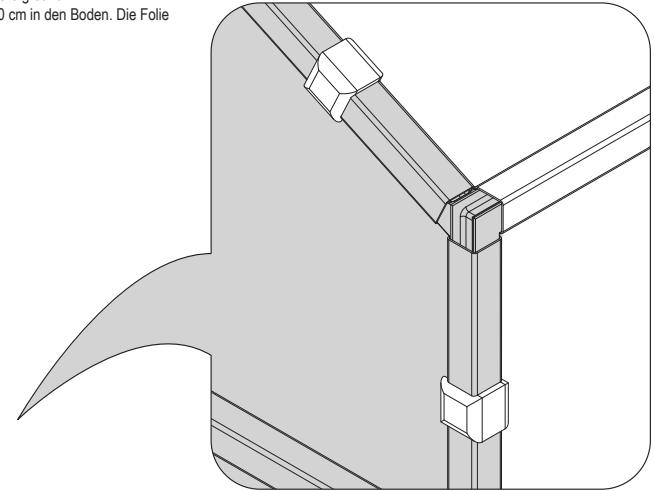
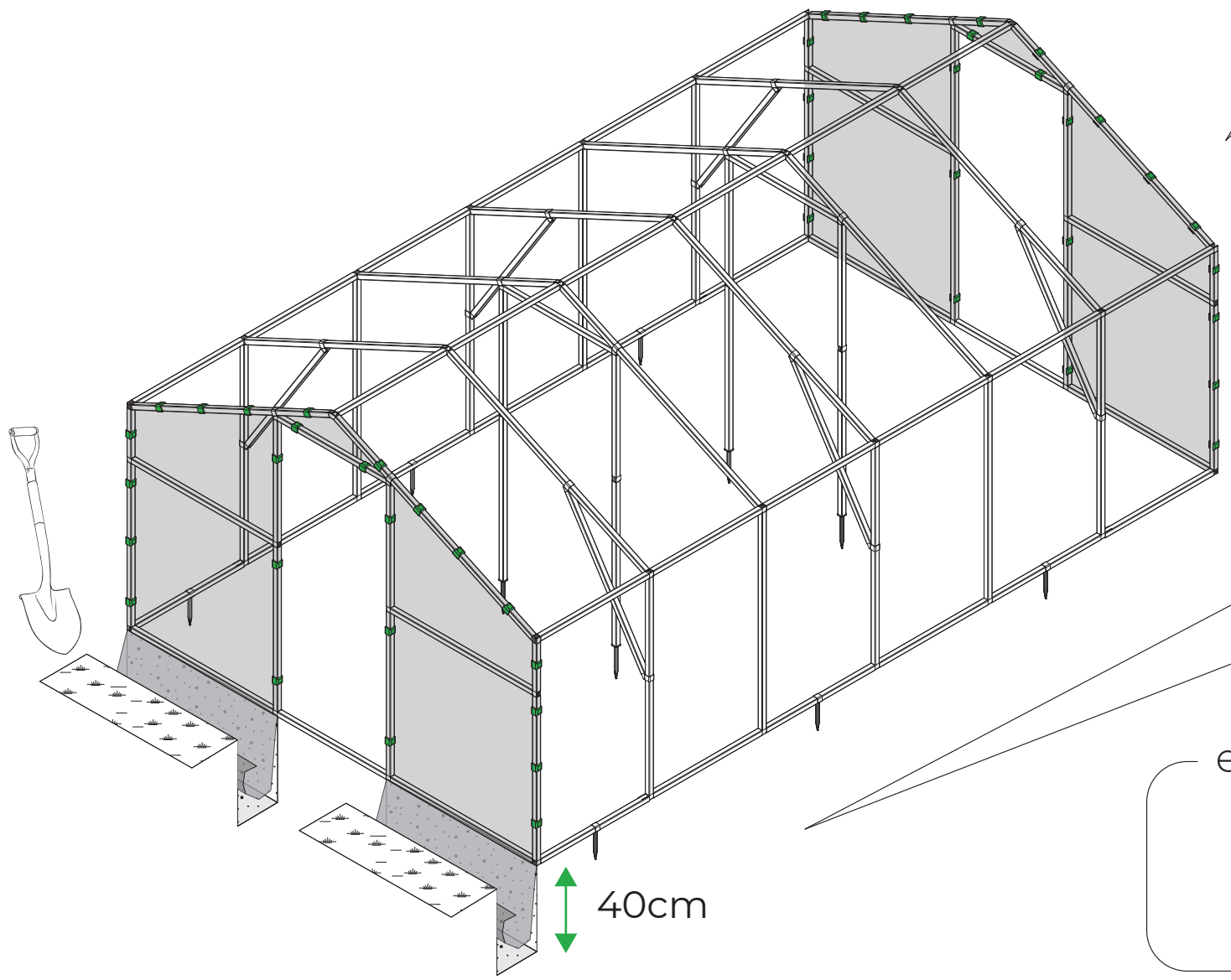

elements



x2
FOIL 2



x48
Z-14

21

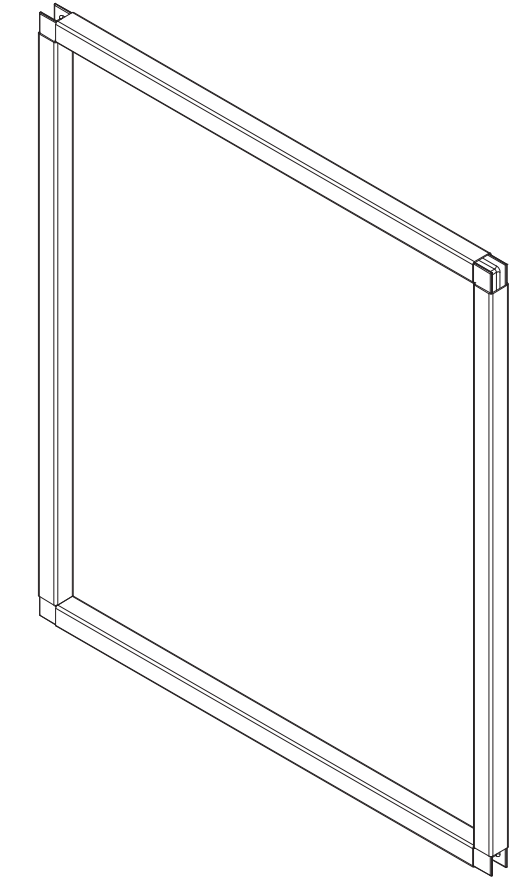
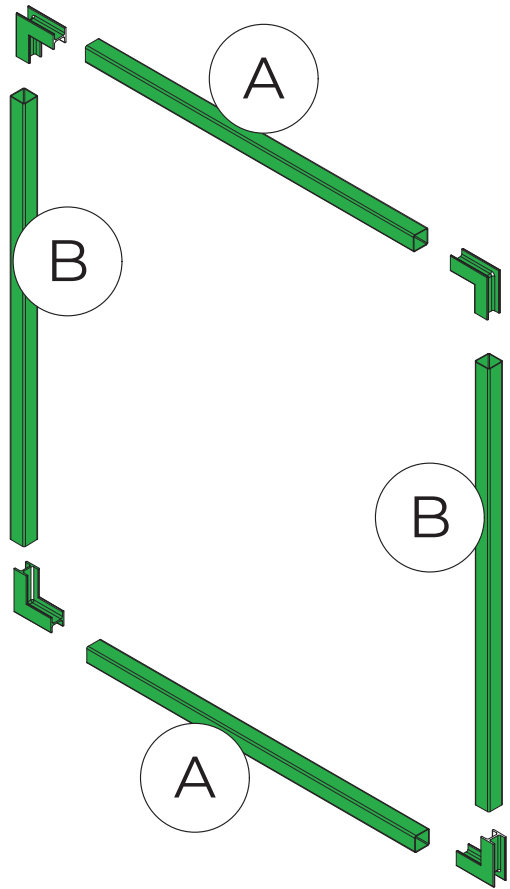

x4

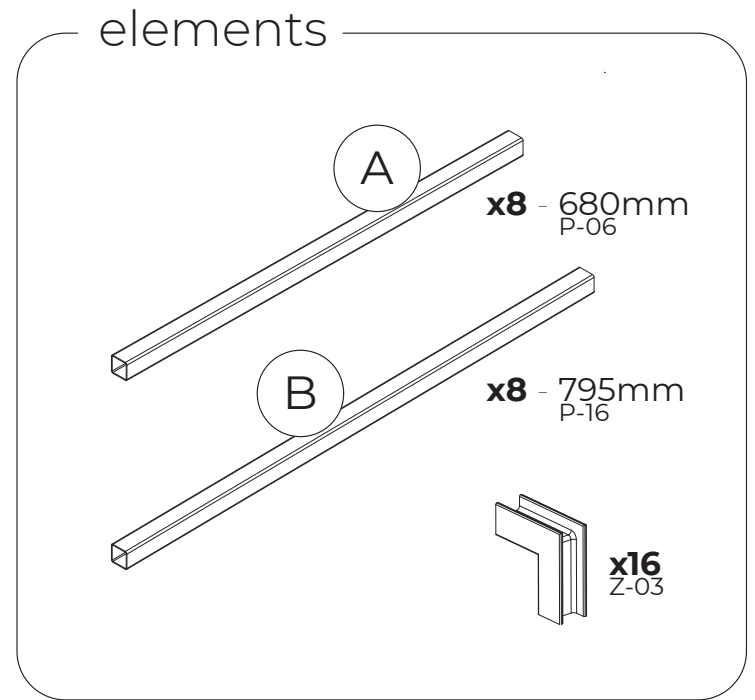
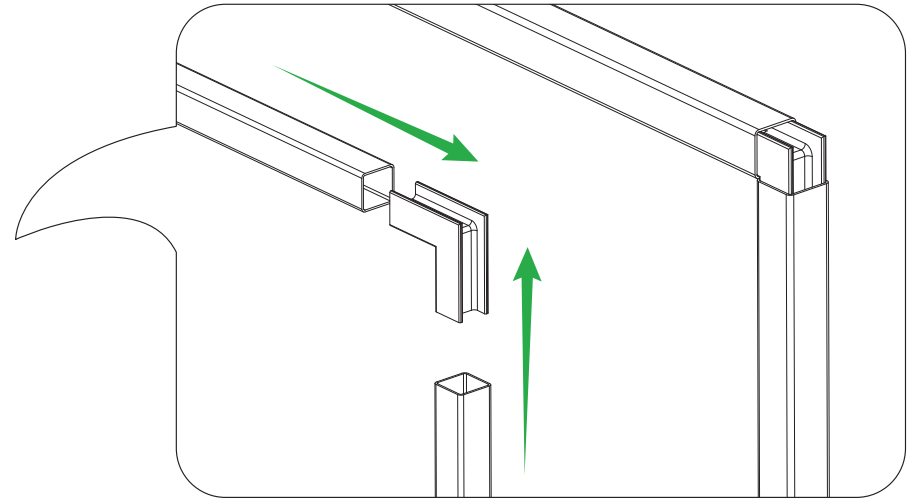

EN Connect the profiles and connectors by means of W1 screws.
DE Verbinden von Profilen und Verbindungsstücken mittels W1-Schrauben.

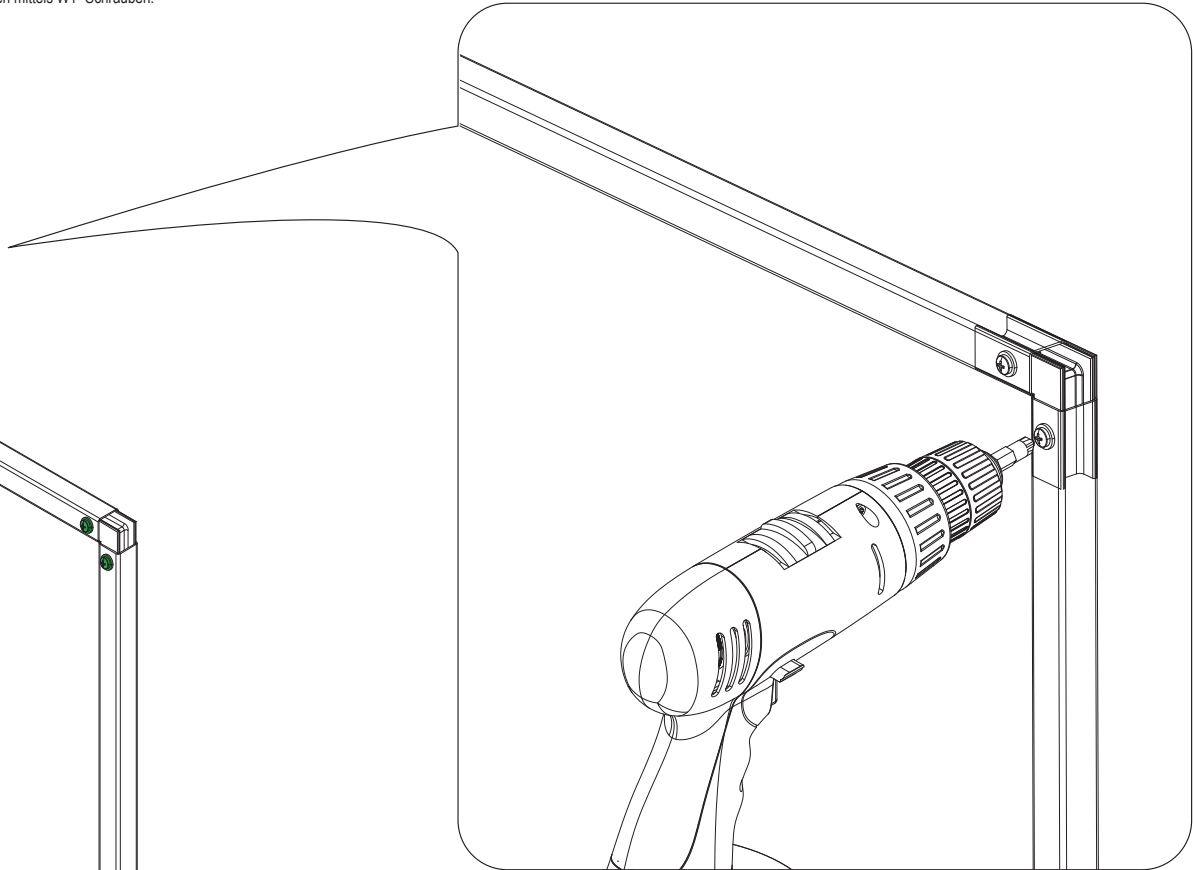
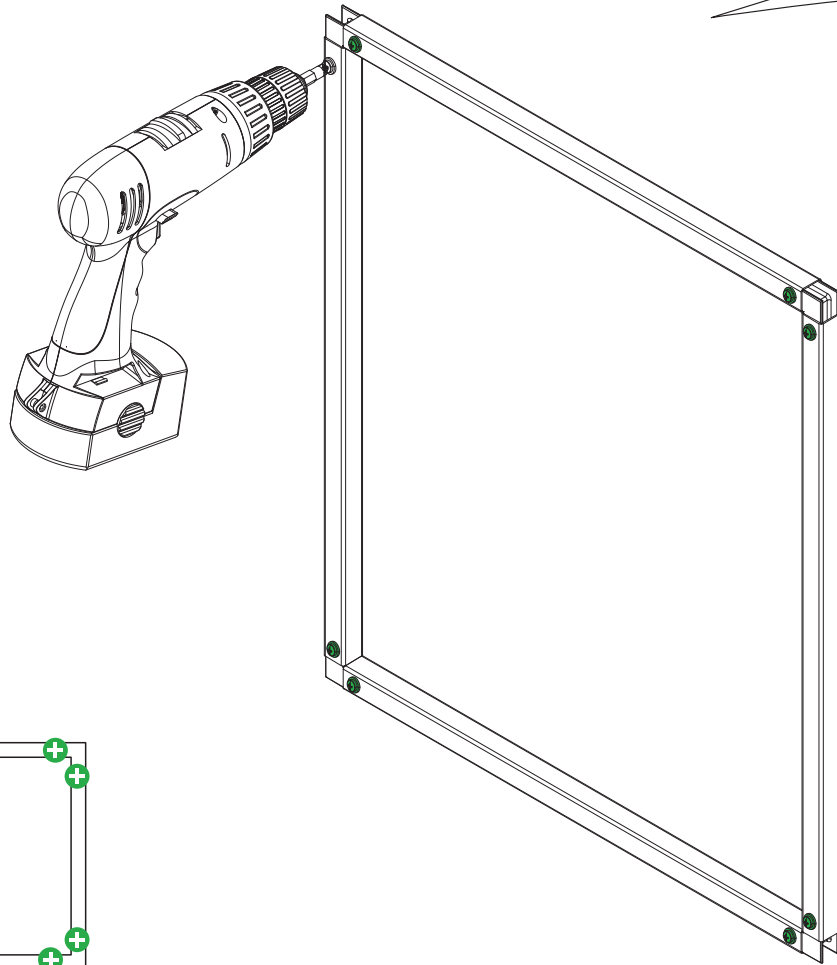

x4

elements

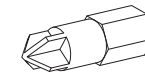

x1
BIT

x32
W1



23



EN All Z-14 clips must be fastened with W1 screws from the inside of the tunnel.
DE Alle Clips Z-14 sollten mittels W1-Schrauben von der Innenseite des Tunnels montiert werden.

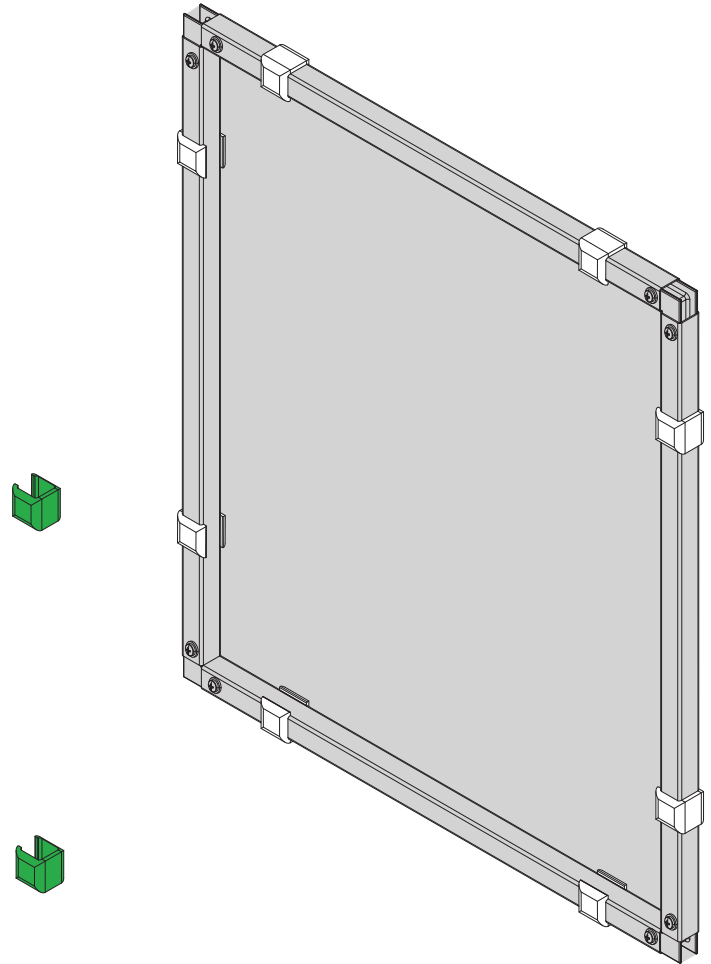
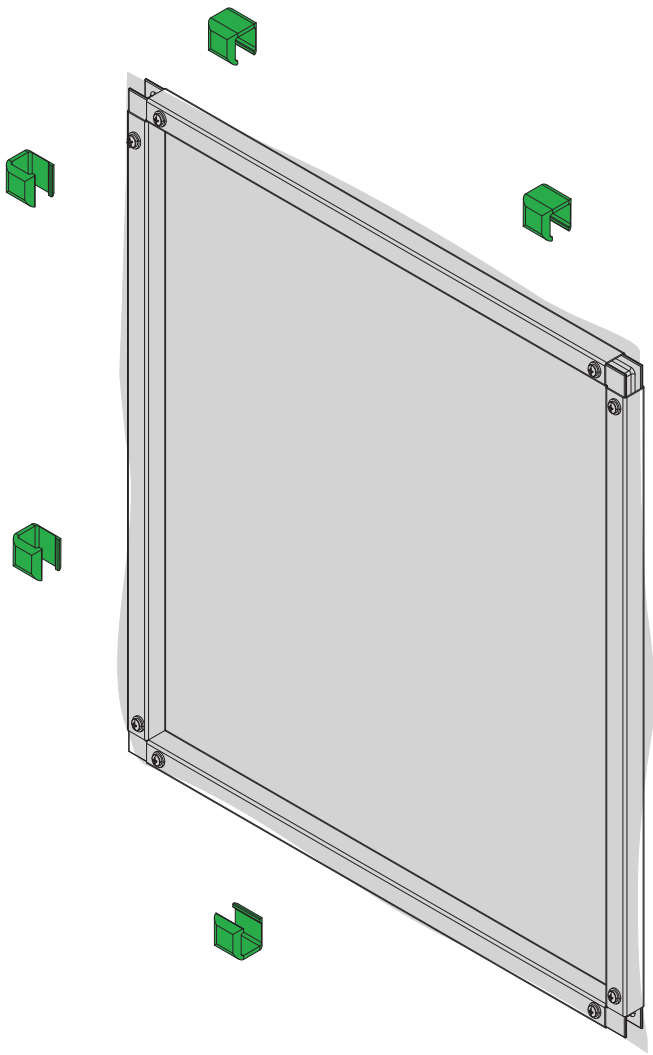

x4

elements

x32
Z-14

x4
FOIL 1

24

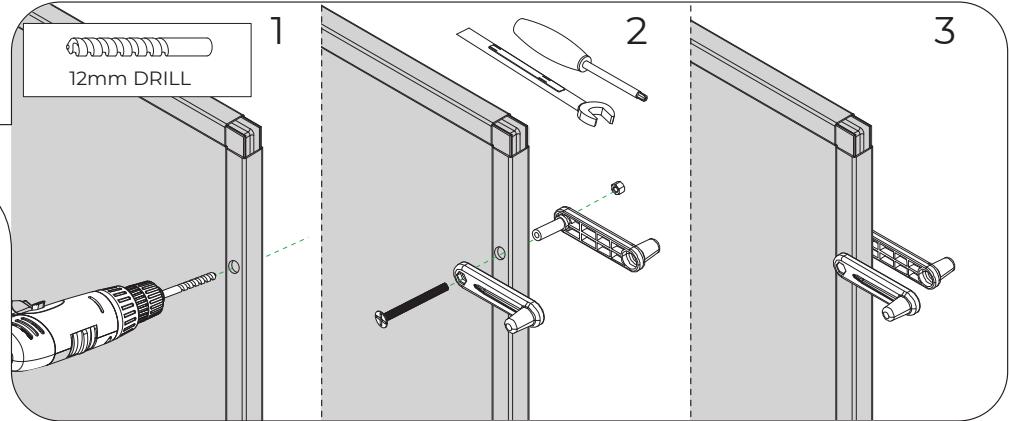
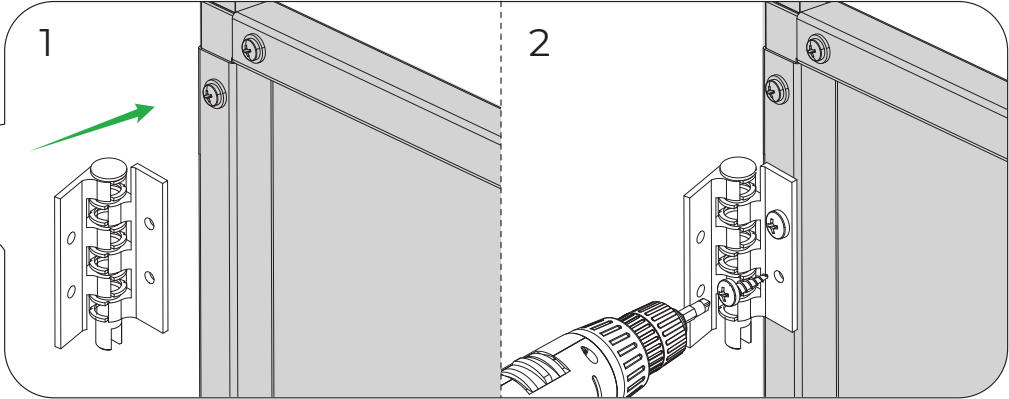
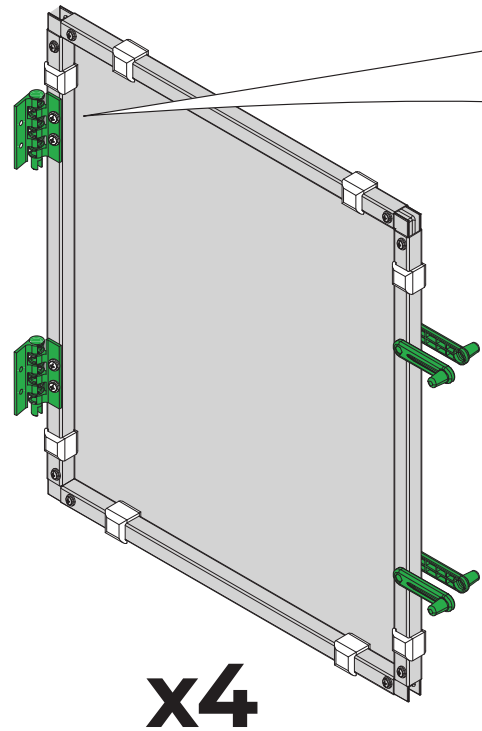
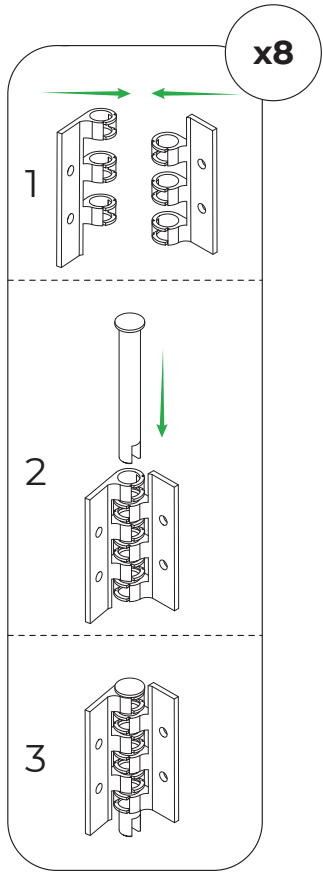

EN Hinge assembly
 DE Zusammensetzen des Scharniers

elements

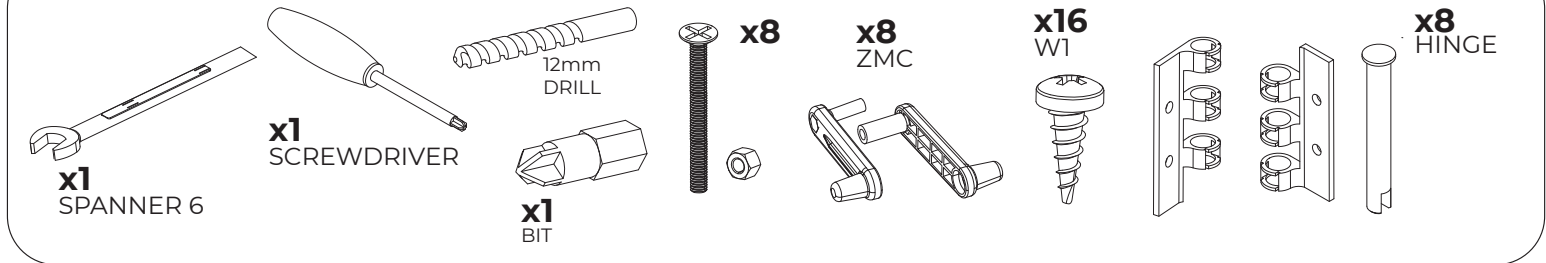

25

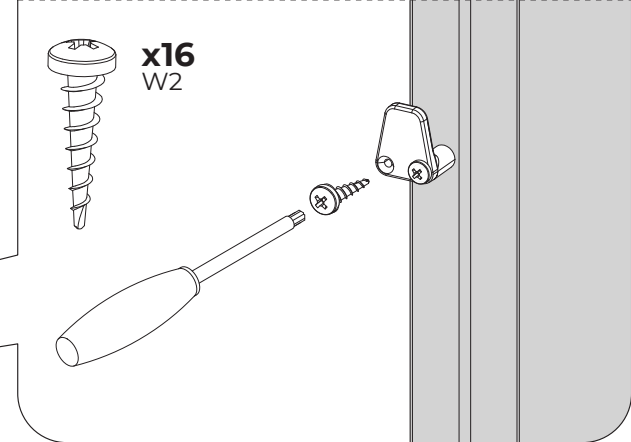
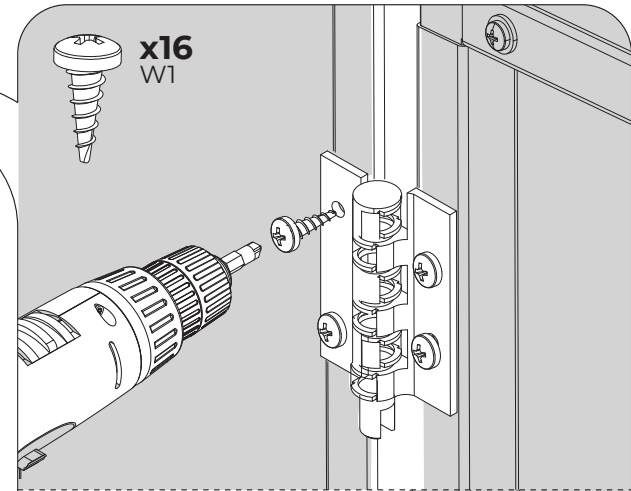
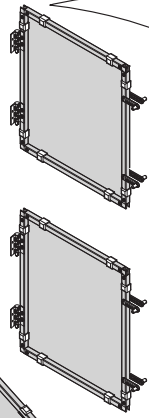
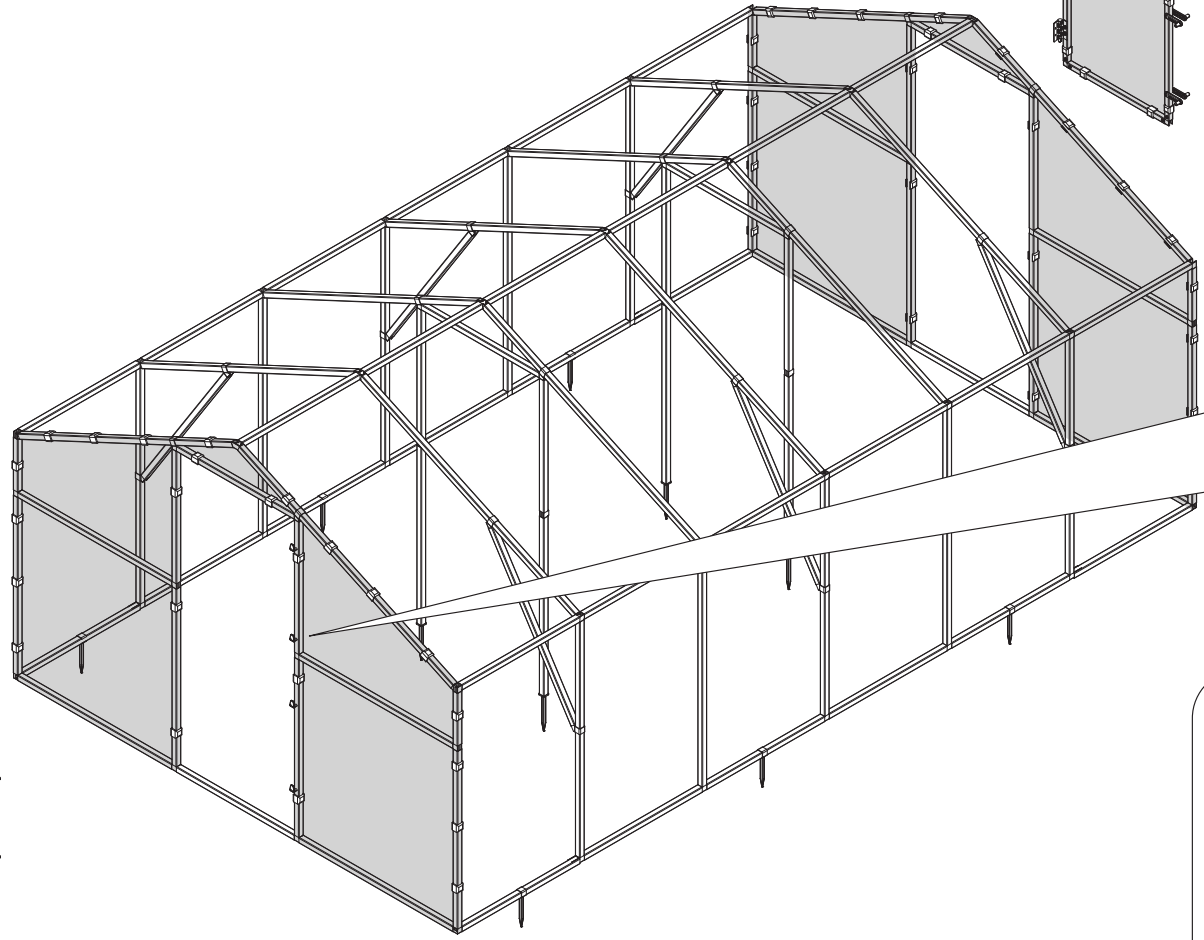
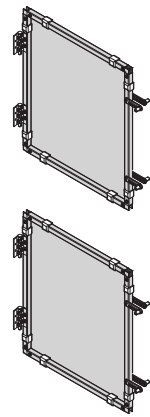

elements

- x8 [Bracket]
- x16 W1 [Screw]
- x16 W2 [Screw]
- x1 SCREWDRIVER [Screwdriver]
- x1 BIT [Bit]
- x4 [Panel]

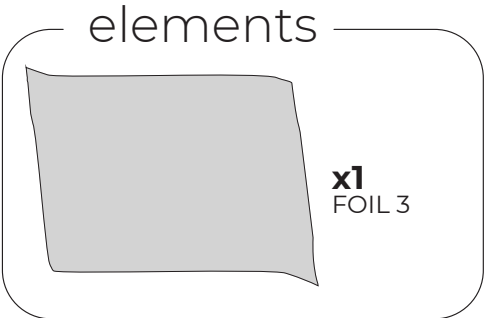
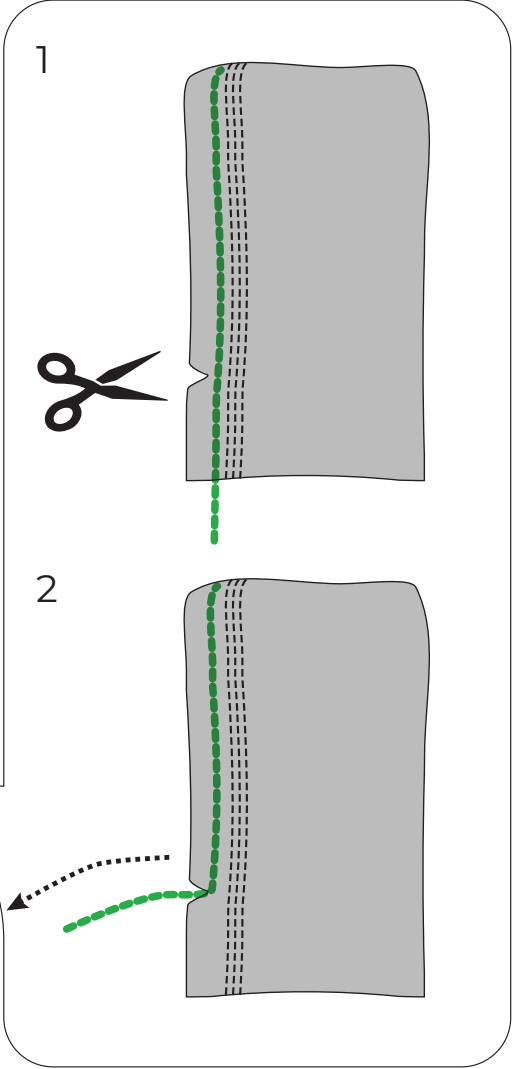
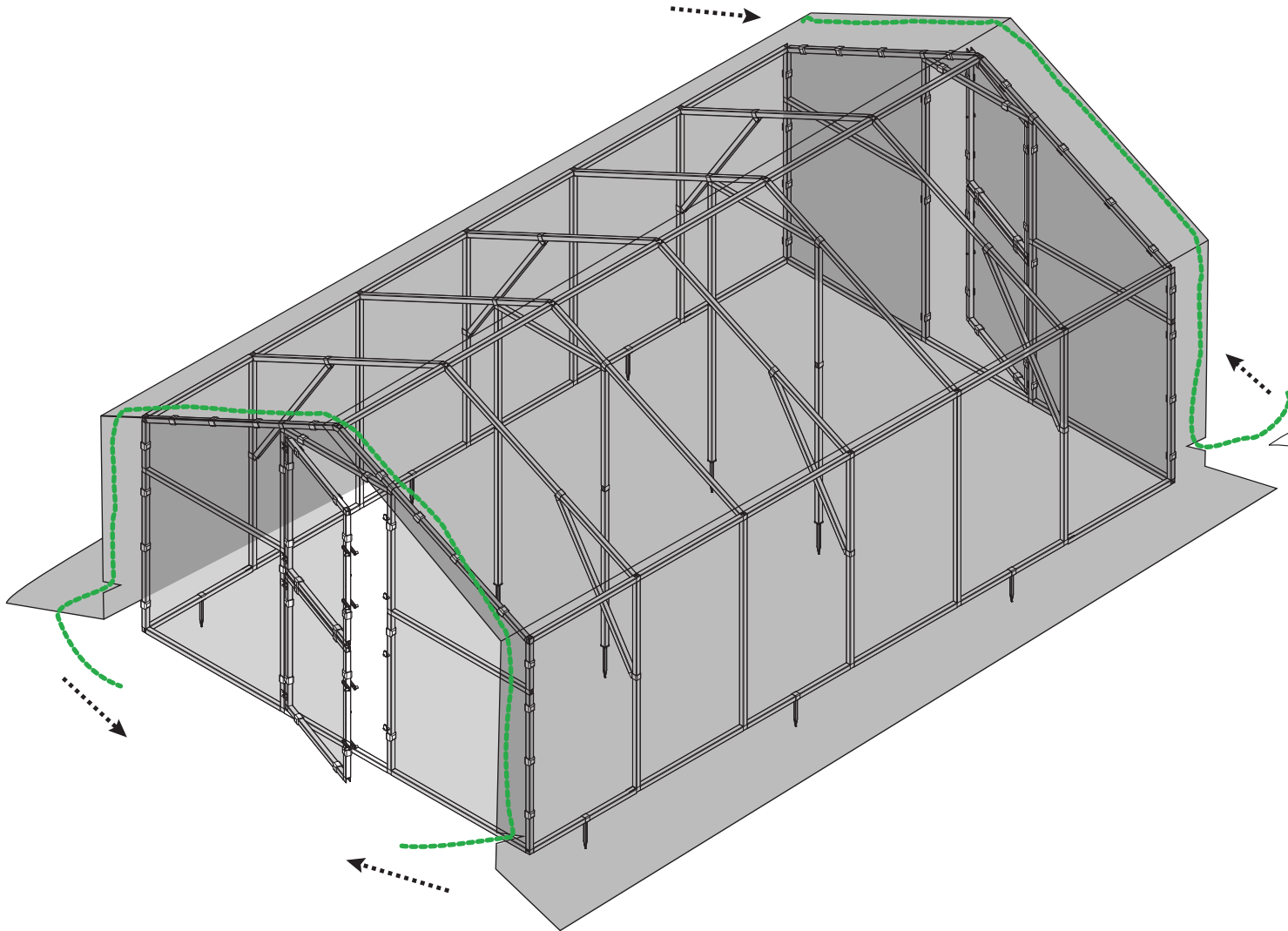

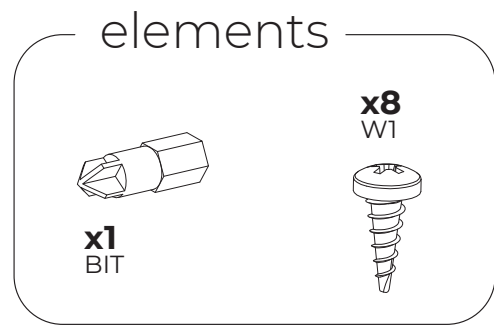
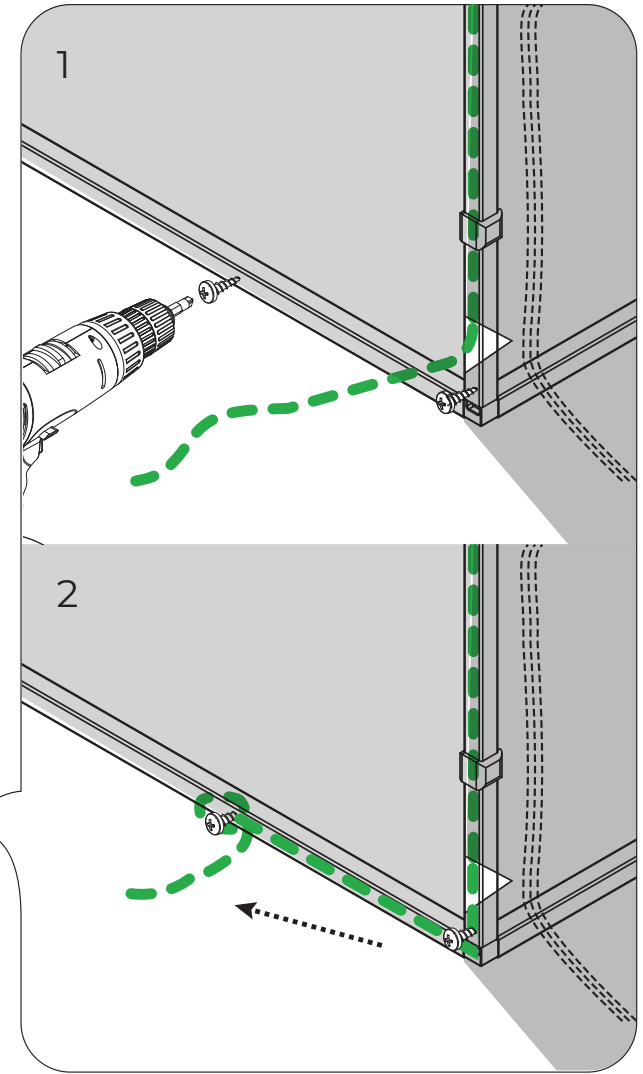
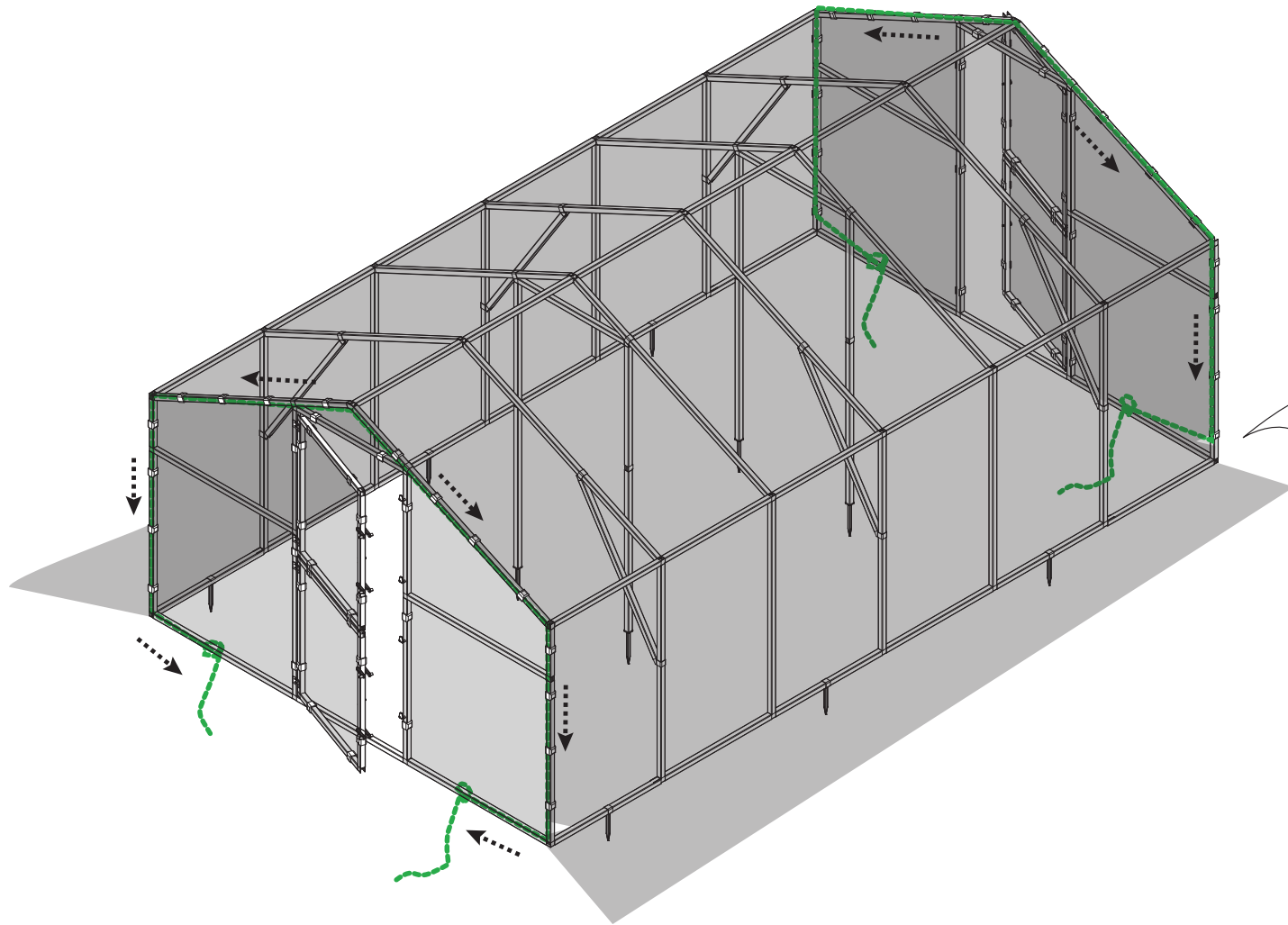



EN DO NOT CUT OUT THE FOIL EXCESS! Dig it into the ground at the depth of 40 cm. The foil should be folded in the ground.
DE DAS ÜBERMAß AN FOLIE NICHT ABSCHNEIDEN! Graben sie es bis zu einer Tiefe von 40 cm in den Boden. Die

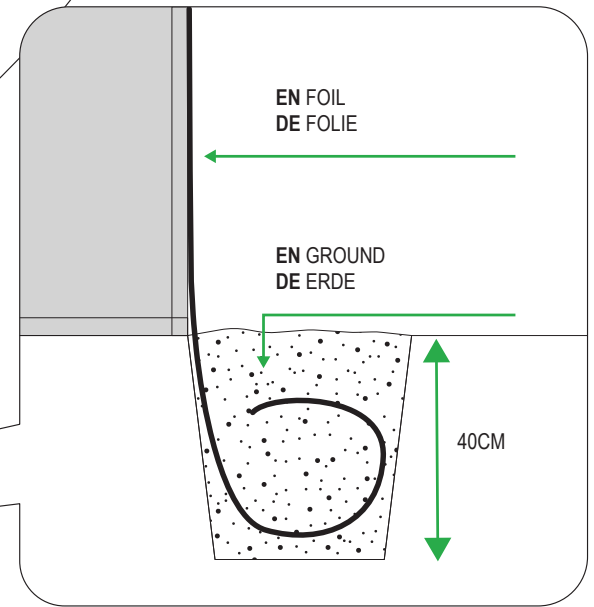
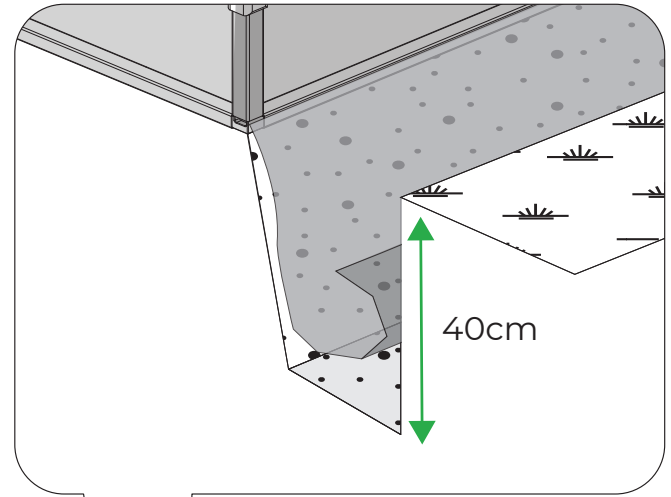
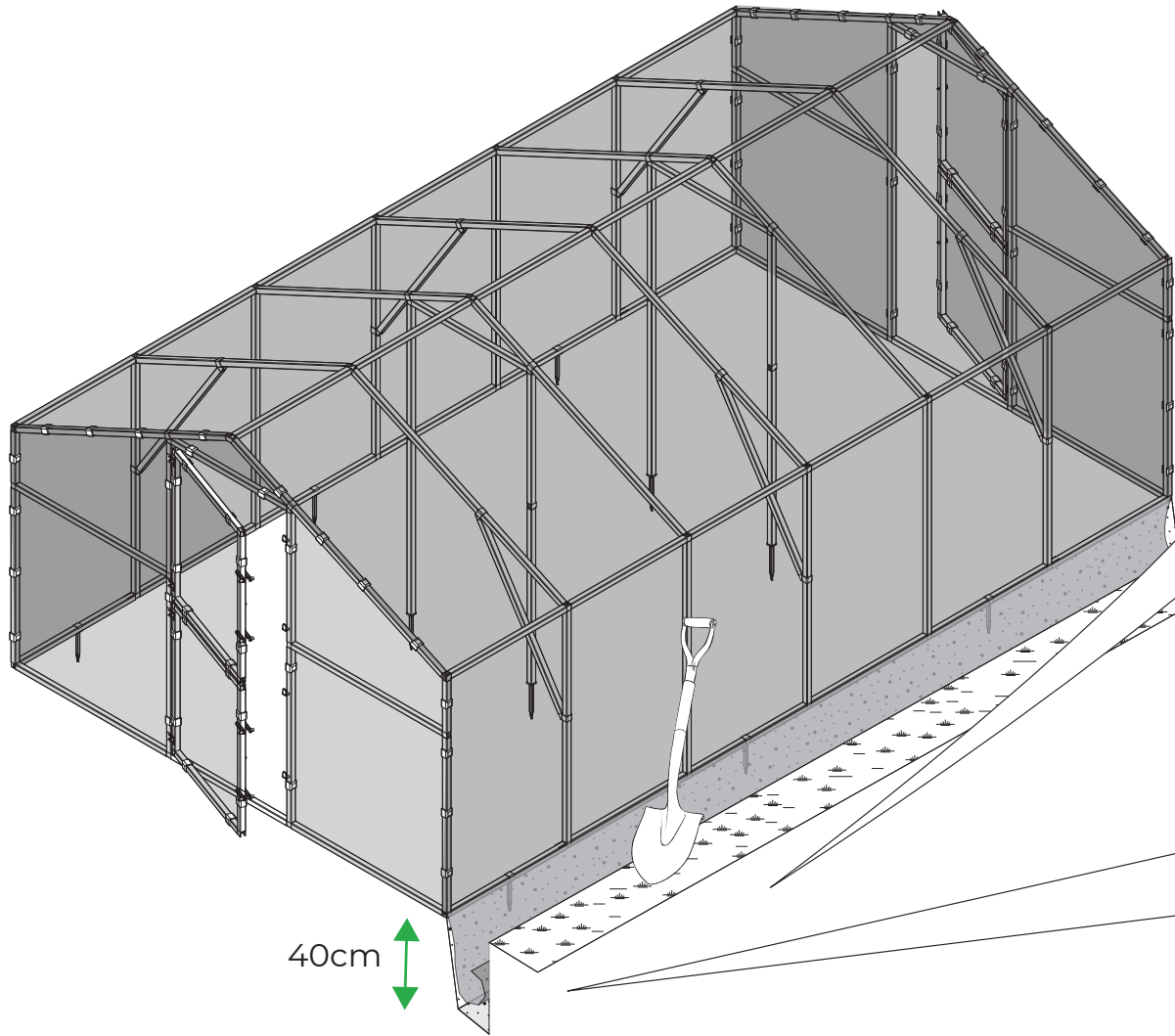

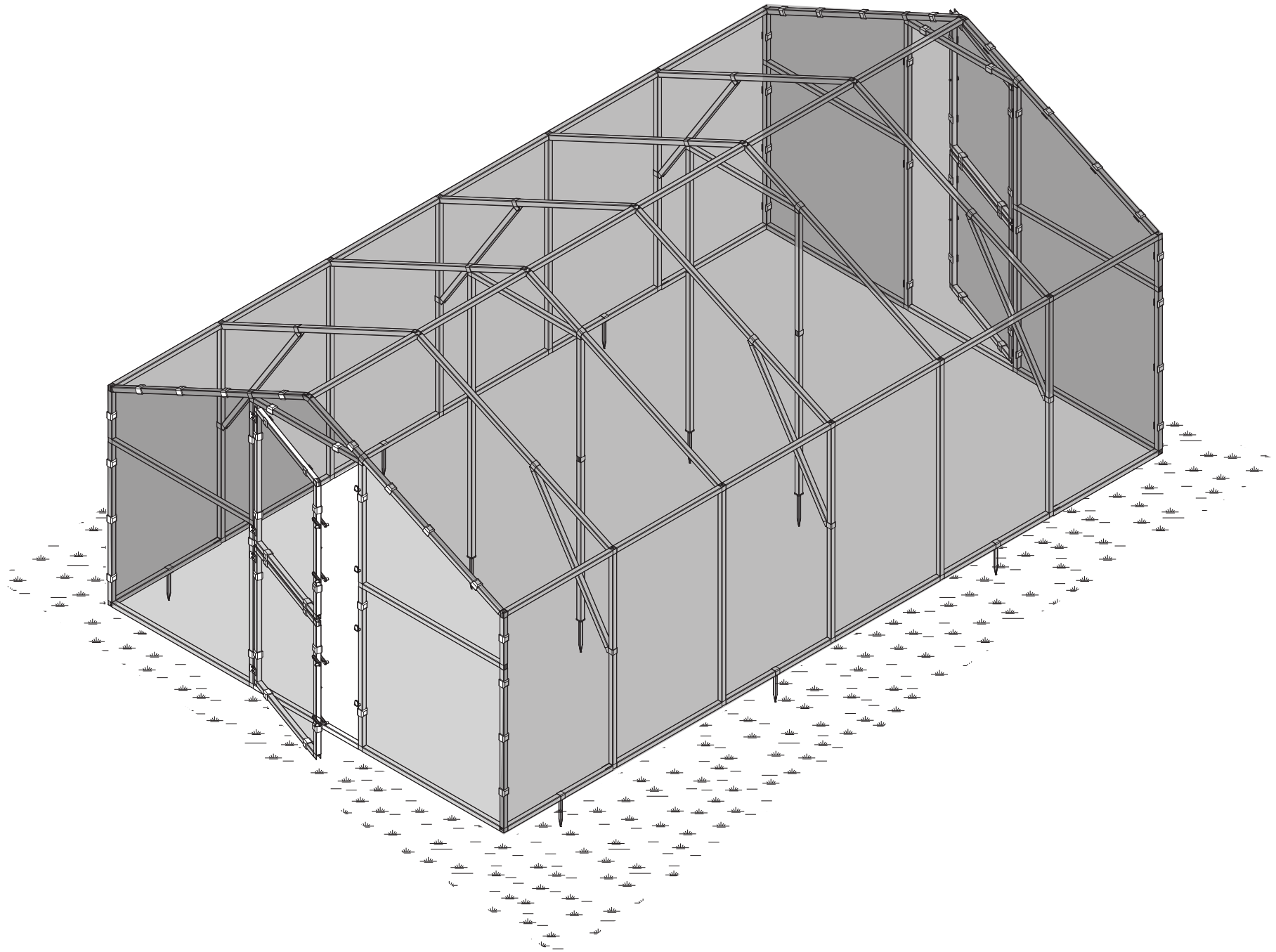



BioGreen GmbH
Marburger Straße 1b
35649 Bischoffen-Oberweidbach
Tel.: 06444 93120
Info@biogreen.de

www.biogreen.world