

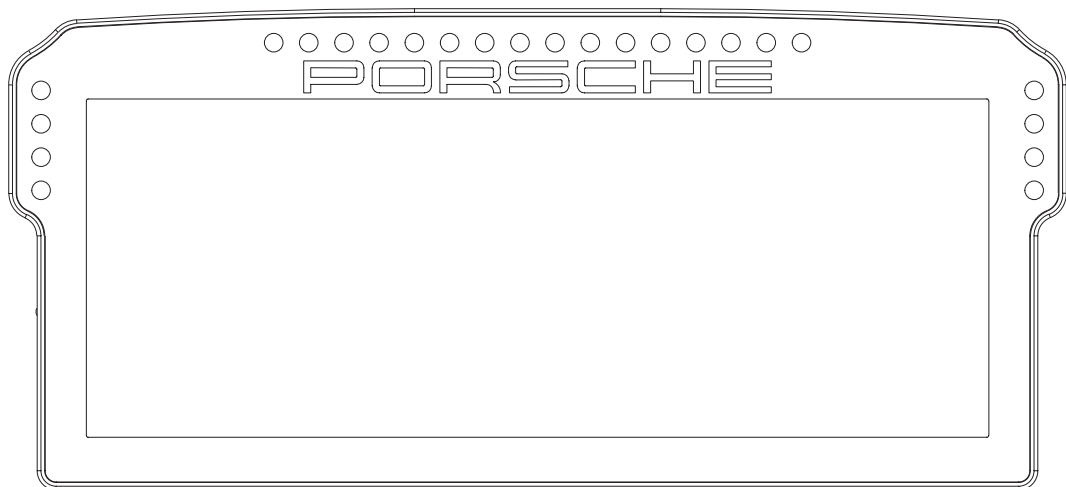

INSTRUCTION MANUAL



PORSCHE 911 GT3 CUP DASHBOARD DISPLAY UNIT

VERSION 1.4

Last updated: 19-04-2024

BEFORE YOU START:

Thank you for your purchase. In this manual we will provide you with the means to get started using your new dash!

Porsche 911 GT3 Cup Dashboard Display Unit

Features:

10.3" 1920x720 LCD

Contrast ratio 1000:1

60 FPS

24-bit Colors

24 full RGB LEDs

Multiple software options

Porsche licensed

Mounting the dash is very easy thanks to the included mounting brackets. We offer a wide range of support for most popular hardware.

In this manual we only display the two mounting brackets included with the dash. Please review our website to determine which mounting bracket fits your hardware.

Remote control

Included is a simple remote control. Batteries are not included. This is only used when the screen has gone in hibernation mode. Press the home button  to wake the display up.

Mounting the dash

To be able to mount the dash on the hardware of your choice, we provide several mounting brackets. Which ones you have received may depend on your purchase and may be different from the following ones we show. However, mounting is all more of the same. With the instructions for the two included brackets, you should be able to mount any specific ones for your hardware.

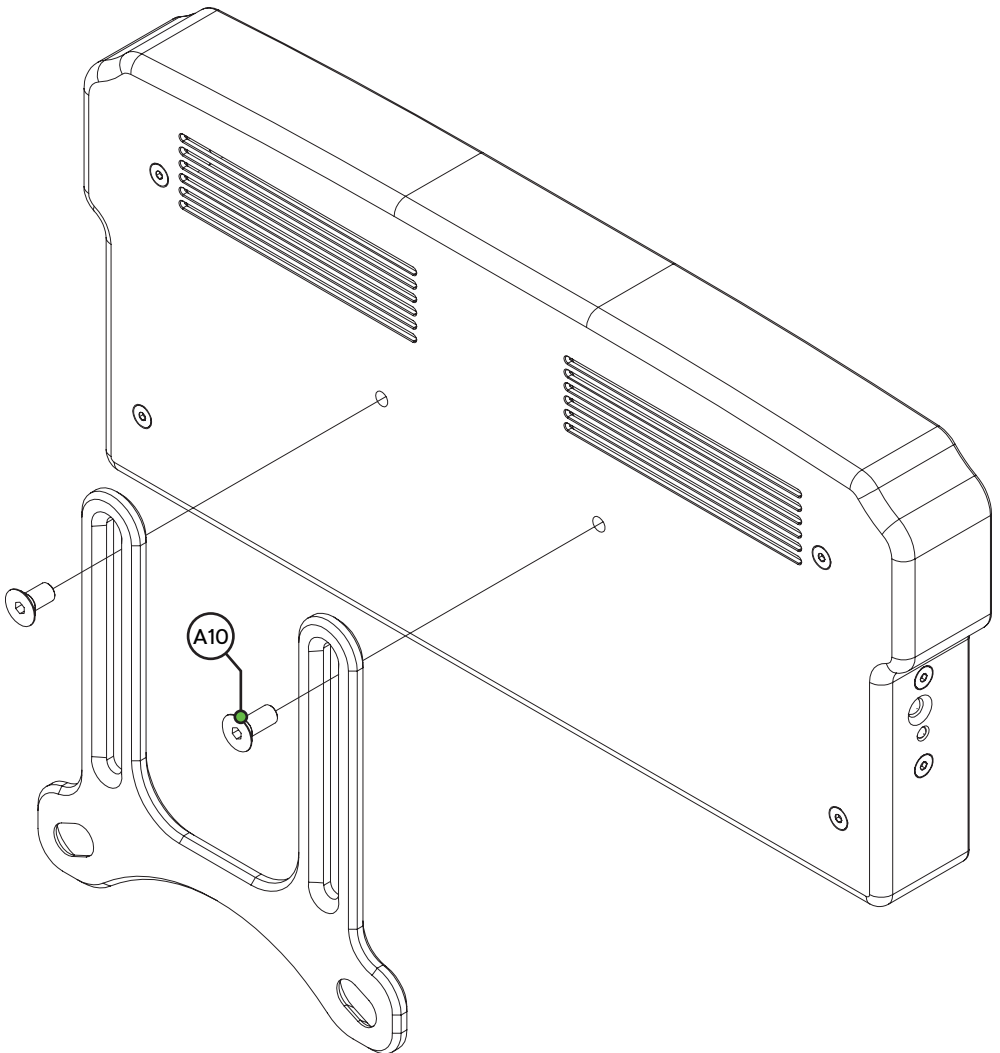

OSW/SC/VRS

Replace the existing upper bolts which hold the motor in place with the countersunk ones included (A8). Use these bolts, including existing washers and locknuts to fix the mounting bracket to the front mount.

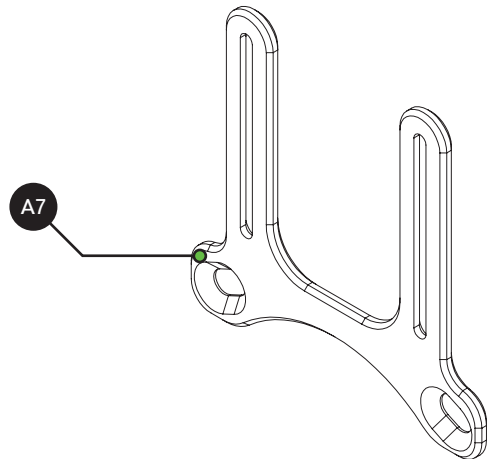
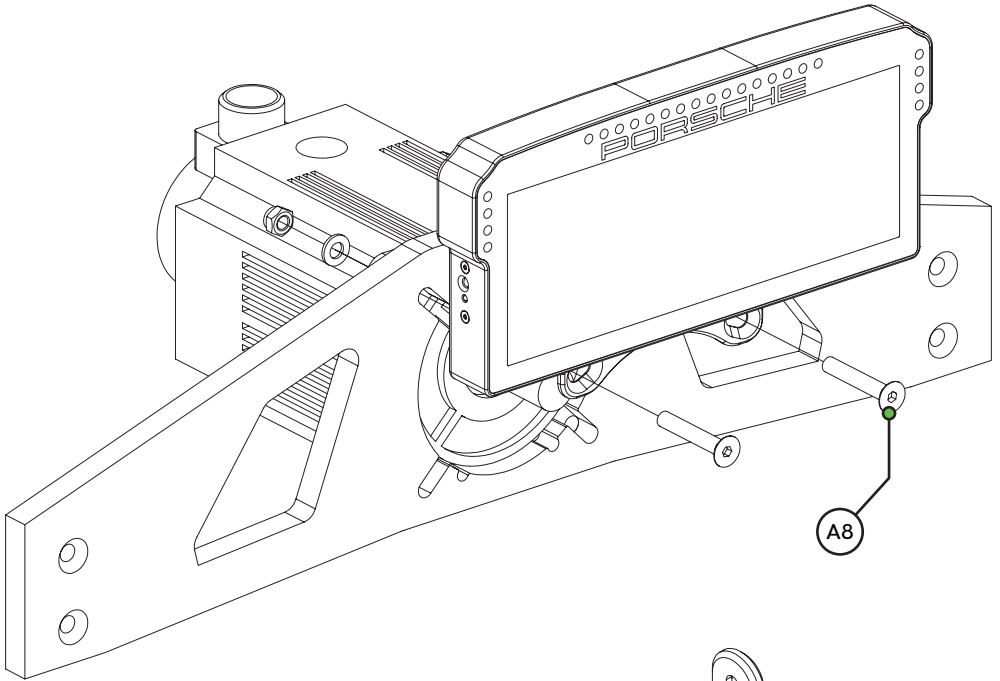

Fanatec DD1/DD2

Locate the accessory mounting holes on your Fanatec hardware and use the two bolts (A9) from our supplied hardware kit.

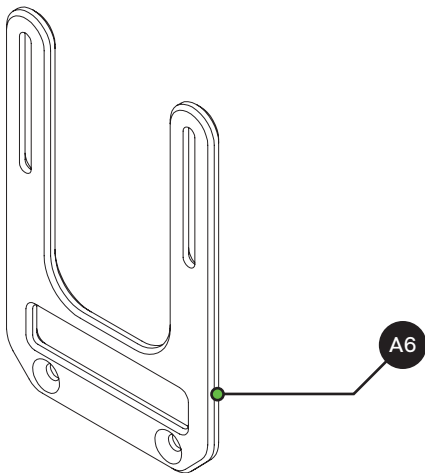
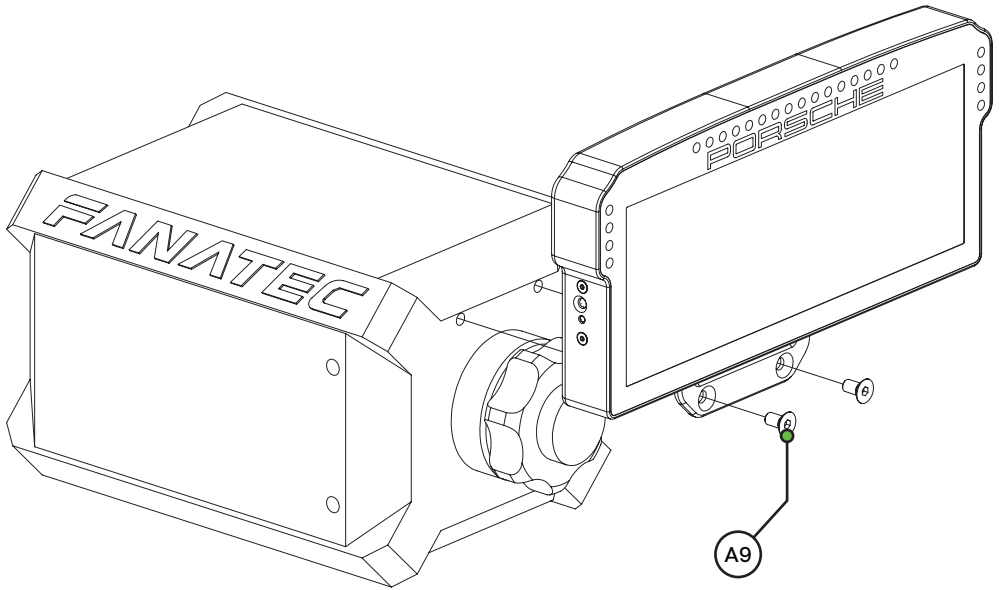

Preparation

This dash isn't just any dash, it's an actual monitor! That means running a dashboard on it almost couldn't be easier and is almost literally, plug and play.

Just be sure to 'extend' from your desktop. Press 'windows-key'+p and press 'Extend', now you can use the dash as a monitor. On to RaceDirector.

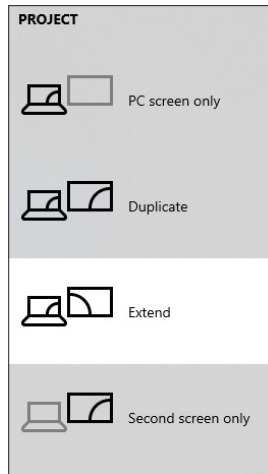

RaceDirector

Download and install the latest version of RaceDirector from www.sim-lab.eu/srd-setup

For explanation on how to install and use RaceDirector, please read the manual. This can be found here: www.sim-lab.eu/srd-manual

We will now go over the very basics to get going using RaceDirector to get you on track asap. We really urge you to go through the manual for a more in depth explanation of the possibilities RaceDirector has to offer.

First we need to activate the product, this is done on the 'Settings' (1) page.

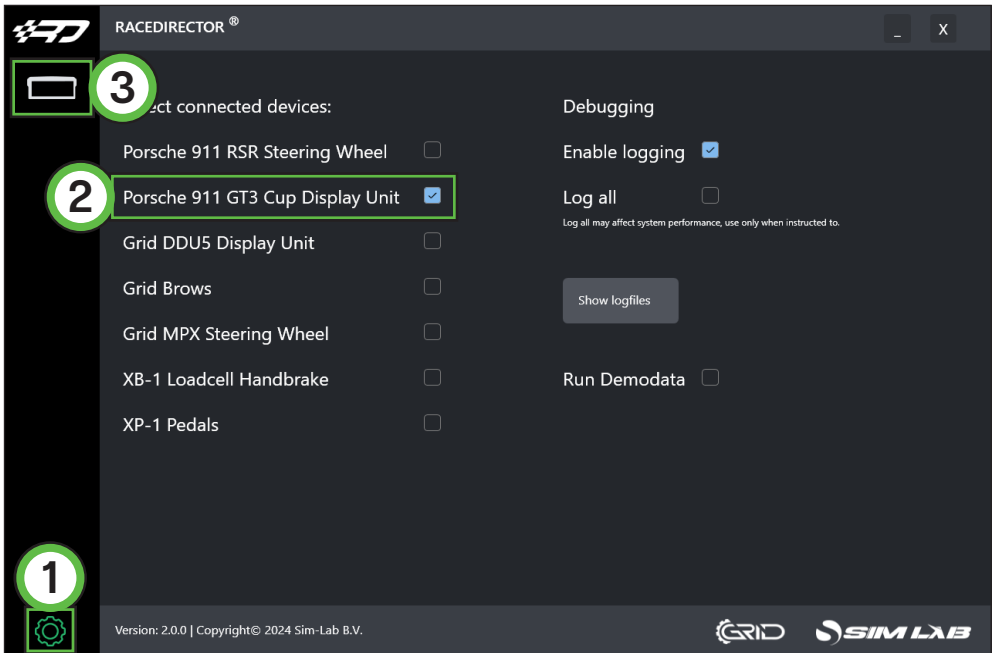

Tick the 'Activate' tickbox next to 'Porsche 911 GT3 Cup Display Unit' (2) and its icon (3) should appear on the left side of the screen. Selecting the icon (3) will take us to its device pages.

Device pages

DISPLAY (A)

Almost all of the options found here speak for themselves, though for the sake of being complete, we will go over them on by one.

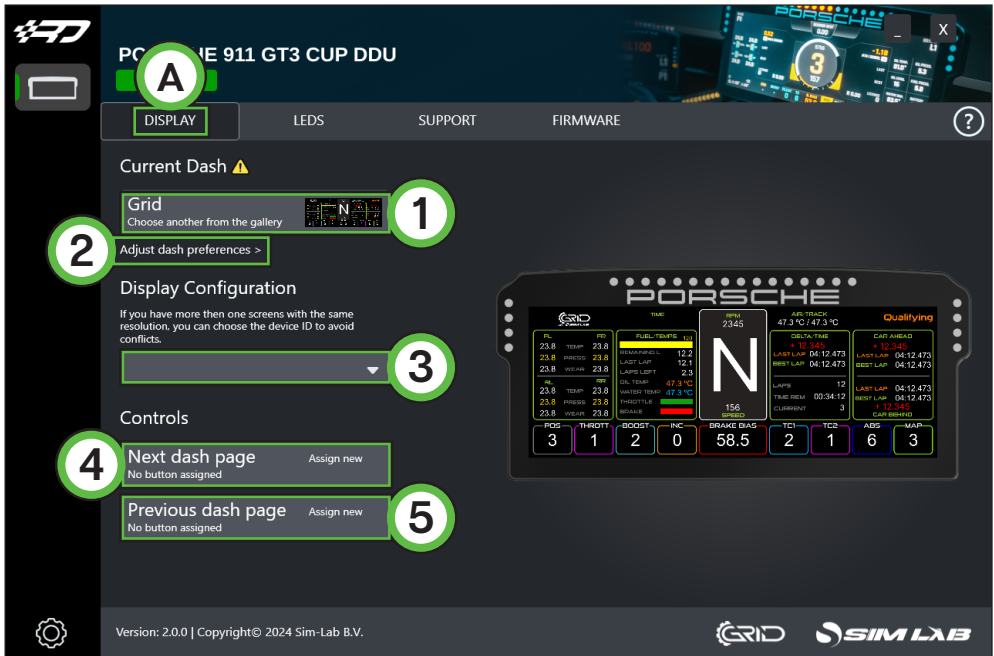

- 'Current Dash' (1)

This allows you to select a dash for a given car. We do not support all cars in every sim. In case a caution symbol ⚠ is shown, the selected dash requires installation of a font. Click the icon and a window with instructions will pop up. Follow these to manually install the fonts required. After restarting RaceDirector, you are good to go.

- 'Adjust dash preferences >' (2)

A new window will allow you to adjust some dash preferences. (See next page)

- 'Display configuration' (3)

This will make sure the chosen dash is rendered on the intended display.

- 'Next dash page' (4)
Cycle to the next page of the loaded dash. Select the appropriate button you want to use and press 'Confirm'.
- 'Previous dash page' (5)
Cycle to the previous page of the loaded dash, works like described above.

Note: when the page controls are configured, they won't affect a dash *unless* a sim is running *or* the 'Run Demodata' option is ticked in the RaceDirector settings.

Dash Preferences

These are common settings shared among dashes.

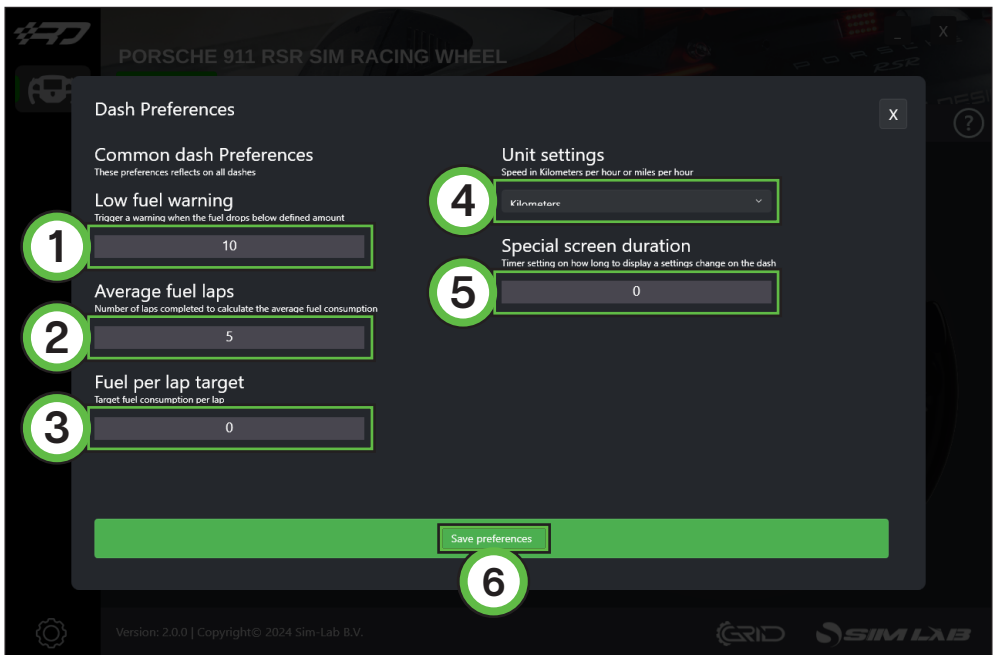

We do expect these to slowly expand, depending on requests from the community and new cars added to our favorite sims.

- 'Low fuel warning' (1)
This number (in liters) will be used for the dash to know when to activate the 'Low Fuel' alarm or warning.
- 'Average fuel laps' (2)
This value determines how many laps are used to calculate average fuel usage. The average is reset every time you enter the pits to keep the average a fair number.
- 'Fuel per lap target' (3)
This value (in liters) allows you to set a target fuel consumption (per lap), great to use in endurance racing.
- 'Unit settings' (4)
At the moment this setting only applies to the speed variable.
- 'Special screen duration' (5)
Special screens are overlays which are triggered when adjusting certain functions. Think brake balance, traction control etc. This number (in seconds), changes the duration of the overlay. A value of 0 is turning the feature off entirely.

When happy with your settings, press 'Save preferences' (6) to return to the main RaceDirector window.

LEDS (B)

This will be explained in two parts, first we will go over the main options.



- 'Default' (1)

This selection menu is how you select an existing profile and load it, or create a brand new one. In this case, the 'default' LED profile is loaded. You can create and store as many as you like.

- 'Save changes to profile' (2)

Use this button to save changes made to a profile, or use it to save a new profile. This button also warns you have when a change was made to an existing profile, turning orange as a warning.

- 'LED Brightness' (3)

This slider changes the brightness for all LEDs on the device.

- 'RPM redline flash %' (4)

This is the value in % where your redline flash or shift warning will be listening to. This does require your revlights to have the 'RPM redline flash' behavior enabled. This is a global setting per device.

- 'Blinking speed ms' (5)

This determines how slow or fast your LEDs will be blinking in milliseconds. This is a global setting per device and requires the 'Blinking' or 'RPM redline flash' behavior to be activated. Warning: please take care with low settings when you are sensitive to seizures. We recommend to start too slow (high ms) and tweak from there.

- 'Test all LEDs >' (6)

This opens up a pop-up window where you use test input to see what the LEDs do using the currently loaded profile.

One thing which is quickly apparent from switching to this page, is the addition of colored LEDs. The loaded LED profile is visually represented on the device, which can be adjusted very easily. Every LED can be clicked on and adjusted inside the LED setup window.

Clicking on any LED/color brings up the LED setup window. This shows the LED number (1) and the functions which can be configured. Each LED can behave differently and can contain up to 3 functions (rows) at a time. An overview; 'Condition' (3), 'Condition 2' (4), 'Behaviour' (5) and 'Color' (6). There is also the possibility to 'Copy settings from another LED' (8). There is also a 'Sorting' (2) and a 'Remove' (7) function.

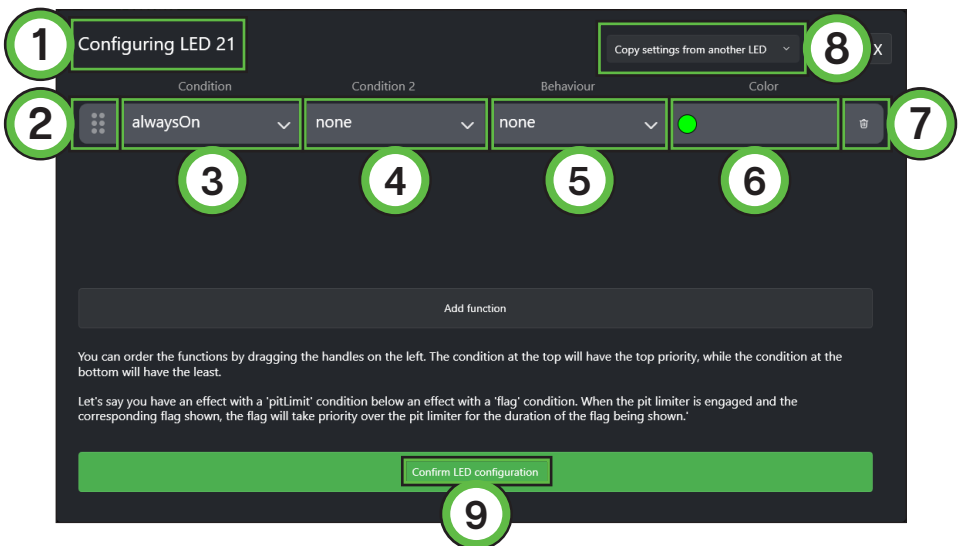

When happy with your settings, there is the obligatory 'Confirm LED configuration' (9) button. This confirms your LED settings and returns you to the main RaceDirector window.

There should be enough info in the provided default LED profiles to be able to adjust LED settings to your liking. To start building your own profile, we suggest to copy an existing one and change where needed. The advantage is you always have a backup of the default profile to fall back to.

We do recommend to read the [RaceDirector manual](#) for detailed information on functions, settings and basic rules for the LED settings and the LED setup window.

SUPPORT (C)

If you run into trouble with your hardware, here are a few options to help you in finding a solution.

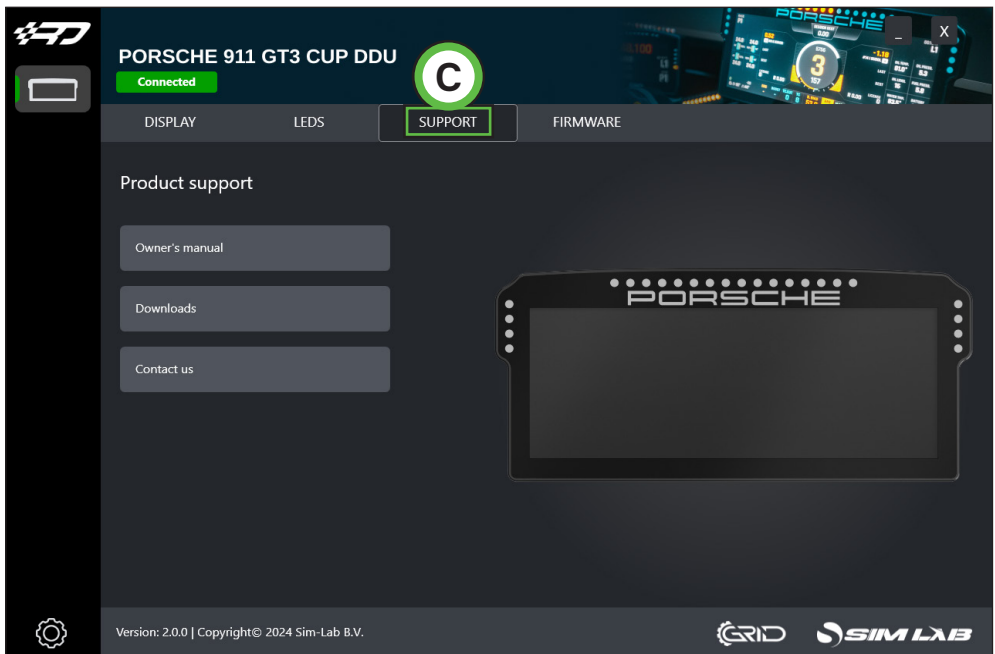

FIRMWARE (D)

On this page you can see the current firmware loaded on the device. If your firmware is out of date, we recommend to update it using our tool.

PORSCHE 911 GT3 CUP DDU

Connected

DISPLAY LEDES SUPPORT **FIRMWARE**

Your device is up to date
Current firmware version: 1.01

Available firmware version: 1.01

Keeping your device up to date is always recommended for the best experience.

How to update
Press the button below to download our device updater. This simple program allows you in a simple way to update all of our devices.

1 Firmware update tool

Version: 2.0.0 | Copyright© 2024 Sim-Lab B.V.

GRID SIM LAB

RaceDirector keeps tabs on current firmware versions. When it detects a difference, a notification ● will let you know more recent firmware has been detected.

Press 'Firmware update tool' (1) to download the tool.

For more information on how to use the tool, please see its documentation: sim-lab.eu/firmware-updater-manual

Simhub Support

For advanced users, we do still support people who prefer using Simhub. When adding a device, choose the 'GRID DDU10'.

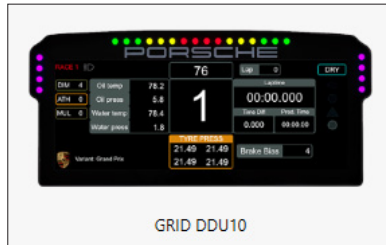

Changing the LEDs' functions.

To change the LED effects you need to know their numbering to identify them on the device. The following schematic shows the LED numbering for reference.

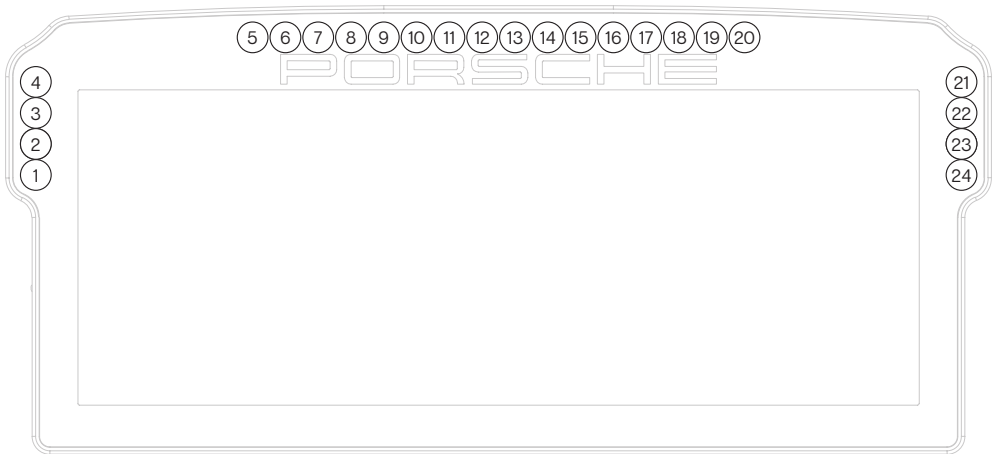

There should be enough info in the provided default LED profiles to be able to adjust LED settings to your liking. To start building your own profile, we suggest to copy an existing one and change where needed. The advantage is you always have a backup of the default profile to fall back to.

Note: for issues/troubleshooting your Simhub profiles, please refer to Simhub documentation or Simhub support.

Inputs and indicators

Since this dash is a bit more involved than our usual products, we will show the layouts for the input and indicator sections of the dash.

Bottom - Inputs

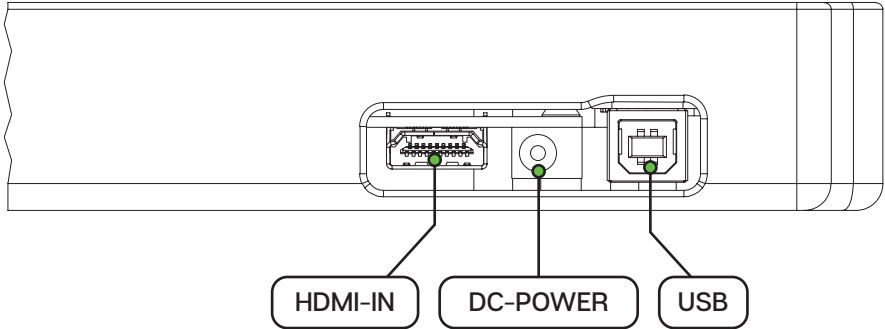

Side - Indicator LEDs

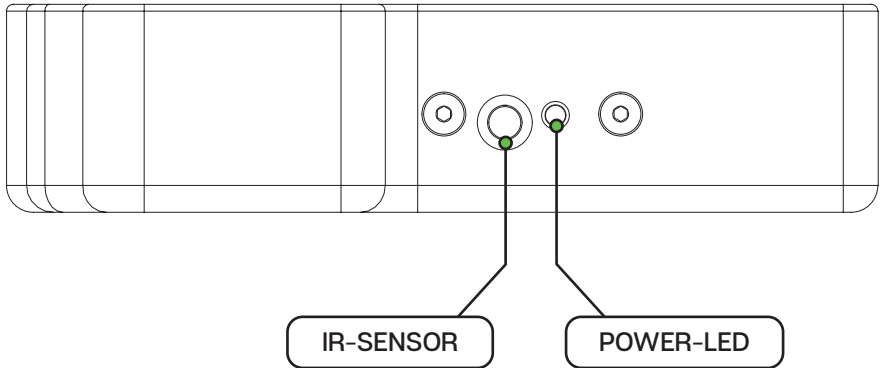

Bill of materials

IN THE BOX			
#	Part	QTY	Note
A1	Porsche 911 GT3 Cup DDU	1	
A2	USB B cable	1	
A3	HDMI cable	1	
A4	Remote control	1	
A5	DC power supply	1	
A6	Bracket Fanatec DD1/DD2	1	
A7	Bracket OSW/SC/VRS	1	
A8	Bolt M8 X 50 DIN 7991	2	
A9	Bolt M6 X 12 DIN 7991	2	Used with Fanatec.
A10	Bolt M5 X 10 DIN 7991	2	To fit mounting bracket to dash.

More information

If you still have some questions regarding assembly of this product or about the manual itself, please refer to our support department. They can be reached at:

support@grid-engineering.com

Alternatively, we now have Discord servers where you can hang out or ask for help.

www.grid-engineering.com/discord

[Product page on the
GRID Engineering website:](#)

