

Electric scooter instruction manual

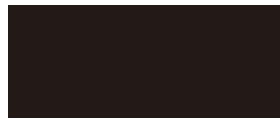
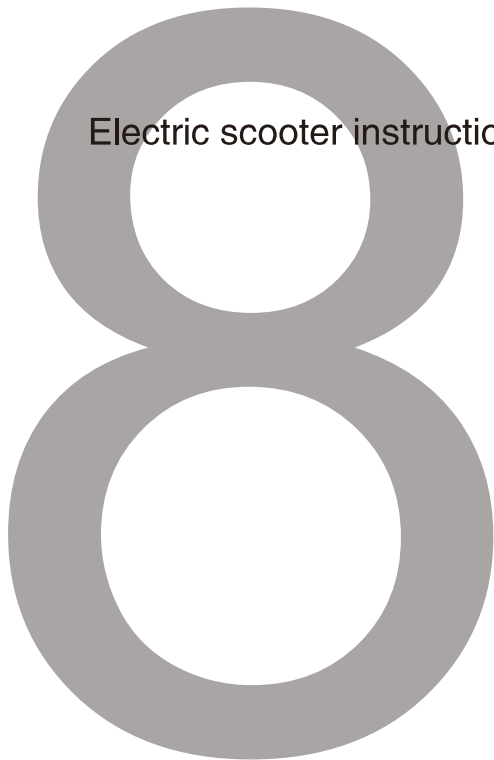

**C
O
N
T
E
N
T
S**

1 Getting started guide	1
2 Functional specifications	5
3 The battery and motor instruction	6
4 Learning to drive	8
5 Folding and handling	9
6 Daily protection and maintenance	10
7 After-sales service	13
8 Guarantee card	14

Unfold

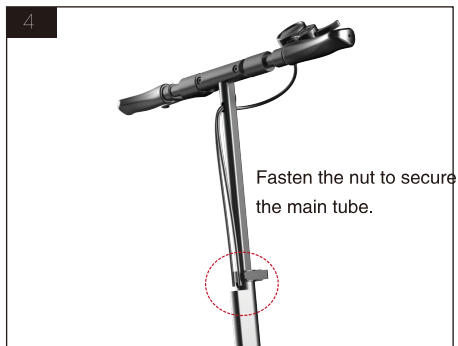
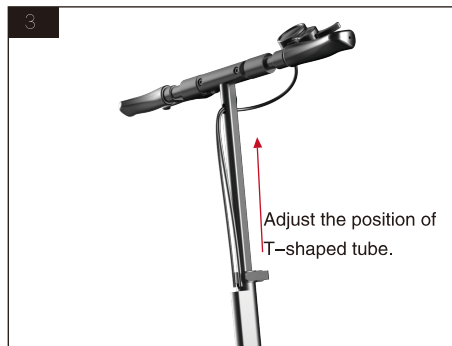
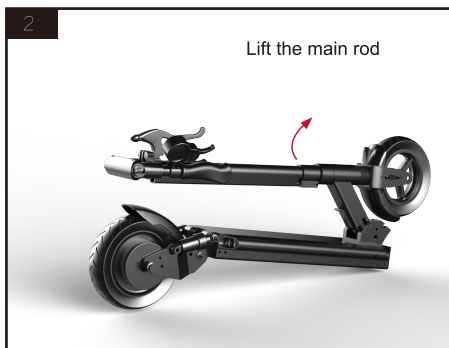
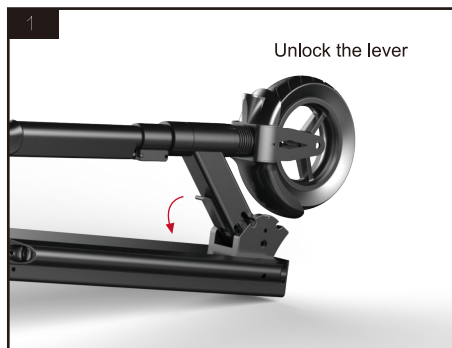

Fold



Step 1: power on

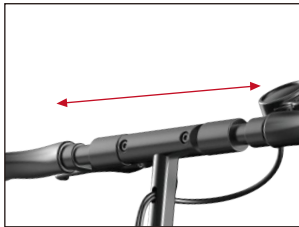

Step 2: extend the T-shaped sleeve outward

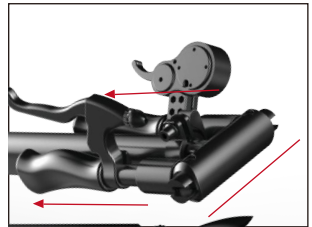

Step 3: bend the handle downward



Step 4: unscrew the nut.



Step 5: adjust T-shaped tube downward



Step 6: push forward and at the same time hold down the lever when folding the head.

Basic operation:

Power Switch

Press power switch for over 3 seconds ,then the LED screen will turn on. The device will turn off automatically if it doesn' t move after 90 seconds.

Speed Control

After power on, press power key, L1 shows on the screen, indicating grade 1 (15–20km/h).Press power key again, then L3 shows on the screen indicating grade 3 (40–60km/h). The speed controller maintains the speed between 1km/h and 65km/h.Press power key for 2 or 3 seconds at the start window of the instrument, then the front light turns on.

Power Indication

Number of bars indicates the rest power of lithium battery.

Note: Recharge when there is only one bar, as over discharging may damage the battery.

Mileage

After power power on, ODO will be displayed on the LED screen.

Press power key,TRIP will be displayed; press power key again, voltage will be displayed.

When TRIP is displayed, holding down MODE key for three seconds can reset TRIP data.



Speed Control

With this handle, the user can control the speed according to actual situation.

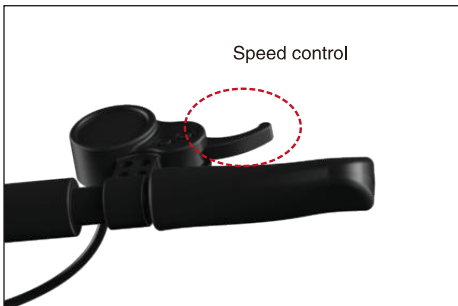

LED Screen

After power on, the LED screen displays ODO.

Press the power key, it displays TRIP.

Press the power key again, it displays voltage.

When displaying TRIP, press MODE key for 3 seconds to zeroing TRIP data.

Handle



Battery Overview

The capacity of the battery, to a great extent, decides the endurance mileage of the vehicle. Battery with larger capacity can enable longer endurance mileage. This compact battery (48V 21AH) contains power energy of 1008wh, thus to enable further traveling.

Note: Before the first use of the electric scooter, it's a must to fully charge it.

Features of the battery of scooter

Features of the electric scooter:

1. Balanced charging protection: automatically balance the voltage of internal cells to protect the battery.
2. Overcharging protection: overcharging may severely damage the battery. When the battery is fully charged, the charging process will be ceased automatically.
3. Charging temperature protection: the battery maybe damaged, or works improperly if charging in the environment which temperature is under 5°C or above 40°C.
4. Overcurrent protection: overcurrent during charging process may severely damage the battery. When the charging current is larger than 8V, the battery will stop charging process.
5. Overdischarging protection: overdischarging may severely damage the battery. When the voltage drops to 44V, the battery will stop output.
6. Short-circuit protection: if there is short-circuit, the battery will stop output to protect itself.
7. Auto sleep: after initiation, the battery will enter sleep mode if there is no load in 20 minutes to save power.

Charging

1. Connect the charger with AC mains.
2. Connect the power-off electric scooter with the charger.
3. The ideal charging temperature is 5 –40°C. If the cell temperature is not in the range, the battery management system will cease charging process.

The battery and Instructions for motor use

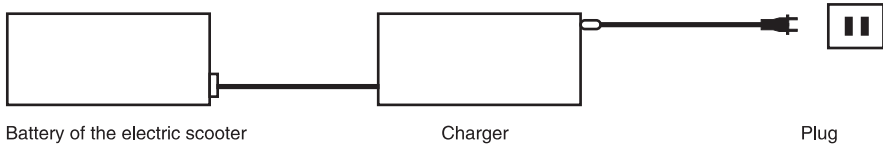

Battery capacity

36V	10.4AH
	18.2AH
48V	10.4AH
	13.0AH
52V	13.0AH

Leaning to drive

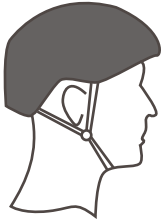

You may fall down and get hurt during learning. Please wear helmet and protective equipment as the picture shows all the time during the learning.

Attentions:

1. Necessary protective equipments such as helmet,gloves,elbow guard and waist support;
2. It's forbidden to ride on ragged and wet floors, such as unpaved road, rocky road and roads with ice and ponding;
- 3.It's forbidden to ride on the road which slopes is larger than 15° ;
- 4.It's forbidden to be used by people under 15 or above 60 years old;
- 5.It's forbidden to be used by people under the effect of drag or alcohol, or people with limited action and reaction ability;
- 6.It's not suggested to ride in cold winter days;
- 7.It's forbidden to ride in rainy days;
- 8.Please slow down on slopes;
- 9.Situations which are not suitable for riding, caused by the rider or other objective causes;
- 10.For charging, it's a must to connect the cord with charging socket of the electric scooter first before connecting with the mains;

You have to practice a lot to acquire the skills of safe driving. Unskilled driving or failed to following this manual when using the product may cause personal injury or property damage of the driver or others. We are only liable for the fault or damage of the product, and will not take the responsibility of personal injury or property damage caused by the use of this product.

Folding and handling

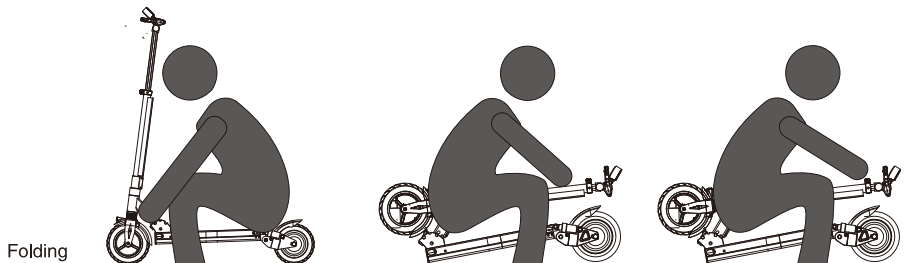

Make sure the electric scooter is powered off, hold the tube and push aside the thumb shifter, then open the folding lever.

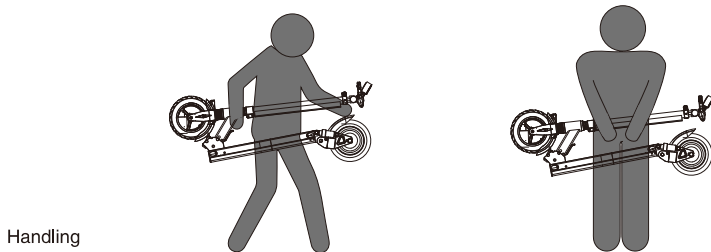

Handling the scooter by holding the tube with one hand or two hands.

Daily protection and maintenance

Clean and storage of electric scooter

If there is stain on the surface of the scooter, just use soft cloth with clean water to scrub. If there is stubborn stain, please apply with toothpaste and scrub with toothbrush, and then clean with wet cloth. If there is scratch on the plastic part, use abrasive paper or other abrasive material to polish.

Note: Do not use alcohol, gasoline, kerosene or other corrosive chemical solution to clean, otherwise the appearance or internal structure of the scooter may be damaged. It's forbidden to flush with hydraulic cannon. Make sure the electric scooter is powered off and disconnected with power cord and the cover of charging port is closed when cleaning; otherwise electric shock or serious fault may occur due to penetration of water.

When disused, it's suggested to store the electric scooter at dry and cool place in house. Outdoor storing for a long time should be avoided. Outdoor environment with blazing sun, too hot or cold weather will speed up the aging process of over all appearance and tyres, and shorten the service life time of the electric scooter and its battery set.

Maintenance of battery of the electric scooter

1. Please do not use battery set of other model or brand, otherwise there will have safety risk.
2. It's forbidden to touch, dismantle or puncture the battery. Please avoid touching the battery contact with metal, otherwise the battery may be damaged, and people may get hurt or die.
3. Only original charger for charging, otherwise there is a risk of damage or fire.
4. Improper disposal of the used battery may seriously pollute the environment. Please do not litter the battery set. Dispose the battery set according to local laws and regulations, thus to protect natural environment.
5. After each use, please fully charge the battery before storage, thus to prolong the service lifetime of battery.

Do not put the battery in the environment with temperature higher than 50°C or lower than -20°C (for example, Do not put the electric scooter or its battery set in car under blazing sun in summer). It's forbidden to put the battery set into fire, otherwise the battery set will be damaged, overheated, or even on fire. If the battery will be disused for over 30 days, please fully charge it first and store it at cool and dry place. The disused battery should be fully charged every 60 days, otherwise the battery may be damaged and such damage is not covered in warranty.

Daily protection and maintenance

Pls avoid recharge when the power is used up, and recharge power timely, it can increase the battery service life. Under normal temperature using, the battery can work for high range and feature. Under below 0°C temperature, the battery will reduce range and feature. For example, under -20°C temperature, the range only is half of normal temperature even less than half. And when the temperature increasing, the battery range will resume normal value.

Reminding: Fully charged electronic scooter, the power will exhaust after about 120–180 days. There is a smart IC inside the battery with record of charge and discharge power. When no charge for a long time, the battery can not be charged again. If do not recharge battery, it will damage the battery because of over discharge, and this damage can not recover, and can not enjoy free warranty. (Warning: disassembling battery is prohibited by non-professional, otherwise will cause safety accident because of short circuit.

Disc Brake Adjustment

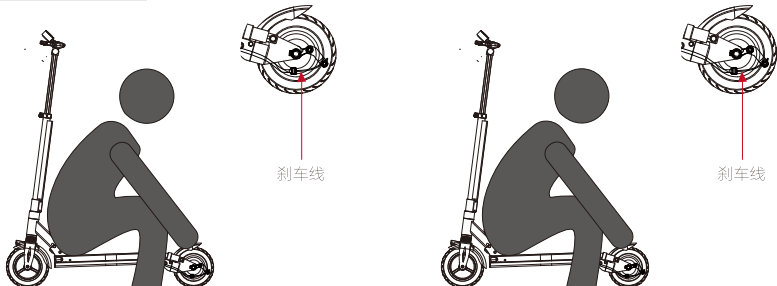

If the brake is too tight, pls use M5 hex wrench to loose the screw of the disc brake holder by anticlockwise direction, and short the brake cable, then fix the screw tightly; if the brake is too loose, just loose the screw and make the brake cable to be longer and then fix the screw tightly.

Adjusting shaking handles

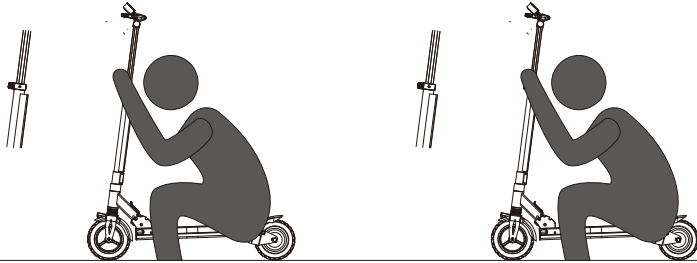

If the main rod of the electric scooter shakes during running, please use a M10 hexagon wrench to tighten the bolts at the folding mechanism.

Use of inflation inlet

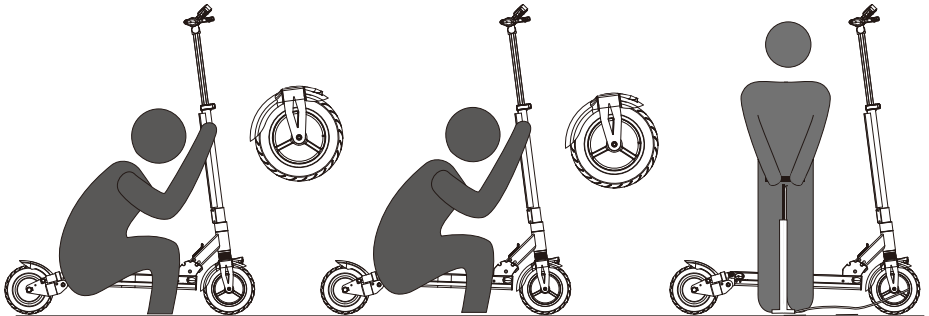

If the main rod shakes during the running, please tighten the nuts for clamp and secure it.

After-sales service

For any problem listed in following table,our distributor will provide perfect after-sales service within the scope of warranty.

Part	Quality issue	Warranty period	Remarks
Motor	Seriously broken rubber wheel hub,faultry motor	12 months	Free repair
Accelerator	Unable to use with normal conditions (except damage caused by impact)	3 months	Free repair
Controllor	Fault during normal use	12 months	Free repair
Charger	Fault during normal use	3 months	Free repair
Lithium battery	No output during normal use	12 months	Free repair
Framework	Deformation or fracture during normal use	6 months	Free repair

Attentions for warranty

Faults caused by any of following causes are not within the scope of warranty:

1. Failed to maintain according to this user manual;
2. Damage caused by misuse, traffic accident or accidental collision;
3. Damage caused by riding on abnormal roads or accidental collision;
4. Please do not expose this product under blazing sun or outdoor for along time,as that will speed up the aging process of the product and cause malfunction.
5. Quick aging and malfunction of the product caused by dangerous play with the electric scooter, such as acrobatic play;
6. Damage of the vehicle caused by natural disaster or irresistible force;

Note: Pleas erefer to the our website for updated information about after-sales,replacement,payable and free warranty.

Start date of warranty extension	(DDMMYY)
Start date of warranty extension	(DDMMYY)
Start date of warranty extension	(DDMMYY)

User information:

Name: _____

Contact number: _____

Email: _____

Address: _____

Product information:

Model: _____

Repair station: _____

Date of return: _____

Fault description: _____

Fault cause: _____

Signature of the repairer: _____

