



Permanent-electro magnetic systems

EN

TECNOLIFT line - Magnetic lifting systems



MaxX[®]

Hand controlled magnetic lifters

MaxX[®]

Safe and handy lifting



MaxX magnetic lifters are the ideal solution for handling easily and safely any steel workpiece whether rough or finished.

Their compact size and low weight maximize the crane capacity through a range of models with lifting capacities (WLL) from 125 kg to 2000 kg and specific versions for round surfaces and thin thicknesses

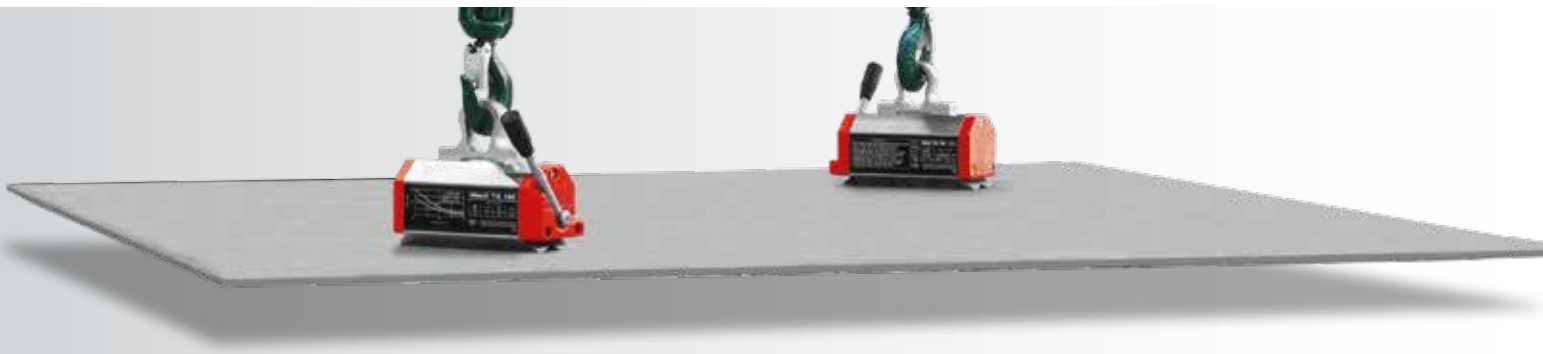

MaxX lifter for every need in manufacturing

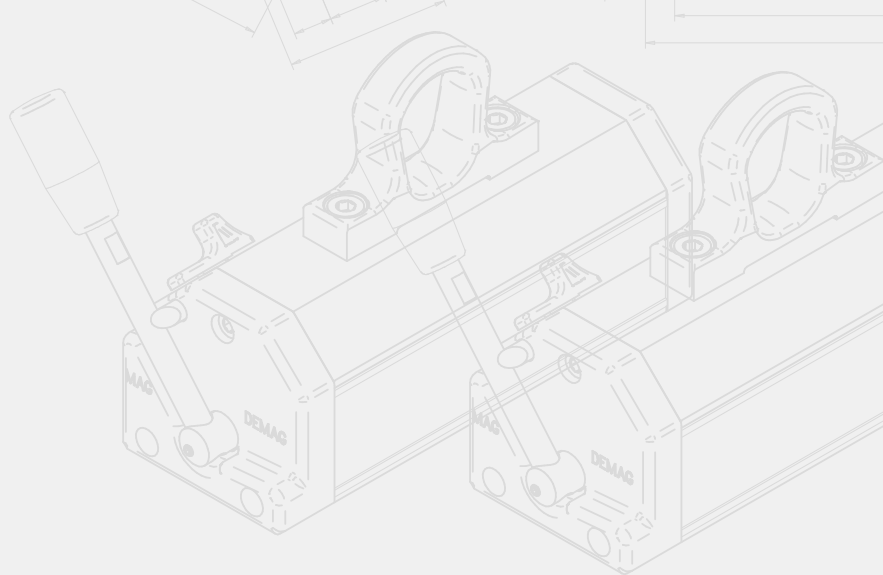

The polar geometry is designed to fit perfectly loads of all kinds with both flat and round surfaces while minimizing operating air gaps.

The **TG** series maximizes the magnetic performance for lifting thin sheet metal and pipes



MaxX[®]

A design of excellence and a perfect constructive realization

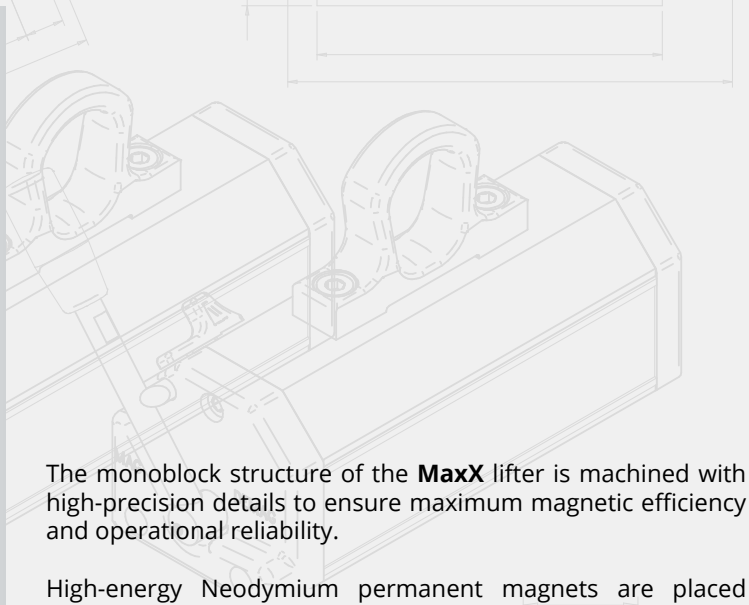

The monoblock structure of the **MaxX** lifter is machined with high-precision details to ensure maximum magnetic efficiency and operational reliability.

High-energy Neodymium permanent magnets are placed inside dedicated slots of the stator and inside the rotor core in order to be protected in case of shocks during the work.

The magnetic rotor rotates inside the magnetic stator always maintaining the same distance over time thanks to the precision machining, the use of bearings and a unique manufacturing process that involves the magnetization of the lifter once assembled.

The final nickel-coating treatment protects the product against oxidation and the wear and tear of time.

See 3D video



The details make the difference

The **ball bearings** located at the ends of the MaxX are an integral part of the monoblock and ensure smooth rotation of the activation lever and reliability over time .

The **handle** - secure and ergonomic - is easy to grip even with working gloves to perform magnetization and demagnetization cycles.

The **hooking detail** is designed for the firm and secure coupling with the lifting hook.

The **safety catch** of the lever - simple but effective - ensures optimal operation even after years of work. Its position clearly shows the operator when the lever is placed in safety mode once the hoist is activated.

The **performance plates** located on both sides are laser engraved on aluminum supports for durability. They clearly indicate performance on flat, round surfaces under operating conditions as a function of the quality of the contact (air gap). Each lifter displays its own serial number, the month and year of manufacture.

The **polar "V" geometry** to suit flat and round surfaces.

The **Quality Control and testing** are performed on all lifters MaxX during the various stages of production at our plant in Lainate Italy to guarantee the correct performance operation.



MaxX[®]

Double magnetic generator

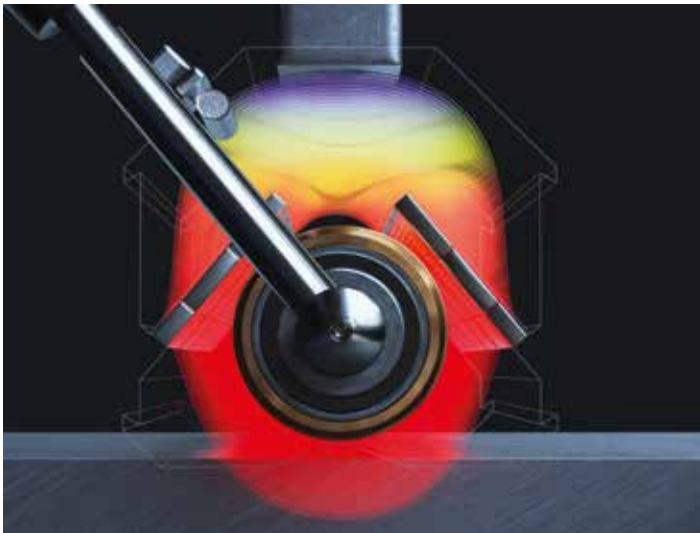

The flux generated by the high-energy permanent magnets placed in the stator slots is added to those inside the rotor for a **double magnetic force** extremely powerful to lift any type of workpiece in complete safety.

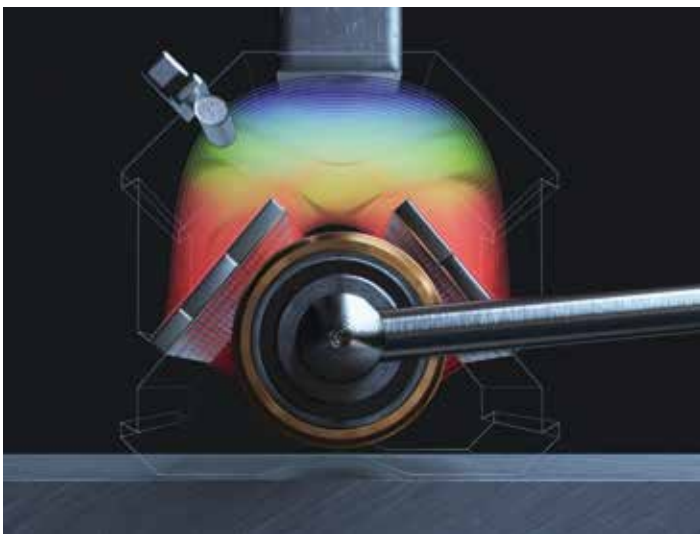

Rotating the lever to the rest position draws the entire magnetic flux inside the **MaxX** lifter, leaving the workpiece demagnetized without any residue. In addition, the perfect balance of the magnetic fields North/South inside the lifter prevents uncontrolled outflow of flux from the lifter body.



A “Smart Lever” at your service for safe magnetization

The path and intensity of the magnetic flux to clamp the workpiece to be lifted comes from a precise study on the angle of the stator magnets with that of the rotor.

The result is the “smart” behavior of the lever which informs the operator immediately through its soft or hard rotation whether the application is safe or risky due to unsuitable operating conditions such as a high air gap, too little thickness, a partial coverage of the magnetic poles or a material that is poorly permeable to magnetism.

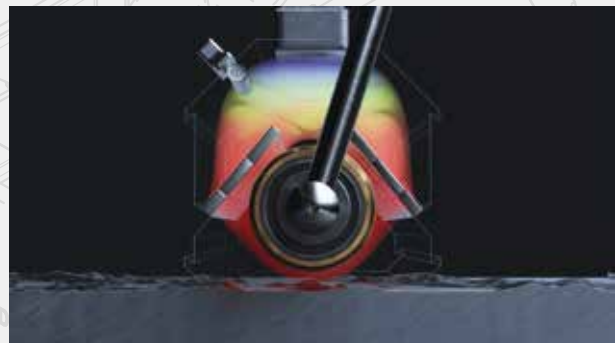
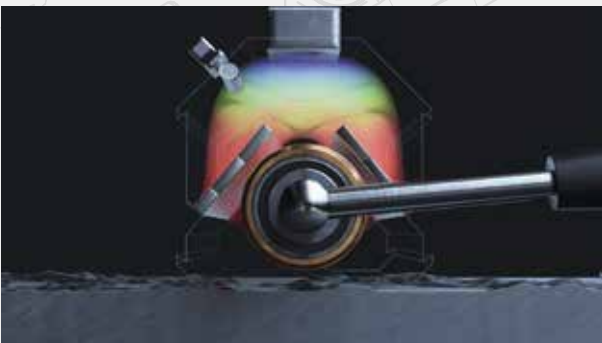

If the operating conditions are unsafe, the lever will not allow the activation of the magnetic force

A complete range for all needs

MaxX 125

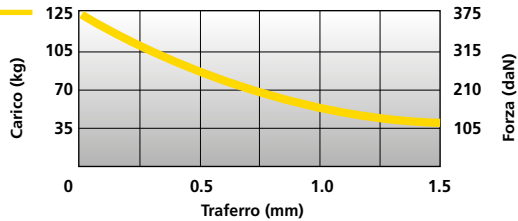

Flat loads		
Max load (WLL) (Kg)	Min. thick (mm)	Max length (mm)
125	20	1000

Round loads			
Max load (WLL) (Kg)	Min. thick (mm)	Max length (mm)	Ø max (mm)
50	10	1000	300

MaxX 200

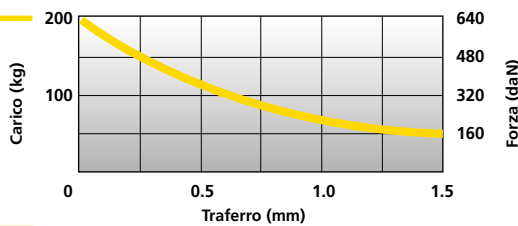

Flat loads		
Max load (WLL) (Kg)	Min. thick (mm)	Max length (mm)
200	20	1500

Round loads			
Max load (WLL) (Kg)	Min. thick (mm)	Max length (mm)	Ø max (mm)
80	10	1500	300

MaxX 250

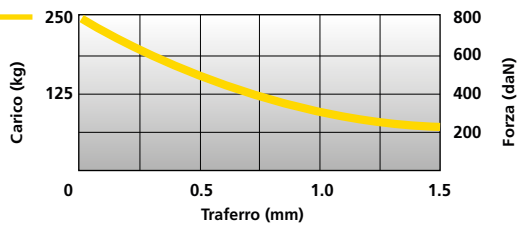

Flat loads		
Max load (WLL) (Kg)	Min. thick (mm)	Max length (mm)
250	20	1500

Round loads			
Max load (WLL) (Kg)	Min. thick (mm)	Max length (mm)	Ø max (mm)
100	10	1500	300

MaxX 300

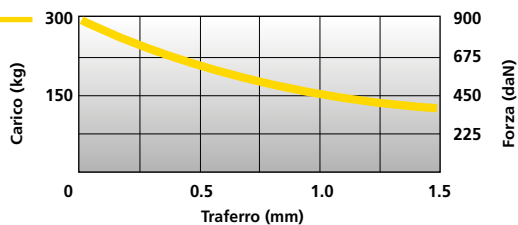

Flat loads		
Max load (WLL) (Kg)	Min. thick (mm)	Max length (mm)
300	20	1500

Round loads			
Max load (WLL) (Kg)	Min. thick (mm)	Max length (mm)	Ø max (mm)
120	10	1500	300

MaxX 500

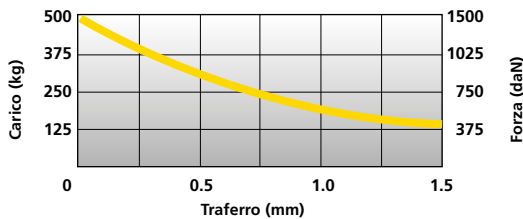

Flat loads		
Max load (WLL) (Kg)	Min. thick (mm)	Max length (mm)
500	25	2000

Round loads			
Max load (WLL) (Kg)	Min. thick (mm)	Max length (mm)	Ø max (mm)
200	15	2000	400

MaxX 600

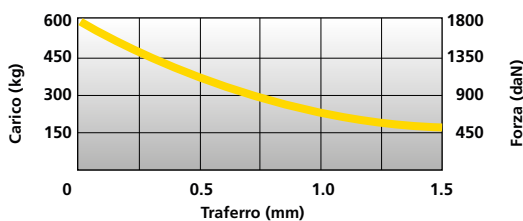

Flat loads		
Max load (WLL) (Kg)	Min. thick (mm)	Max length (mm)
600	25	2000

Round loads			
Max load (WLL) (Kg)	Min. thick (mm)	Max length (mm)	Ø max (mm)
240	15	2000	400

MaxX 1000

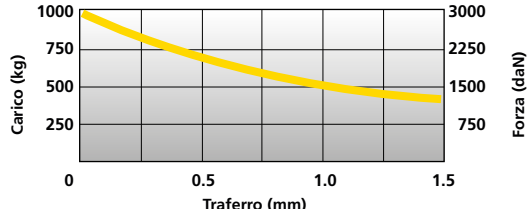

Flat loads			
Max load (WLL) (Kg)	Min. thick (mm)	Max length (mm)	
1000	40	3000	
Round loads			
Max load (WLL) (Kg)	Min. thick (mm)	Max length (mm)	Ø max (mm)
400	25	3000	450

MaxX 1500

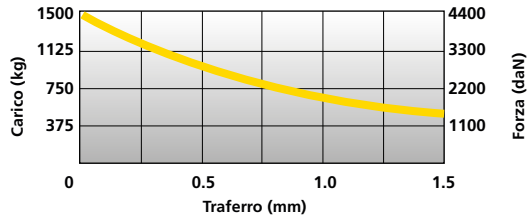

Flat loads			
Max load (WLL) (Kg)	Min. thick (mm)	Max length (mm)	
1500	45	3000	
Round loads			
Max load (WLL) (Kg)	Min. thick (mm)	Max length (mm)	Ø max (mm)
600	30	3000	500

MaxX 2000

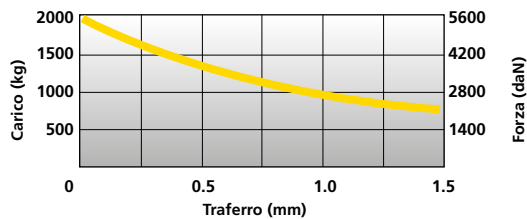

Flat loads			
Max load (WLL) (Kg)	Min. thick (mm)	Max length (mm)	
2000	55	3000	
Round loads			
Max load (WLL) (Kg)	Min. thick (mm)	Max length (mm)	Ø max (mm)
800	35	3000	600

MaxX TG 150

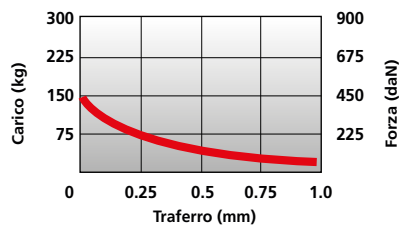

Flat loads			
Max load (WLL) (Kg)	Min. thick (mm)	Max length (mm)	
150	8	1500	
Round loads			
Max load (WLL) (Kg)	Min. thick (mm)	Max length (mm)	Ø max (mm)
50	8	1500	240

MaxX TG 300

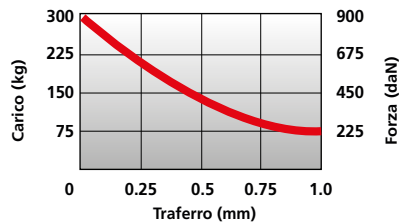

Flat loads			
Max load (WLL) (Kg)	Min. thick (mm)	Max length (mm)	
300	10	2000	
Round loads			
Max load (WLL) (Kg)	Min. thick (mm)	Max length (mm)	Ø max (mm)
100	10	2000	290

Data sheet

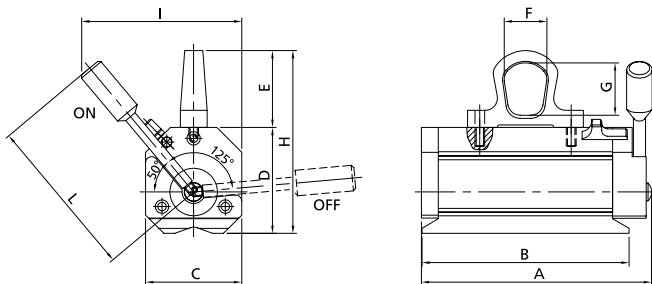

Model	Weight (Kg)	Dimensions (mm)									
		A	B	C	D	E	F	G	H	I	L
MaxX 125	3,5	119	69	79	79	66	30	37	145	130	132
MaxX 200	4,5	160	110	79	79	63	35	43	142	130	132
MaxX 250	6	190	143	79	79	63	35	43	142	130	132
MaxX 300	7,5	210	165	79	79	63	35	43	142	130	132
MaxX 500	15	250	199	106	101	88	52	60	189	174	176
MaxX 600	18	285	234	106	101	88	52	60	189	174	176
MaxX 1000	36	340	284	133	131	88	52	60	219	228	238
MaxX 1500	66	382	374	166	171	122	64	87	293	331	374
MaxX 2000	80	457	390	166	171	122	64	87	293	331	374
MaxX TG 150	6,8	191	143	79	91	63	35	43	154	130	132
MaxX TG 300	16	250	199	106	116	88	52	60	204	174	176

MFB - Magnetic Fixed beam

For handling bigger size loads using 2 hand controlled magnetic lifters.
MFB fits all MaxX models using 5 predefined centers distance depending on the size of the load.

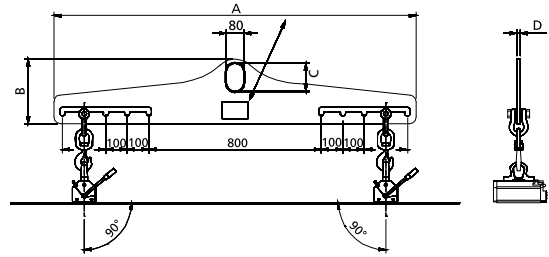
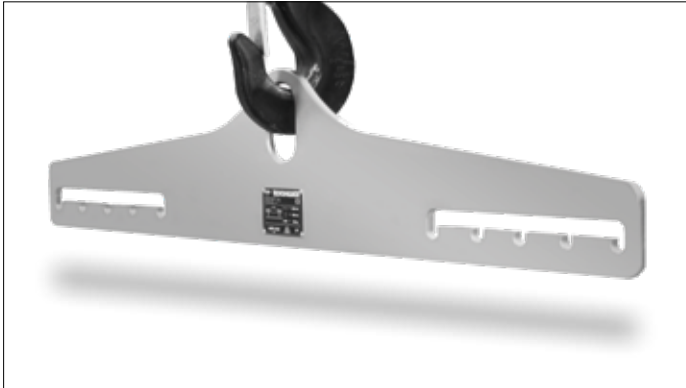

	A	B	C	D	Weight
	mm	mm	mm	mm	Kg
MFB 500	1680	300	130	15	37
MFB 2000	1900	415	160	18	75

MFB 500	Max lenght	Max width	Max load FLAT (WLL)	Max load ROUND (WLL)
	mm	mm	Kg	Kg
2 MaxX 250	3000	1500	400	200
2 MaxX 300	3000	1500	500	250
2 MaxX TG 150	3000	1500	200	100
2 MaxX TG 300	3000	1500	500	250

MFB 2000	Max lenght	Max width	Max load FLAT (WLL)	Max load ROUND (WLL)
	mm	mm	Kg	Kg
2 MaxX 500	3000	1500	800	400
2 MaxX 600	3000	1500	900	450
2 MaxX 1000	3000	1500	1.500	750
2 MaxX 1500	3000	1500	2.000	1.000
2 MaxX 2000	3000	1500	2.000	1.000

MVS - Magnetic Vertical System

For vertical handling of plates.
MVS suits to loads of various sizes by changing the position of the locking pins.

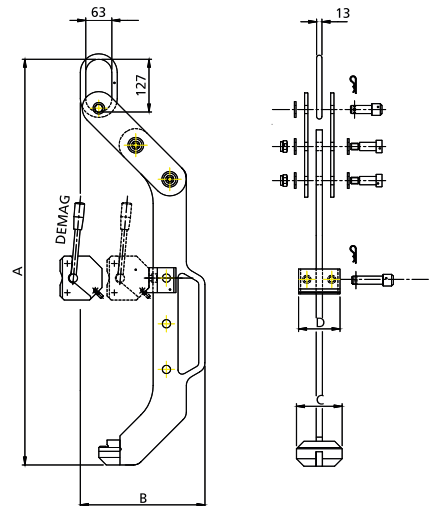
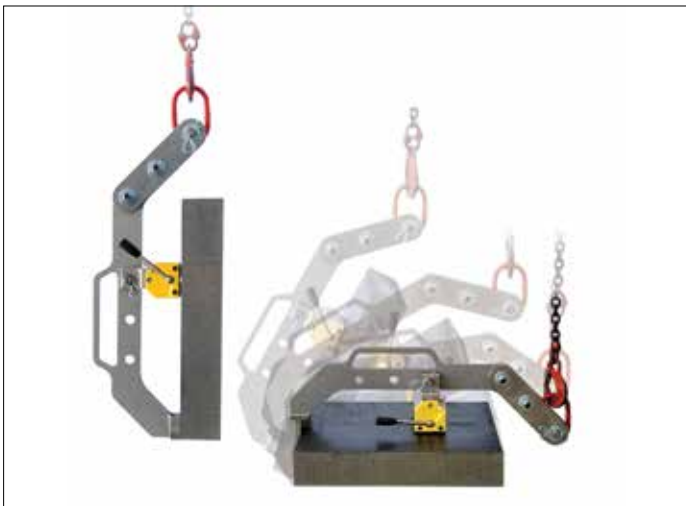

	MVS 250	MVS 500	MVS 1000
MaxX Model	250 - 300	500 - 600	1000
Max lenght	mm 800	1000	1000
Max height	mm 550	700	800
Max load	Kg 180	350	700

Dimensions and weights					
	A	B	C	D	Weight
	mm	mm	mm	mm	Kg
MVS 250	803	263	110	100	10
MVS 500	959	298	140	160	18
MVS 1000	1.058	330	140	160	19

MAXXI

Fixed beams for handling plates, rounds and profiles.

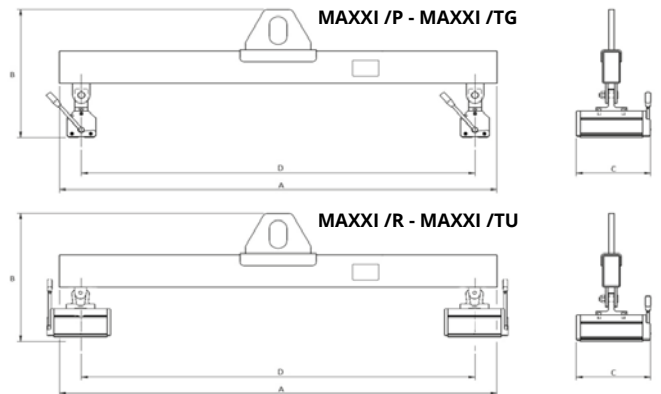

MAXXI /P

MAXXI /P for sheet and plate

Model	Equipped with 2 units	Min. thick	Width min. / max.	Lenght min. / max.	Max load
		mm	mm	mm	Kg
MAXXI 1000P	MaxX 500	25	250 / 1500	1000 / 4000	1000
MAXXI 2000P	MaxX 1000	40	300 / 2000	2000 / 5000	2000
MAXXI 3000P	MaxX 1500	45	350 / 2000	2000 / 5000	3000

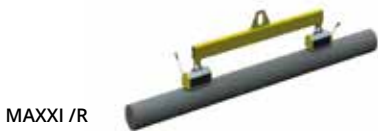

MAXXI /R

MAXXI /R for round loads

Model	Equipped with 2 units	Min. thick	Width min. / max.	Lenght min. / max.	Max load
		mm	mm	mm	Kg
MAXXI 1200R	MaxX 1500	30	45 / 500	2000 / 6000	1200



MAXXI /TU

MAXXI /TU for pipes

Model	Equipped with 2 units	Min. thick	Width min. / max.	Lenght min. / max.	Max load
		mm	mm	mm	Kg
MAXXI 240TU	MaxX 300TG	10	45 / 290	2000 / 6000	240



MAXXI /TG

MAXXI /TG for thin sheet

Model	Equipped with 2 units	Min. thick	Width min. / max.	Lenght min. / max.	Max load
		mm	mm	mm	Kg
MAXXI 300TG	MaxX 150TG	8	200 / 1500	1000 / 4000	300
MAXXI 600TG	MaxX 300TG	10	250 / 1500	1000 / 4000	600

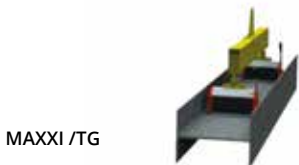

MAXXI /TG

MAXXI /TG for beams and profiles

Model	Equipped with 2 units	Min. thick	Width min. / max.	Lenght min. / max.	Max load
		mm	mm	mm	Kg
MAXXI 300TG	MaxX 150TG	8	300 / 1500	1000 / 6000	300
MAXXI 600TG	MaxX 300TG	10	330 / 1500	1000 / 6000	600

Dimensions and weights

Model	A	B	C	D	Weight
	mm	mm	mm	mm	Kg
MAXXI 1000/P	906	460	250	800	50
MAXXI 2000/P	2.000	640	340	1.800	110
MAXXI 3000/P	2.000	640	382	1.800	170
MAXXI 1200/R	2.210	680	500	1.800	170
MAXXI 240/TU	1.070	480	250	800	50
MAXXI 300/TG	880	450	190	800	40
MAXXI 600/TG	906	470	250	800	50





MAG-AUTOBLOK TECNOMAGNETE SpA
Headquarter



Via Nerviano 31 - 20045 Lainate (MI) - ITALY
 Tel.: +39 02 937591
 info@tecnomagnete.com
 www.mag-tecnomagnete.com

TECNOMAGNETE GmbH

Germany - Austria

Ohmstrasse 4 - 63225 Langen - GERMANY
 Tel.: +49 6103 750730 - Fax: +49 6103 750731
 Email kontakt@tecnomagnete.com

TECNOMAGNETE Inc.

U.S.A. - Canada - Mexico

6655 Allar Drive - Sterling Hts, MI 48312 - USA
 Tel.: +1 586 276 6001 - Fax: +1 586 276 6003
 Email infousa@tecnomagnete.com

TECNOMAGNETE SARL

France

Batiment C - 01200 VALSERHONE - FRANCE
 Tel.: +33 (0)4 50 56 06 00 - Fax: +33 (0)4 50 56 06 10
 Email contact@tecnomagnete.com