

**Please, read this manual
carefully before use!**

Owner's Manual



Inverter Generators

KS 2000iS CO
KS 2000iHS CO
KS 3200i CO
KS 4000iEHS CO
KS 6000iES CO
KS 6000iEHS CO

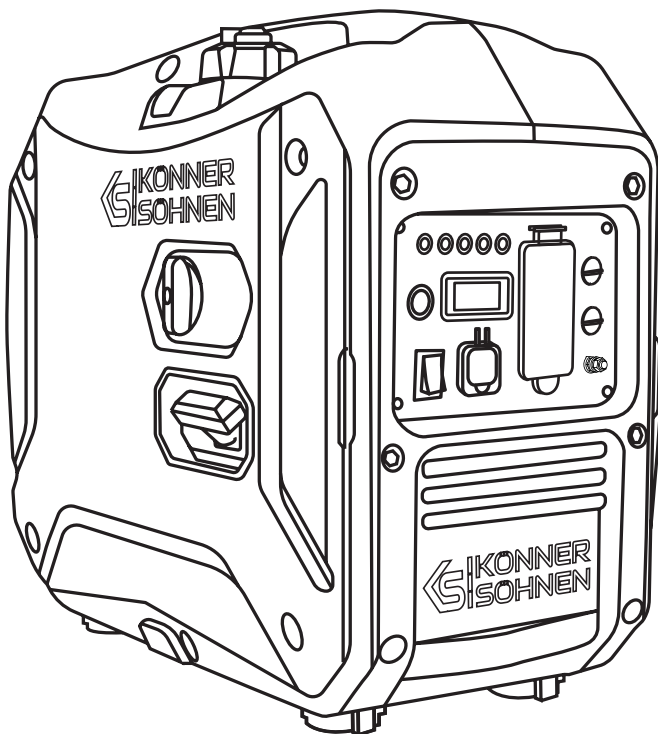



Thank you for your purchase of **Könnner & Söhnen®** products. This manual contains a brief description of safety, use and debugging. More information can be found on the official manufacturer's website in the support section: konner-sohnen.com/us

You can also go to the support section and download the full version of the manual by scanning the QR code, or on the website of the official importer of **Könnner & Söhnen®** products: konner-sohnen.com/us



We care about the environment, therefore, we consider it expedient to save paper and leave in print a short description of the most important sections.



Be sure to read the full version of the manual before getting started!



Manufacturer reserves the right to make alterations into the generators, which may not be reflected in this manual. Pictures and photos of the product may vary from its actual appearance. At the end of this manual, you may find contact information which you are free to use in case of any issues occurrence.

All data, specified in this operation manual is the most up to date for the moment of its publishing. The current list of service centers you can find at the website of official importer: konner-sohnen.com/us



ATTENTION – DANGER!



Failure to follow the recommendations marked with this sign may lead to serious injury or death of the operator or third parties.



IMPORTANT!



Useful information while operating the machine.

SAFETY INFORMATION

1

WORKING AREA



ATTENTION – DANGER!



When installing the generator, pay attention to the capacity of electrical appliances and their starting current, which may be several times higher than the rated current. The generator cannot run in overload conditions when starting consumers with an inrush current higher than the generator's maximum output.



ATTENTION – DANGER!



As exhaust gases contain poisonous carbon dioxide (CO₂) and carbon monoxide (CO) gases which are dangerous for life, it is strictly forbidden to install the generator in residential buildings, premises connected to residential buildings by a common ventilation system, other rooms from which exhaust gases may enter living premises. Use only outside and far away from windows, doors and vents! Never use inside of home or garage even if doors and windows are open!

- Do not use generator in the rain, snow and high humidity conditions, do not touch the generator with wet hands. It's prohibited to leave it in direct sunlight in summer for a long time. For storage of generator prepare a well ventilated area or store it under the canopy.

- Place the generator on a flat, hard surface, far away from flammable liquids/gases.

- Please don't use the generator near flammable gases, liquids or dust. When using the generator exhaust system gets very hot. This may cause fire or explosion of these materials.

- Be sure to follow cleanliness and good lighting in the work area. Clutter and poor lighting may cause an injury.
- Do not let the presence of unauthorized persons, children or animals when working with generator. If necessary, make sure to fencing the working area.
- Please use safety shoes and protective gloves when working with the generator. All personnel must wear ANSI approved safety goggles while setting up the generator.

ELECTRICAL SAFETY



ATTENTION – DANGER!



The device generates electricity. Follow safety precautions to avoid electric shock.



IMPORTANT!



KS 2000, KS 3200 and KS 4000 series generators are built as an IT system and have a floating neutral conductor. KS 6000 series generators have a neutral conductor bonded to the frame and shall not be operated without the grounding. The equipment grounding conductor terminals of the generators are bonding to the generator frame.

- The generator produces electricity that may lead to an electric shock while neglecting compliance regulations.
- Depending on the power supply system built with the generator (IT with floating neutral conductor or TN with the grounded neutral conductor), the required by NEC protective measures must be used. Premises wiring shall not be electrically connected to a supply system unless the latter contains, for any grounded conductor of the interior system, a corresponding conductor that is grounded. For the purpose of this section, electrically connected shall mean connected so as to be capable of carrying current, as distinguished from connection through electromagnetic induction.
- All connections between the generator and the House or groups of electric consumers must be made by certified electricians in accordance with all electrical rules and regulations.
- You can parallel generator only with another generator, which is applicable for this purpose and recommended by Könnner & Söhnen®.
- Do not allow moisture in the generator. The water inside the device increases the risk of an electric shock.
- In high humidity level conditions generator usage is prohibited. Keep the generator in a dry place only.
- Avoid direct contact with grounded surfaces (pipes, radiators, etc.).
- Be careful when working with power cables. Immediately replace it in case of damage, as damaged wire increases the risk of electric shock.
- Do not connect or disconnect a generator to electricity consumers, which are placed in water on wet or damp soil.
- Do not touch parts of the generator under voltage.
- Connect the generator to those customers only which meet the electrical characteristics and the rated power of the generator.
- Store all electrical equipment dry and clean. Wires with damaged or spoiled insulation should be replaced. You should also replace worn, damaged or rusty contacts.



IMPORTANT!



It is forbidden to use the generator as a replacement for public grid with on-grid or hybrid inverters, as the feed back can destroy the generator.

The generator and power consumers form a closed system, with elements affecting each other. This system is physically different from the public grid since it is significantly affected by factors such as unbalanced phase load and non-linear current consumption by power consumers that can cause damage to the generator and power consumers connected to it.

**IMPORTANT!****Using device for other purposes deprives the right for free warranty.****PERSONAL SAFETY**

- Be careful. Do not operate the generator – if you are tired, under the influence of drugs or alcohol. Inattention may cause a serious injury.
- Avoid inadvertent start. Make sure to set the switch to Off when you turn off the generator.

**ATTENTION – DANGER!****Noncompliance to these requirements may result in generator combustion or explosion, as well as in electric wiring ignition inside the structure.**

- Make sure no outside objects are on the generator when it is turned on. Using the device for other purposes deprives the right for free warranty. It is not allowed to sit or stand on the generator.
- Always keep a stable position and balance when starting the generator.
- Do not overload the generator, use it only for the purpose.

PRECAUTIONS WHEN WORKING WITH GASOLINE GENERATOR

- Do not start the generator operation upon presence of electric load. Disconnect the load before you stop the engine.
- Generator installation is to be performed at minimum 1 meter safety distance from flammable objects. All explosive and flammable materials or substances are to be kept away from the generator, for its engine produces heat during operation.
- Do not refuel the running generator. DO NOT overfill the fuel tank. Fuel expands when shaken or heated. ALWAYS leave ½ inch" space or more at the top of the tank.
- It is forbidden to smoke allow sparks, flames or any other sources of ignition around the generator.
- **Use unleaded gasoline with an octane rating of 87 or higher!** It is forbidden to use kerosene or other fuel types. It's acceptable to use gasoline with 10% bio-ethanol (E10). Carburetor and fuel piper have increased ethanol tolerance, nevertheless we do not recommend using E10, as it may lead to faster wear of the fuel pipes and carburetor.
- Observe the fuel tank refilling. Do not allow overfilling. After filling the tank, all excessive fuel spillage is to be removed from the surface.
- It is forbidden to touch the exhaust system during the generator start and during their process of its running.
- It is forbidden to run the generator in cases when its exposure to rain, snow and possibility of soakage exists.
- Before running the generator, it is necessary to define the place and means of its emergency stop.

**ATTENTION – DANGER!****Fuel contaminates the land and groundwater. Do not allow the leaking gasoline from the tank!****PRECAUTIONS WHEN WORKING WITH HYBRID GENERATOR****IMPORTANT!****For dual fuel models, only propane for cars (LPG) can be used as gas! It is forbidden to use any other gas!**

- Do not start the generator operation upon presence of electric load! Disconnect the load before you stop the engine.
- You are allowed to connect all the power consuming supplies only after the generator has warmed up. If you start generator with appliances being connected the engine may work in an unstable condition due to the fuel remains in the carburetor.

- Disconnect the load before you stop the engine, disconnect all the connected devices first, then close the gas valve, then turn off the engine. After that, set the starter switch to OFF position and turn off the gas supply valve.
- Before usage make sure, that all the hoses are connected properly.
- In case of gas leakage, stop the gas flow from the source to generator and switch off all the electric appliances connected as soon as possible.
- For stopping gas powered engine: disconnect all the connected devices first, then close the gas valve, then turn off the engine. After that, set the starter switch to OFF position and turn off the gas supply valve.



ATTENTION - DANGER!



Do not allow sparks near gas powered generator during its operation.



ATTENTION - DANGER!



The gas cylinder valve must not be closed when the generator is not running. The generator must not be operated on gas in basements.



ATTENTION - DANGER!



Pay attention! Usage of gasoline together with liquefied gas is forbidden! When you operate using gasoline, you must stop LPG supply. When you operate generator using LPG - you must stop gasoline supply.

SAFETY SYMBOLS DECRYPTION

2

SYMBOLS DESCRIPTION WHEN WORKING WITH GENERATOR

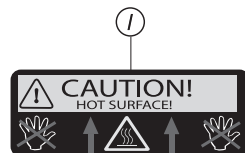

- A.** Be careful when using the device! Follow safety rules listed in manual.
- B.** Keep children out of the generator area.
- C.** Do not use or store the device in high humidity.
- D.** Do not smoke when using the generator!
- E.** The device generates electricity. Follow safety precautions to avoid electric shock.
- F.** Carefully read the manual before using the device.
- G.** Do not touch the generator with wet or dirty hands.
- H.** Follow fire safety rules, do not use open flames near the generator.
- I.** Please don't touch! The muffler heats up when running the generator.

BESIDES SAFETY SYMBOLS GENERATOR CONTAINS FOLLOWING INSCRIPTION:

⚠ DANGER

Using a generator indoors **CAN KILL YOU IN MINUTES!**
 Generator exhaust contains carbon monoxide.
 This is a poison you cannot see or smell.

NEVER use inside a home or garage. **EVER** if doors and windows are open.

ONLY use **OUTSIDE** and far away from windows, doors, and vents.

Avoid other generator hazards. **READ MANUAL BEFORE USE.**

⚠ PELIGRO

El uso de un generador en interiores **PODE MATARLO EN MINUTOS!**
 El escape del generador contiene monóxido de carbono. Este es un veneno que no se puede ver ni oler.

Nunca lo use dentro del hogar ni el garaje. **NI UNO** si las puertas y ventanas están abiertas.

Úsalo **SOLO** en el **INTERIORE** lejos de ventanas, puertas, y otros sitios de ventilación.

Evite otros peligros del generador. **LEA EL MANUAL ANTES DE USARLO.**

Using generator indoors can kill you in minutes! Generator exhaust contains carbon monoxide. This is a poison you cannot see or smell. Never use inside a home or garage. Even if doors and windows are open. Only use outside and far away from windows, doors, and vents.

KONNER SOHNEN KS 4000IEHS CO INVERTER GENERATOR GENERADOR INVERSOR

RATED POWER POTENCIA NOMINAL	3500W*	FREQUENCY FRECUENCIA	60Hz	ENGINE POWER POTENCIA DEL MOTOR	7.5HP
MAX POWER POTENCIA MAXIMA	4000W*	VOLTAGE VOLTAJE	120V	YEAR OF ISSUE	2023
POWER FACTOR FACTOR DE POTENCIA Cosφ	1	WEIGHT PESO	88 lbs (50)		

*The generator reduces power by 10% Operation de GP reduce la potencia del generador en un 10%
 Konner & Sohnen, manufactured under license and control of Dimax International GmbH, Flinger Broich 203, 40235 Duesseldorf, Germany. Made in China.
 Official importer and representative in the USA: KS Energy Solutions, Inc. Balkness Drive, STE. 100, Austin, TX 78721, USA. www.konner-sohnen.com/us

Specification table.
 For different models this table is different.
 All characteristics are given in the "Specifications".

UNLEADED FUEL ONLY!

ÚNICAMENTE GASOLINA SIN PLOMO

We strongly recommend to use unleaded fuel with octane rating of 87 or higher. It's acceptable to use gasoline with 10% bio-ethanol (E10). Carburetor and fuel piper have increased ethanol tolerance, nevertheless we do not recommend using E10, as it may lead to faster wear of the fuel pipes and carburetor.



Information on the required level of oil is in the crankcase.

MAINTAIN AIR FILTER!

⚠ Clean up in cleansing solvent (not flammable) and dry up once every 50 hours (every 10 hours in usually dusty conditions) and then immerse in clean engine oil until saturated, squeeze out excessive oil.

⚠ La limpieza del filtro de aire debe realizarse cada 50 horas de funcionamiento del generador (cada 10 horas en caso de condiciones inusualmente polvorientas).

Air filter cleaning is to be performed each 50 hours of the generator operation (every 10 hours in unusually dusty conditions).

Recommended maintenance schedule Should be done every month or over a certain number of hours (depending on what comes first)	Every start	First month or 20 hours	Every 3 months or 50 hours	Every 6 months or 100 hours	Every year or 300 hours
Motor oil Check the level Replace	X	X	X		
Air filter Check Clean out Replace	X	X	X	X	
Spark plug Check/Clean out Replace		X	X	X	
Fuel tank Check the level Clean out	X				X
Fuel filter Check		X	X		

* Clean out more often in dusty conditions
 ** Maintenance should be done only by authorized specialist

READ MANUAL

Maintenance information translated into the language of the country where the generator is sold you may find in "Maintenance".



Grounding

**TAKE IT
OUTSIDE™**

WWW.TAKEYOURGENERATOROUTSIDE.COM

PGMA
Portable Generator Manufacturers' Association**CARBON MONOXIDE SAFETY: THE BIG PICTURE**

Taking your generator outside is the only safe way to use it. It is absolutely mandatory for keeping your family safe from carbon monoxide, which is a colorless, odorless threat. There are other things to know about generator safety including potential electrical hazards. By educating yourself about all risks, you'll be better prepared to protect yourself, your family, and others.

www.TakeYourGeneratorOutside.com**1. ALWAYS READ THE OPERATOR'S MANUAL FIRST****2. KNOW THE SYMPTOMS**

- HEADACHE
- NAUSEA
- SHORTNESS OF BREATH
- DIZZINESS
- FATIGUE

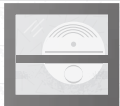
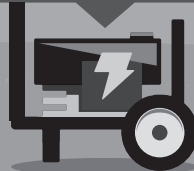
**IF YOU FEEL SYMPTOMS,
LEAVE RIGHT AWAY****3. STAY ALERT WITH CARBON MONOXIDE DETECTORS****4. PROTECT LINE WORKERS FROM BACKFEED. INSTALL A TRANSFER SWITCH BEFORE CONNECTING A GENERATOR DIRECTLY TO HOUSEHOLD WIRING.****5. CHOOSE GENERATORS WITH CO SHUT OFF SYSTEMS THAT MEET ANSI/PGMA G300-2018 STANDARD REQUIREMENTS****6. KEEP IT OUTSIDE AND FAR AWAY FROM DOORS AND WINDOWS****7. POINT FUMES AWAY FROM HOME AND PEOPLE**

MODELS KS 2000IS CO, KS 2000IHS CO

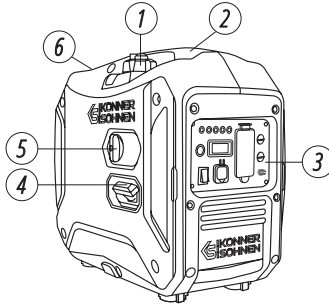

1. Fuel tank cap air vent
2. Carrying handles
3. Control panel
4. Manual starter
5. Air choke (for model KS 2000IS CO). Fuel switch for model KS 2000IHS CO. Model KS 2000IHS CO has an air choke located on its control panel.
6. Maintenance cover (on the other side of the generator)

MODEL KS 2000IS CO

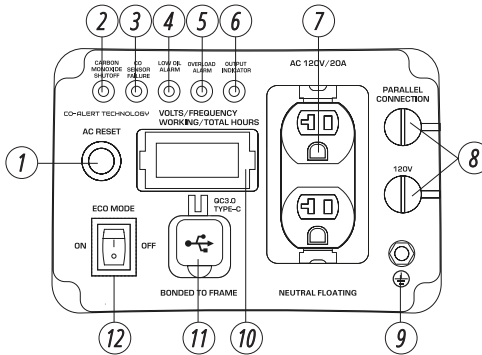

FOR MODELS
KS 2000IS CO AND KS 2000IHS CO

1. Reset button
2. Carbon monoxide shutoff
3. CO sensor failure
4. Oil level indicator
5. Overload indicator
6. Output indicator
7. 2*AC 120V 20A
8. Generator parallel outputs
9. Earthing bolt
10. LED display
11. QC3.0 Type-C
12. Eco mode (Economy mode)
13. Engine switch

MODEL KS 2000IHS CO

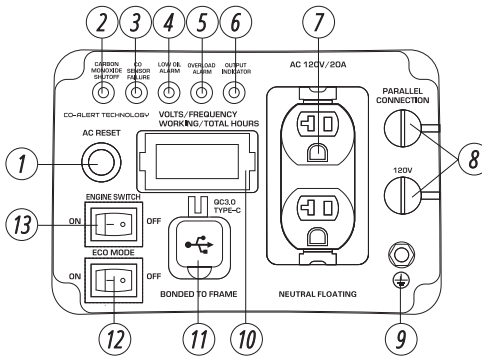

IMPORTANT!



Manufacturer reserves the right to make changes and/or improvements in design, components set and technical attributes without notice and without incurring obligation. The pictures in this manual are schematic and may not match the parameters of original product.

MODEL KS 3200i CO

1. Manual starter
2. Frame
3. Fuel tank cap
4. Control panel
5. Oil-depth gage

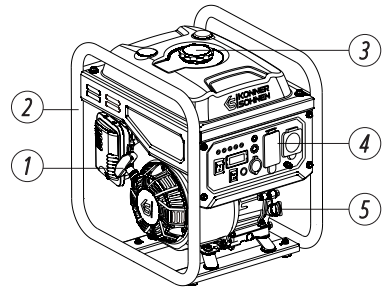

1. Carbon monoxide shutoff
2. CO sensor failure
3. Oil level indicator
4. Overload indicator
5. Output indicator
6. AC1 circuit breaker
7. 2*AC1 120V 20A
8. AC2 120V 30A
9. Earthing bolt
10. DC circuit breaker
11. 12V/8.3A DC outlet
12. Reset button
13. LED display
14. Eco mode (Economy mode)
15. Engine switch

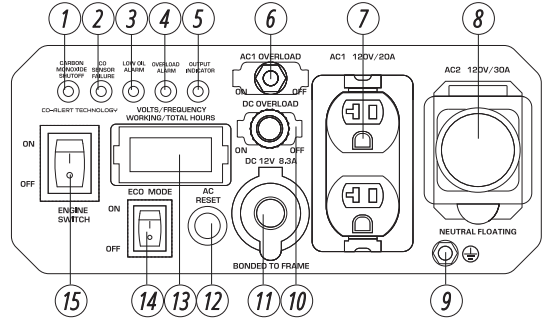

MODEL KS 4000iEHS CO

1. Fuel tank cap
2. Carrying handles
3. Control panel
4. Manual starter
5. Transport wheels
6. Maintenance cover
7. Multifunction engine switch

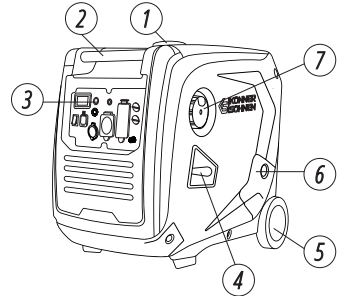

1. Eco mode (Economy mode)
2. Multifunctional LED display
3. Reset button
4. AC circuit breaker
5. 2*AC1 120V 20A
6. Generator parallel outputs
7. Earthing bolt
8. AC 120V 30A
9. 12V/8.3A DC outlet
10. DC circuit breaker
11. QC3.0 Type-C
12. Battery charging port

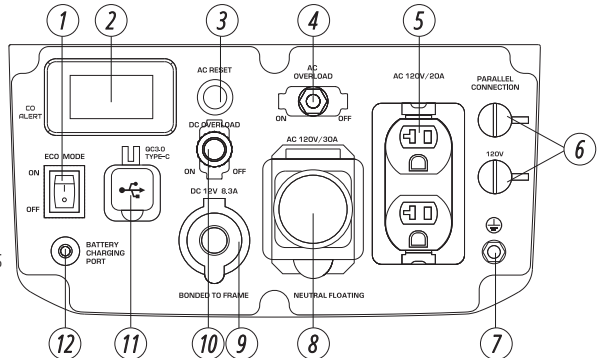

MODELS KS 6000iES CO, KS 6000iES CO

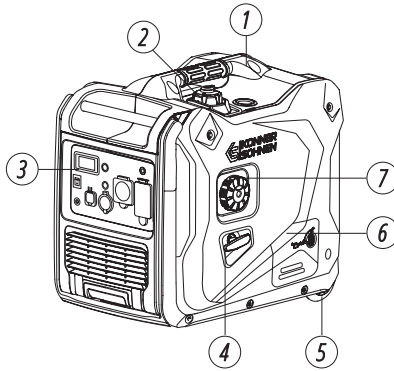

1. Carrying handle
2. Fuel tank cap air vent
3. Control panel
4. Recoil starter
5. Transport wheels
6. Maintenance cover
7. Multifunction engine switch

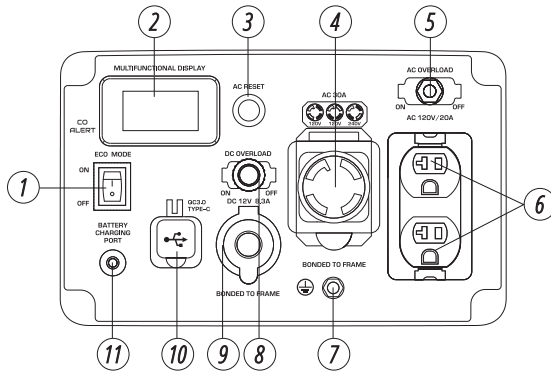

- | | |
|--------------------------------|---------------------------|
| 1. Eco mode (Economy mode) | 7. Earthing bolt |
| 2. Multifunctional LED display | 8. DC circuit breaker |
| 3. Reset button | 9. 12V/8.3A DC outlet |
| 4. AC 120V/240V 30A | 10. QC3.0 Type-C |
| 5. AC circuit breaker | 11. Battery charging port |
| 6. 2*AC 120V 20A | |



IMPORTANT!



Manufacturer reserves the right to make changes and/or improvements in design, components set and technical attributes without notice and without incurring obligation. The pictures in this manual are schematical and may not match the parameters of original product.

1. Generator
2. Packaging
3. Operating instructions

Generator is equipped with additional accessories:
spark plug wrench, PH2 screwdriver 0.24 in, filling funnel,
dual USB car charger (for model KS 3200i CO).



In addition to the components shown in the figure of a gasoline generator, a generator with a hybrid system (LPG/ gasoline) is equipped with a 1.5 m (4.9 ft) cylinder connection hose for supplying LPG to the generator.

Connect the LPG hose to the LPG input.



for model KS 2000iHS CO

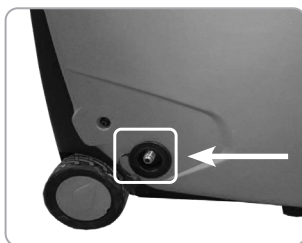

for model KS 4000iEHS CO

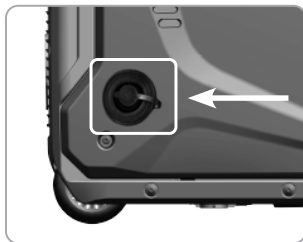

for model KS 6000iEHS CO

Model	KS 2000iS CO	KS 2000iHS CO
Voltage	120 V	
Maximum power	2000 W	2000 W*
Nominal power	1800 W	1800 W*
Frequency	60 Hz	
Current	17 A (max.)	17 A (max.)
Outlets	2*20A	2*20A
Engine start	recoil	recoil
Fuel tank volume	1.3 gal. (5L)	1.3 gal. (5L)
Run time @50% (gasoline)**	5 h	5 h
LED display	voltage, frequency, working hours	
Noise level Lpa (23 ft.)	57 dB	57 dB
Output 12V	-	-
Carbon monoxide shutoff	+	+
QC3.0 Type-C	+	+
Engine model	KS 100i	KS 100i-H
Engine volume	79.7 cc	79.7 cc
Engine type	gasoline, 4 stroke cycle engine	LPG/gasoline 4 stroke cycle engine
Engine power	3.3 hp	3.3 hp
Generator parallel outputs	+	+
Crankcase volume	13 fl. oz (0.4L)	13 fl. oz (0.4L)
Power factor, cos φ	1	1
Dimensions (LxWxH)	21.8"*13.2"*21.2"	27.5"*13.2"*21.2"
Lithium battery	-	-
Net weight	41.8 lbs	41.8 lbs
Protection class	IP23M	
Engine cooling typ	forced air	
Frequency regulation	inverter	
Nominal voltage tolerance – max. 5%		

*LPG operation reduces generator power by 10%.

**Fuel consumption depends on many factors, such as load, fuel quality, season, altitude, technical condition of the generator.

To ensure reliability and increase the engine service life, peak powers may be slightly limited by circuit breakers.

The optimal operating conditions are ambient temperature of 63–77 °F, barometric pressure of 0.1 MPa (760 mm Hg), and relative humidity of 50-60%. Under these environmental conditions, the generator can provide maximum performance in terms of the declared specifications.

In the event of deviations from these environmental indicators, the generator performance may vary.

Please note that continuous loads exceeding 80% of the generator's rated power are not recommended in order to extend its service life.

Model	KS 3200i CO	KS 4000iEHS CO
Voltage	120 V	
Maximum power	3200 W	4000 W*
Nominal power	3000 W	3500 W*
Frequency	60 Hz	
Current	26 A (max.)	33 A (max.)
Outlets	2*20A, 1*30A	2*20A, 1*30A
Engine start	recoil	recoil/electric
Fuel tank volume	1.8 gal. (7L)	3.2 gal. (12L)
Run time @50% (gasoline)**	4.7 h	7.8 h
LED display	voltage, frequency, working hours	multifunctional LED display***
Noise level Lpa (23 ft.)	-	62 dB
Output 12V	12V/8.3A	12V/8.3A
Carbon monoxide shutoff	+	+
QC3.0 Type-C	-	+
Engine model	KS 210i	KS 240i-H
Engine volume	208 cc	223 cc
Engine type	gasoline, 4 stroke cycle engine	LPG/gasoline 4 stroke cycle engine
Engine power	5.5 hp	7.5 hp
Generator parallel outputs	-	+
Crankcase volume	20 fl. oz (0.6L)	20 fl. oz (0.6L)
Power factor, cos φ	1	1
Dimensions (LxWxH)	17.5**14.8**17.9"	27.5**18.7**22.4"
Lithium battery	-	1.6 Ah
Net weight	56.1 lbs	88 lbs
Protection class	IP23M	
Engine cooling typ	forced air	
Frequency regulation	inverter	
Nominal voltage tolerance – max. 5%		

*LPG operation reduces generator power by 10%.

**Fuel consumption depends on many factors, such as load, fuel quality, season, altitude, technical condition of the generator.

***Multifunctional LED-display: output power, frequency, voltage, working hours, fuel level; CO sensor failure, carbon monoxide shutoff, low oil alarm, overload alarm, output indicator.

To ensure reliability and increase the engine service life, peak powers may be slightly limited by circuit breakers.

The optimal operating conditions are ambient temperature of 63–77 °F, barometric pressure of 0.1 MPa (760 mm Hg), and relative humidity of 50-60%. Under these environmental conditions, the generator can provide maximum performance in terms of the declared specifications.

In the event of deviations from these environmental indicators, the generator performance may vary.

Please note that continuous loads exceeding 80% of the generator's rated power are not recommended in order to extend its service life.

Model	KS 6000iES CO	KS 6000iEHS CO
Voltage	120V/240V 30A	
Maximum power	5500 W	5500 W*
Nominal power	5000 W	5000 W*
Frequency	60 Hz	
Current	23 A (max.)	23 A (max.)
Outlets	2*20A, 1*30A (120V/240V)	2*20A, 1*30A (120V/240V)
Engine start	recoil/electric	recoil/electric
Fuel tank volume	2.9 gal. (11L)	2.9 gal. (11L)
Run time @50% (gasoline)**	6.8 h	6.8 h
LED display	multifunctional LED display***	
Noise level Lpa (23 ft.)	64 dB	64 dB
Output 12V	12V/8.3A	12V/8.3A
Carbon monoxide shutoff	+	+
QC3.0 Type-C	+	+
Engine model	KS 240I-1	KS 240I-H1
Engine volume	223 cc	223 cc
Engine type	gasoline, 4 stroke cycle engine	LPG/gasoline 4 stroke cycle engine
Engine power	9.0 hp	9.0 hp
Generator parallel outputs	–	–
Crankcase volume	24 fl. oz (0.7L)	24 fl. oz (0.7L)
Power factor, cos φ	1	1
Dimensions (LxWxH)	24.4**16.7**23.6"	28**16.7**23.6"
Lithium battery	1.6 Ah	1.6 Ah
Net weight	86.9 lbs	86.9 lbs
Protection class	IP23M	
Engine cooling typ	forced air	
Frequency regulation	inverter	
Nominal voltage tolerance – max. 5%		

*LPG operation reduces generator power by 10%.

**Fuel consumption depends on many factors, such as load, fuel quality, season, altitude, technical condition of the generator.

***Multifunctional LED-display: output power, frequency, voltage, working hours, fuel level; CO sensor failure, carbon monoxide shutoff, low oil alarm, overload alarm, output indicator.

To ensure reliability and increase the engine service life, peak powers may be slightly limited by circuit breakers.

The optimal operating conditions are ambient temperature of 63–77 °F, barometric pressure of 0.1 MPa (760 mm Hg), and relative humidity of 50-60%. Under these environmental conditions, the generator can provide maximum performance in terms of the declared specifications.

In the event of deviations from these environmental indicators, the generator performance may vary.

Please note that continuous loads exceeding 80% of the generator's rated power are not recommended in order to extend its service life.

TERMS OF USE OF INVERTER GENERATOR

8

It is recommended to ground the generator before operating it for the first time. Before starting the device, remember that the total power of the connected power consumers should not exceed the nominal power of the generator.



IMPORTANT!



Depending on the power supply system built with the generator (IT with floating neutral conductor or TN with the grounded neutral conductor), the required by NEC protective measures must be used.

Premises wiring shall not be electrically connected to a supply system unless the latter contains, for any grounded conductor of the interior system, a corresponding conductor that is grounded. For the purpose of this section, electrically connected shall mean connected so as to be capable of carrying current, as distinguished from connection through electromagnetic induction.



IMPORTANT!



Make sure that the control panel, the blinds and the underside of the inverter are well cooled and protected against the ingress of small solids, dirt, and water. Improper operation of the cooler can cause damage to the motor, inverter, or alternator.

GENERATOR OPERATION

9

OIL LEVEL INDICATOR

When the oil level falls below the level required for operation, the oil level indicator lights up, and then the engine stops automatically. The engine will not start until oil is added.

AC INDICATOR

When the generator is running and producing electricity, the AC indicator light is on.

DC CIRCUIT BREAKER

The DC protector automatically switches to "OFF" when the current of the operating electrical device is higher than the rated current. To use this equipment again, turn on the DC circuit breaker again by pressing the "ON" button.



IMPORTANT!



If the DC circuit breaker turns off, reduce the load of the connected electrical device. If the DC protector turns off again, stop operation and contact your nearest Könnér & Söhnen service center.

OVERLOAD INDICATOR

The overload indicator lights up when the connected generator is overloaded, the inverter control unit overheats or the AC output voltage rises.

If the overload indicator goes on, the engine will continue to operate, but the generator will no longer produce electricity. In this case, you must perform the following steps:

1. Turn off all connected electrical appliances and stop the engine.
2. Reduce the total power of the connected devices until the nominal power of the generator is reached.
3. Check if the vent grid is clogged. Remove excess dirt or debris, if any.
4. After checking, start the engine.



IMPORTANT!



The overload indicator may light up within several seconds after start-up or when connecting electrical devices requiring a high starting current, such as a compressor or voltage indicator. However, this is not a malfunction.

CARBON MONOXIDE SHUTOFF

Flashing red light: dangerous levels of carbon monoxide gas have built up leave immediately until area has aired out. Move generator to well-ventilated area before operation. The CO sensor monitors for the accumulation of poisonous carbon monoxide gas around the generator when the engine is running. If increasing levels of CO gas are detected, the CO Sensor automatically shuts down the engine.

CO SENSOR FAILURE

Flashing yellow light: carbon monoxide sensor malfunction, sensor needs service.

MULTIFUNCTIONAL LED DISPLAY (FOR MODELS KS 4000IEHS CO, KS 6000IES CO, KS 6000IEHS CO)

1. Output power
2. Output frequency
3. Output voltage
4. Total working hours
5. Carbon monoxide shutoff
6. Working hours each time
7. Low oil alarm
8. CO sensor failure
9. Residual fuel
10. Maintenance reminder - will flash once after accumulated 50 working hours. It will flash once after each 50 working hours
11. Overload alarm
12. Output indicator

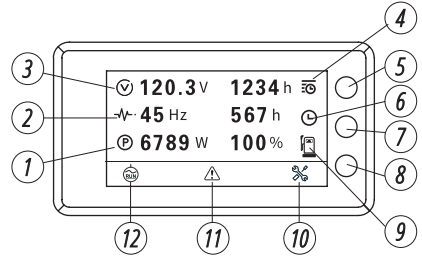
**FUEL TANK CAP AIR VENT (FOR MODEL KS 2000iS CO, KS 2000iHS CO)**

The fuel cap is equipped with a vent for air supply to the fuel tank. When the engine is running, the vent must be in the "ON" position (OPEN). This will allow fuel to enter the carburetor for engine operation. After the generator stops, allow it to cool down and close the air vent on the fuel cap. When the generator is not in use, close the vent to the "OFF" position.

EARTHING BOLT

In all cases, except for an IT system with an insulated neutral wire and bonding, the generator earthing bolt must be connected to the grounding circuit with a flexible copper conductor with a cross-sectional area of at least 6 mm².

CHECK BEFORE GETTING STARTED**10****CHECKING THE FUEL LEVEL**

1. Unscrew the fuel cap and check the fuel level in the tank.
2. Fill the fuel tank to the fuel filter level.
3. Tighten the fuel cap securely.
4. For models in a soundproof canopy, open the air intake vent on the fuel cap.

Recommended fuel: fill in only fresh, unleaded fuel with an octane rating 87 or higher.

Fuel tank volume: see specifications table.

**IMPORTANT!**

Wipe up spilled fuel immediately with a clean, dry, soft cloth, as the fuel may harm painted surfaces or plastic parts.

**IMPORTANT!**

We strongly recommend to use unleaded fuel with octane rating 87 or higher. It's acceptable to use gasoline with 10% bio-ethanol. Carburetor and fuel piper have increased ethanol tolerance, nevertheless we do not recommend using E10, as it may lead to faster wear of the fuel pipes and carburetor.

CHECKING THE OIL LEVEL

The generator is transported free of motor oil. Do not start the engine until it is filled with an sufficient amount of motor oil.

1. Open the service cover (fig.1).
2. Unscrew the oil dipstick (fig. 2) and wipe it out with a clean cloth.
3. Fill the crankcase with engine oil. The recommended amount of oil for each model is indicated in the specification chart.
4. Insert the dipstick without screwing it in.
5. Check the oil level by a mark on the oil dipstick.
6. Add oil if its level is below the mark on the oil dipstick.
7. Screw on the dipstick.

Recommended motor oil: SAE 10W-30.

Recommended motor oil grade: API Service SG type or higher.

Motor oil quantity: see specifications table.



Fig. 1

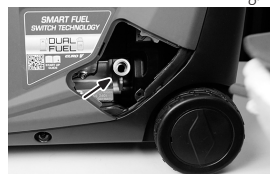

Fig. 2

GETTING STARTED

11

Before starting the engine, make sure that the rated power of power consumers matches with the power of generator. Do not exceed the nominal power of the generator. **Do not connect any devices before you start the engine!**



IMPORTANT!



Do not change the controller settings in terms of the amount of fuel or speed governor (this adjustment was made at the factory). Otherwise, this may result in changes in the engine operation or its failure.



ATTENTION – DANGER!



In the power supply mode, the generator should operate no longer than 1 minute in the range from nominal to maximum power.



ATTENTION – DANGER!



Generators should not run continuously (e.g. by adding fuel to the tank or connecting a large fuel tank) or longer than recommended: 4-6 hours for LPG/gasoline or gasoline generators (depending on load).

This material is for informational purposes only and does not constitute a manual for installing the equipment or connecting it to the mains, but we strongly recommend that you read the instructions below. Equipment connection must always be carried out by a certified electrician responsible for the installation and electrical connection of the equipment according to local laws and regulations. The manufacturer assumes no liability for improper connection of the equipment or for any material or physical damage that may result from improper installation, connection or operation of the equipment.

COMMISSIONING

1. Fill the crankcase with engine oil. The recommended amount of oil for each model is indicated in the specification chart.
2. Check oil level with an oil dipstick. It should be between the MIN and MAX marks on the oil dipstick.
3. Check fuel level. Add unleaded fuel in the fuel tank if fuel level is insufficient.
4. Check the air filter for correct installation.
5. The recommended LPG tank size is the one which could fill LPG at least 11 lbs.

IN THE FIRST 20 OPERATING HOURS OF THE GENERATOR, THE FOLLOWING REQUIREMENTS SHOULD BE MET:

1. During commissioning, do not connect power consumers, the power of which exceeds 50% of the nominal (operating) power of the device.

2. After the first 20 operating hours, be sure to change the oil. It is better to drain oil while the engine is still hot after operation to ensure quick and complete oil draining. Be careful while draining the oil, it's extremely hot! Wait about 10 minutes after the shutdown and drain the oil being extremely careful!
3. Check and clean the air filter, fuel filter and spark plug.



IMPORTANT!



Before starting the generator, connect the ground wire to the ground terminal.

Generators, which are equipped with battery, are shipped with terminals disconnected to prevent battery self-discharge during storage. To connect the battery terminals open the service cover and connect terminals ensuring the correct polarity (“+” to “+”, “-” to “-”). For example, see pictures below how to make it for model KS 4000iEHS CO:



1. Open the service cover.

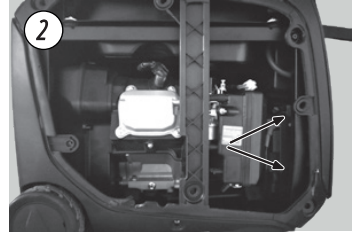

2. Connect the terminals ensuring the correct polarity (“+” to “+”, “-” to “-”).

ENGINE START



IMPORTANT!



Useful tip: If the engine stalls or does not start, turn the engine switch to the “ON” position, and then pull the manual starter. If the oil level indicator flickers for several seconds, add oil and restart the engine.



IMPORTANT!



Each time you start the generator, be sure to check oil and fuel level.

TO START GENERATOR KS 2000iS CO

1. Check oil level.
2. Check fuel level. Add unleaded fuel in the fuel tank if fuel level is insufficient.
3. Open the vent on the fuel cap to the “ON” position (fig. 3).
4. Turn the air choke control knob to the “START” position (fig. 4).
5. Pull the manual starter until a slight resistance is felt, then pull it toward you relatively sharply. Slowly turn the manual starter by hand, do not release it abruptly.
6. Turn the air choke control knob to the “RUN” position (fig. 4).

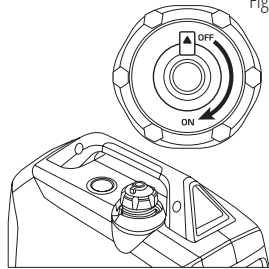

Fig. 3

TO START LPG/GASOLINE GENERATOR KS 2000iHS CO IN GASOLINE MODE:

1. Close the gas valve on the cylinder.
2. Open the vent on the fuel cap to the “ON” (fig. 3).
3. Set the fuel switch to “ON” and close the air choke on the control panel.
4. Start the engine (pull the starter cord to the full length with a sharp movement. The generator will start. If this is not the case, repeat this action. Slowly turn the manual starter by hand, do not release it abruptly).
5. Open the air choke by pushing the air choke handle.

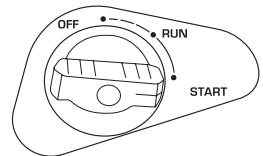

Fig. 4

TO START LPG/GASOLINE GENERATOR KS 2000iHS CO IN LPG MODE:

1. Check oil level.
2. Connect the LPG hose to the LPG input (connect hose end **A** to the LPG input, as shown in Fig. 5).
3. Connect the hose end with the reducer to the gas cylinder (connect hose end **B** to the gas cylinder, as shown in Fig. 5).
4. Close the air choke (pull the air choke handle) if the generator is not warmed up.
5. Set the GASOLINE FUEL SWITCH to the "OFF" position.
6. Open the gas valve on the cylinder, making sure that no gas is leaking.
7. Set the engine start to the "ON" position.
8. Grasp the starter handle and slowly pull it until resistance is felt. Pull the starter cord to the full length with a sharp movement. The generator will start. If this is not the case, repeat this action. Slowly turn the manual starter by hand, do not release it abruptly. Open the air choke by pushing the air choke handle.



RECOMMENDATION! When using for the first time, fill the gas line with gas by setting multifunctional switch to position OFF and slowly pulling the starter handle to the full cord length 2 to 3 times.

TO START GENERATOR KS 3200i CO

1. Check oil level.
2. Check fuel level. Add unleaded fuel in the fuel tank if fuel level is insufficient.
3. Open fuel valve
4. Close the Choke
5. Set engine switch button to ON position.
6. Pull the manual starter until a slight resistance is felt, then pull it toward you relatively sharply. Slowly turn the manual starter by hand, do not release it abruptly.
6. Open the choke
7. Wait 1-2 minutes and connect appliances.

TO START LPG/GASOLINE GENERATOR KS 4000iEHS CO IN GASOLINE MODE:

1. Check oil level.
2. Check fuel level. Add unleaded fuel in the fuel tank if fuel level is insufficient.
3. Turn the Multifunctional engine switch to the "START" position (fig. 6). In this position the Choke is closed.
4. For manual start , pull the manual starter until a slight resistance is felt, then pull it toward you relatively sharply. Slowly turn the manual starter by hand, do not release it abruptly. For electric start, press the red button on the multifunctional engine switch (fig. 6).
6. After starting the engine, turn the Multifunctional engine switch to the "RUN" position (fig. 7).

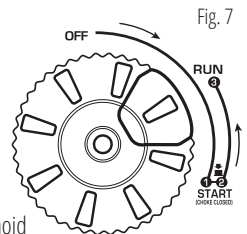
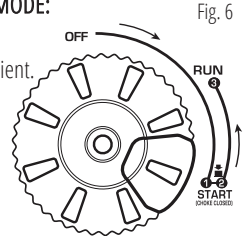
**TO START LPG/GASOLINE GENERATOR KS 4000iEHS CO IN LPG MODE:**

1. Check oil level.
2. The inverter generators KS 4000iEHS CO, has smart fuel switching system. In order to use LPG as fuel you need to connect a hose to the corresponding connector and open the valve on the gas cylinder. The solenoid valve will automatically shut off the gasoline supply from the gasoline tank.
3. Connect the LPG hose to the LPG input (connect hose end **A** to the LPG input, as shown in Fig. 5).
4. Connect the hose end with the reducer to the gas cylinder (connect hose end **B** to the gas cylinder, as shown in Fig. 5).
5. Open the gas valve on the cylinder, making sure that no gas is leaking.

6. Turn the Multifunctional engine switch to the "START" position (fig. 6).
7. For manual start, pull the manual starter until a slight resistance is felt, then pull it toward you relatively sharply. Slowly turn the manual starter by hand, do not release it abruptly. For electric start, press the red button on the multifunctional engine switch (fig. 6)
9. After starting the engine, turn the Multifunctional engine switch to the "RUN" position (fig. 7).

RECOMMENDATION! When using for the first time, fill the gas line with gas by setting multifunctional switch to position OFF and slowly pulling the starter handle to the full cord length 2 to 3 times.

TO START LPG/GASOLINE GENERATOR KS 6000iEHS CO IN GASOLINE MODE:

1. Check oil level.
2. Check fuel level. Add unleaded fuel in the fuel tank if fuel level is insufficient.
3. Turn switch to GASOLINE position (fig. 8).
4. Open the vent on the fuel cap to the "ON" position (fig. 3).
5. Press the button for electric start or pull the rope for manual start until a slight resistance is felt, then pull it toward you relatively sharply. Slowly turn the manual starter by hand, do not release it abruptly.
6. Turn switch back to RUN position (fig. 9).

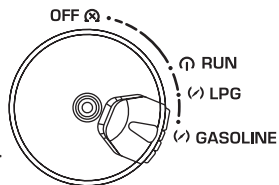

Fig. 8

TO START LPG/GASOLINE GENERATOR KS 6000iEHS CO IN LPG MODE:

1. Check oil level.
2. The inverter generator KS 6000iEHS CO has a smart fuel switching system. In order to use LPG as fuel you need to connect a hose to the corresponding connector and open the valve on the gas cylinder. The solenoid valve will automatically shut off the gasoline supply from the gasoline tank.
3. Connect the LPG hose to the LPG input. (Connect hose end **A** to the LPG input, as shown in Fig. 5).
4. Connect the hose end with the reducer to the gas cylinder (connect hose end **B** to the gas cylinder, as shown in Fig. 5).
5. Turn switch to LPG position (fig. 10).
6. Open the gas valve on the cylinder, making sure that no gas is leaking.
7. Press the button for electric start or pull the rope for manual start until a slight resistance is felt, then pull it toward you relatively sharply. Slowly turn the manual starter by hand, do not release it abruptly.
8. Turn switch back to RUN position (fig. 9).

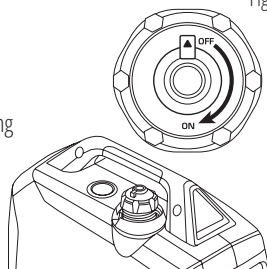

Fig. 3

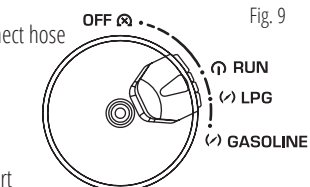

Fig. 9

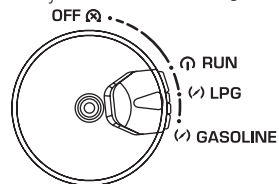

Fig. 10

RECOMMENDATION! When using for the first time, fill the gas line with gas by setting multifunctional switch to position OFF and slowly pulling the starter handle to the full cord length 2 to 3 times.



IMPORTANT!



Useful tip: to ensure long-term operation of the generator engine, it is important to observe the following tips:

- Before connecting the load, allow the engine to run for 1-2 minutes to warm it up.
- When disconnecting the load after lengthy operation, do not turn off the generator. Allow the generator to run idle for 1-2 minutes so that it cools down.



ATTENTION – DANGER!



Do not connect two or more devices at a time. The start-up of many devices requires high power. Devices should be connected one at a time according to their power rating. Do not connect any power consumers within the first 2 minutes after the generator has been started.



IMPORTANT!



Disconnect the load from the generator before changing fuel. The ECO MODE switch must be in the “OFF” position.

For model KS 2000iHS CO: It is recommended to stop the generator before switching from gasoline to LPG! Gasoline remains in the carburetor making it difficult to start the engine on LPG. Let the generator run out of gasoline until it stops. To do this, close the fuel valve with the generator running and wait until the generator stops completely. Then start the generator on LPG. You can also drain the remaining gasoline from the carburetor before starting the generator on LPG.

To drain gasoline from the carburetor, turn off the fuel valve and wait until the generator has cooled down sufficiently. For open frame models, place a drip pan under the carburetor and loosen the drain screw on the carburetor (Fig. 11). Make sure that no fuel leaks onto the generator. Tighten up the screw again. Start the generator on LPG according to the instructions mentioned above

Fig. 11

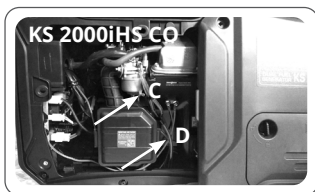

For all modifications of models KS 2000i, loosen the 4 screws on the side panel. Loosen drain screw **C** on the carburetor and let the remaining fuel drain through pipe **D** into the dedicated drip pan. Avoid gasoline leaks. Tighten up the screw. Install back the generator housing cover. Start the generator on LPG.



IMPORTANT!



Place the container with gas only vertically, according to the instruction manual for gas cylinders. The horizontal placement of gas cylinders leads to hybrid generator gearbox failure.

For KS 4000iEHS CO and KS 6000iEHS CO fuel can be changed without stopping the generator. When switching from gasoline to LPG operation, the generator may be unstable during the first 2-3 minutes and the low voltage protection may trip. If the red indicator (overload indicator) lights up in 2-3 minutes after running the generator on LPG when it is running stable, press the AC Reset BUTTON on a panel of generator to restore voltage supply.

If during running on gasoline, you need to switch to LPG supply, directly connect the LPG pipe, turn on the LPG supply, and press the LPG RESET on the control panel to switch to LPG.

If during usage of LPG, you need to switch to gasoline, you only need to disconnect the LPG supply, generator will automatically switch to gasoline operation, without other operations.

For models with electric start, check if the battery is charged. If necessary, recharge the battery with a dedicated charger for lithium-ion batteries or start the generator with a manual start and allow it to run idle while it is recharging.

FUNCTIONAL DESCRIPTION OF INVERTER GENERATORS

12

It is forbidden to start the generator with the ECO Mode ON. ECO Mode should be turned on only after starting the generator and only with a low load. Failure to comply with this requirement may result in generator failure and void warranty repair.

HOW TO USE ECO MODE:

1. Start the engine.
2. Set the ECO mode switch to "ON".
3. Plug the device into an AC outlet.
4. Make sure the AC indicator light is on.
5. Turn on the electrical device.

**IMPORTANT!**

The Eco mode switch must be set to "OFF" to increase engine speed to nominal. When connecting multiple power consumers to the generator, be sure to first connect the one with the highest starting current, and the device with the lowest starting current should be connected last.

"ON" MODE

When the Eco mode switch is in the "ON" position, the control unit monitors the engine speed, reducing it commensurate with the connected load. If the engine speed is not enough to generate electricity to provide the load, the control unit will automatically increase the engine speed.

As a result, fuel consumption is optimized, and noise levels are reduced.

"OFF" MODE

The Eco mode switch must be set back to "OFF" when using electrical devices requiring a high starting current, such as a compressor or submersible pump.

**IMPORTANT!**

The Eco mode switch must be set back to "OFF" when using electrical devices requiring a high starting current, such as a compressor or submersible pump.

PARALLEL FUNCTION

Generators KS 2000iS CO, KS 2000iHS CO, KS 4000iEHS CO are parallel ready. The total output power of the generators can be increased by connecting two inverter generators together using the Parallel Unit KS PU1-US from Könnér & Söhnen®. Parallel connection of two generators ensures total rated output power of these generators. When the generators are connected in parallel, the power loss is 0.2 kW of the total rated power that can be obtained (suitable for all models of inverter generators from Könnér & Söhnen®).

DISCONNECT ALL DEVICES BEFORE STOPPING THE GENERATOR!

Do not stop the generator with the devices turned on. This may disable the generator or devices connected to it!

TO STOP THE ENGINE, PROCEED AS FOLLOWS

1. Turn off all devices.
2. Allow the generator to run idle for approx. 1-2 minutes.
3. Turn the engine switch to the "OFF" position (for KS 2000iHS CO turn the fuel switch to the OFF position, for KS 3200i CO - close the fuel valve).
4. Close the gas valve (for dual fuel models).
5. Unplug the devices.
6. After the generator stops, allow it to cool down and close the air vent on the fuel cap (set to OFF, as shown in Fig. 12, when switching off gasoline operation for KS 2000iS CO, KS 2000iHS CO, KS 6000iES CO and KS 6000iEHS CO models).

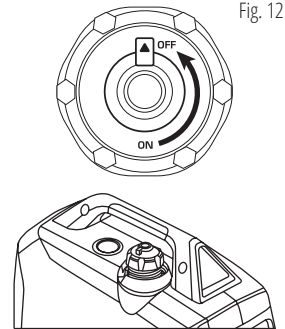

Fig. 12

CHARGING AN EXTERNAL 12 V BATTERY

1. Start the engine.
2. Connect the red wire to the positive (+) terminal of the battery.
3. Connect the black wire to the negative (-) terminal of the battery.

4. Connect the wire to a 12V/8A DC socket on the control panel of the generator.
5. To start charging the battery, set ECON to "OFF".
6. Turn the 12 V DC circuit breaker to the "ON" position.



IMPORTANT!



Inverter generators from Könnér & Söhnen are equipped with lithium batteries with an operating voltage similar to conventional lead-acid batteries. When the generator is running, the battery is charged automatically. If it is necessary to charge the battery with an external device, we recommend using the KS-B2A charger or the charger for charging lead-acid motorcycle batteries with a nominal voltage of 12V with a charge current of not more than 2A.



IMPORTANT!



- Make sure the Eco mode is off while the battery is being charged.
- Be sure to connect the charger's red wire to the plus (+) terminal of the battery and the black wire to the minus (-) terminal of the battery. Do not swap the terminals.
- Connect the charger to the battery terminals securely so that they are not disconnected due to motor vibrations or other actions.
- The 12 V socket can only be used as a backup source for recharging batteries and shall not be deemed as a full-featured battery charger.
- The DC protector turns off automatically if the current is higher than the rated current while the battery is being charged. To restore battery charging, turn on the DC circuit breaker by pressing the "ON" button.



ATTENTION - DANGER!



Never smoke or interrupt battery connections to the generator while the battery is being charged.

MAINTENANCE

10

This manual compliance! You can find a list of service center addresses on the website of exclusive importer: www.konner-sohnen.com/us

TECHNICAL MAINTENANCE WORKS

Unit	At each start	First month or 20 operating hours	Every 3 months or 50 operating hours	Every 6 months or 100 operating hours	Every year or 300 operating hours
Motor oil	LEVEL CHECK				
		REPLACEMENT	REPLACEMENT		
Air filter	CHECK /CLEANING	CHECK /CLEANING	CHECK /CLEANING		
				REPLACEMENT	
Spark plug		CLEANING	CLEANING		
				REPLACEMENT	
Fuel tank	LEVEL CHECK				
					CLEANING
Fuel filter		CHECK (CLEAN OUT)	CHECK (CLEAN OUT)		

- If the generator often operates at high temperature or high load, the oil should be replaced every 25 operating hours.
- If the engine often runs in dusty or other harsh conditions, clean the air filter every 10 operating hours.
- If you missed the maintenance time, perform it as soon as possible to save the generator engine.



IMPORTANT!



The manufacturer shall not be liable for any damage caused by failure to perform maintenance work.

RECOMMENDED OILS

13

The SAE viscosity grade shown in the following table. Use oils designed for four-stroke cycle vehicle engines SAE10W-30. Motor oils with other viscosity levels may be used only if the average air temperature in your region does not exceed the limits of the temperature range, specified in the table.

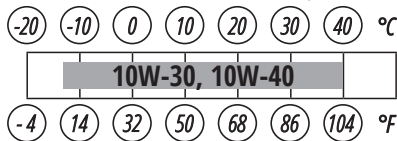

Upon oil level decrease it is necessary to add the required quantity in order to provide the correct generator operation. It is necessary to check the oil levels according to technical maintenance schedule. Further details can be found in the full version of the manual on our website.

TO DRAIN ENGINE OIL, PERFORM THE FOLLOWING ACTIONS (SEE THE SAMPLE PICTURES FOR DRAINING OIL FOR MODEL KS 4000IEHS CO):

1. Please drain the oil while the engine is warm. This provides a quick and complete oil drain.
2. Wear protective gloves to avoid getting oil on the skin.
3. Remove the cover of generator (fig. 13).
4. Place a drain oil holding tank under the engine (fig. 14).
5. Turn the drain cap, located in the engine under the oil-depth gage cap, by means of spanner (fig. 15).
6. Wait till the oil drains.
7. Replace the drain cap and tighten it well.
8. Close the maintenance cover (fig. 13).

Fig. 13

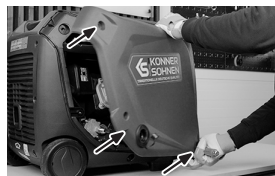

Fig. 14

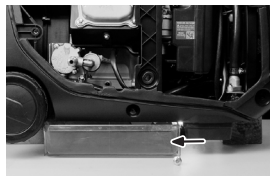

Fig. 15



SPARK PLUGS TECHNICAL MAINTENANCE

14

Spark plug must be intact, without soot deposits and to have a correct gap.

SPARK PLUG VERIFICATION:

1. Remove the cap from the spark plug.
2. Remove the spark plug by means of a corresponding spanner.
3. Examine the spark plug. If is shattered – it is necessary to replace it.

Recommended replacement spark plugs – F7TC.

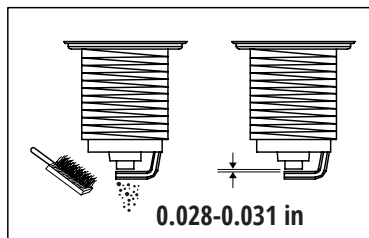

4. The gap should be 0.7-0.8 mm (0.028-0.031 in).
5. In case of repeated use, the spark plug must be cleaned by means of a metal brush.
After that – set the correct gap.

AIR FILTER TECHNICAL MAINTENANCE

15

Air filter cleaning is to be performed every 50 hours of the generator operation (every 10 hours in unusually dusty conditions).

CLEANING THE FILTER:

1. Open the clips on the upper cap of the air filter.
2. Remove the sponge filtering element.
3. Remove all dirt deposits inside the hollow case of the air filter.
4. Thoroughly wash the filtering element in warm soapy water.
5. Dry the sponge filter.
6. Dry filtering element is to be moistened by motor oil and excess oil is to be squeezed out.

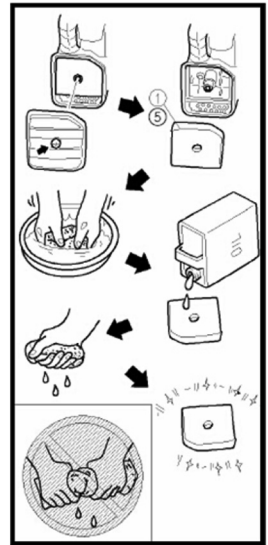

DAMPER AND FLAME ARRESTER MAINTENANCE

16

The engine and damper will get very hot after the generator has been started. Do not touch the engine or damper with any part of your body or clothing during inspection or repair until they have cooled down.

Remove the screws and then pull the protective cover towards you (fig. 15). Loosen the bolts and remove the cover, screen, and flame arrester of the damper. Descal the screen and flame arrester of the damper with a wire brush. Inspect the screen and flame arrester of the damper. Replace them if they are damaged. Replace the flame arrester. Replace the screen and cover of the damper. Replace the cover and tighten the screws.



IMPORTANT!



Match the protrusion of the flame arrester to the hole in the pipe damper.

Fig. 15

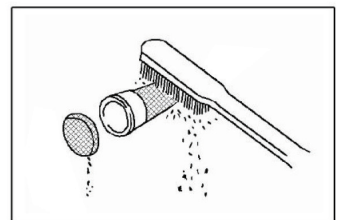
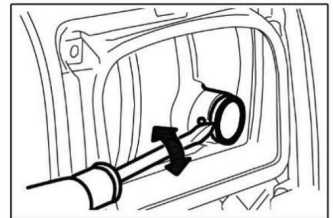

FUEL FILTER

17



IMPORTANT!



Never use gasoline while smoking or in the immediate vicinity of an open flame.

1. Remove the fuel tank cap and fuel filter.
2. Clean the filter with gasoline.
3. Wipe the filter and replace it.
4. Replace the fuel tank cap.

Make sure that the fuel tank cap is tight.

BATTERY USE

18

The generator battery is not subject to service. Low temperatures may lower the capacity of the lithium-ion battery and may cause an unstable generator to start. Battery warranted – six months from the date of purchase of the generator.

STORAGE

19



IMPORTANT!



DO NOT store generator with gasoline!



IMPORTANT!



The generator must be stored and transported with a closed vent at all times!

For long-term storage of the generator - it is necessary to drain the gasoline from the fuel tank and carburetor. DO NOT store generator with gasoline! Observe the permitted storage periods for each type of gasoline! The storage room has to be dry and free from dust deposits. The storage room also has to be locked away from children and animals. It is recommended to store and use the generator at temperatures of – 4 °F to +104 °F. Avoid direct sunlight, rain on the generator. When using and storing hybrid generator, gas tank should be kept indoors at temperatures below +50 °F. If the temperature is lower, gas will evaporate.

BATTERY AND GENERATOR DISPOSAL

20

To prevent environmental damage generator and battery should be separated from ordinary waste. Please recycle them in the safest way, passing them to special place for disposal.

Typical failures	Possible reason	Solution
Engine does not start	Engine starting switch set to OFF position	Set the engine starting switch to ON
	Fuel valve set to off position	Turn the valve to ON position
	Air flap is opened	Shut the air flap
	No fuel	Add fuel
	Low-quality or dirty fuel is in engine	Change the fuel
	Sparking plug smoked or corrupted distance between contacts is not nominal	Clean or replace the plug; Set proper distance between contacts
Low engine power / heavy starting	Dirt in fuel tank	Clean the fuel tank
	Dirt in the air filter	Clean the air filter
	Water in a fuel tank/ carburetor; carburetor is jammed	Empty the fuel tank, carburetor
	Distance between contacts of a sparking plug is not nominal	Set proper distance between contacts
Engine overheated	Cooling fins are dirty	Clean the cooling fins
	Air filter is dirty	Clean the air filter
No voltage while working engine	Circuit breaker is active	Turn on the circuit breaker
	Connected cables are corrupted	Check the cables, if using extension cord, change it
	Plugged device failure	Try to connect other devices
Connected devices are not working while generator is running	Generator is overloaded	Unplug some devices to reduce load
	Short circuit occurred in one of the devices connected	Unplug that device to restore the stability of a system
	Air filter is dirty	Clean the air filter
	Repetitions of an engine are lower than nominal	Contact the service center

Device	Average power usage, W
Iron	500-1100
Hair dryer	450-1200
Coffee machine	800-1500
Electric cooking stove	800-1800
Toaster	600-1500
Air heater	1000-2000
Vacuum cleaner	400-1000
Radio	50-250
BBQ Grill electric device	1200-2300
Oven	1000-2000
Refrigerator	100-150
TV set	100-400
Hammer drill	600-1400
Drill	400-800
Freezer	100-400
Grinding machine	300-1100
Circular saw	750-1600
Angle grinder	650-2200
Electric jigsaw	250-700
Electric planer	400-1000
Compressor	750-3000
Water pump	750-3900
Electric sawing machine	1800-4000
Electric lawn	750-3000
Electric powered engines	550-5000
Electric fan	750-1700
High pressure machine	2000-4000
Air conditioner	1000-5000

CIRCUIT DIAGRAM FOR KS 2000i CO

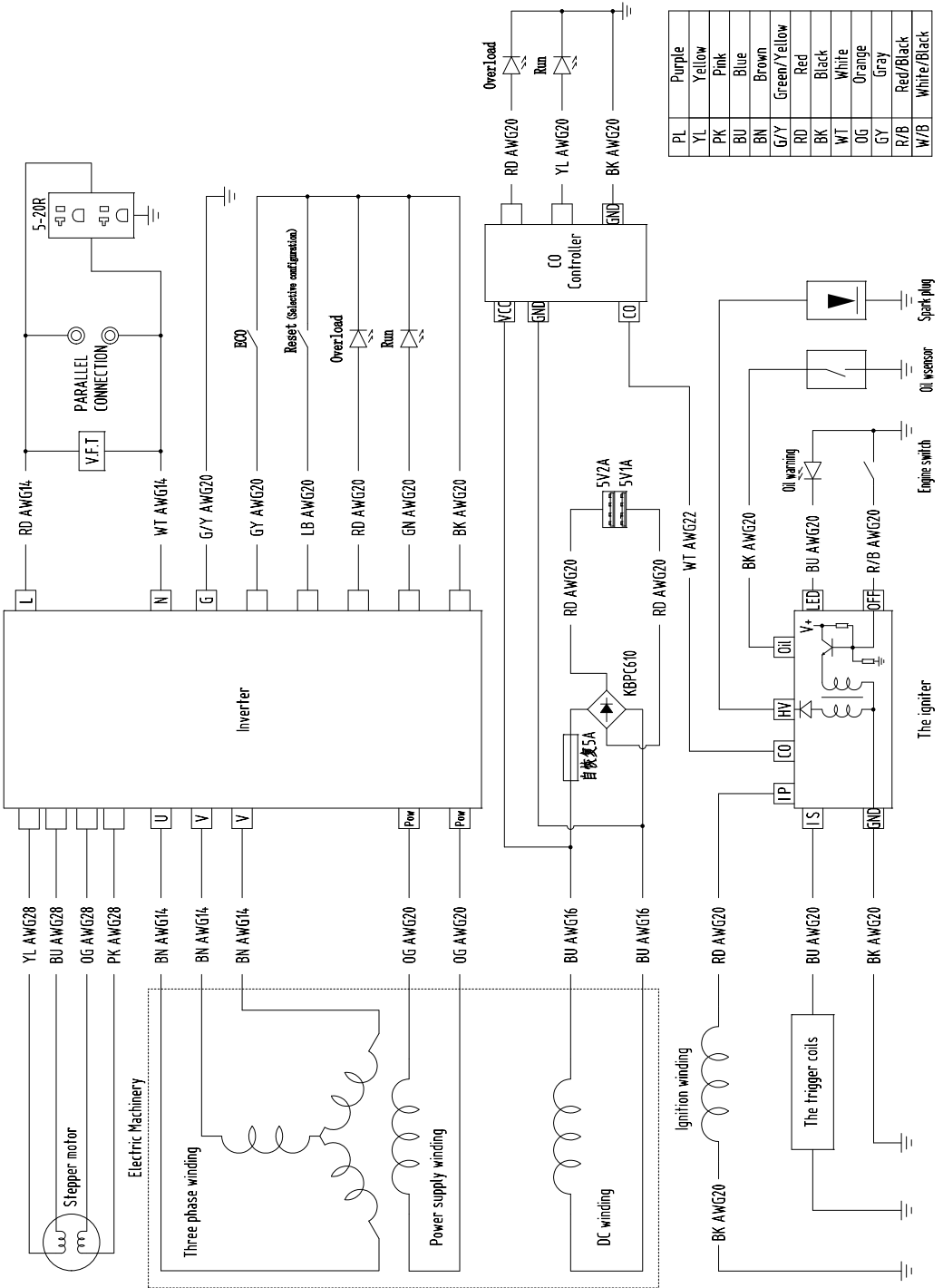

CIRCUIT DIAGRAM FOR KS 2000iHS CO

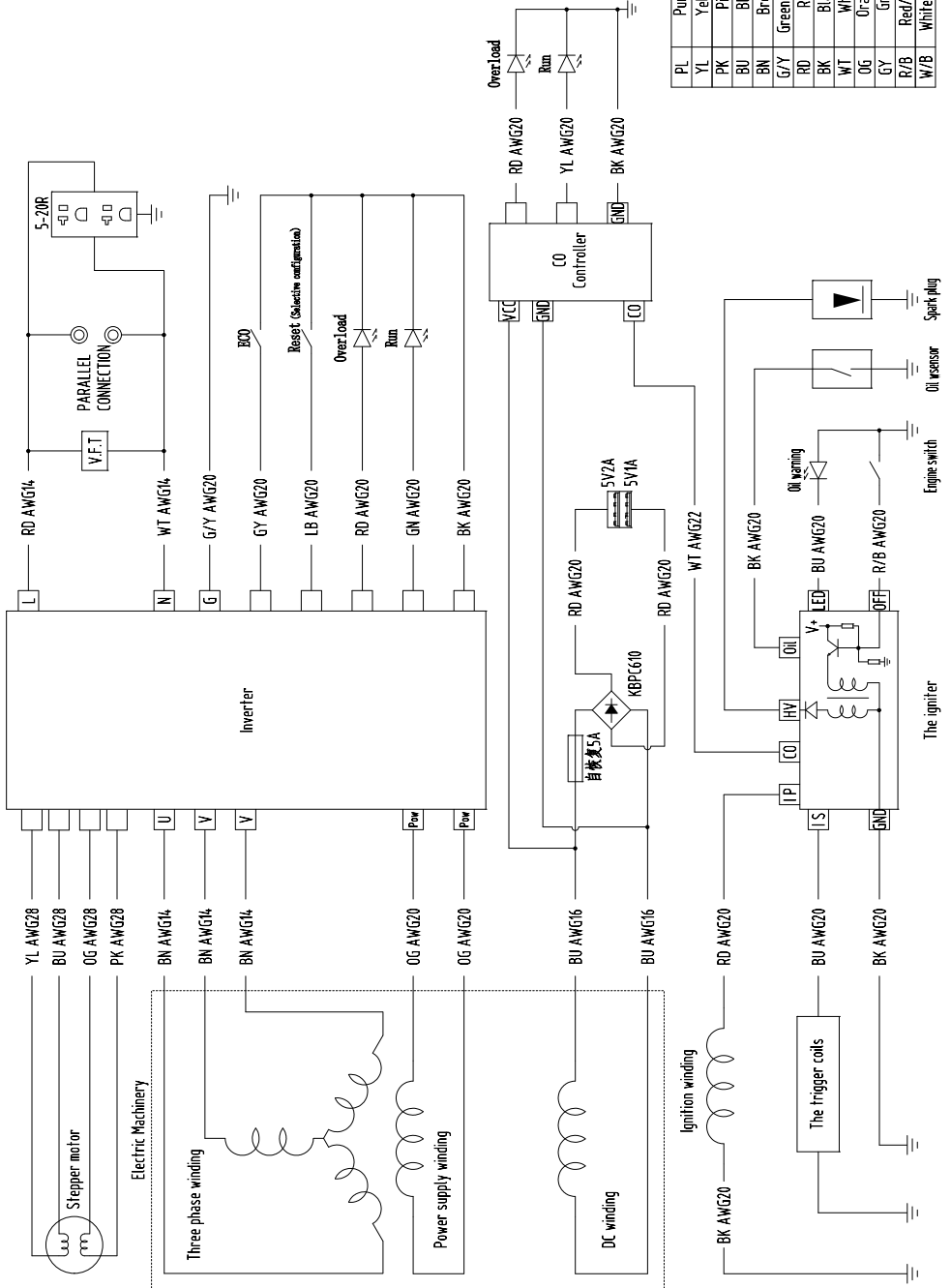

PL	Purple
YL	Yellow
PK	Pink
BU	Blue
BN	Brown
G/Y	Green/Yellow
RD	Red
BK	Black
WT	White
OG	Orange
GY	Grey
R/B	Red/Black
W/B	White/Black

CIRCUIT DIAGRAM FOR KS 3200i CO

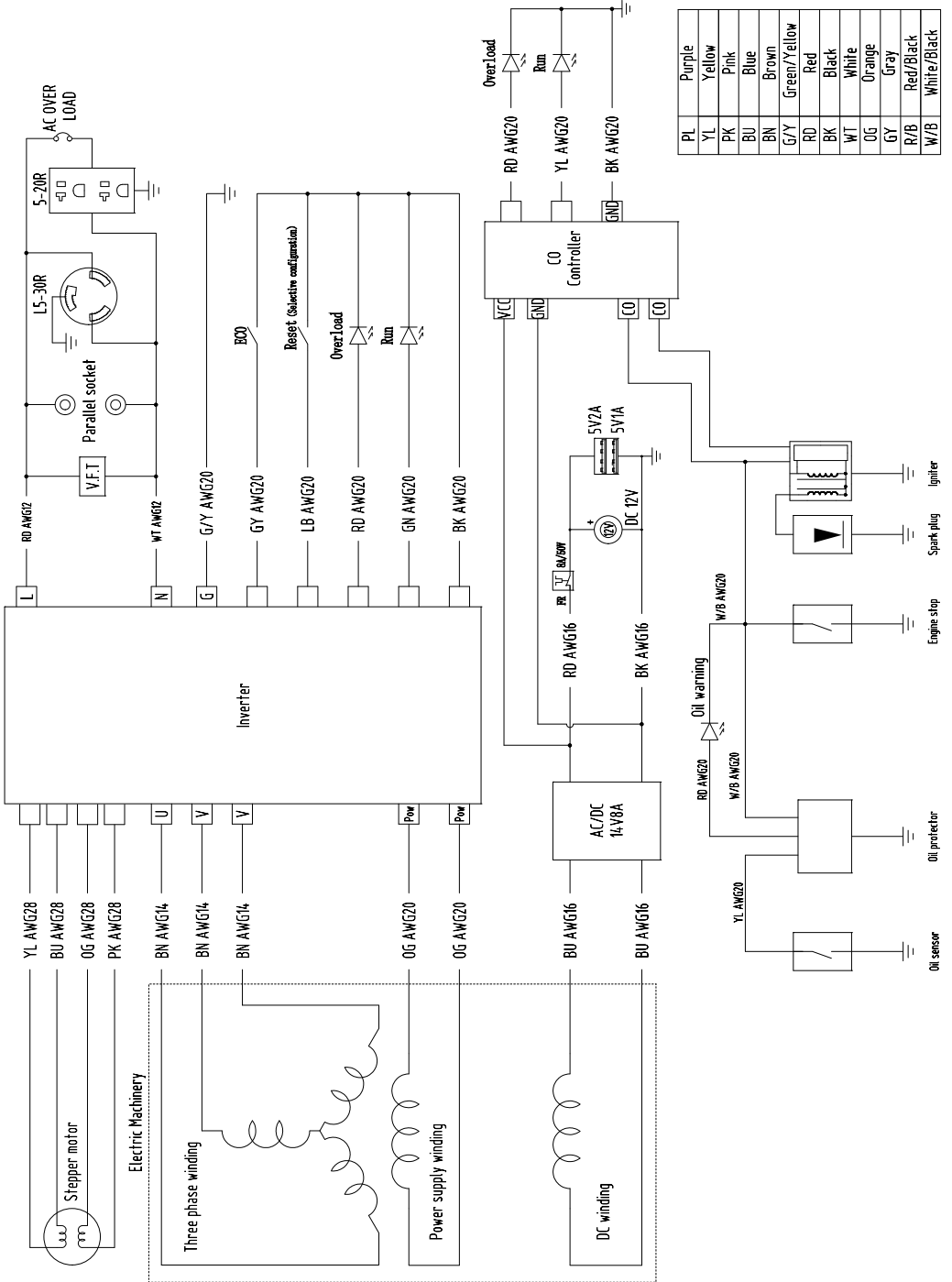

CIRCUIT DIAGRAM FOR KS 4000iHS CO

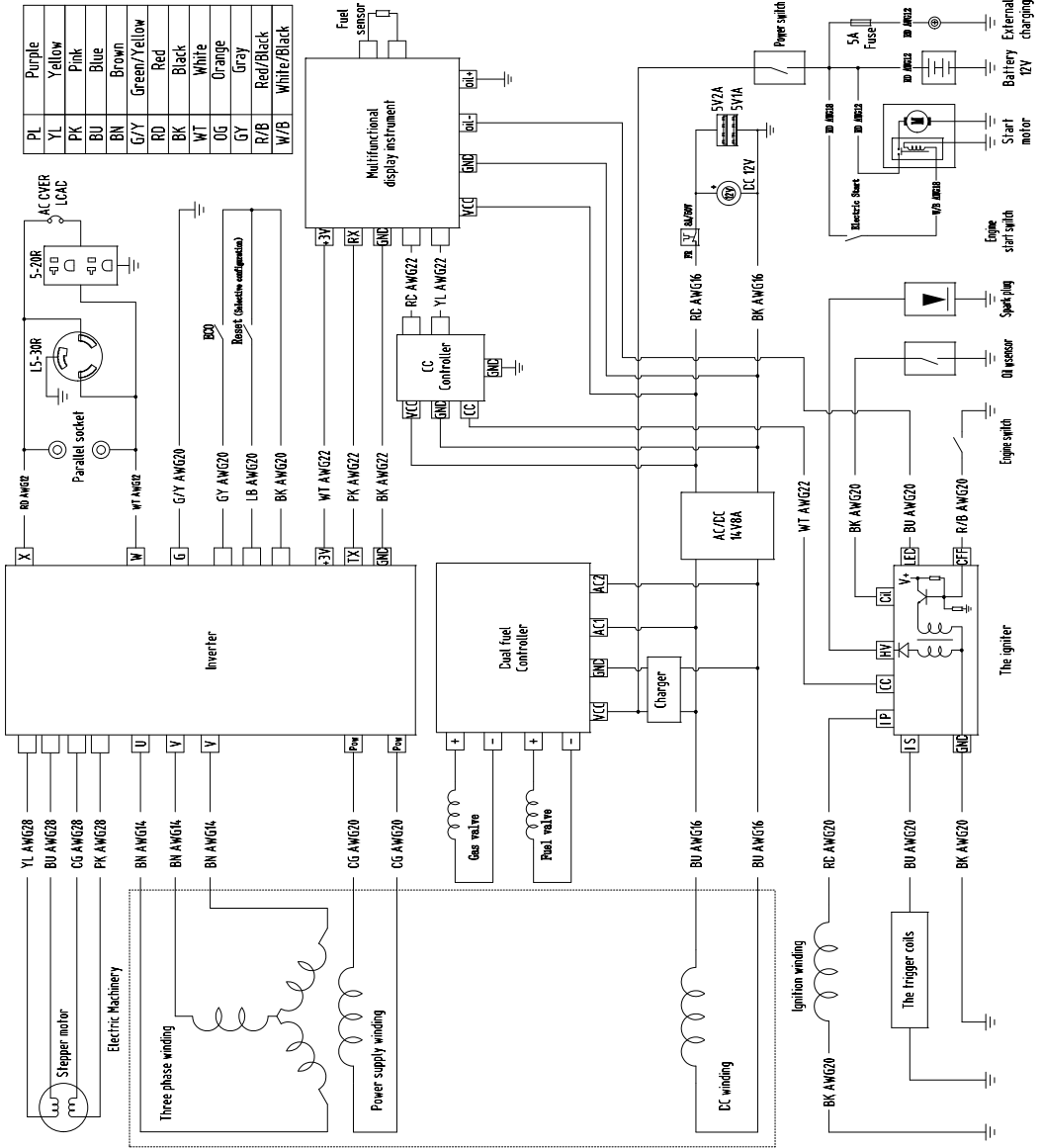

CIRCUIT DIAGRAM FOR KS 6000iE CO

Purple	PL
Yellow	YL
Pink	PK
Blue	BU
Brown	BN
Green/Yellow	G/Y
Red	RD
Black	BK
White	WT
Orange	OG
Gray	GY
Red/Black	R/B
White/Black	W/B

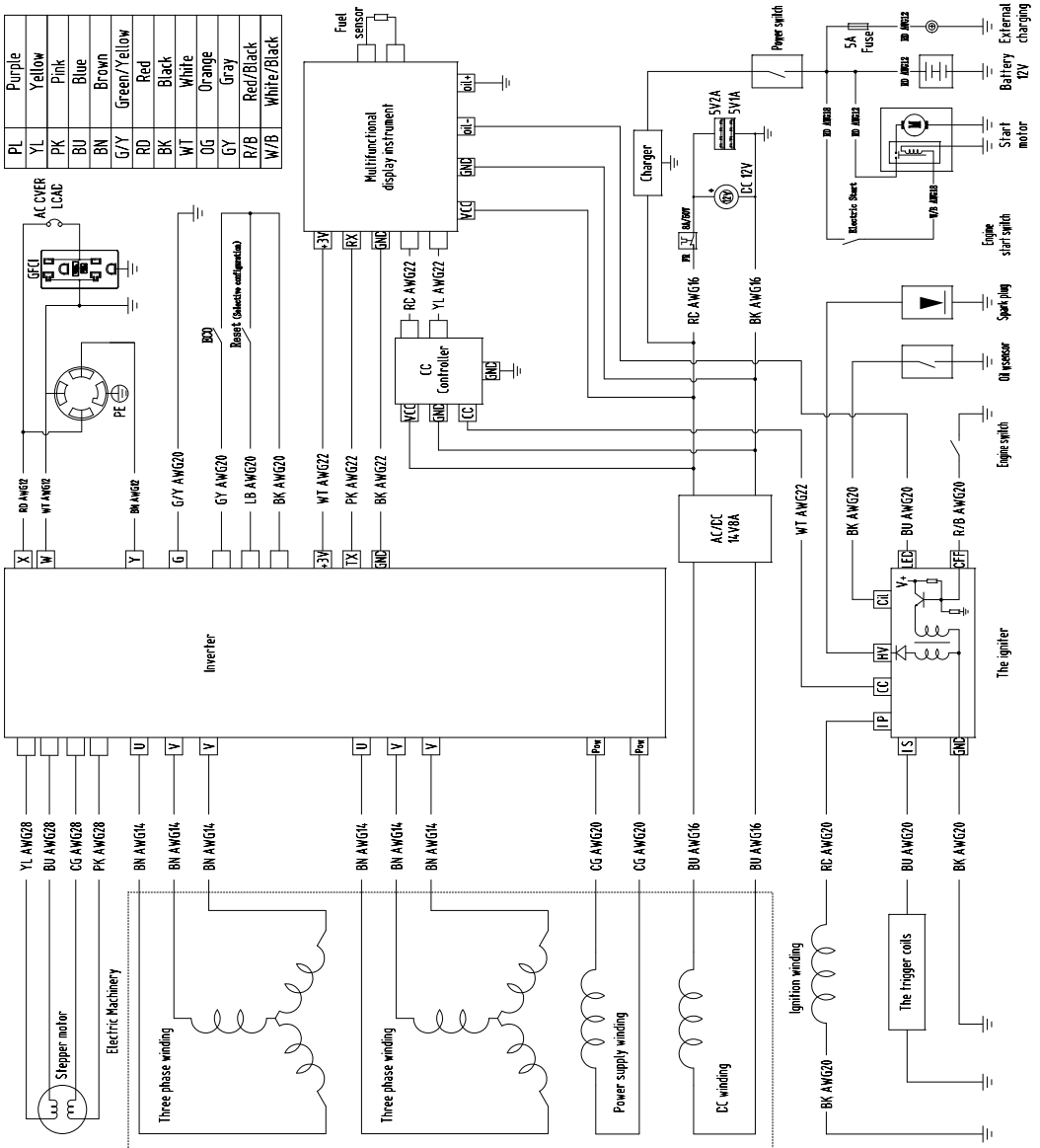

CIRCUIT DIAGRAM FOR KS 6000iHS CO

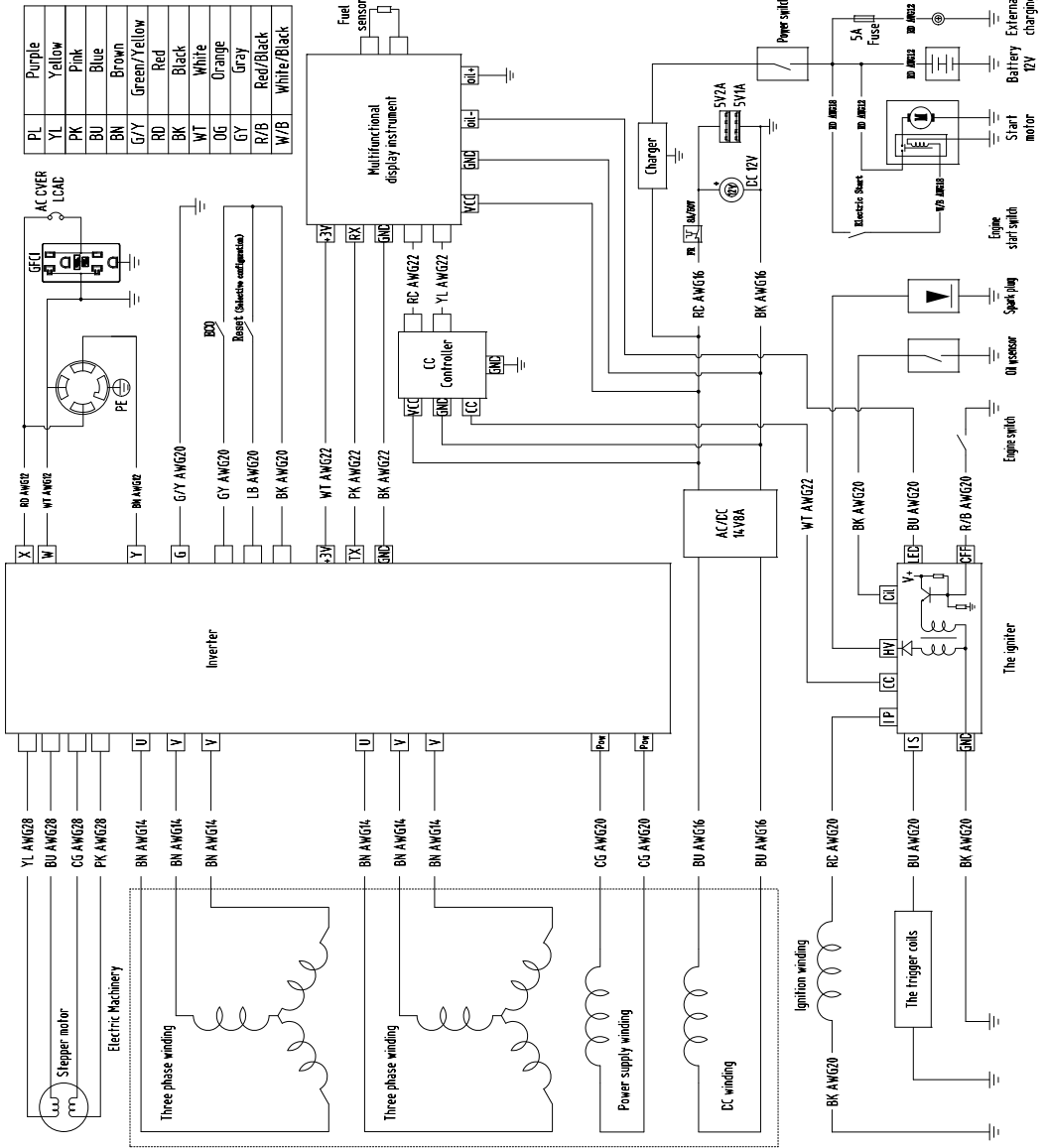

CONTACTS

United States of America:
KS Energy Solutions Inc.
Balcones Drive STE 100 Austin,
TX 78731

Authorized Warranty Service
support.us@dimaxgroup.com
www.konner-sohnen.com/us