

# AUXXLIFT 2400 / 2600

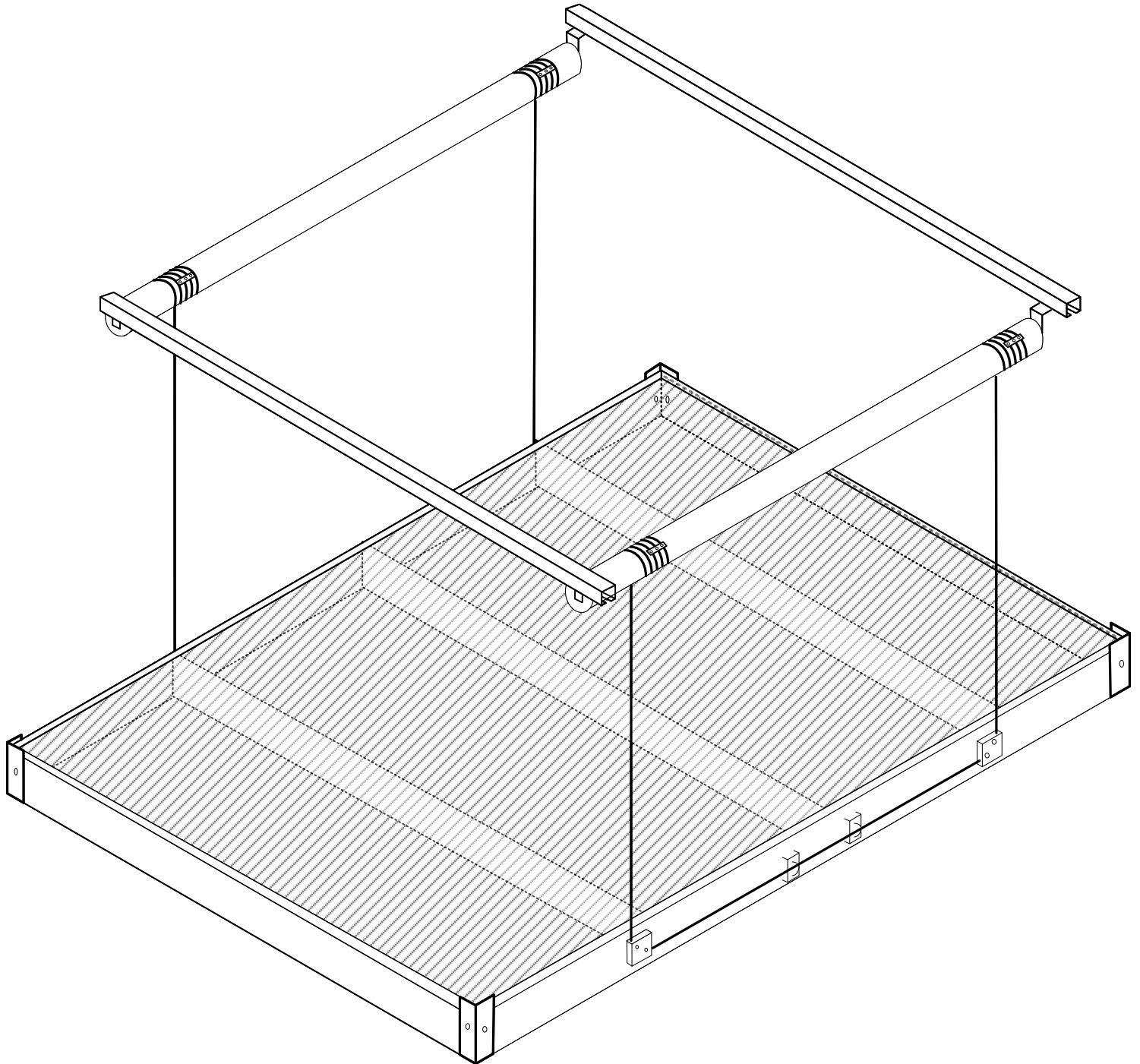

All rights reserved  
US Patent  
Release 07/2021/SW



Design and Quality  
AUXXLIFT of the USA

# Before YOU start

1. Have you read through the instructions?
2. Do you have all the recommended tools?
3. Do you have somebody assisting you?
4. Have you allocated enough time?

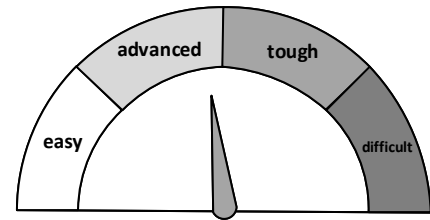

For a professional it takes about 3 hours to install.

## ***What is most important is to follow the instructions***

and read everything carefully before you start.

5. You need a good, stable ladder.
6. Don't use an impact driver.
7. Clean the area before you start.
8. Wear safety glasses!
9. Keep work area clear!

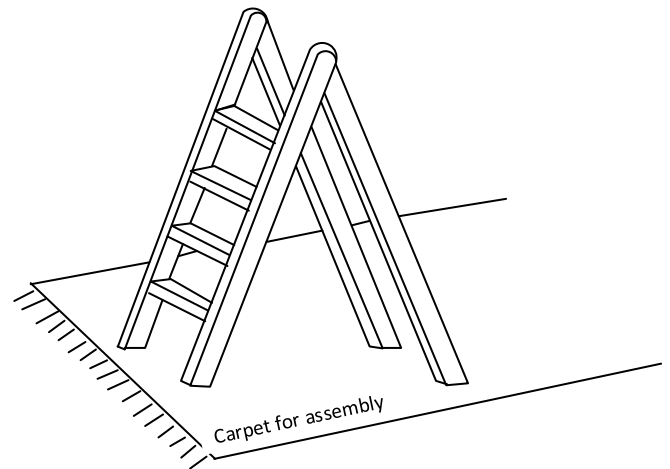

Check measurements during construction.

Make sure that nothing is in the way e.g. windows, doors etc.

10. Does your garage ceiling have or has had termites?
11. Are the joists strong and big enough? (2" x 4" at least)
12. Mounting to a concrete ceiling requires anchors!
13. Has your home been built according to valid standards and guidelines?
14. If you have doubts about the ceiling construction, please ask a specialist!

If you have any problems understanding the instructions or you feel uncomfortable handling the installation, please ask a handyman or work with a contractor. Call/ write us if you need help or have concerns or questions.



[www.auxx-lift.com](http://www.auxx-lift.com)

Help phone: PST 10 am -3 pm 1 805 862 8271

# RECOMMENDED TOOLS

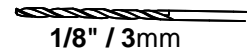
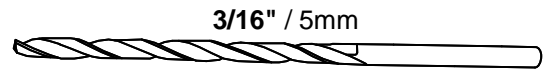
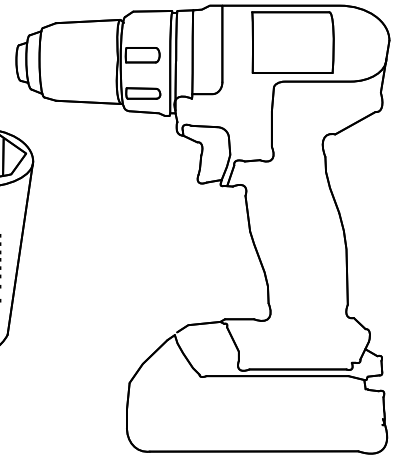
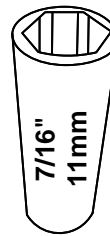
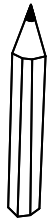
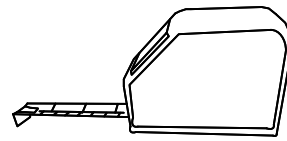
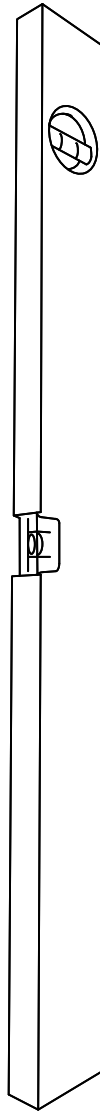
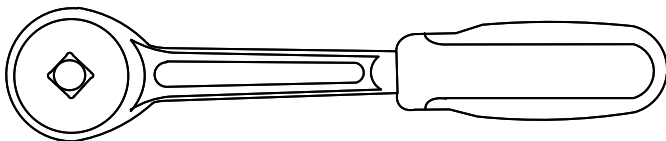
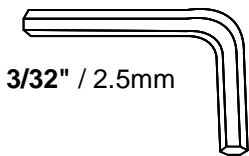
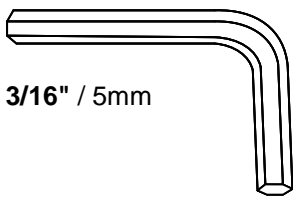
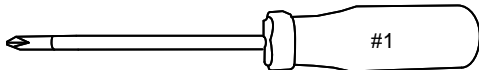
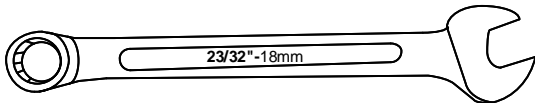
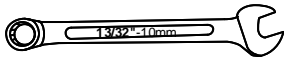
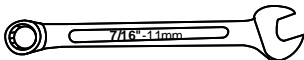
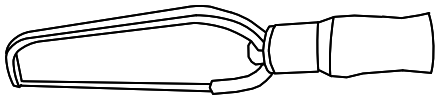
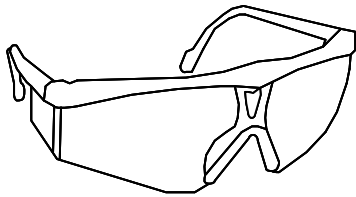

## Nice to have

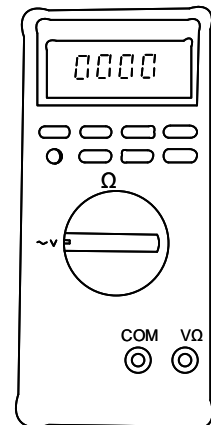
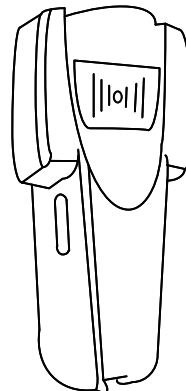
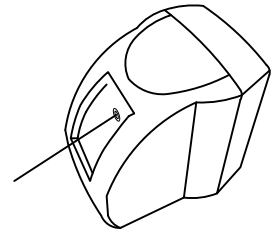

# LIST OF PARTS

\*Bold numbers are for 600lbs version

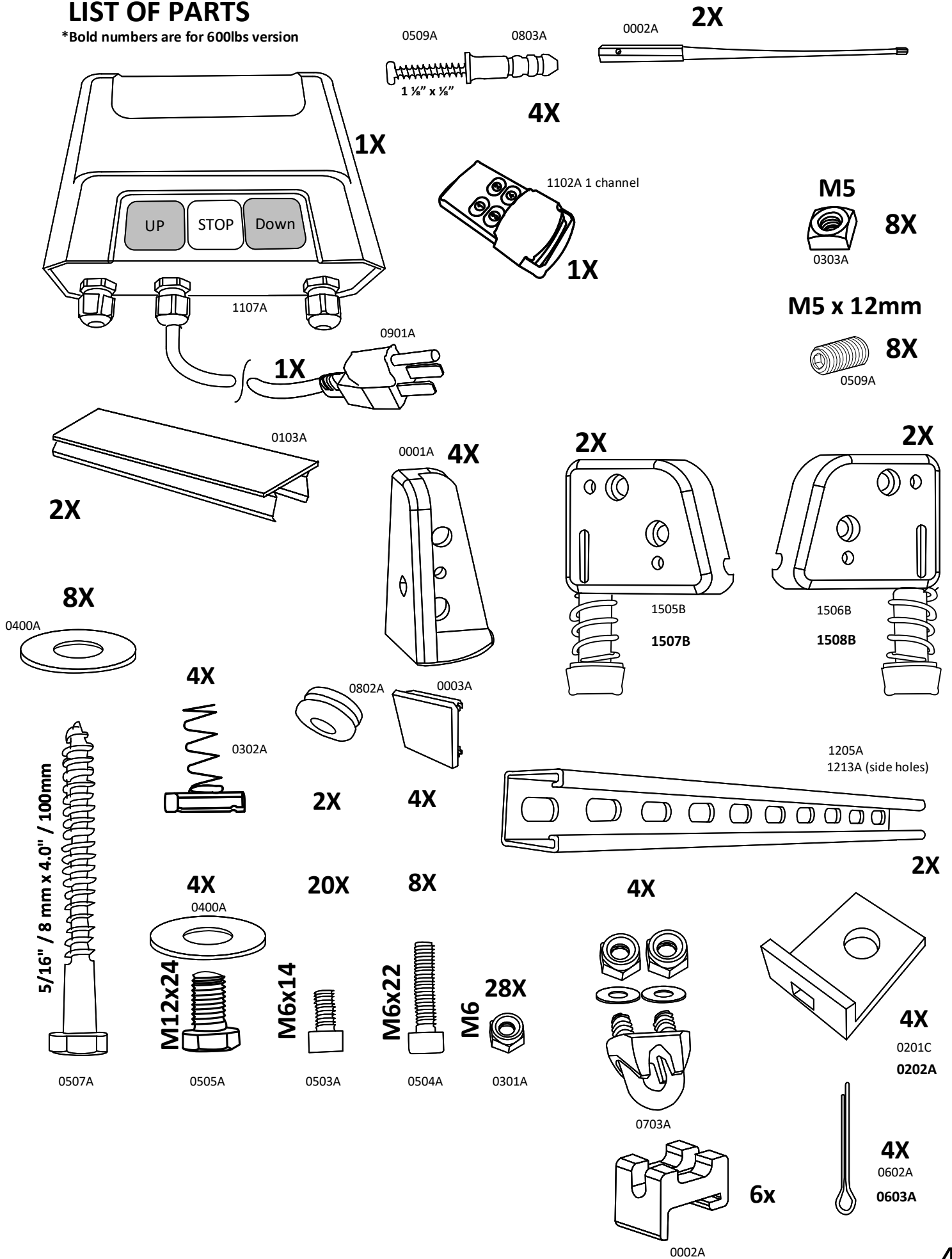

# LIST OF PARTS

\*Bold numbers are for 600lbs version

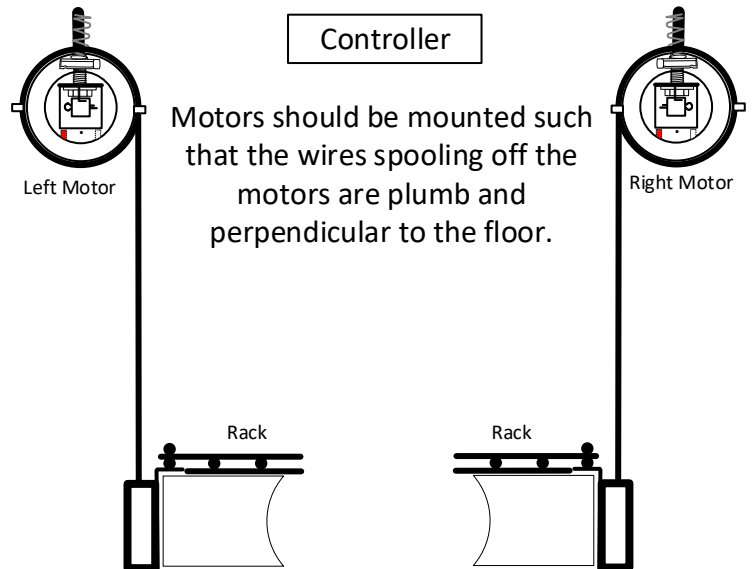
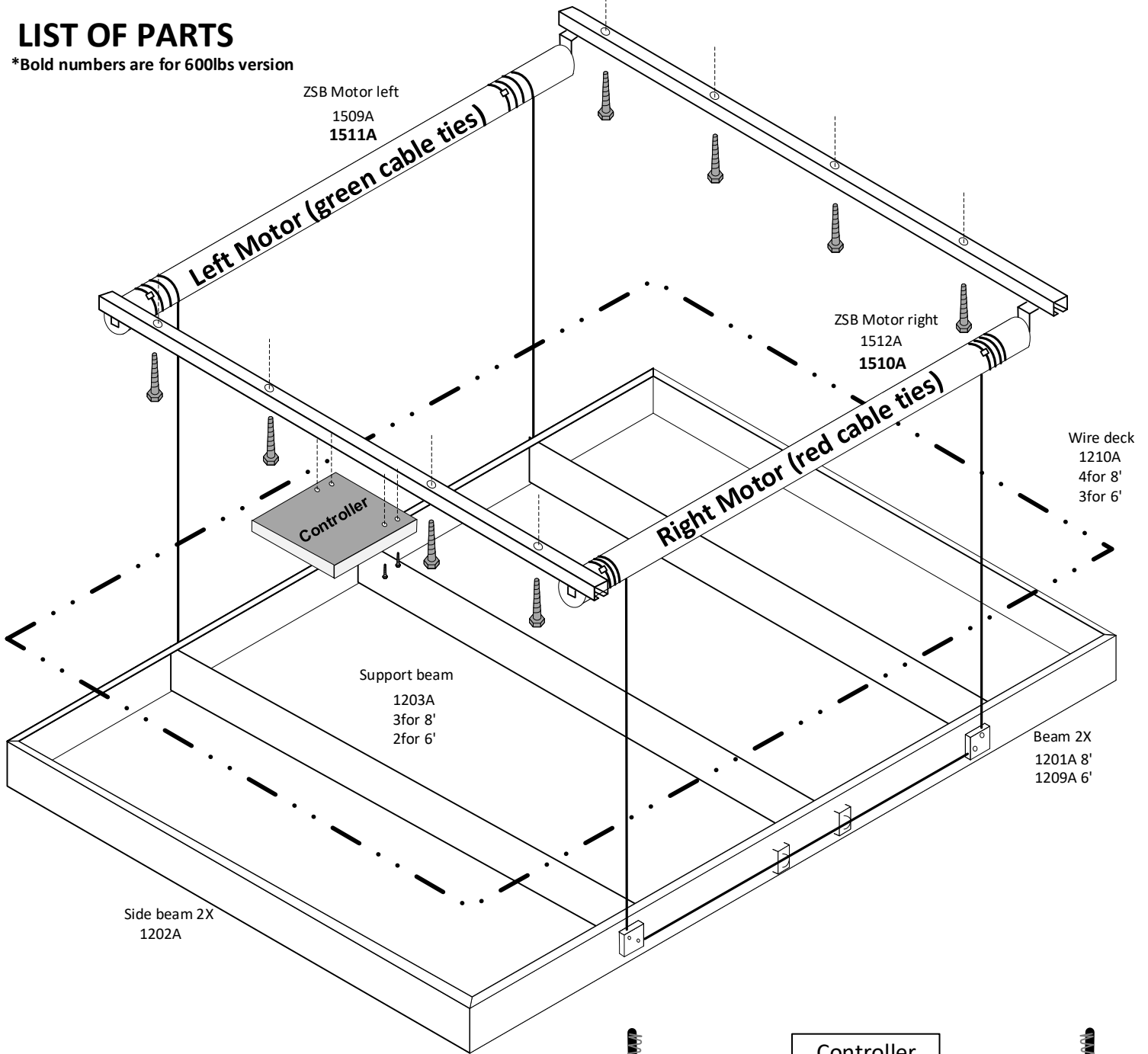

**i** Information

**t** Trouble shooting



Option 1

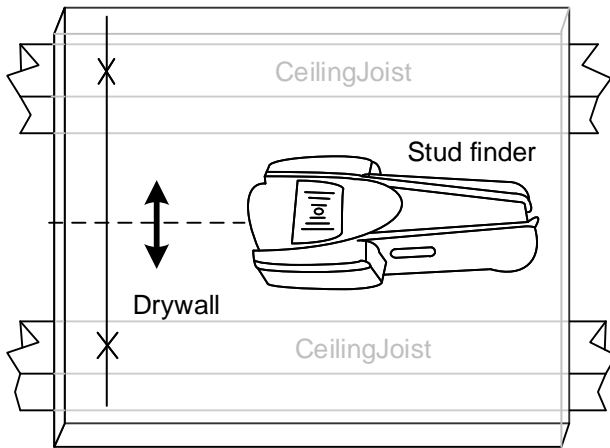

Option 2

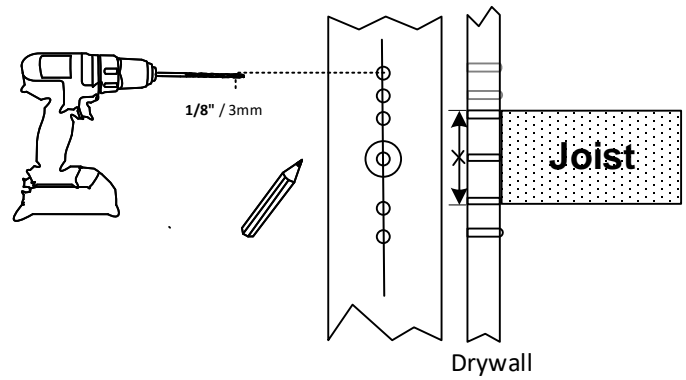

Rail overhang on joists should be less than 12" / 30cm

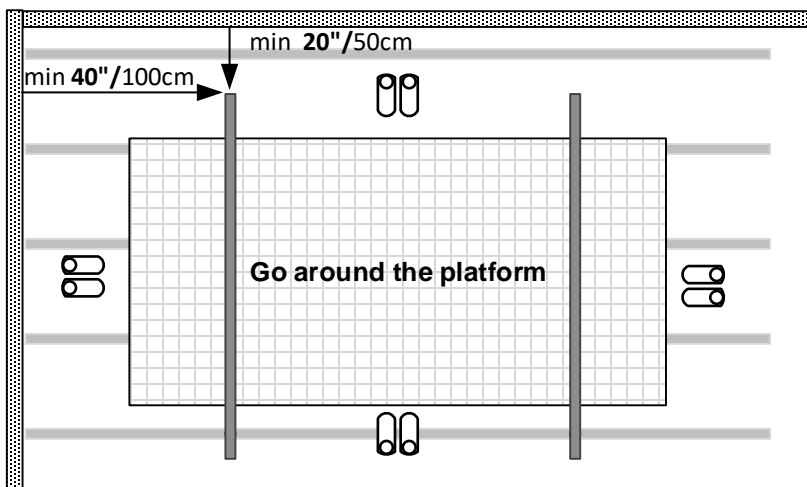
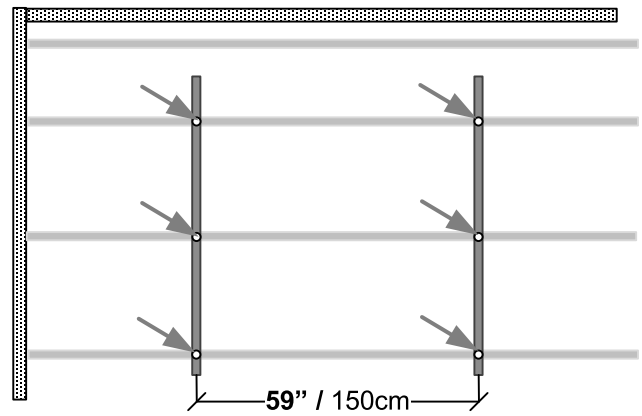
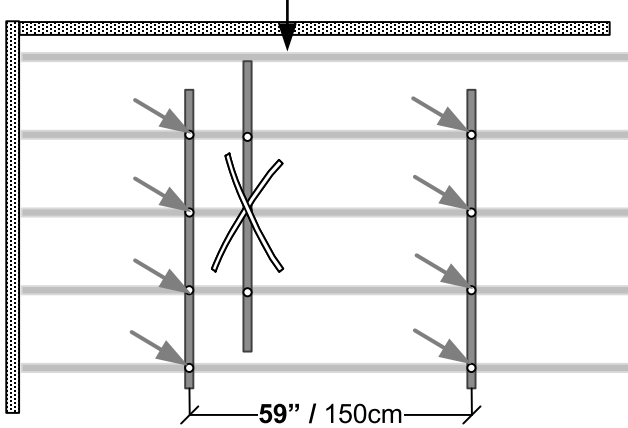

**!** If you have doubts about the ceiling construction, please ask a specialist!

*For installations where joists are rotated 90°, please visit Page 11  
Minimum Required Area, please visit Page 10*



# Do's and Don'ts

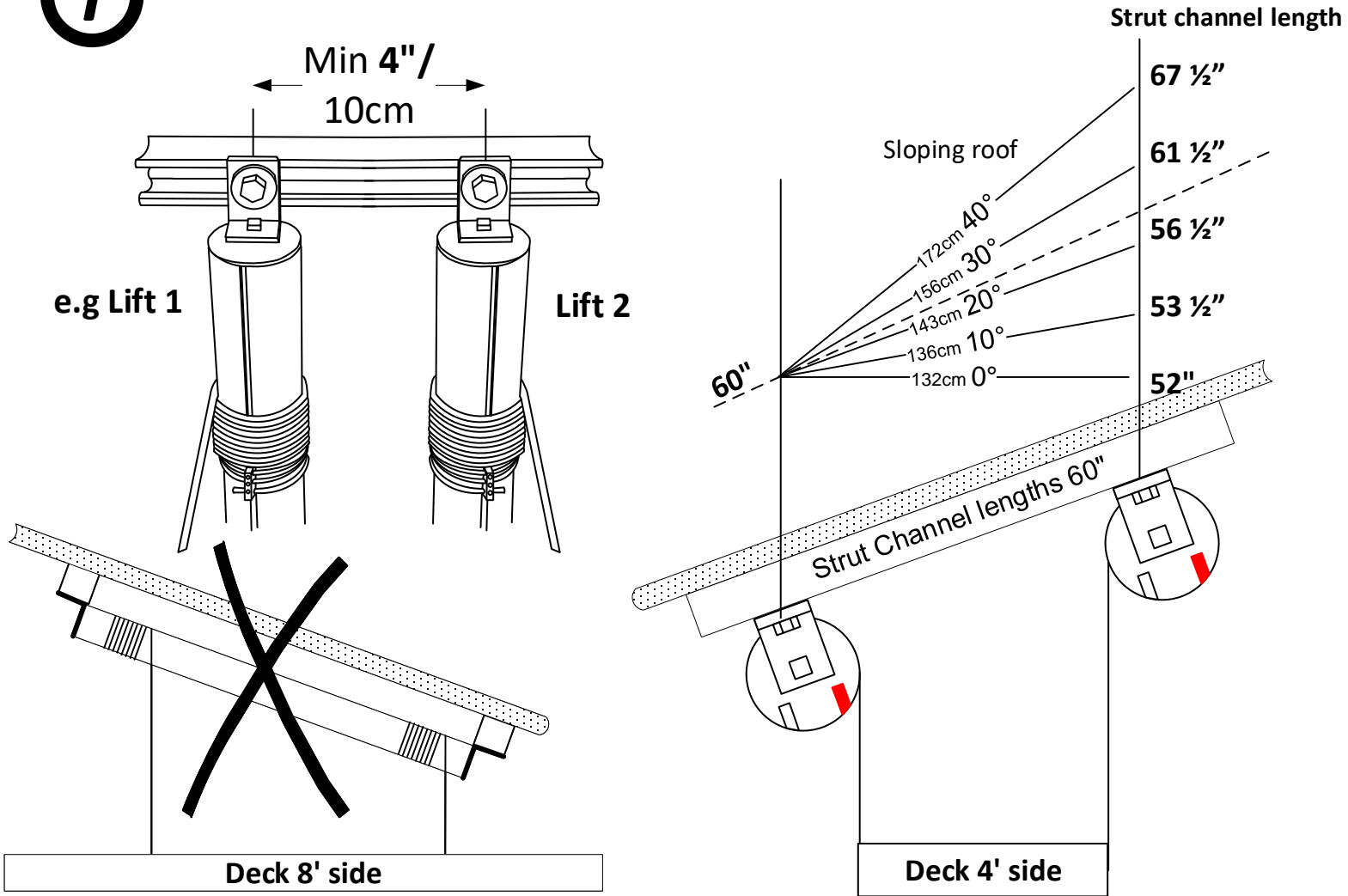

## Maximum Uncoil

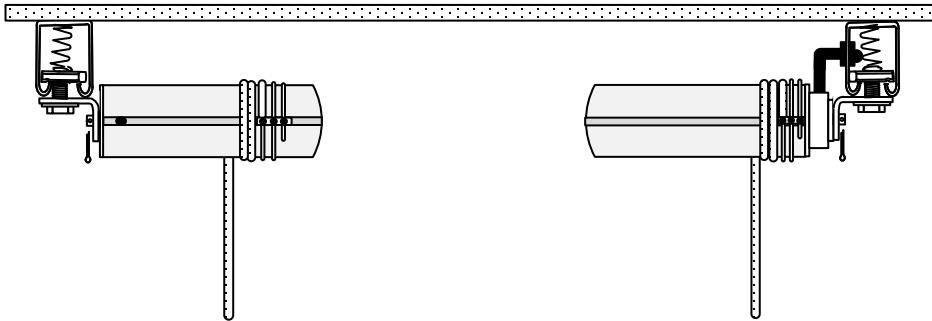

Gap between bracket and motor should not exceed 1/16" / 1mm

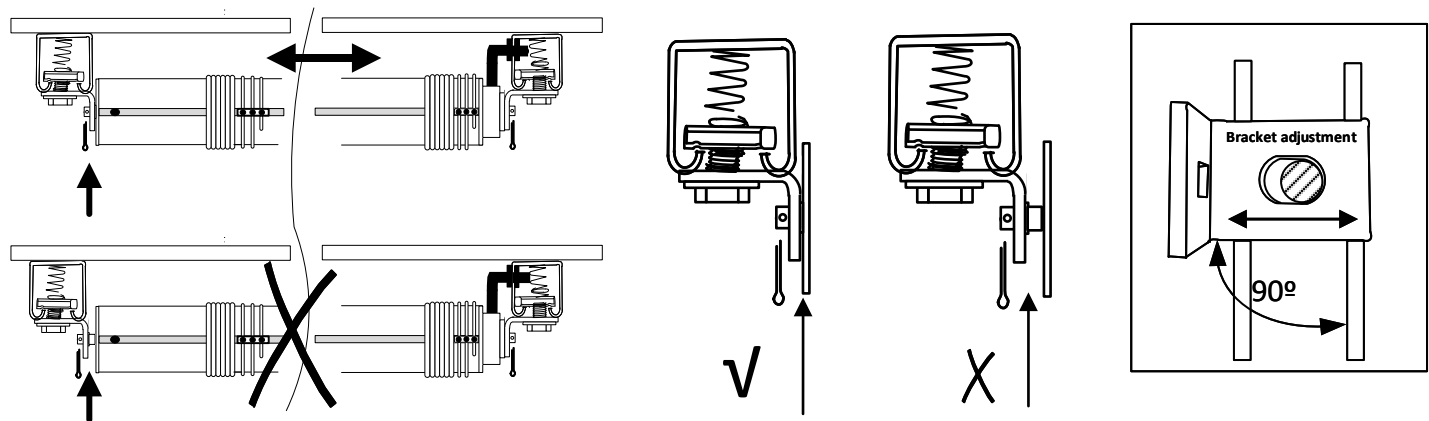

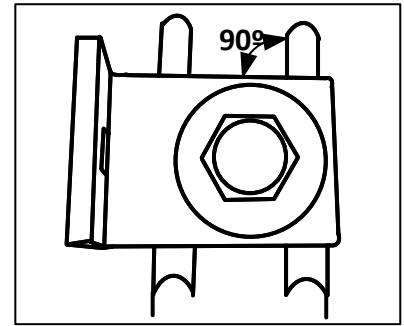
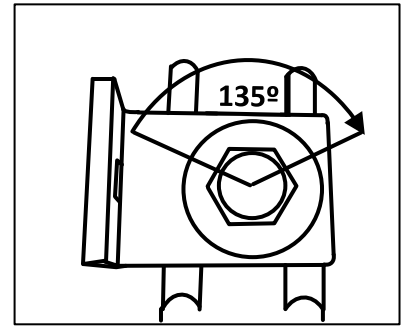
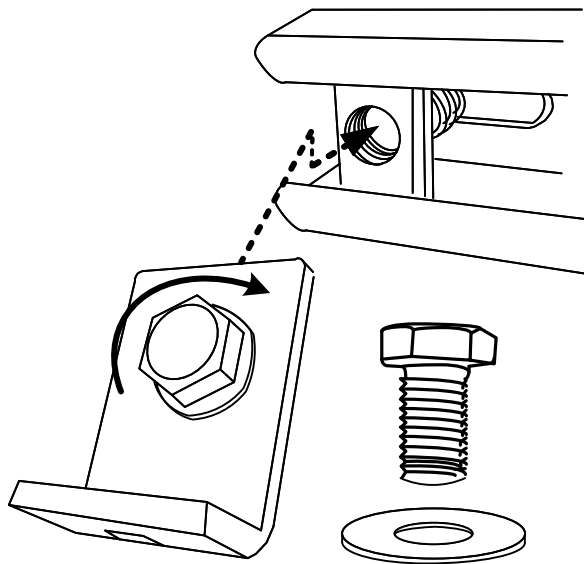
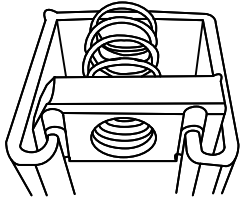

Tighten screw until the washer no longer rotates. Then tighten screw another 135° in the same direction.

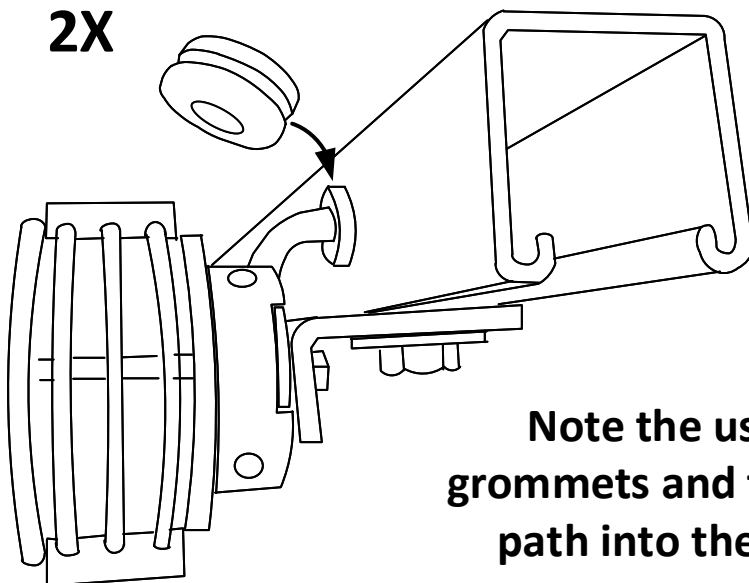
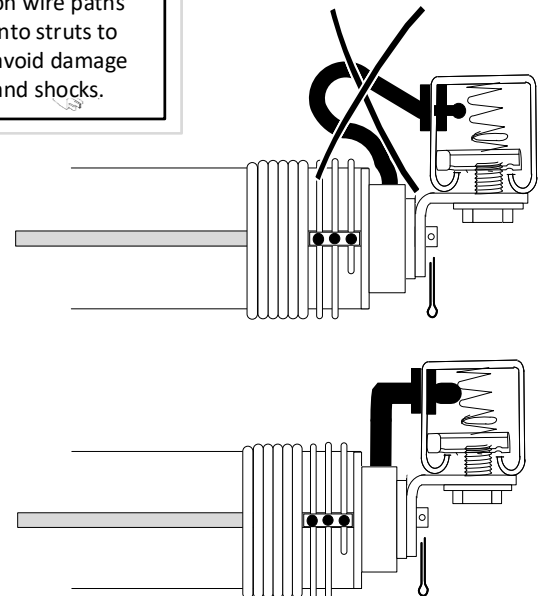
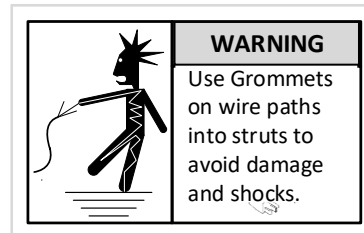
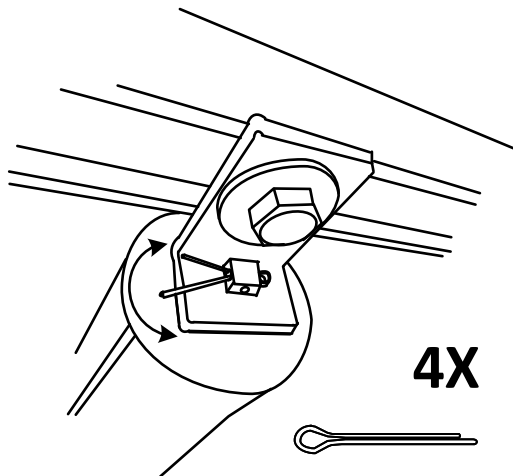
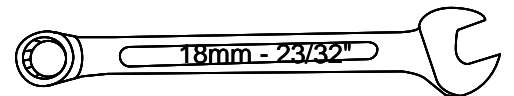

Note the use of grommets and the wire path into the strut





# Options

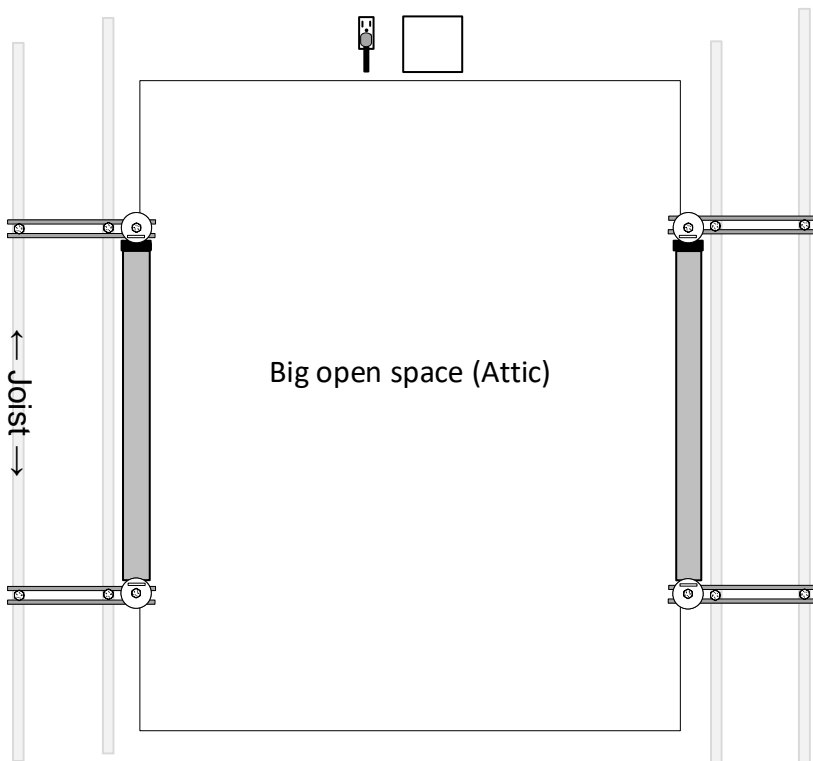
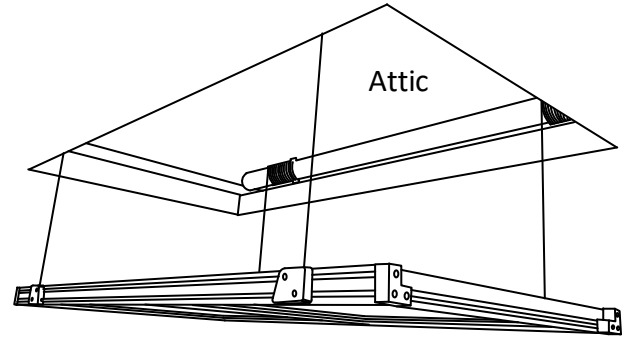
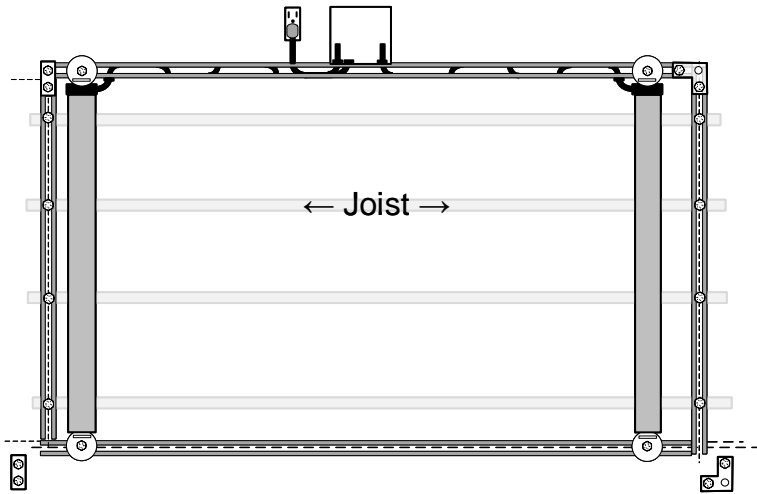
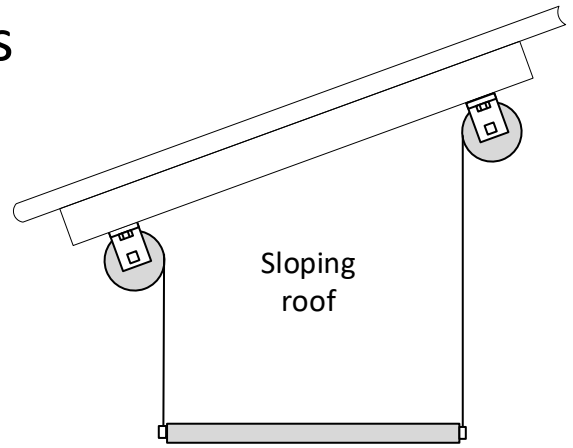
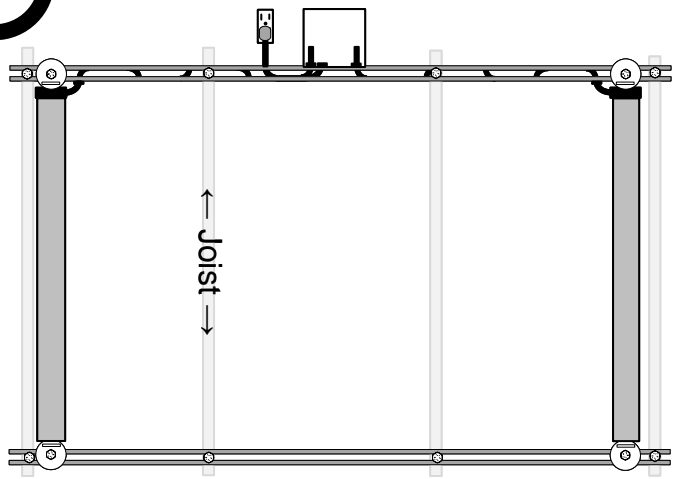

## Projects in which the wire rope lose tension



Wire rope wound up

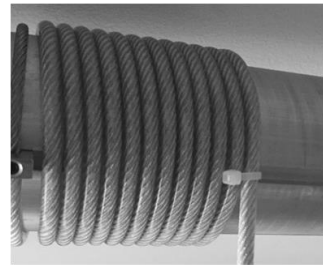

Maximum unwound  
Cable tie tightened around the last two turns



Even without tension the cable wraps are neatly side by side and no overlapping.

# 1

Strut Channels

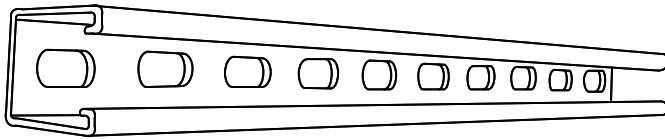

2X



2X

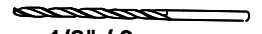
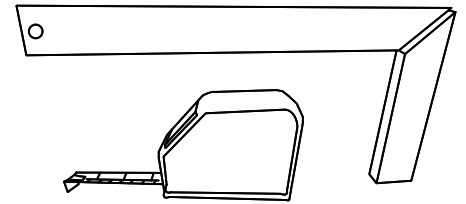

1/8" / 3mm  
(For pilot hole)

### Warning!

DO NOT use an Impact Driver to tighten the Lag screws!  
Tighten screw until the washer no longer rotates.

Then tighten screw another 10° in same direction.

## Min. Required Area

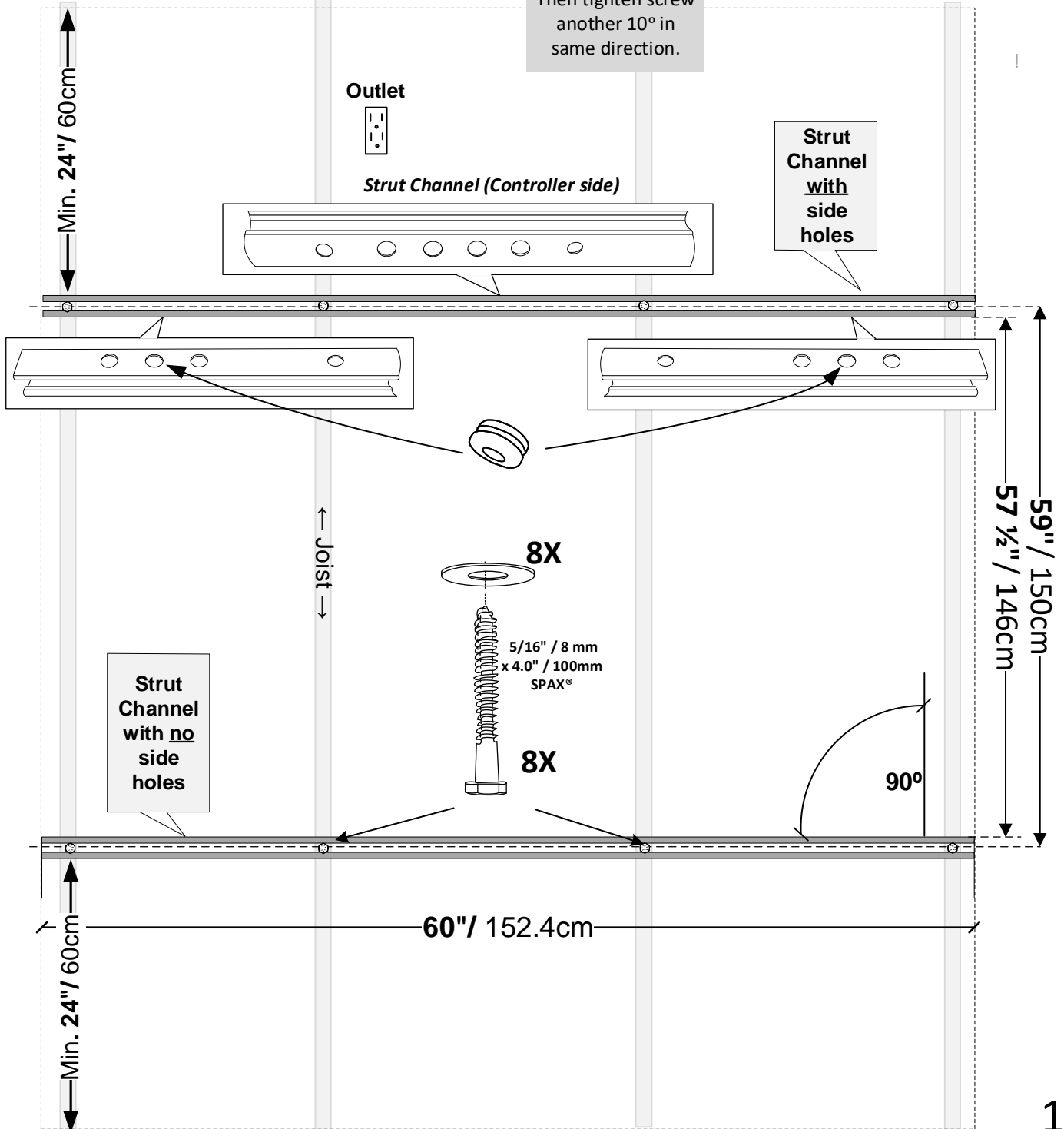

# 2

Strut Channels

## Joists rotated 90° from Standard: Extra Strut Channels required (not included)

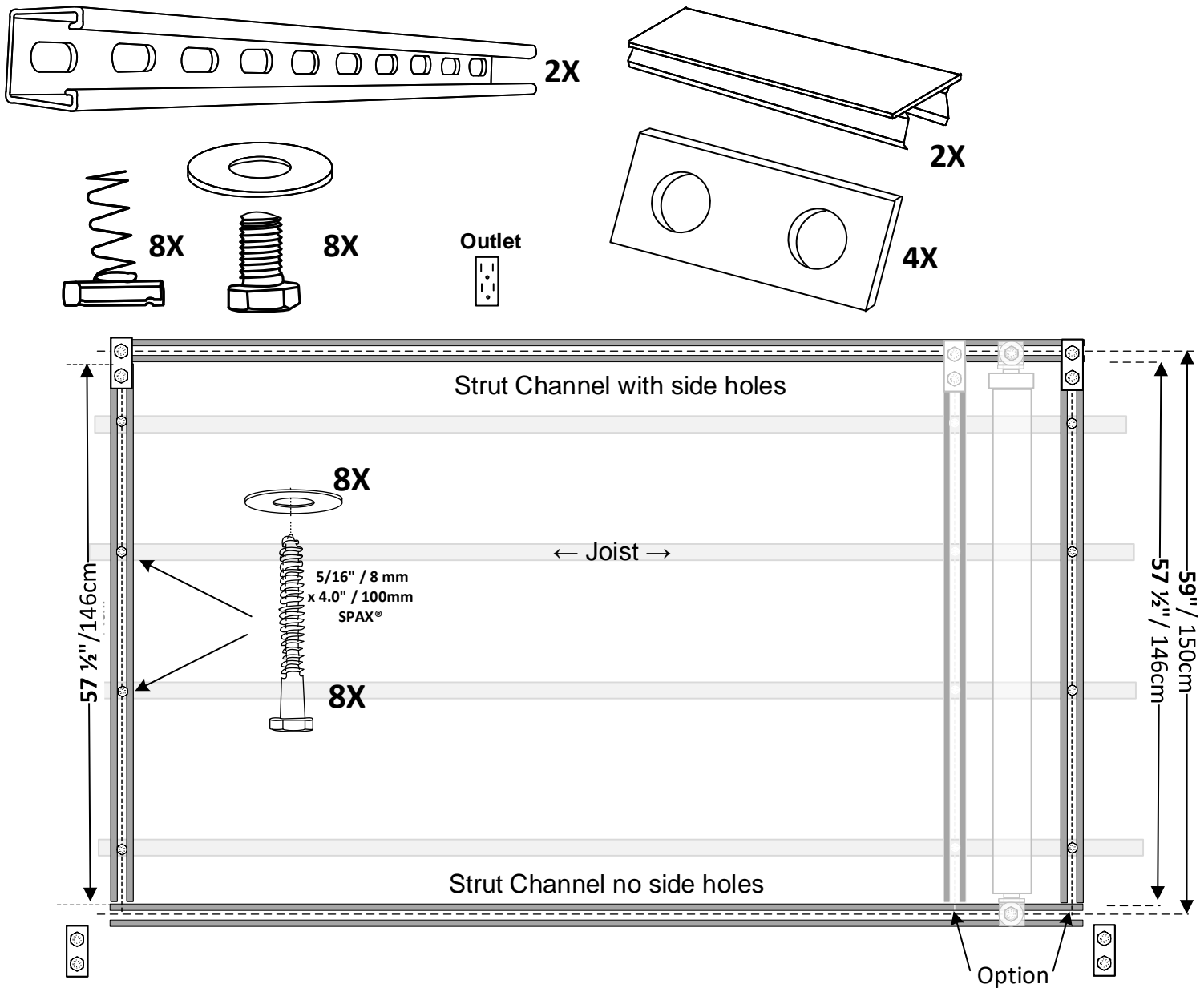

Extra material for this configuration is not included. You will find the below materials at any big-box hardware store or order it from us (contact us).

1x Strut Channel 10'

8x Strut Spring Nuts 1/2"

8x Strut Screws Hex-Head Bolt

4x Strut Brackets

Model # ZA12HS10EG

Model # ZA1001/2EG-10

Model # ZE142121516EG10

Model # ZAB206EG-10

**3**  
Motors

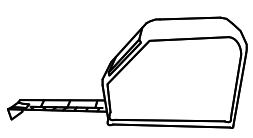
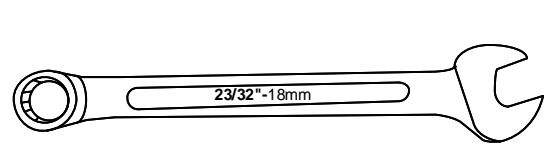

Outlet

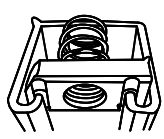

**4X**

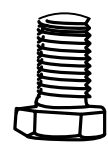
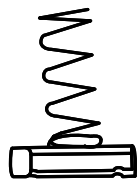

**4X**

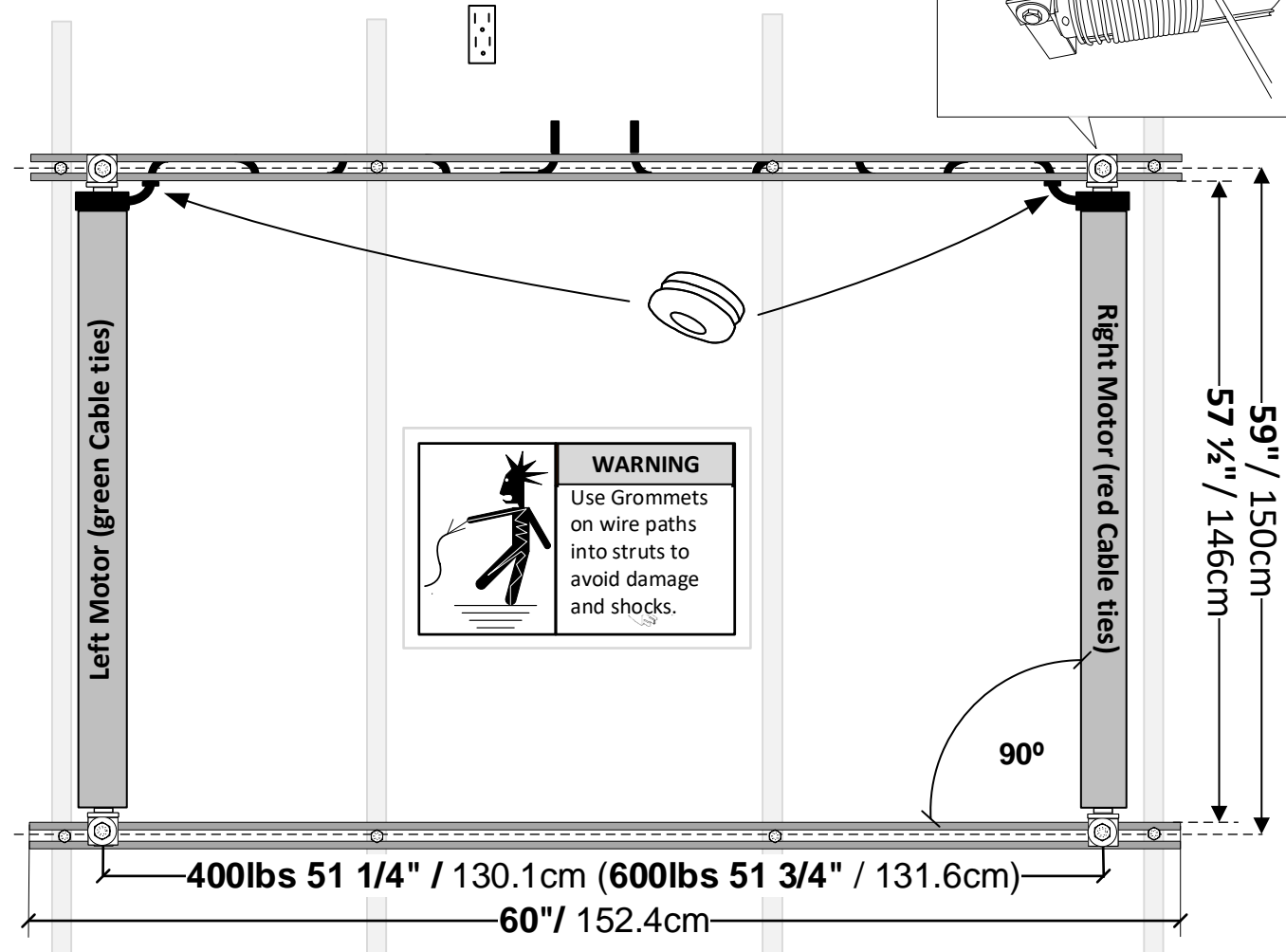
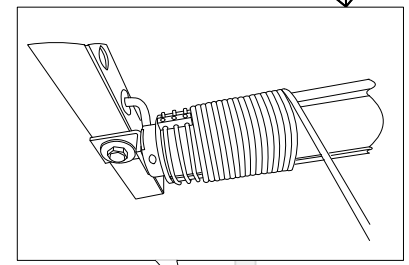
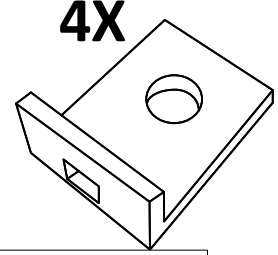

*If Lift platforms are 3' x 6' or 3' x 8', install Motors 12" closer together ( -30.48cm )*

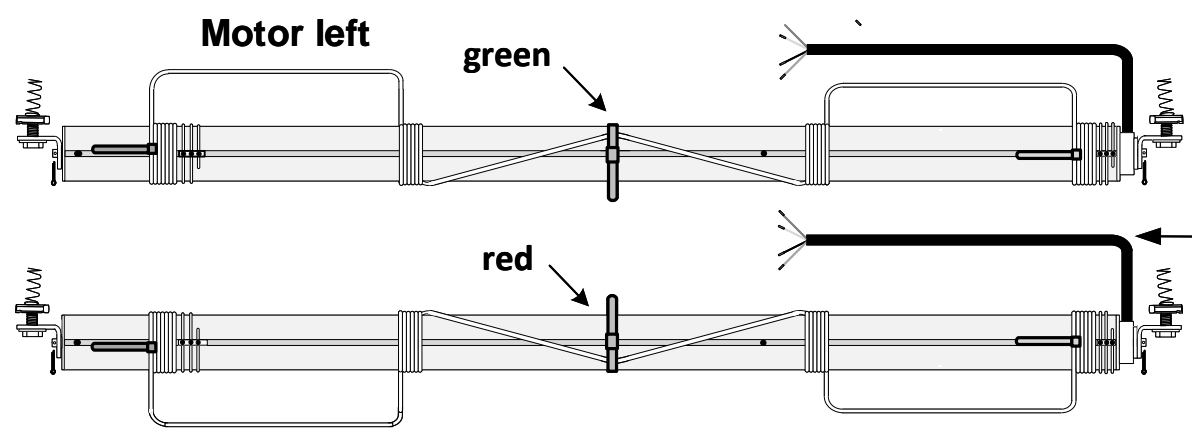

The black cables that come out of the motors need to come straight up towards ceiling.

# 4

Controller

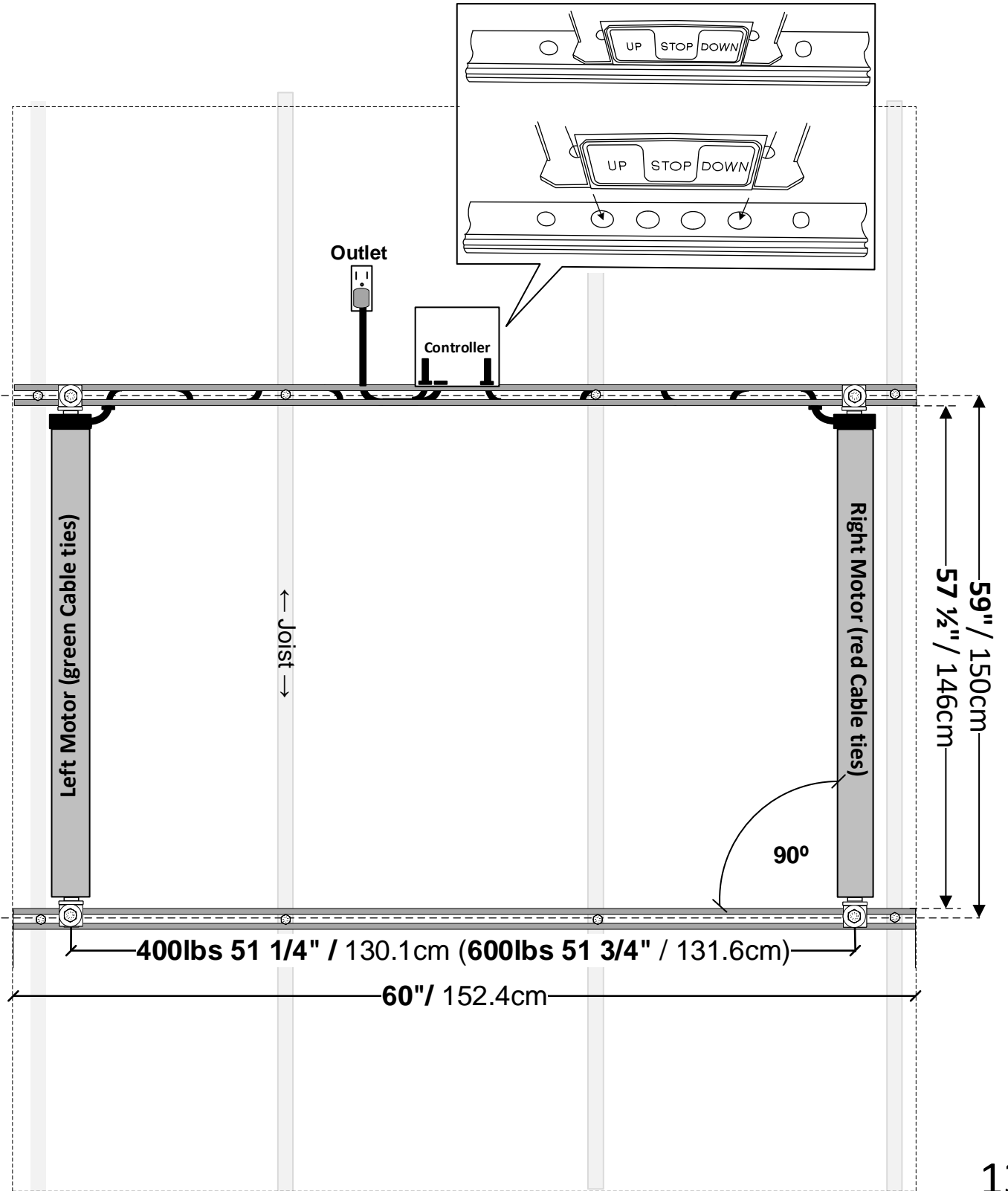
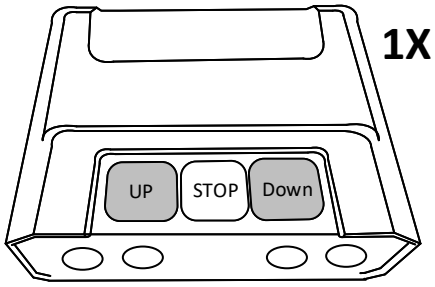

# 5

Controller

## CONTROLLER MOUNTING OPTIONS

### If Drywall/Concrete Ceiling:

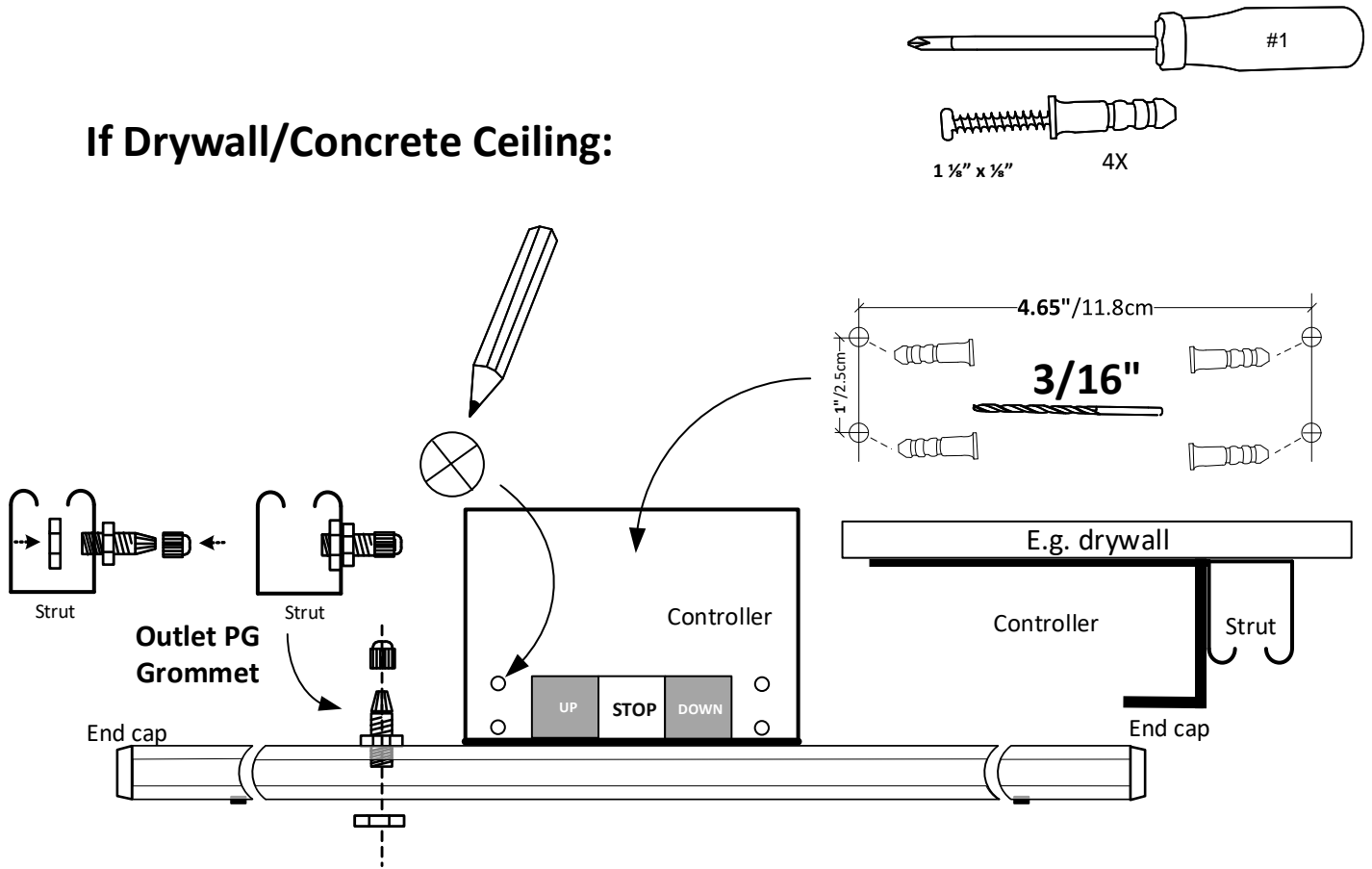

- Use anchors for dry wall/concrete ceilings
- For outlet, always use PG grommets!

### If NO Drywall/Concrete Ceiling (open ceiling):

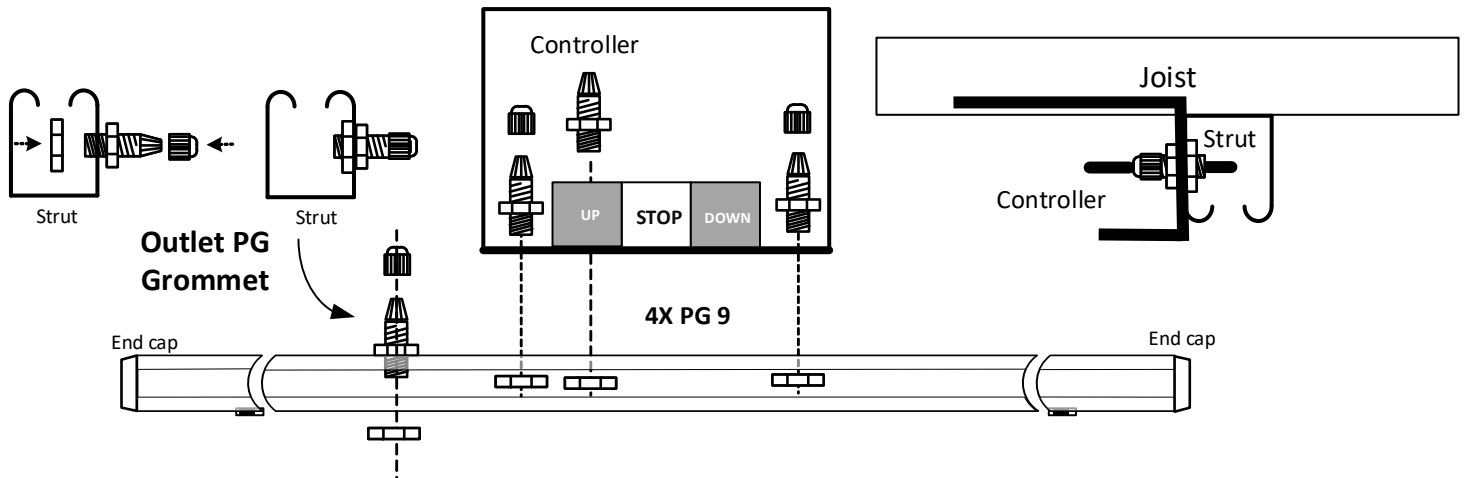

- PG grommets: If you have only joists, not e.g. drywall.
- For outlet, always use PG grommets!

# 6

## Wiring

# Controller wiring

Several options are available to route the power cable to the nearest outlet.

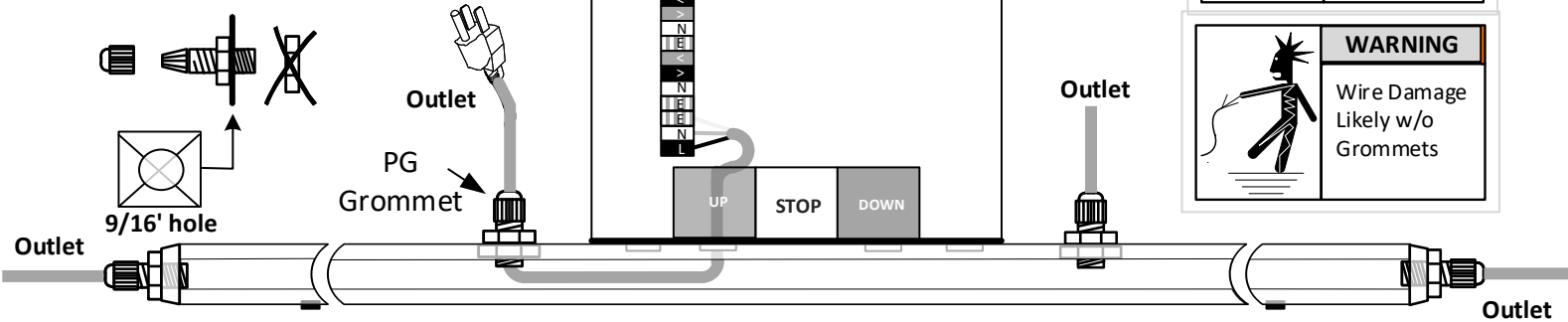

**WARNING**  
Shock Hazard  
Disconnect power before working on wiring

**WARNING**  
Wire Damage  
Likely w/o Grommets

- |          |   |         |
|----------|---|---------|
| BLACK bl | < | Down    |
| RED rd   | > | UP      |
| WHITE wt | N | Neutral |
| GREEN gn | E | Earth   |
| RED rd   | < | Down    |
| BLACK bl | > | UP      |
| WHITE wt | N | Neutral |
| GREEN gn | E | Earth   |
| GREEN gn | E | Earth   |
| WHITE wt | N | Neutral |
| BLACK bl | L | Hot     |

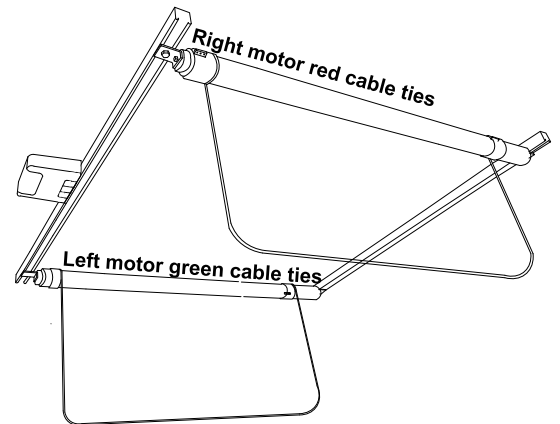

# Motor wiring

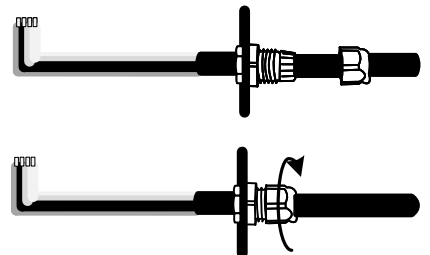
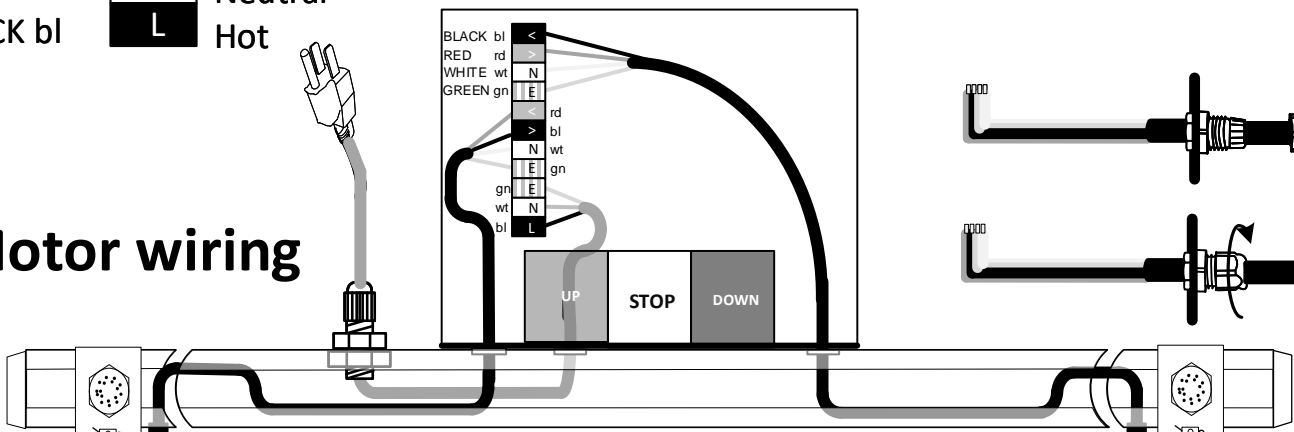

**Left Motor**  
Green cable ties

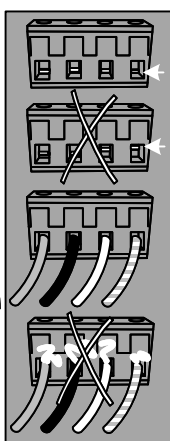
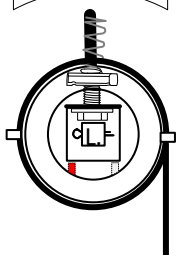

Motor Connector

*Before connecting to the outlet, make sure that all wires are tightly connected*

Wires are connected by tightening binding screws on the top of the green motor connector blocks

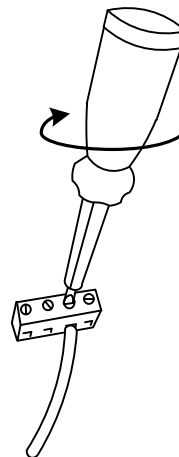

**Right Motor**  
Red cable ties

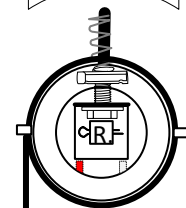

# 7

## Wire rope

**Left Motor, green cable ties**

**Cable in direction ceiling**

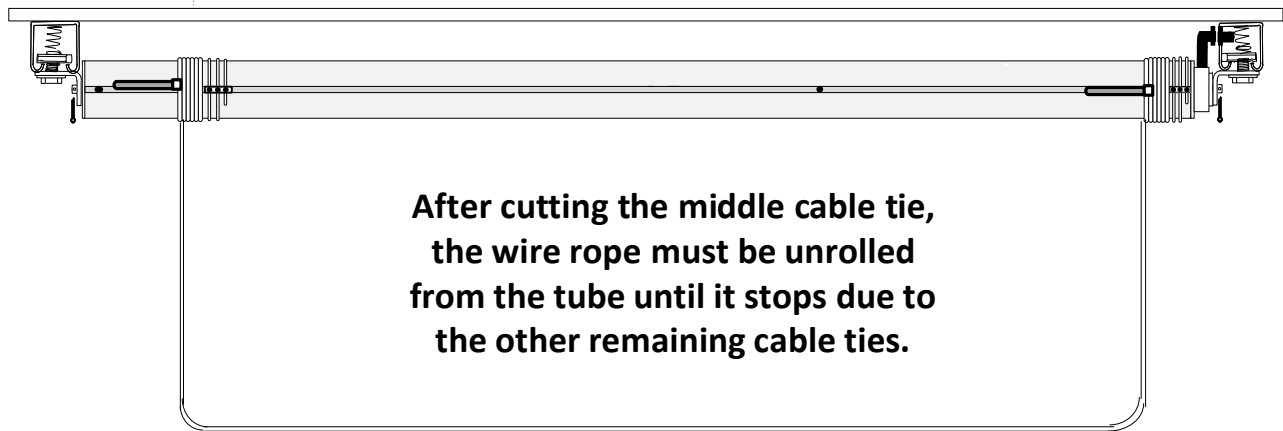
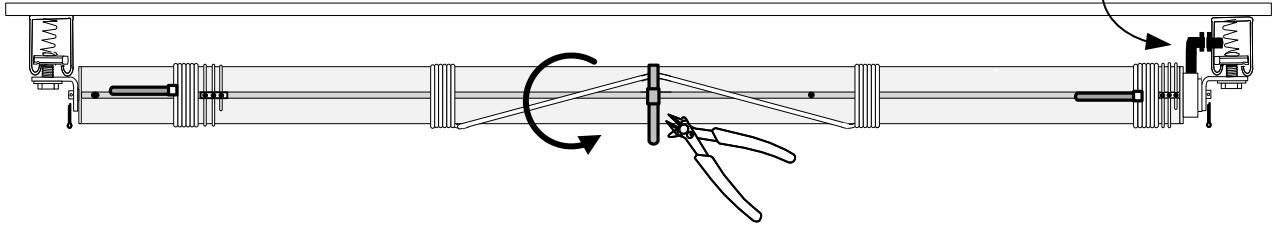

**Left motor  
Green cable ties**

**Right motor  
Red cable ties**

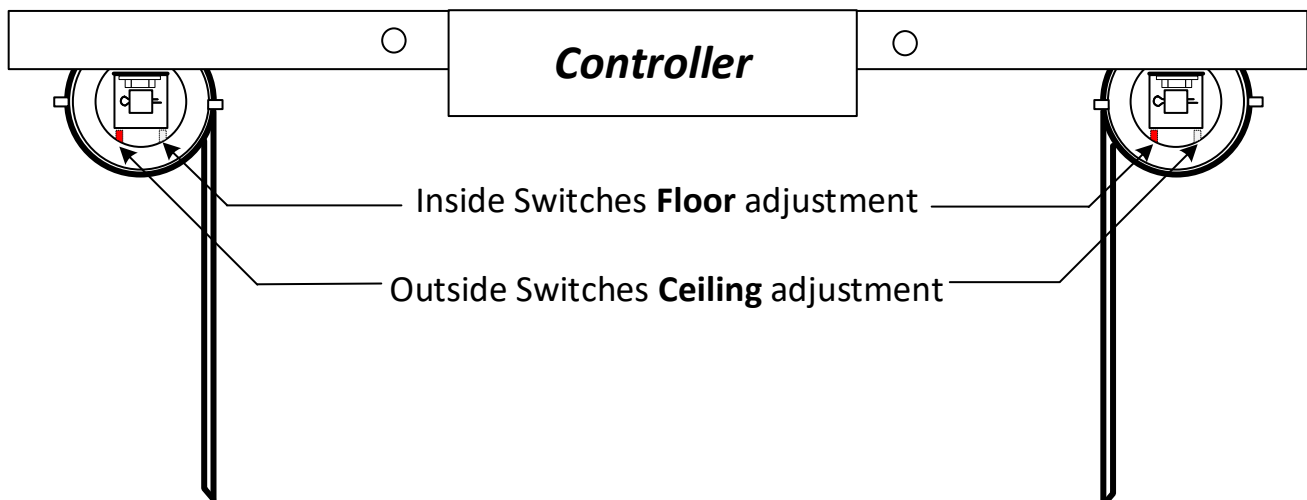



# 8

## Platform

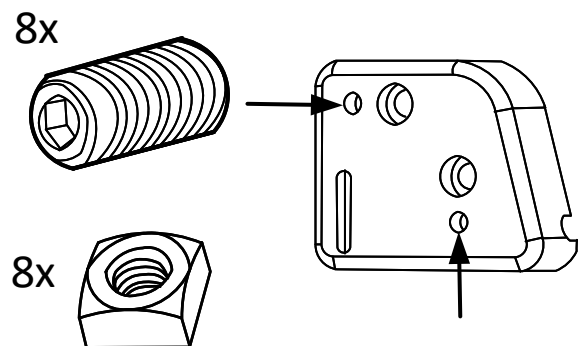
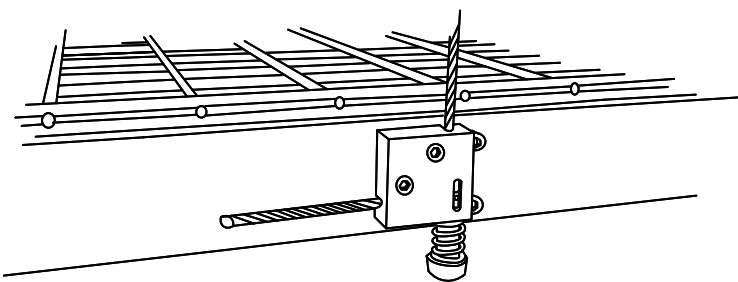
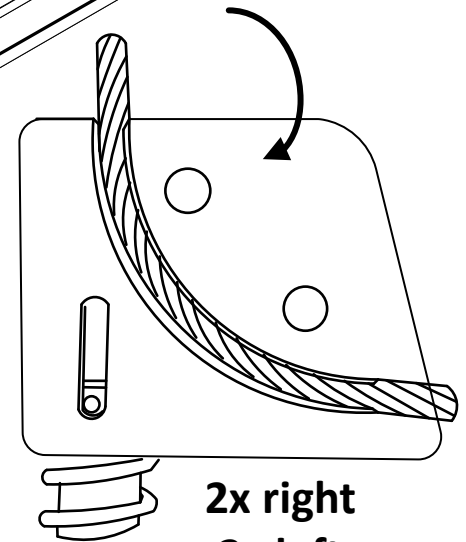
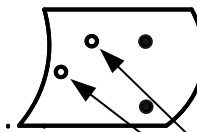
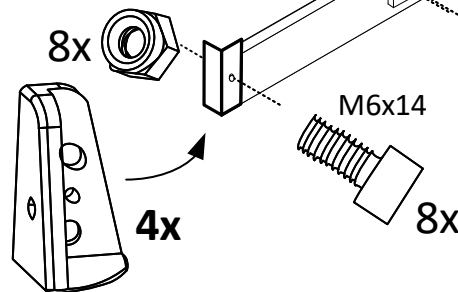
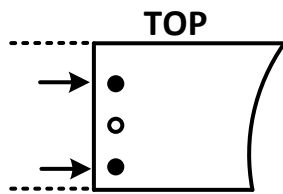
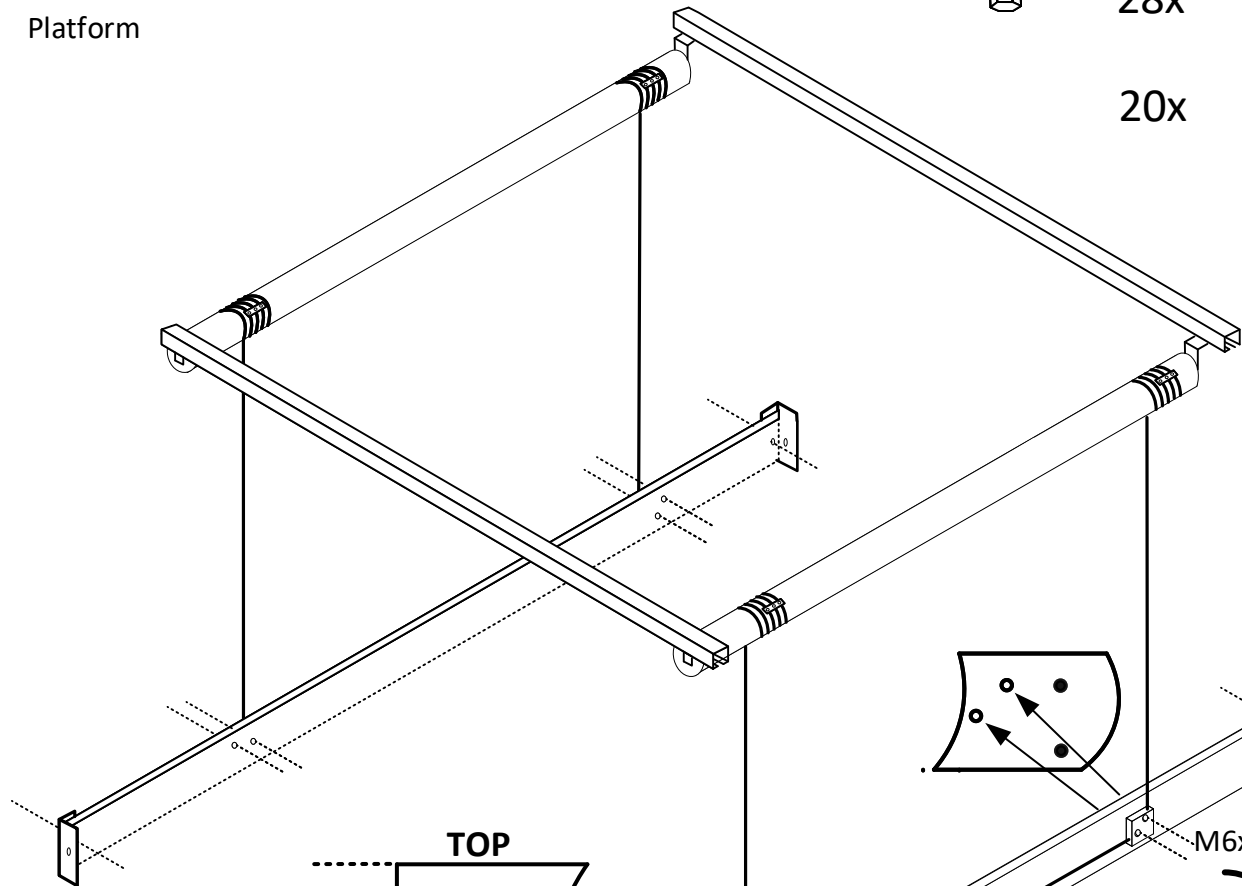
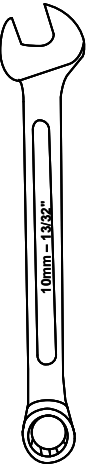
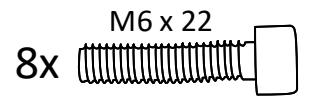
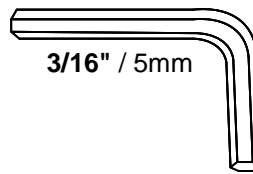

# 9

## Platform

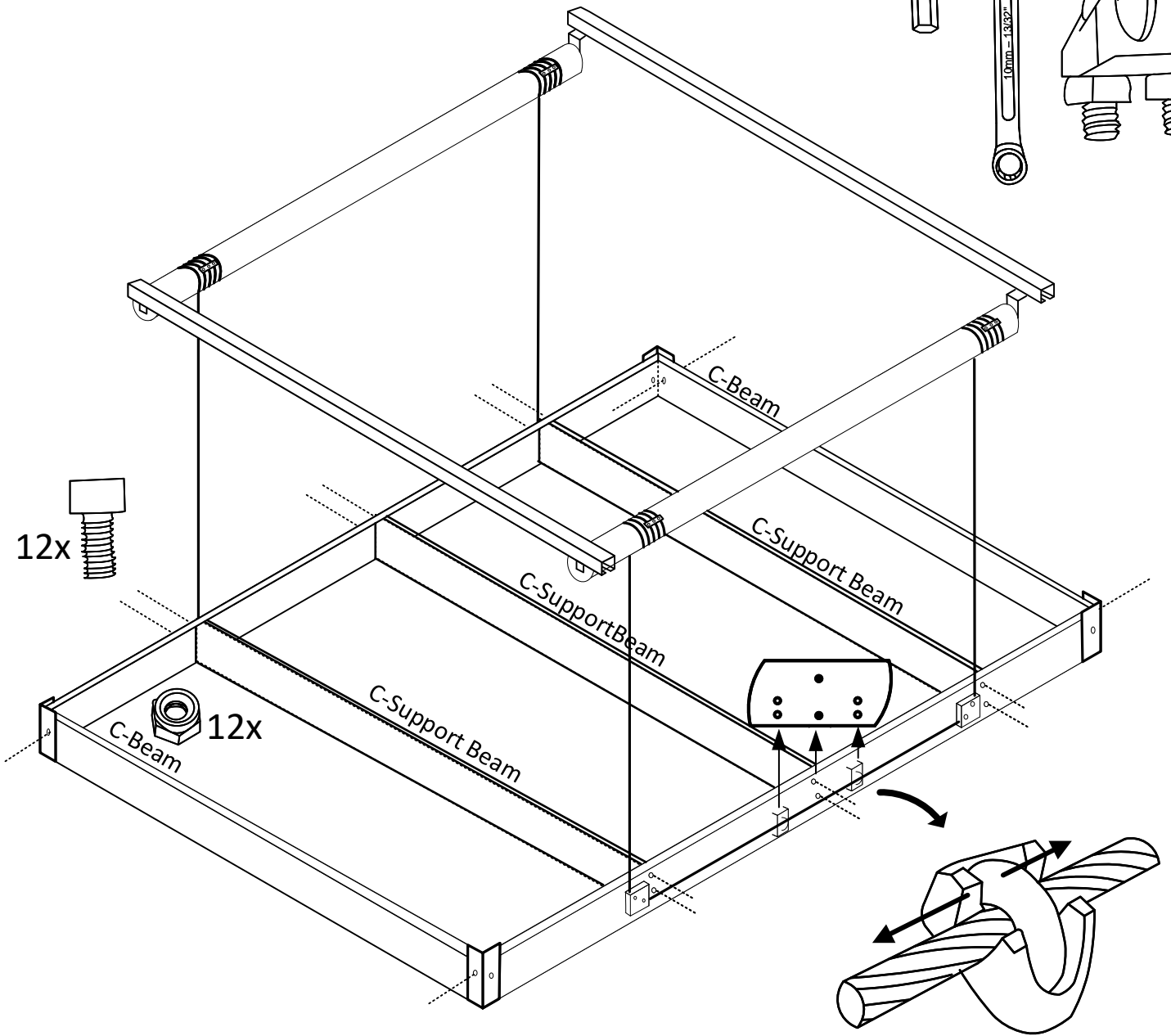
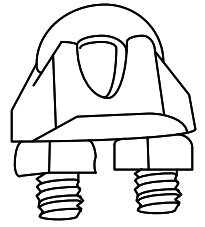
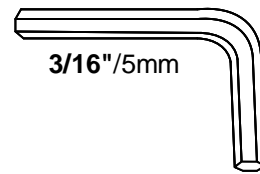

**Do not  
tighten yet!**

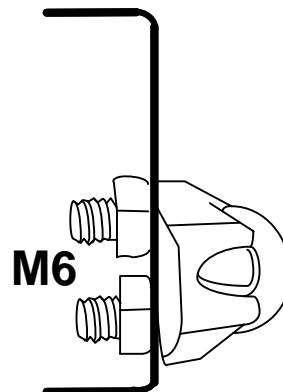
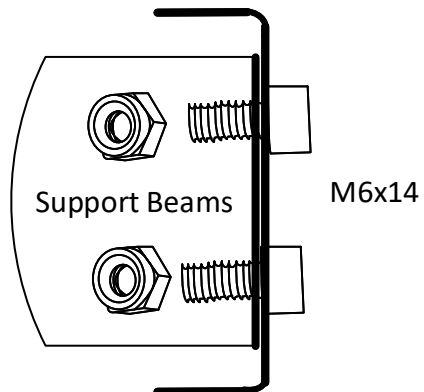

# 10

## Length Beam adjustment

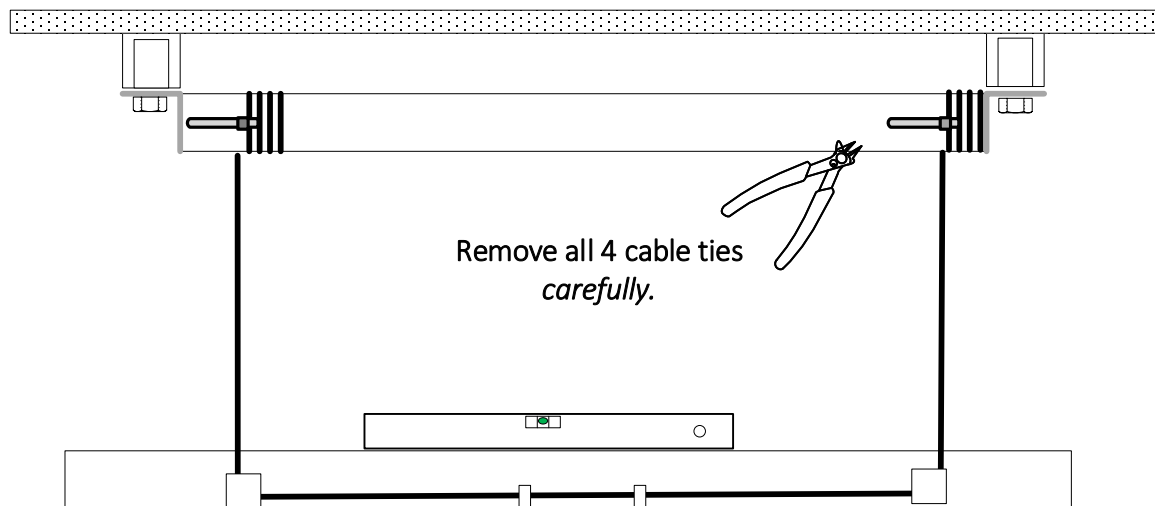
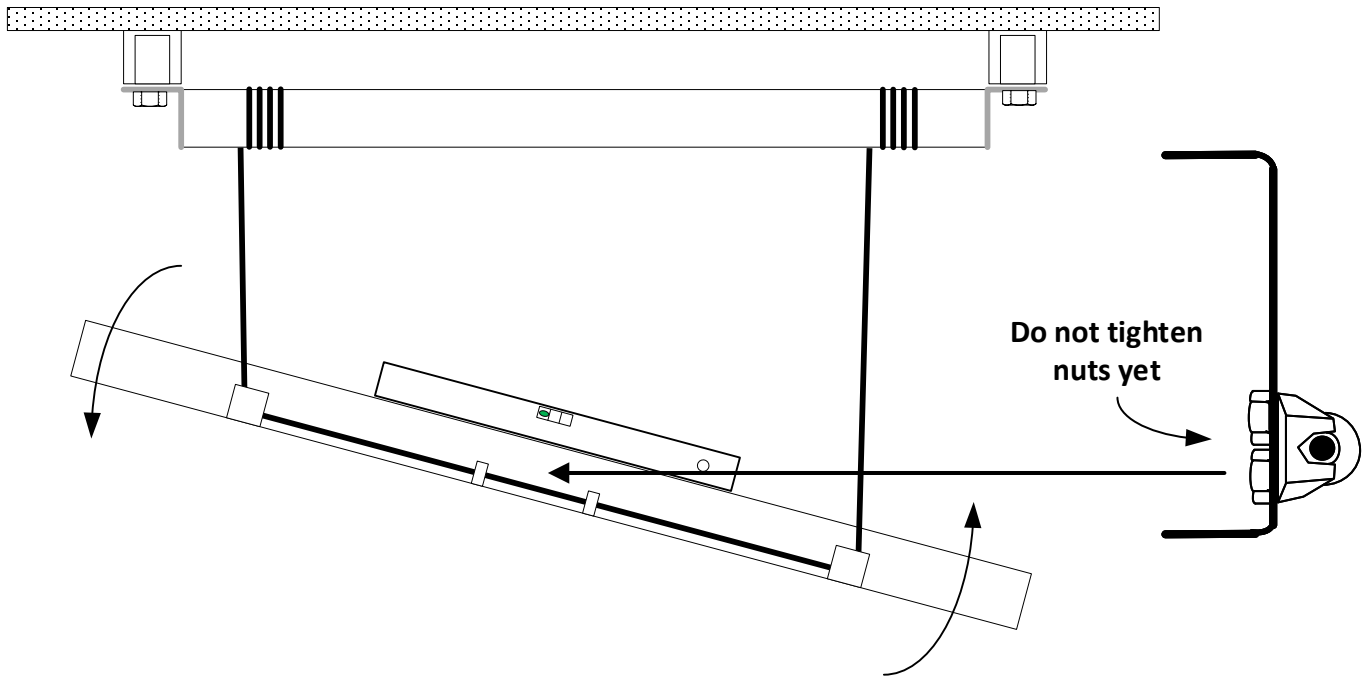
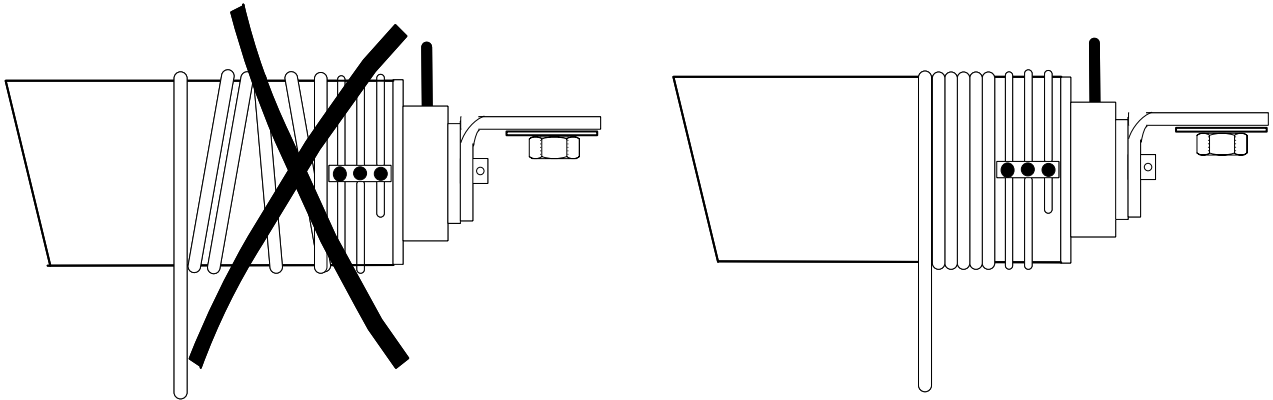



# Overview Controller

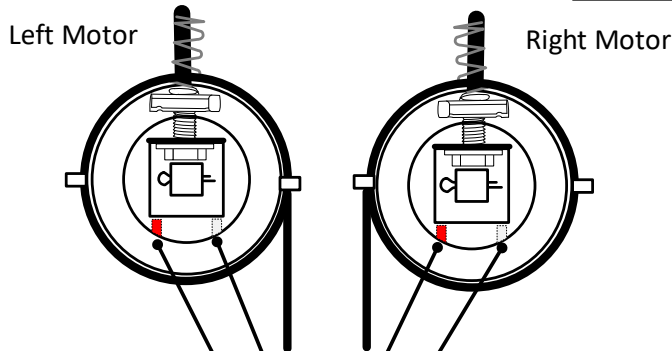
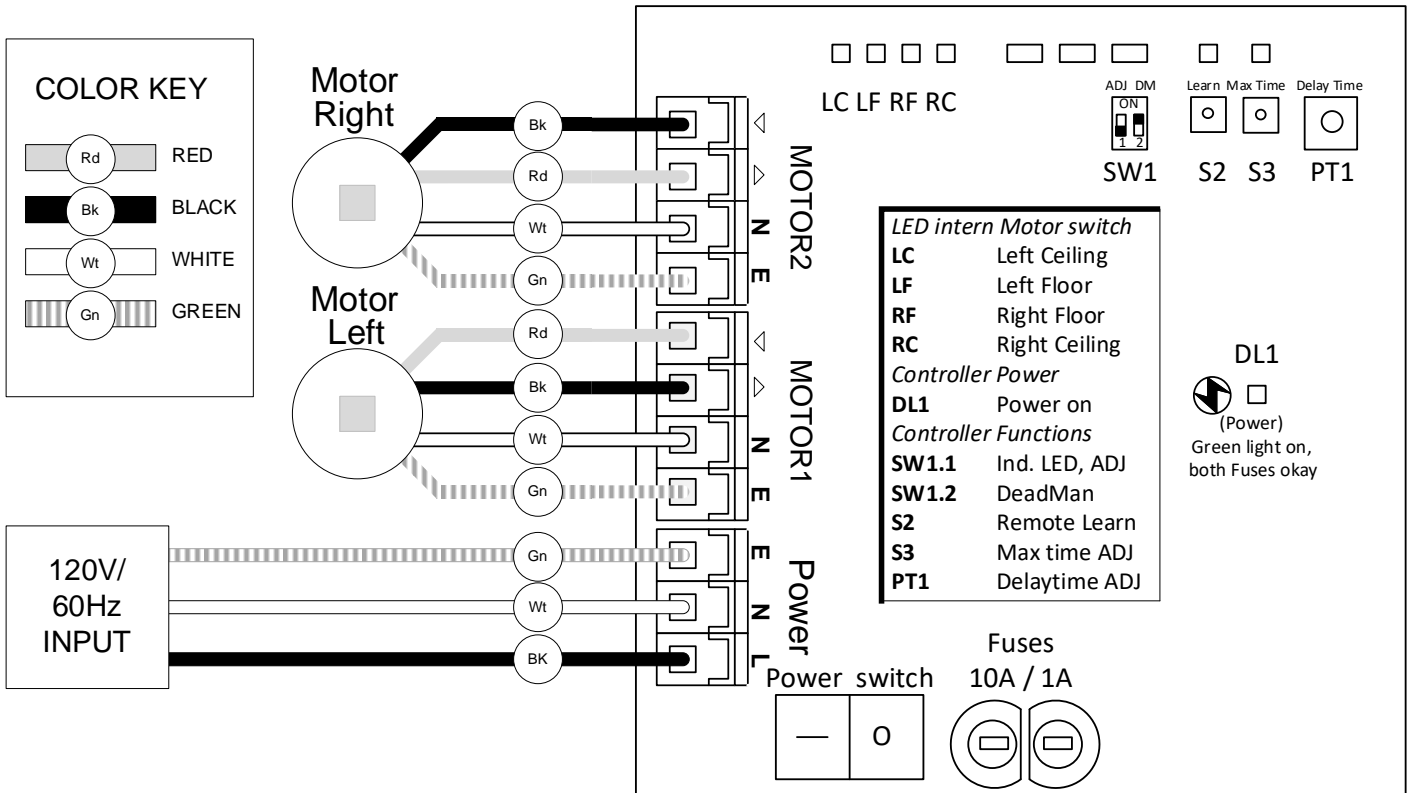
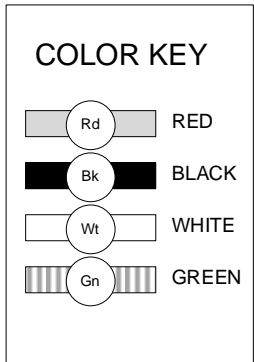

## IMPORTANT MOTOR ARRANGEMENT

If you change something the manual doesn't fit anymore!

*Lift doesn't work in this mode, only control and pre adjustment!*

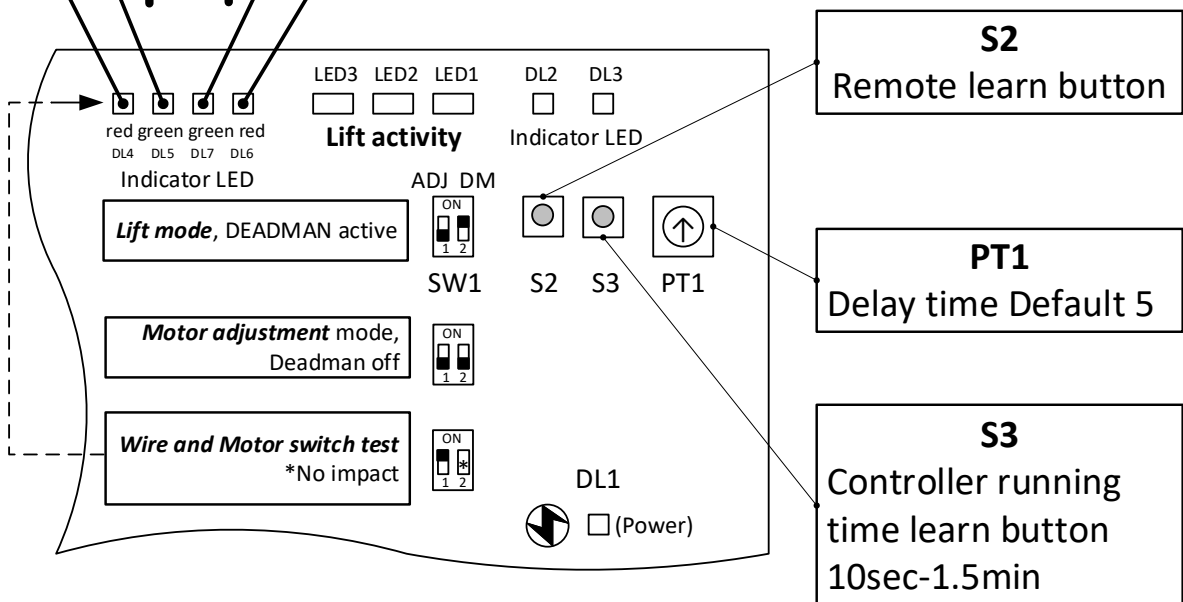



# Motor Adjustment (leveling), Preparation

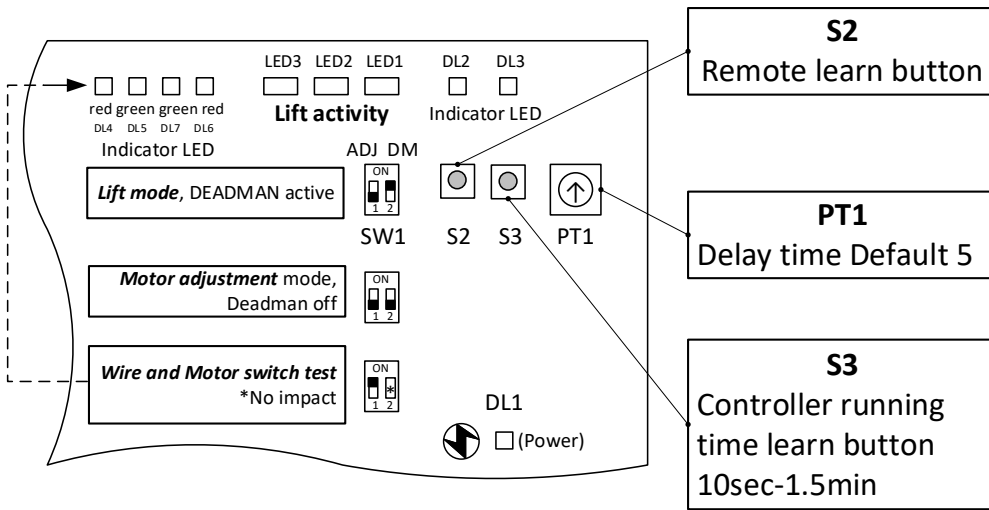

**DeadMan off- press key (up/down) once and the lift runs. Press STOP 2 This function for adjustment only!**

**Do not use PT1  
S2 and S3 for  
adjustment!**

**Most important! All switches work the same way, even though their labeling is different. Before you start to turn the stop (motor limit) switches, please be sure that you are turning them in the right direction!**

## Controller Keys

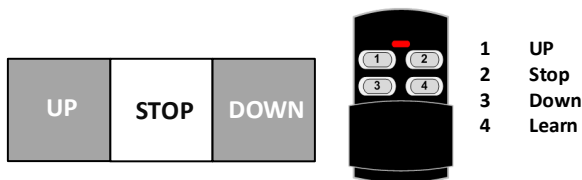

!Max running Time 1.5min

Stop floor adjustment  
1/8" before the legs  
touch the floor!

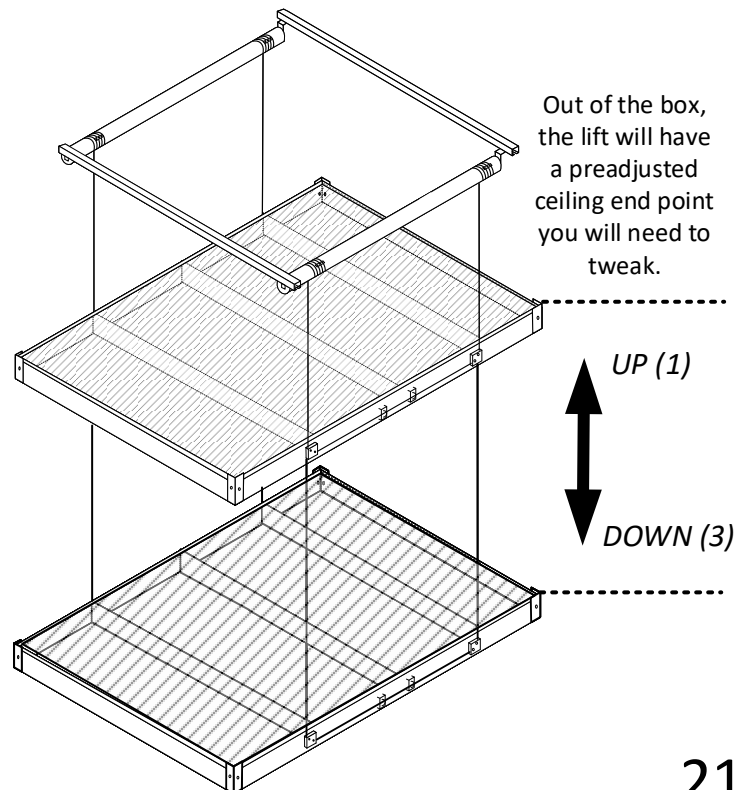
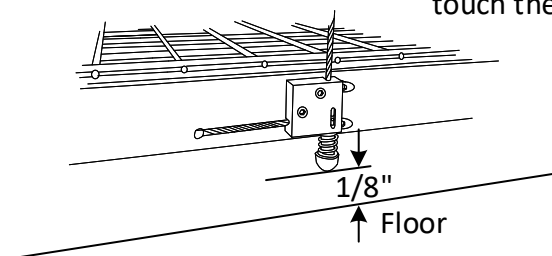



# Motor Adjustment (leveling), Preparation

## Technical information for 400 lbs lift

Max travel is	15.4 feet/ 4.70m & storage
1 tube rotation	12 turns on the stop switches
1 tube rotation	9" / 22cm
1 turn on stop switch	3/4" / 2cm
Smallest movement	1/16" / 1mm
Movement Rack 14'*	4"/10cm
Switch turns	250
Travel speed	8'/min

## Technical information for 600 lbs lift

Max travel is	21.8 feet/ 6.40m & storage
1 tube rotation	12 turns on the stop switches
1 tube rotation	11" / 28cm
1 turn on stop switch	1" / 2.5cm
Smallest movement	1/16" / 1mm
Movement Rack 14'*	4"/10cm
Switch turns	300
Travel speed	10'/min

Only turn the switches by hand with the tool provided  
 Stop turning immediately if you feel a mechanical click in the  
 switch when turning.

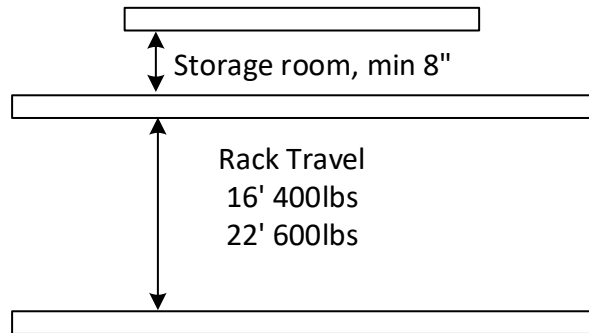
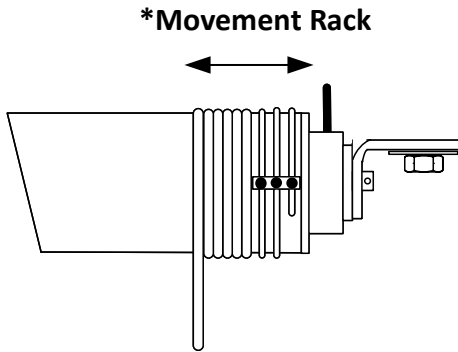

Adjustment is only possible with the **DeadMan switch OFF**, and after a motor limit has been reached or lift is stopped manually (white LED lights on controller are lit and stay on).

<input type="checkbox"/> <input type="checkbox"/> <input type="checkbox"/> <input type="checkbox"/> red green green red DL4 DL5 DL7 DL6 Indicator LED	LED3 LED2 LED1 <input type="checkbox"/> <input type="checkbox"/> <input type="checkbox"/> <b>Lift activity</b>	DL2 DL3 <input type="checkbox"/> <input type="checkbox"/> Indicator LED
	ADJ DM  SW1	 S2 S3 PT1
<p><b>After adjustment you MUST switch the DeadMan back on. It's for your safety!</b></p>		DL1 (Power)

**DeadMan Function:** You use only the UP and DOWN buttons. You have to hold the button to make the lift move. When you release the button the equipment will stop immediately. If a key gets jammed you can stop the equipment with the stop button.

# 11

## Prepare Adjustment

Wire and Motor test

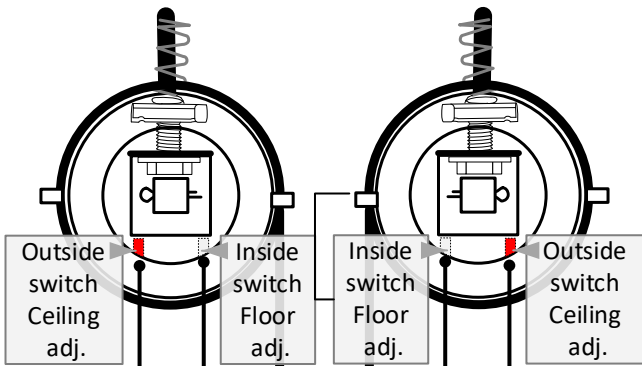
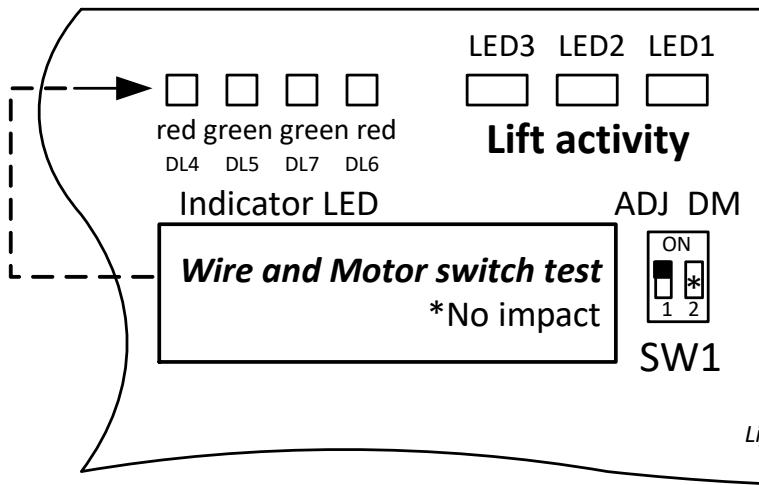

Indicator LED's Status   on off

red DL4	<input type="checkbox"/>	green DL5	<input type="checkbox"/>	green DL7	<input type="checkbox"/>	red DL6	<input type="checkbox"/>	<ul style="list-style-type: none"> <li>• Motors are working</li> <li>• Motors are at the ceiling position</li> <li>• Motors are at the floor position</li> <li>• Left Motor is overheated or misadjustment, wait for 20 min.</li> <li>• All Motors overheated or misadjusted, wait for 20min.</li> <li>• Did you wait for 20min (nothing happened)? Turn all Motor switches 40 times lefty loosy (+) until all LED's are back on.</li> <li>• Turn inside (left Motor) -and Outside switch (right Motor) until all LED's are on.</li> <li>• Step2: Turn all switches righty tighty (-) until all LED's off.</li> <li>• Step3: Turn all Motor switches 30 times lefty loosy (+).</li> </ul> <hr/> <ul style="list-style-type: none"> <li>• Did you turn the left Motor inside switch more than40 times? And the LED still off? Please control the electrical wiring, green connectors and cable screws!</li> </ul>
<input type="checkbox"/>	<input type="checkbox"/>	<input type="checkbox"/>	<input type="checkbox"/>	<input type="checkbox"/>	<input type="checkbox"/>	<input type="checkbox"/>	<input type="checkbox"/>	
<input type="checkbox"/>	<input type="checkbox"/>	<input type="checkbox"/>	<input type="checkbox"/>	<input type="checkbox"/>	<input type="checkbox"/>	<input type="checkbox"/>	<input type="checkbox"/>	
<input type="checkbox"/>	<input type="checkbox"/>	<input type="checkbox"/>	<input type="checkbox"/>	<input type="checkbox"/>	<input type="checkbox"/>	<input type="checkbox"/>	<input type="checkbox"/>	
<input type="checkbox"/>	<input type="checkbox"/>	<input type="checkbox"/>	<input type="checkbox"/>	<input type="checkbox"/>	<input type="checkbox"/>	<input type="checkbox"/>	<input type="checkbox"/>	
<input type="checkbox"/>	<input type="checkbox"/>	<input type="checkbox"/>	<input type="checkbox"/>	<input type="checkbox"/>	<input type="checkbox"/>	<input type="checkbox"/>	<input type="checkbox"/>	
<input type="checkbox"/>	<input type="checkbox"/>	<input type="checkbox"/>	<input type="checkbox"/>	<input type="checkbox"/>	<input type="checkbox"/>	<input type="checkbox"/>	<input type="checkbox"/>	
<input type="checkbox"/>	<input type="checkbox"/>	<input type="checkbox"/>	<input type="checkbox"/>	<input type="checkbox"/>	<input type="checkbox"/>	<input type="checkbox"/>	<input type="checkbox"/>	
<input type="checkbox"/>	<input type="checkbox"/>	<input type="checkbox"/>	<input type="checkbox"/>	<input type="checkbox"/>	<input type="checkbox"/>	<input type="checkbox"/>	<input type="checkbox"/>	
<input type="checkbox"/>	<input type="checkbox"/>	<input type="checkbox"/>	<input type="checkbox"/>	<input type="checkbox"/>	<input type="checkbox"/>	<input type="checkbox"/>	<input type="checkbox"/>	
<input type="checkbox"/>	<input type="checkbox"/>	<input type="checkbox"/>	<input type="checkbox"/>	<input type="checkbox"/>	<input type="checkbox"/>	<input type="checkbox"/>	<input type="checkbox"/>	
<input type="checkbox"/>	<input type="checkbox"/>	<input type="checkbox"/>	<input type="checkbox"/>	<input type="checkbox"/>	<input type="checkbox"/>	<input type="checkbox"/>	<input type="checkbox"/>	
<input type="checkbox"/>	<input type="checkbox"/>	<input type="checkbox"/>	<input type="checkbox"/>	<input type="checkbox"/>	<input type="checkbox"/>	<input type="checkbox"/>	<input type="checkbox"/>	
<input type="checkbox"/>	<input type="checkbox"/>	<input type="checkbox"/>	<input type="checkbox"/>	<input type="checkbox"/>	<input type="checkbox"/>	<input type="checkbox"/>	<input type="checkbox"/>	

! Switch ADJ and DM OFF  
and start with the  
adjustment  
NEXT PAGE's

# 12

Adjustment hints

## Prepare Adjustment

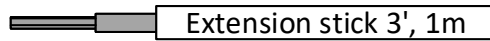
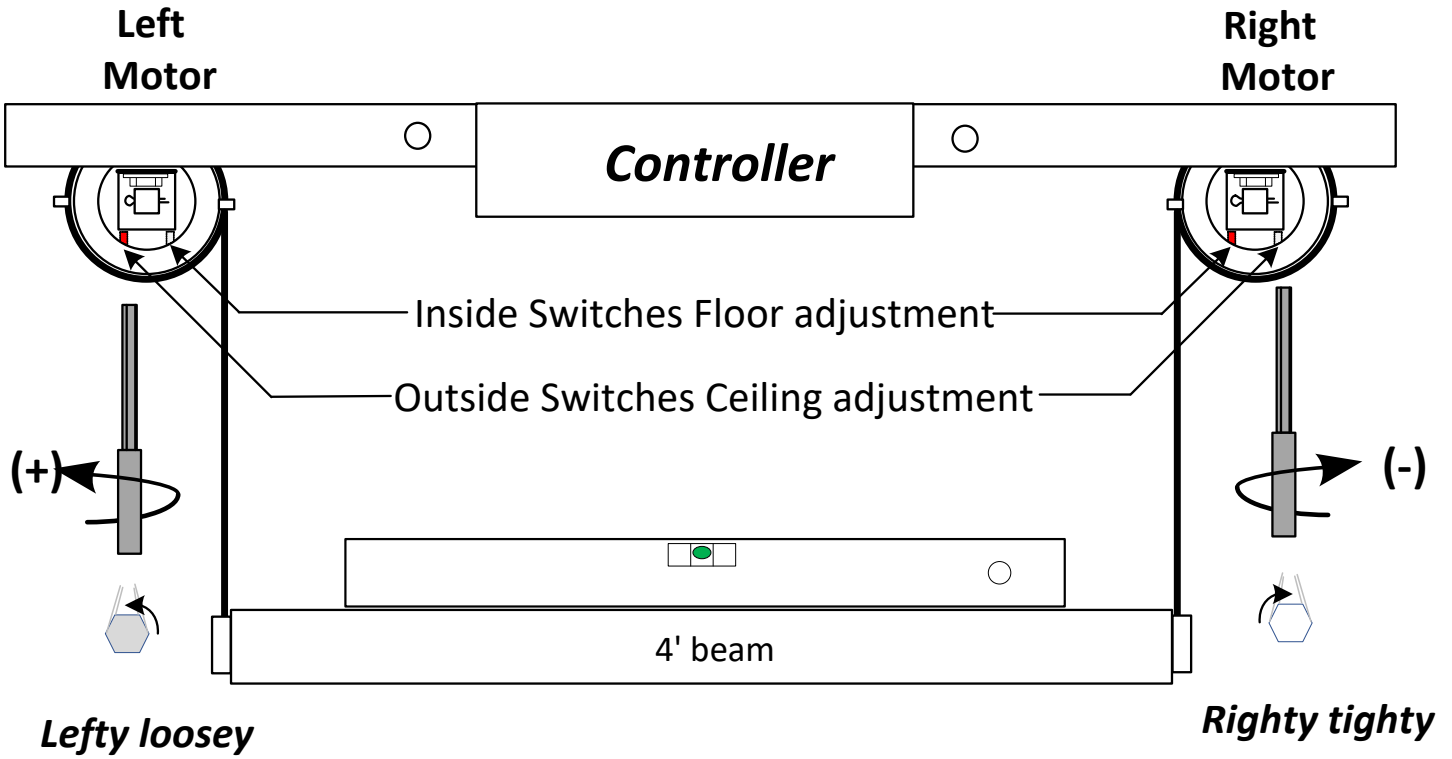

Righty tighty

With an extension stick you can easily adjust the motors from the floor!

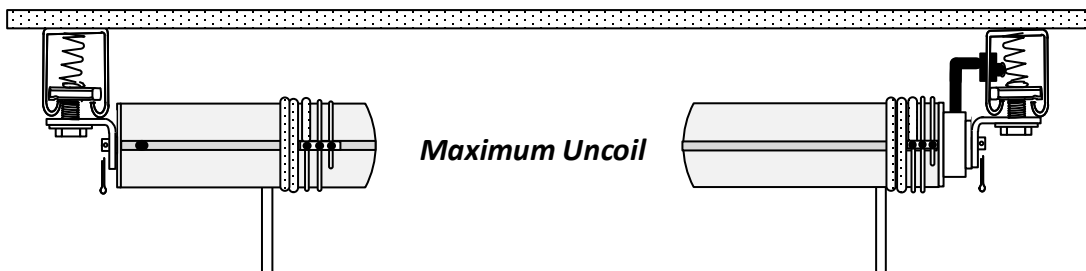
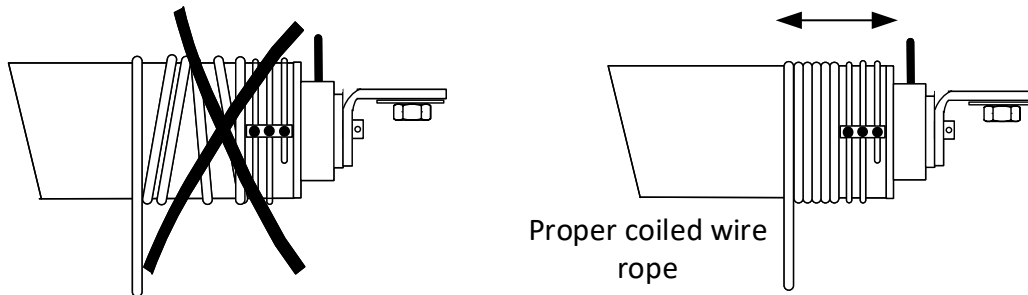



# 13 Level Adjustment

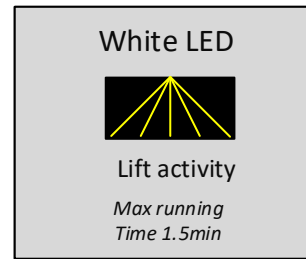
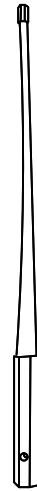
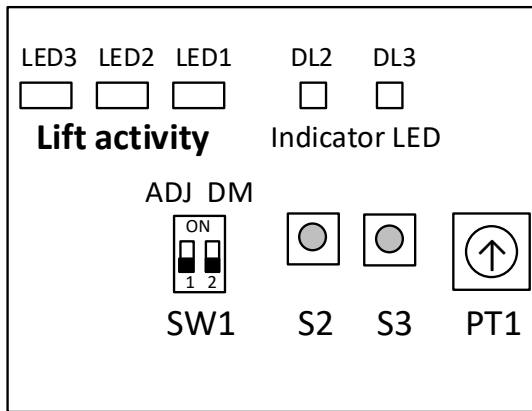

Overheated? Not running just clicking?  
 Motors were running more than 4min?  
 Allow motors to cool for 20min

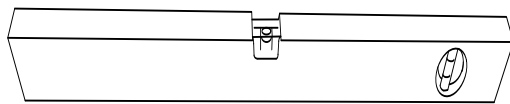
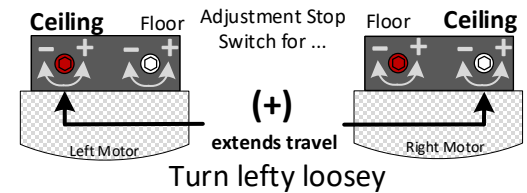
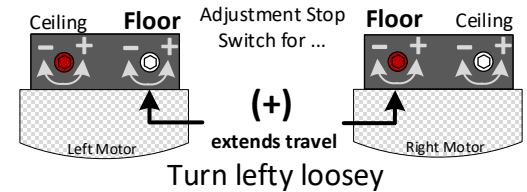
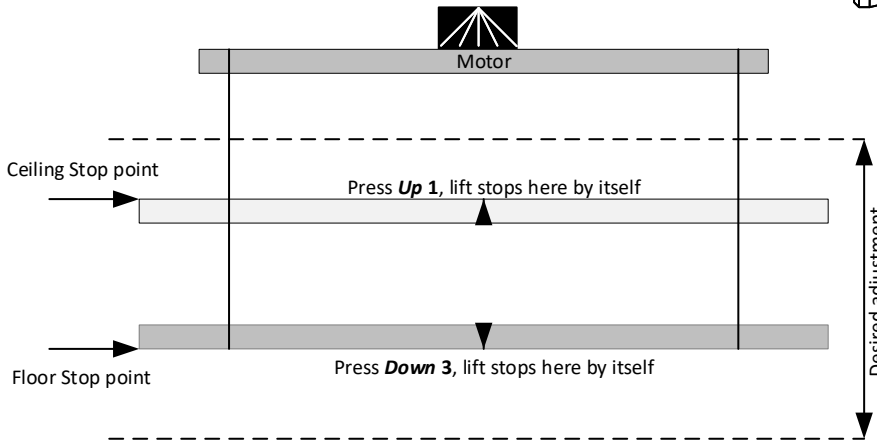

Put a level on the 4'(3') beam and control the levelness of the rack

## Floor Adjustment

## Ceiling Adjustment

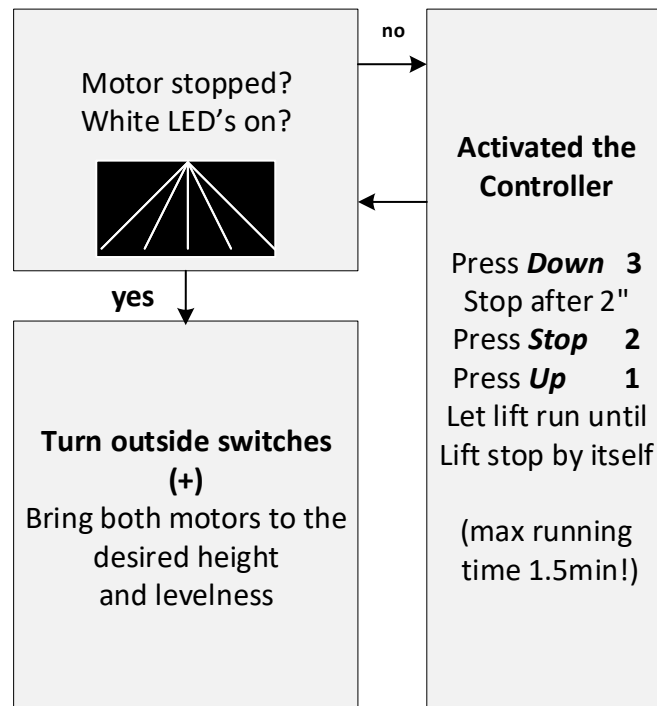
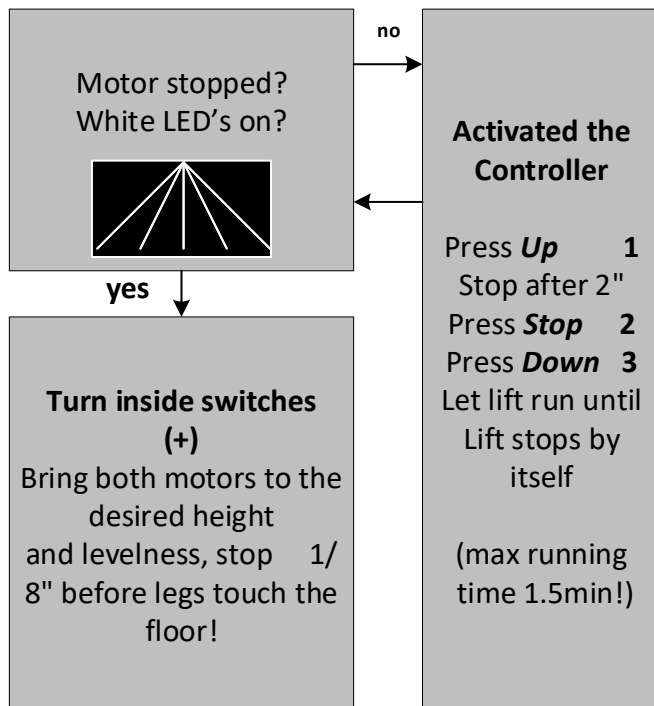

# 14 Level Adjustment

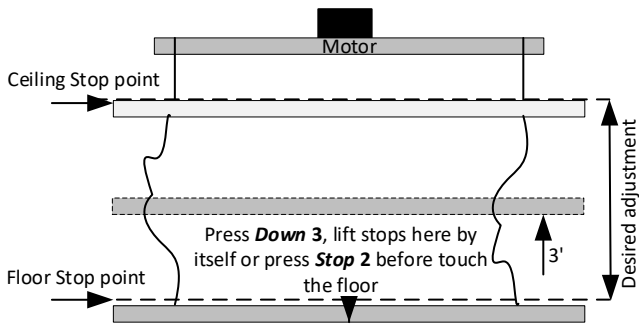

## Floor Adjustment Preparation (too low)

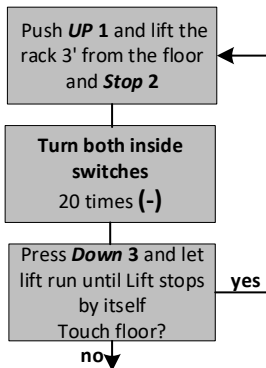

### Floor Adjustment (Page 25)

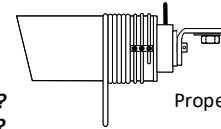
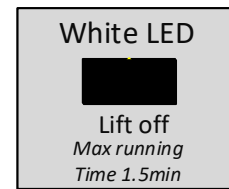
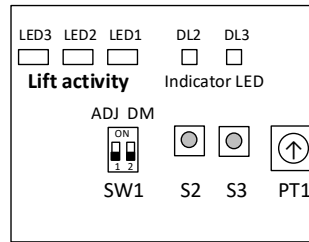

Proper coiled wire rope

Overheated? No running only clicking?  
Motors were running more than 4min?  
Allow motors to cool for 20min

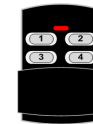

- 1 UP
- 2 Stop
- 3 Down
- 4 Learn

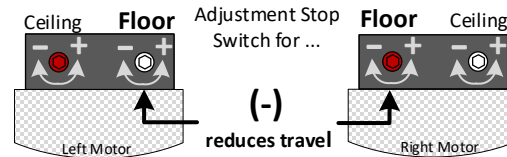

Turn righty tighty

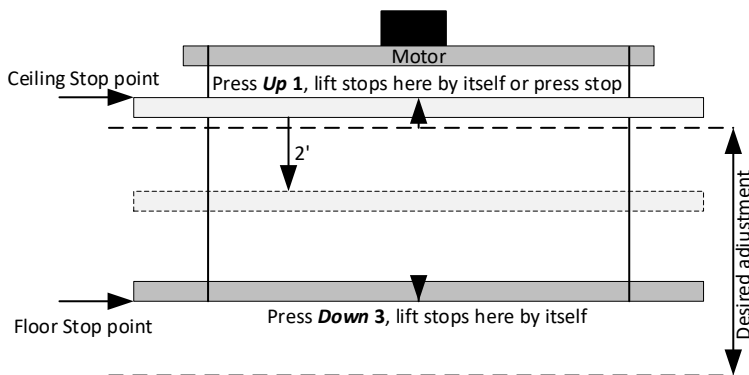
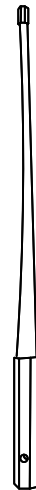

## Ceiling Adjustment Preparation (too high)

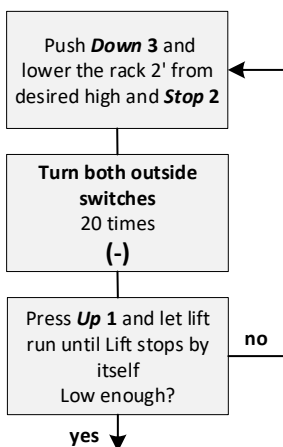

### Ceiling Adjustment (Page 25)

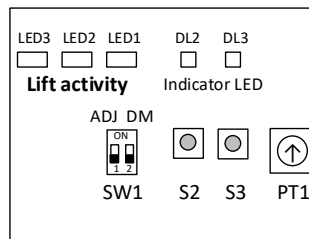

Overheated? No running only clicking?  
Motors were running more than 4min?  
Allow motors to cool for 20min

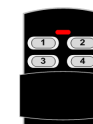
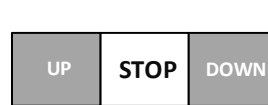

- 1 UP
- 2 Stop
- 3 Down
- 4 Learn

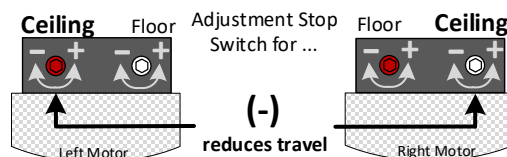

Turn righty tighty

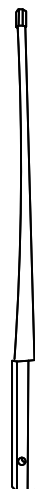

# 15

Strut Cover

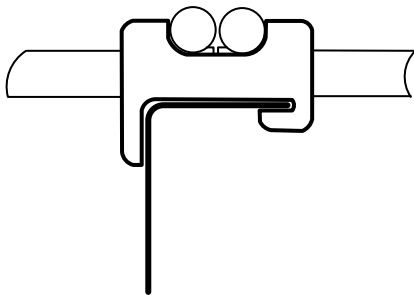
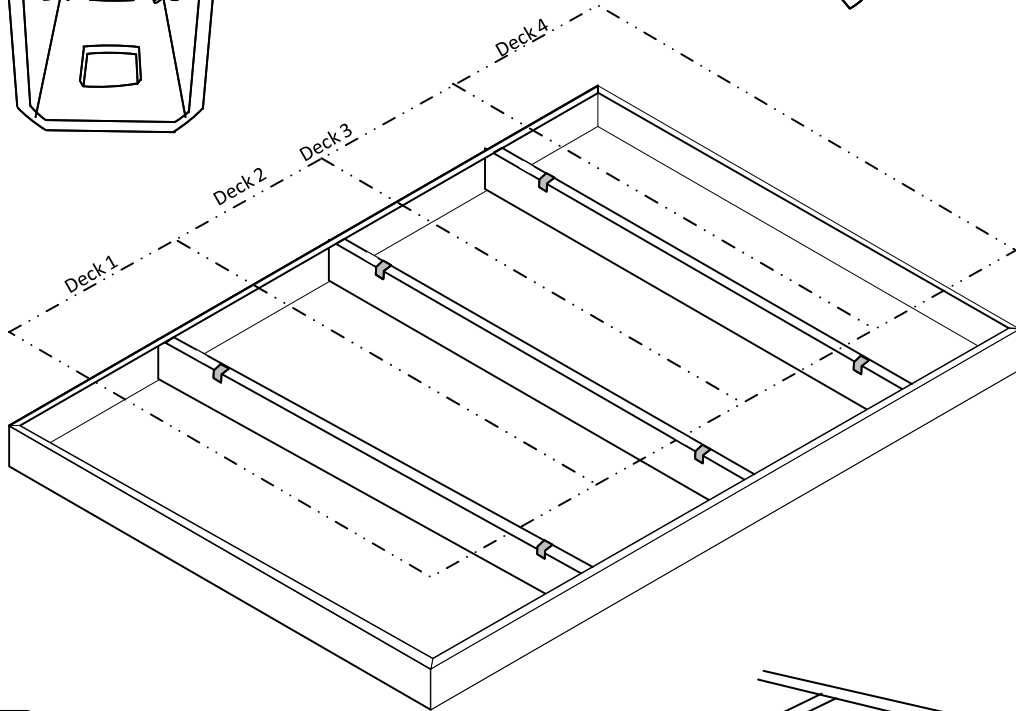
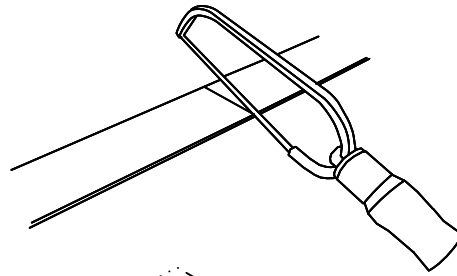
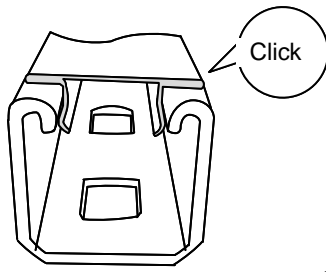
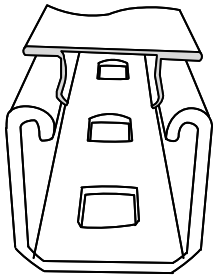
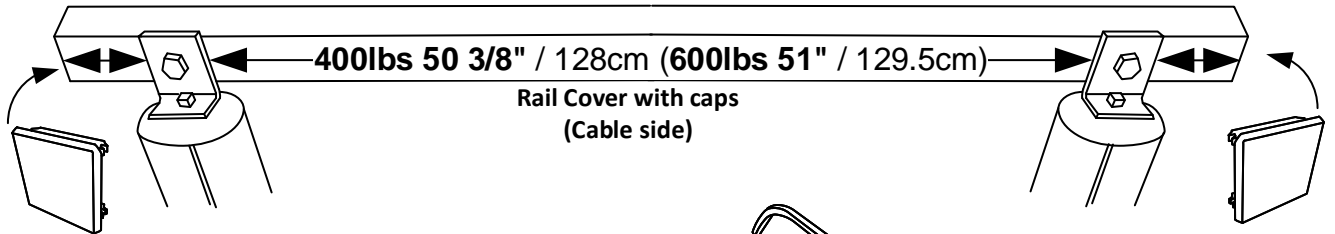
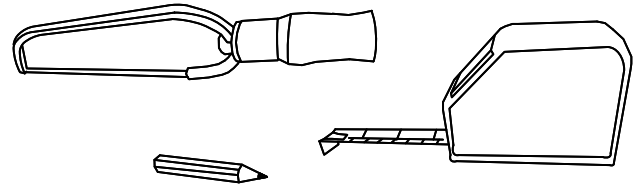
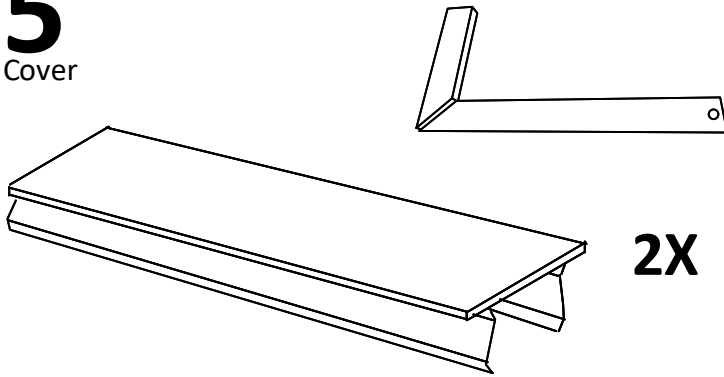

Support  
beam

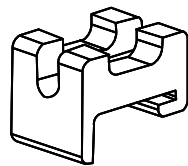

6x

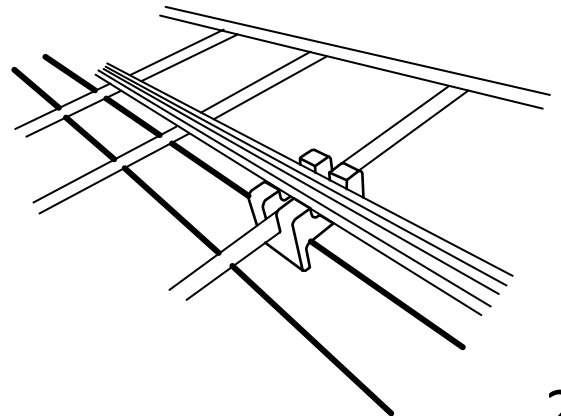

# 16 Inspection

Inspect and tighten all screws, wire clips, grommets and cotter pins. Make an alignment mark on each part that might be able to shift over time (like the motor mounts) using a Sharpie pen. Inspect all items, especially movement on the alignment marks, once a year.

Gap not more than  $1/16"$  / 1mm

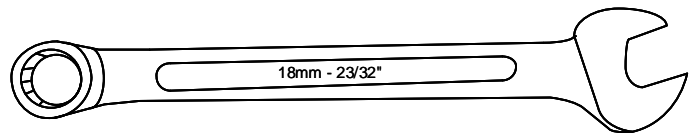
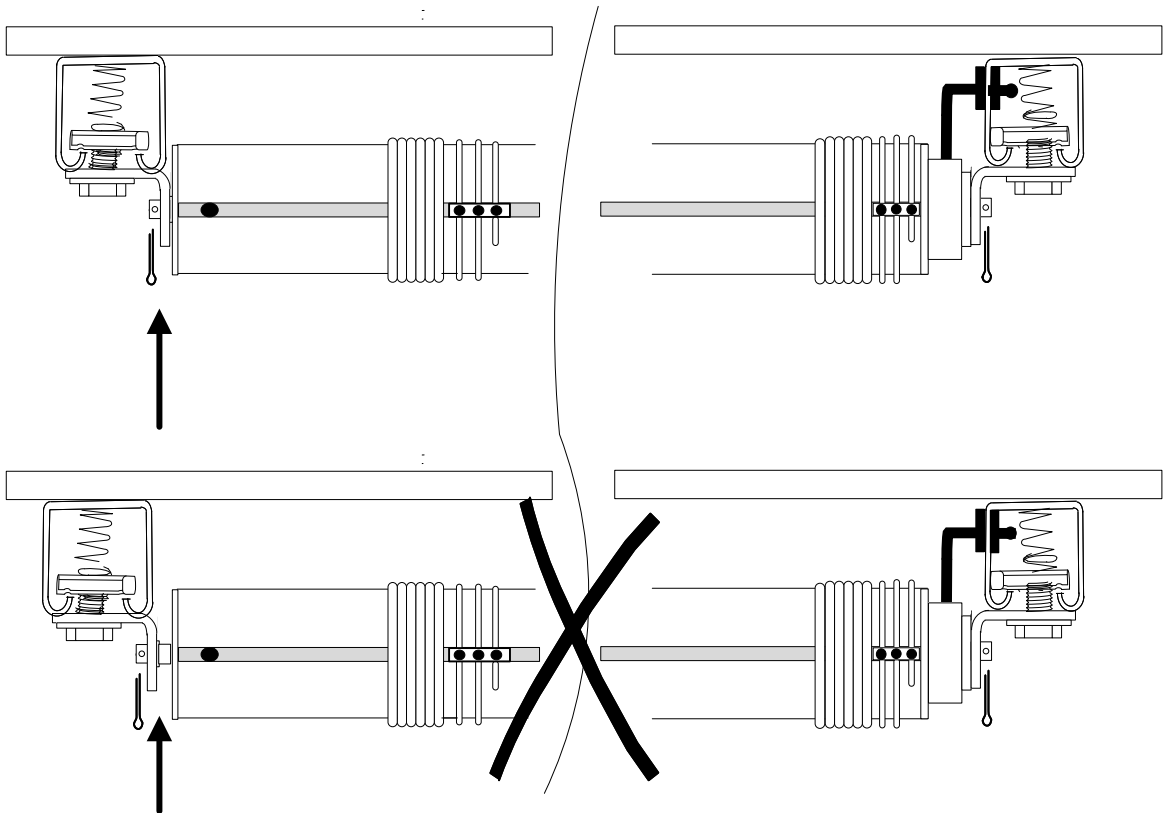

tighten

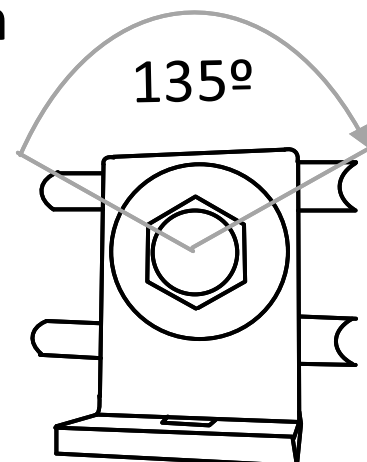
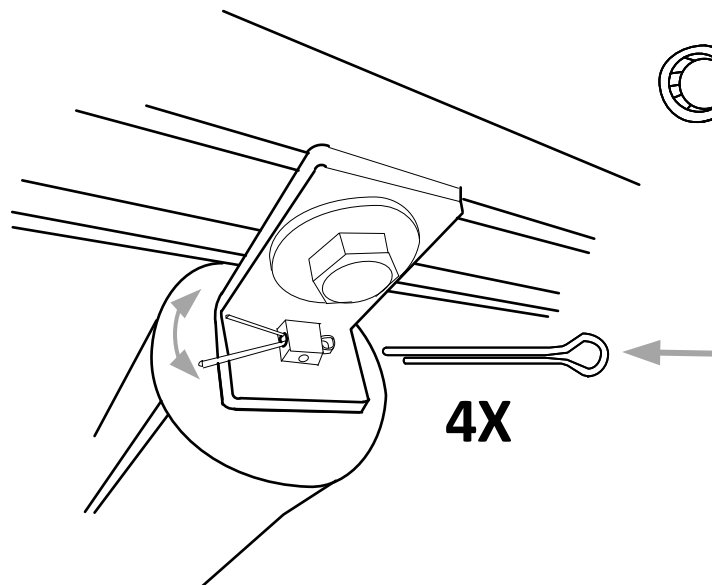

# 17 Check

## Check list (after installing, and than ones the year!

1. Lag screws tighten 8X
2. Cotter Pins installed and curved up 4X
3. 12mm Bracket screws tighten 4X
4. All set screws tighten 24X
5. All 6mm screws tighten 28X
6. Wire clips tighten 8X
7. E-Wire in the right order installed 11X
8. E-Wire is not laying on sharp corners
9. Controller is switch on
10. All set screws tighten 8x

*Please inspect all items and make a check mark!*

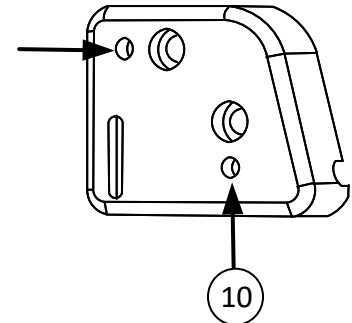
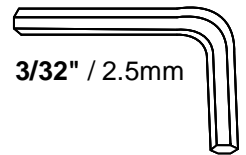
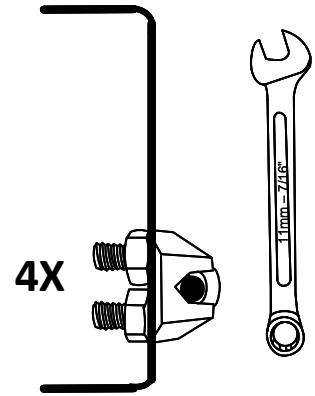
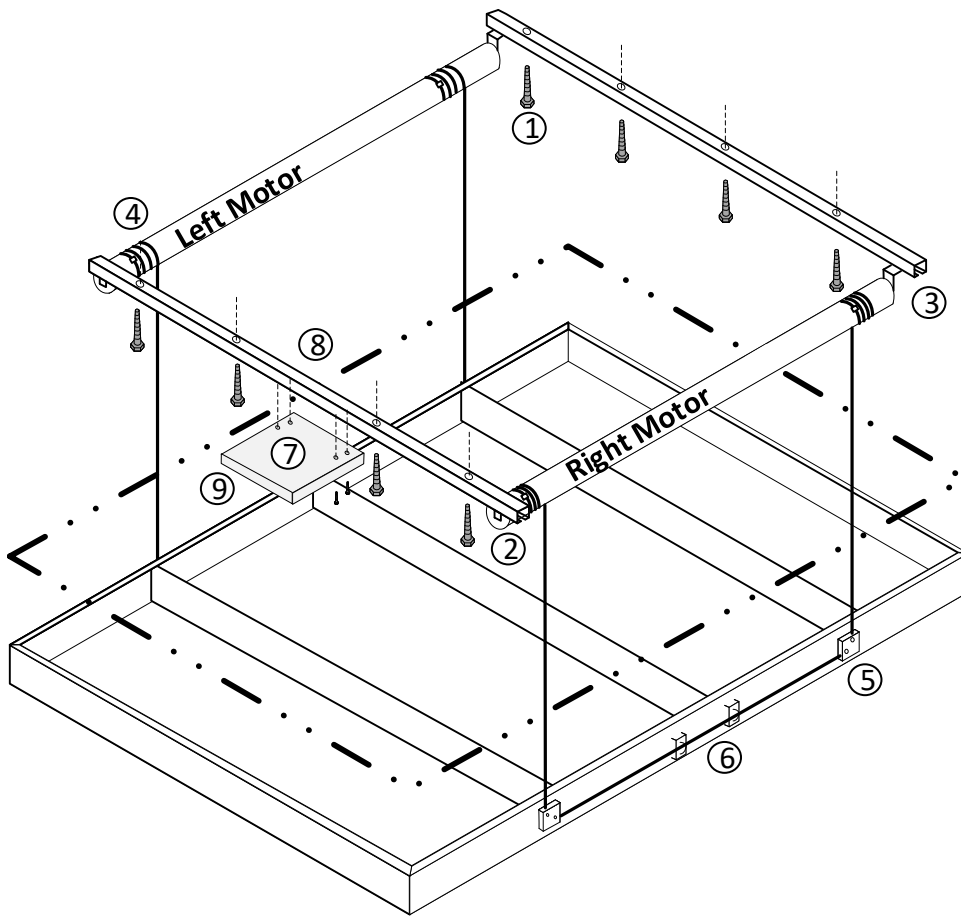

**After adjustment  
you MUST switch  
back on the other  
position!  
(DeadMan = ON)  
It's for your safety!**

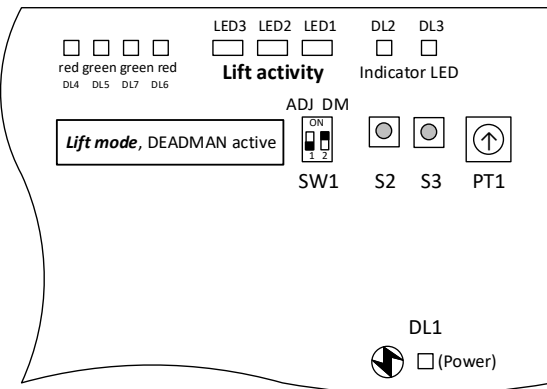



# Basic setting ( You can do it in each lift position!)

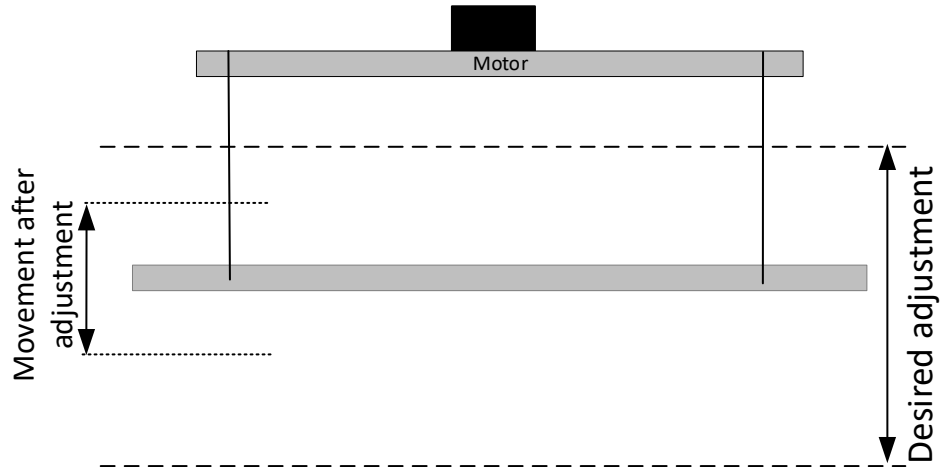

Switch ADJ on

Is the indicator LEDs on?  
If one of the LEDs is off: Turn motor switch lefty loosy (+) until the LED is switched on. Please see the diagram to the right.

All LEDs indicators are on?  
If not, please control the electrical wiring and the connectors. Make sure all screws are tight. Control cable for mechanical damage.

All LEDs indicators are on?  
Turn all switches righty tightly (-) until all LED's off.  
Stop turning when the LED switch is off!

Turn all switches e.g. 10-30 times lefty loosy (+)  
Are all LEDs on now?

If all LEDs are on  
Please switch ADJ and Deadman (DM) off and start with the adjustment

Left Motor  
(Green cable Ties)

Right Motor  
(Red cable ties)

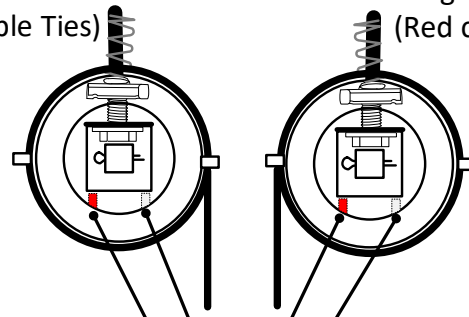

**Left Motor, green cable ties**  
DL4= Outside switch Ceiling adj.  
DL5=Inside switch Floor adj.  
**Right Motor, red cable ties**  
DL7=Inside switch Floor adj.  
DL6=Outside switch Ceiling adj.

*Lift doesn't work in this mode, only control and pre adjustment!*

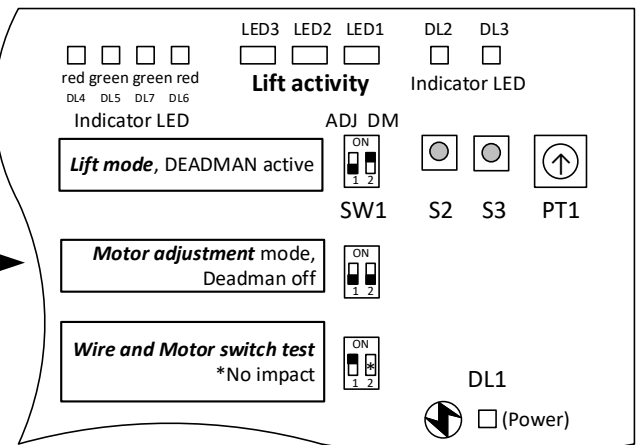
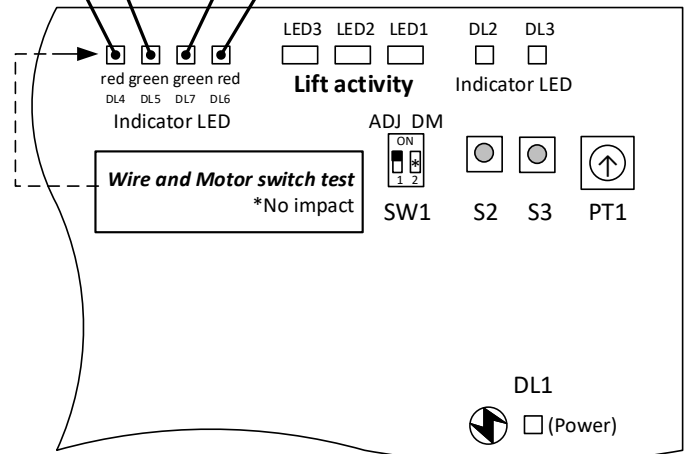



Running Time Preadjusted  
for 1.5 min

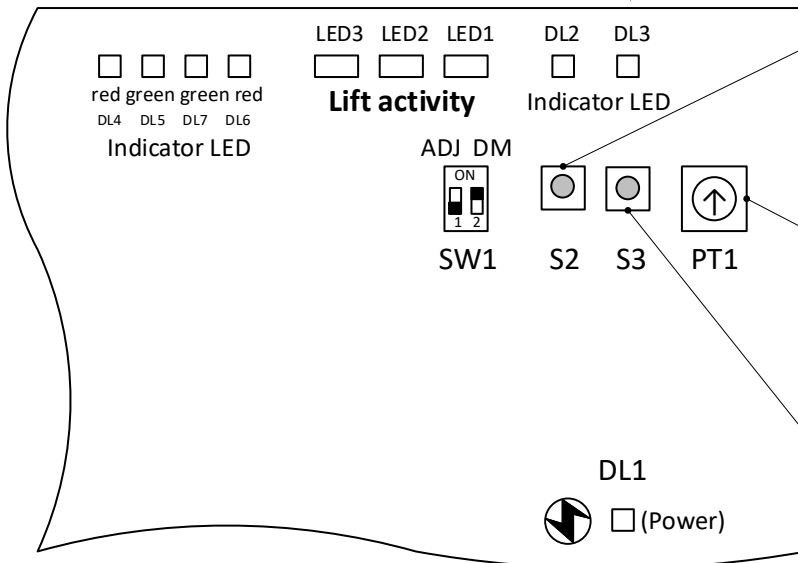

**S2**  
Remote learn button

**PT1**  
Delay time Default 5

**S3**  
Controller running  
time learn button  
10sec-1.5min

Switch on Controller	Indicator
Switch on the Controller, press power switch to the left	LED DL1 is lit
Programming the running time	Indicator
Press S3 run time button	LED DL3 starts to flash after 3 sec.
Hold S3 for 1:30min (max running time)	LED DL3 flashed and stopped release key
(You can program time between 10s and 1:30min) release key	e.g press S3, LED start to flash, hold for 30s, Running time is 30s now

Problems	Check
After switch on, LED DL1 is not lit	Is the plug connected to the outlet? Is the Outlet on a switch (and turned off)? Check the outlet works with an appliance. Check the wire connection. Disconnect the Controller from the outlet and check the fuses.

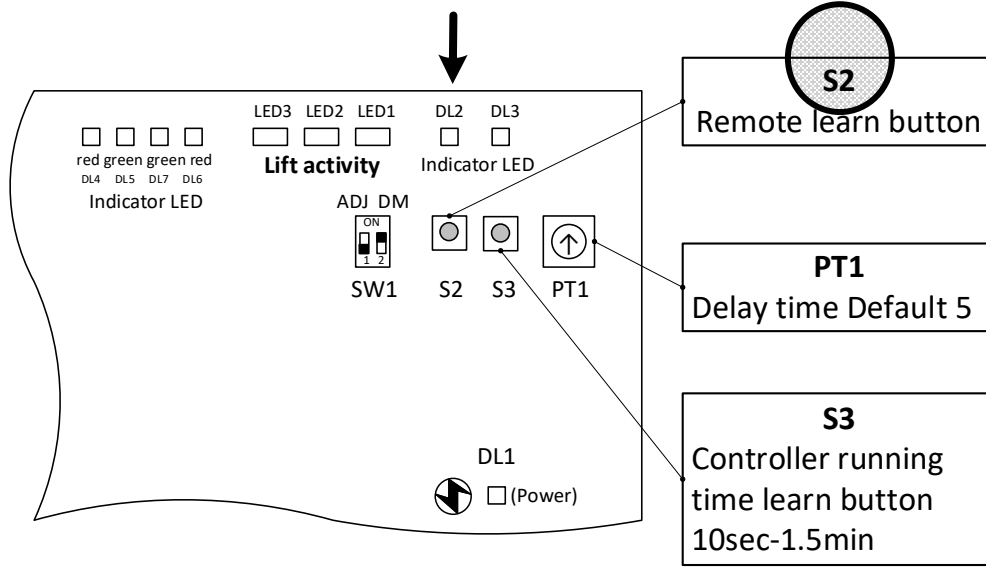

- 1 UP
- 2 Stop
- 3 Down
- 4 Learn

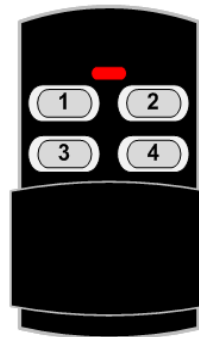

**One Channel Remotes are Pre-configured**

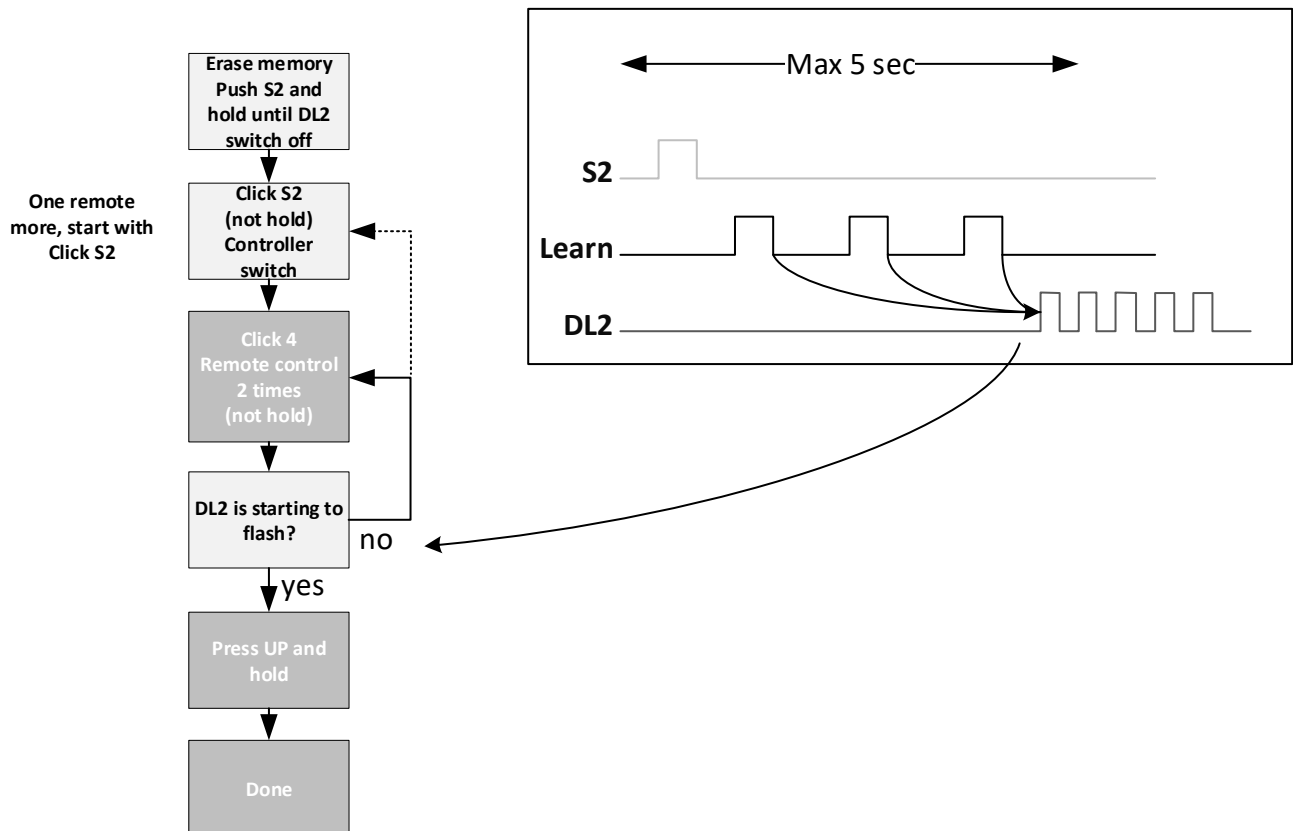





**Overheated? Not running just clicking?  
Motors were running more than 4min?  
Allow motors to cool for 20min**

**Clicking**

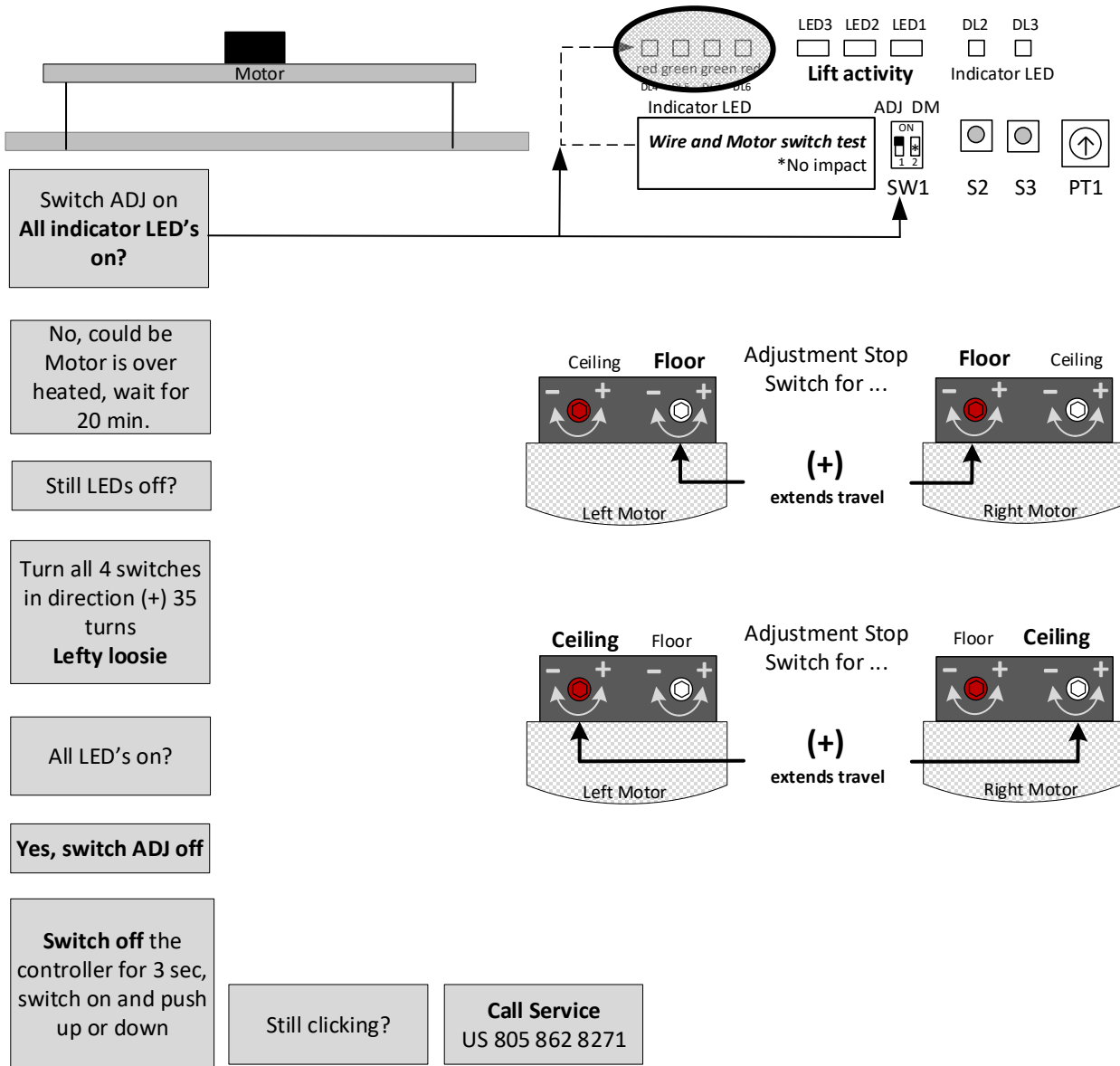

**If you are done with the adjustment, please switch the DeadMan function back on**

**Important! The Lift has to run to the ceiling end points (stopped automatically) in order to be leveled properly.**

