

SOHAMO
OWNERS MANUAL

V 1.1 | 2023
sohamo.com

TABLE OF CONTENTS

Table of Contents	2
WARNING	4
Unboxing	6
What's in the Box	6
Frame Number and Motor Number	7
EBike Structure Introduction	7
Installation of Integral Body	8
Fold Your Bike Up	13
How to Take Out and Put in the Battery	14
How to Adjust the Seat Height	15
How to Adjust the Height of the Handlebar	15
How to Charge	16
Instrument Introduction	17
On/Off Meter	17
Increase/Decrease the PAS Level (Pedal-Assist)	18
Advanced Menu [Speed Limiter]	19
Optional Readout Display Menu	20
Lighting System	20
Safety Notes	21
OPERATING SAFETY	21
Helmets and Local Laws	21
Pre-ride Safety Check and Inspection	21
Riding in Wet Conditions	21
Riding at Night	22
Max Weight	22
PRE-RIDE SAFETY CHECK	22
WARRANTY	24
Electric Bike Maintenance	25
Regular cleaning	25

Lubrication	26
Checkthebolts	26
Tirepressure	26
Brake Pads	26
Waterproofing	26
Battery care	27
DISCLAIMER	27

WARNING!

Read this entire manual before assembling or using your new electric bike. Do not modify, disassemble, or replace the original electrical components on your bike. Doing so will invalidate your warranty and could put you in danger. Riding any type of bike comes with some risks which can't be predicted or avoided. Taking proper care of bike components can lower the risk of sudden failure of components but cannot prevent it. These sudden failures could cause serious harm, injury, or death to the rider. If you notice abnormalities in any component on the bike, take it to a licensed mechanic to be repaired or replaced immediately.

SOHAMO Inc assumes no liability for harm, injury, or death of the rider. This manual is not intended to function as a detailed service manual.

SOHAMO recommends having your local bike shop mechanic perform a detailed safety check of your bike before your first ride. Ensure your local mechanic is experienced and reputable. The S3 can withstand most rain showers without sustaining damage. The bike has an IP rating of 65. This means it is dust tight and can withstand jetting water. See the IP code for more details. It does not mean that the bike and its mechanical and electrical components are waterproof. We do not recommend storing or using the bike in excessively wet conditions. The warranty for the SOHAMO S3 does not cover water damage.

THANK YOU FOR YOUR PURCHASE!

We appreciate your purchase and we hope you thoroughly enjoy riding your E-Bike.

If you need any assistance or have any questions please feel free to contact us.

CONTACT INFORMATION

Email: support@sohamo.com

Website: sohamo.com

Phone: 001763-888-8694

UNBOXING

Congratulations on your purchase of a new SOHAMO E-Bike! Your bike and related accessories are inside your box, and the instructions below are meant to show you all the parts inside the box. Before removing the packing foam, please take out all the parts to confirm if there are any missing parts.

If any parts are missing or damaged, please contact G-Force customer service as soon as possible.

 **Note:** If you are installing or riding a bike for the first time, we recommend that you seek professional help, preferably from a certified bike mechanic.

What's in the box:

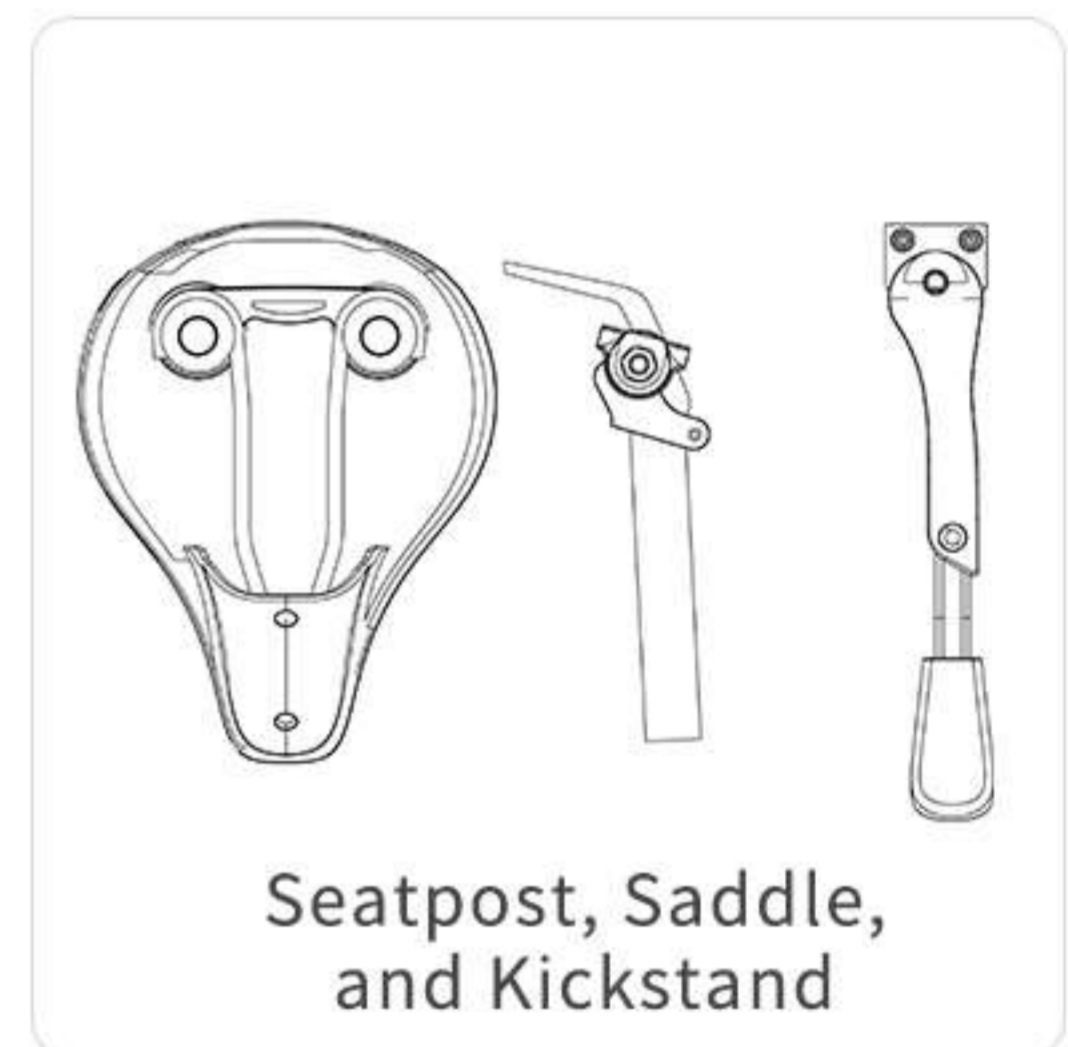
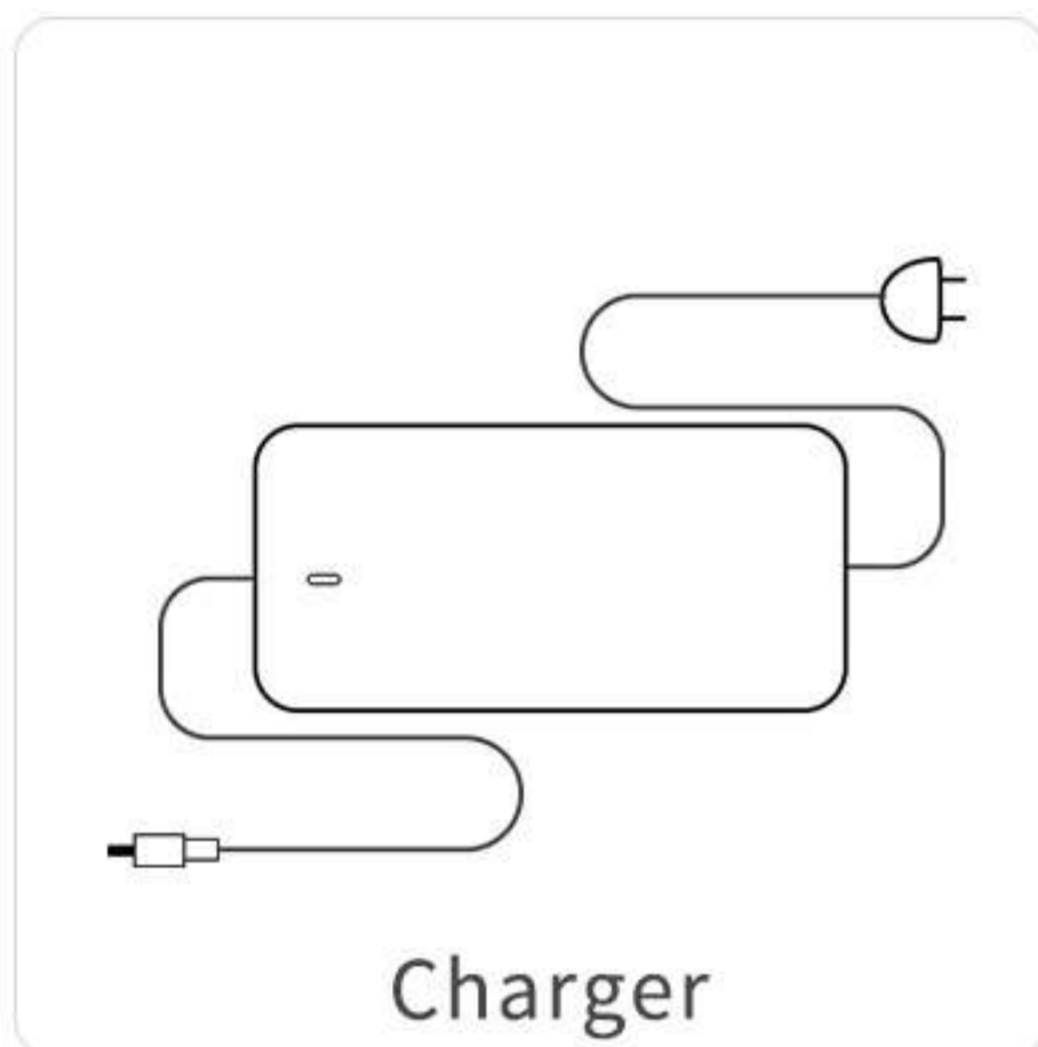
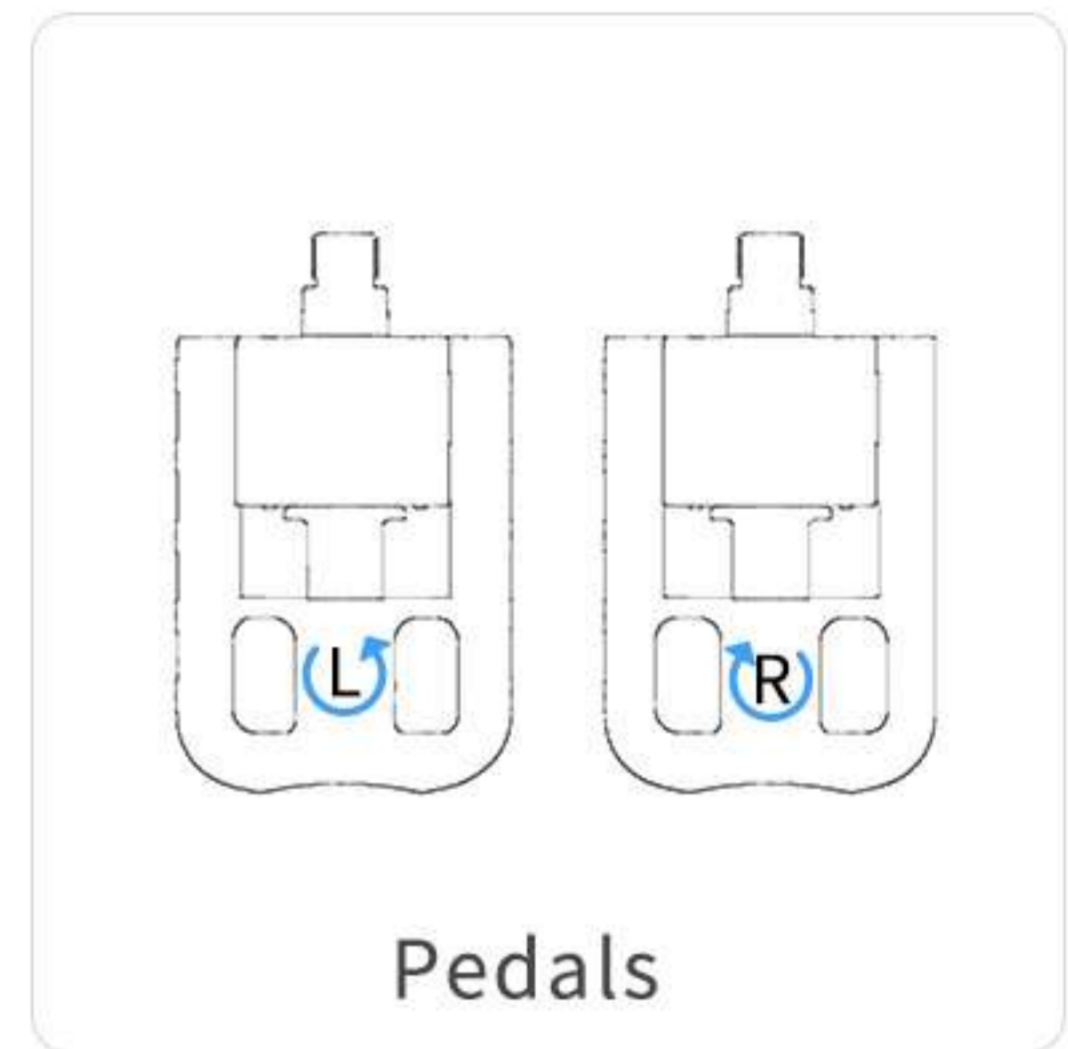

FRAME NUMBER AND MOTOR NUMBER

Your bike has two unique serial numbers on the frame and on the motor. As shown in the picture

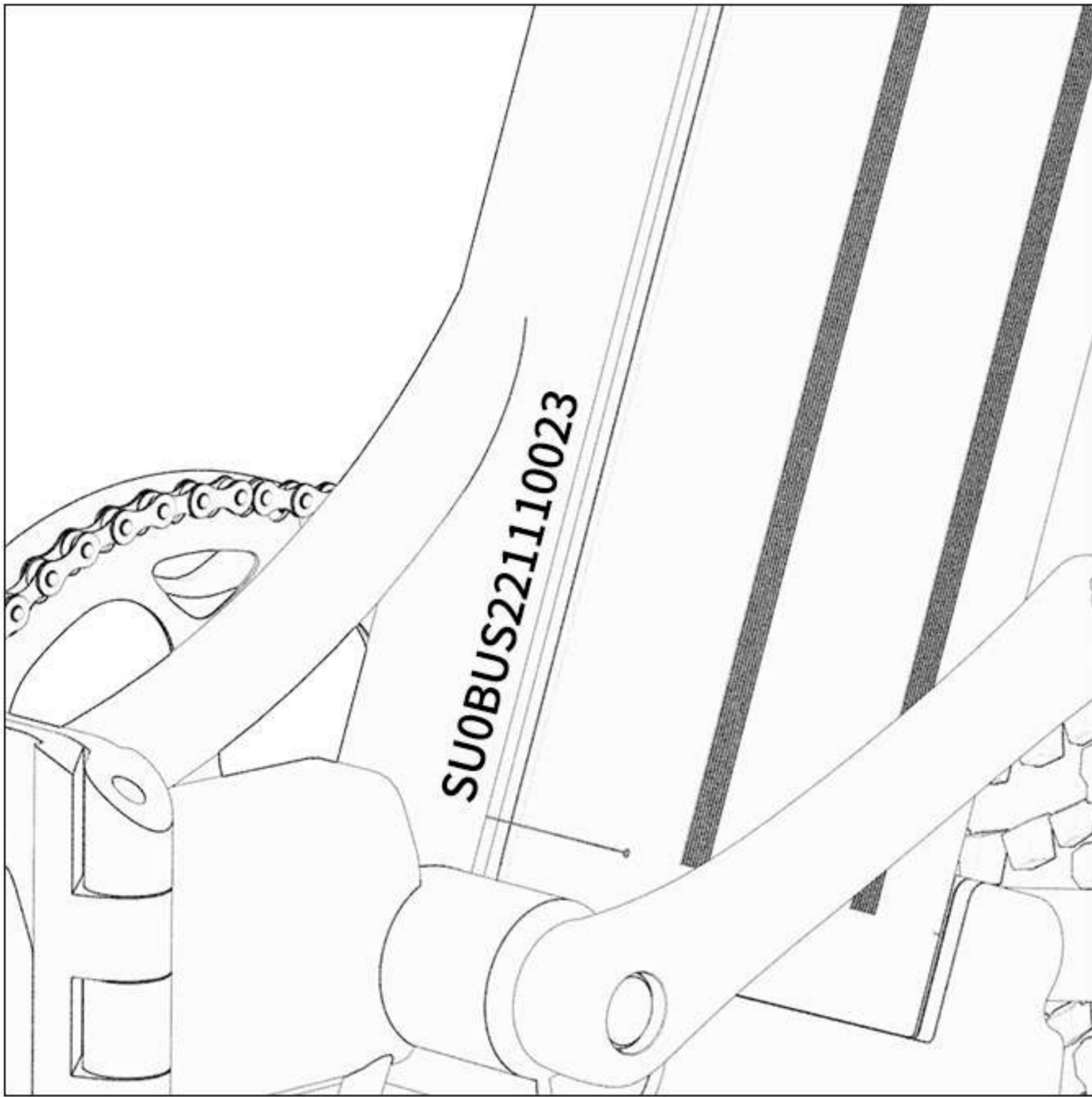

Please find the serial number and motor number on your bike and record them. The motor number and frame number will be the proof of the warranty.

Also, if your electric bike is stolen, you can provide the frame number for law enforcement.

EBIKE STRUCTURE INTRODUCTION

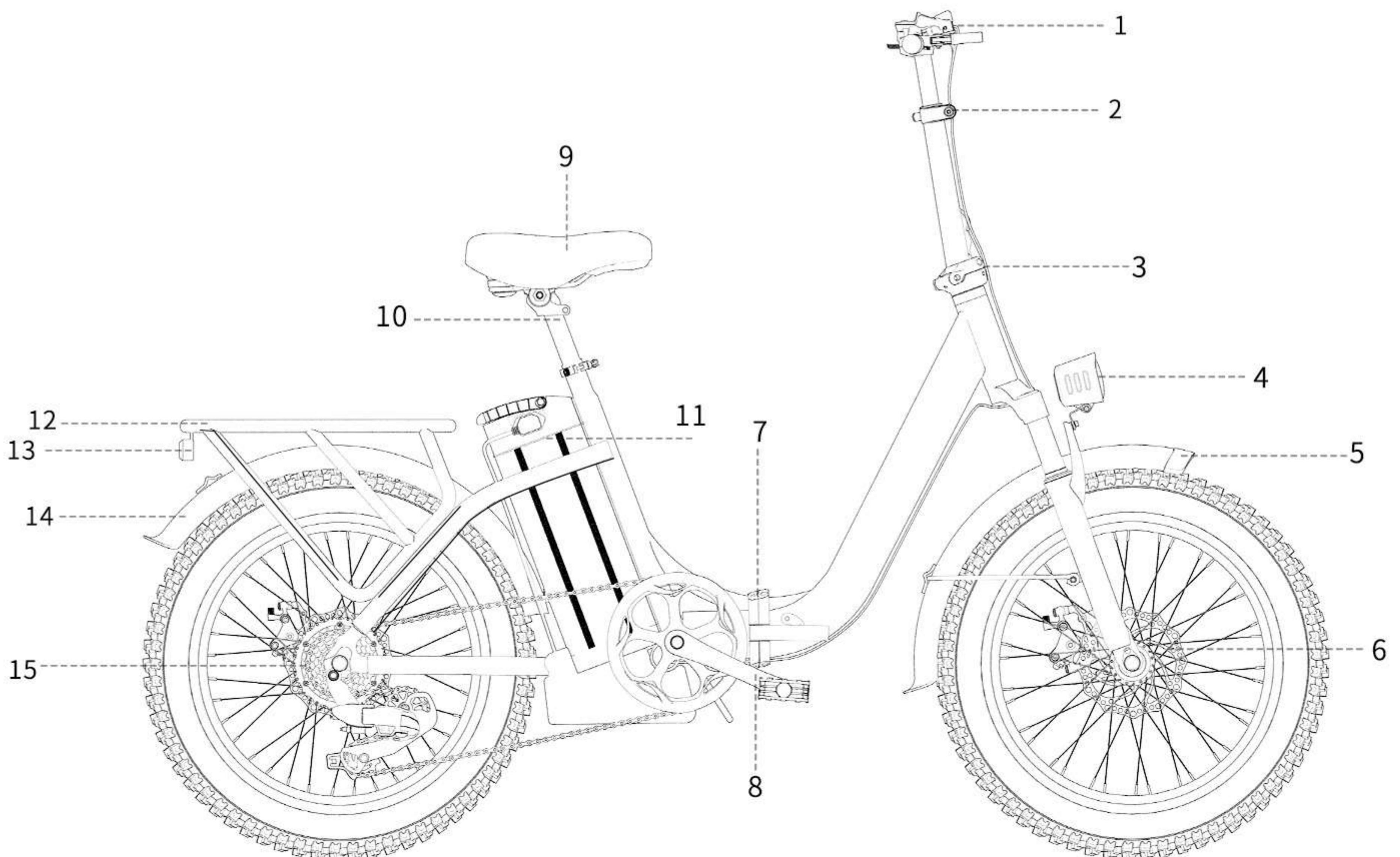

- | | | |
|----------------------------------|----------------------|-----------------|
| 1. Handlebar | 6. Brake disc | 11. Battery |
| 2. Handlebar quick-release lever | 7. Frame locking arm | 12. Rear rack |
| 3. Headset stem release lever | 8. Crank arm | 13. Reflector |
| 4. Headlight | 9. Saddle | 14. Rear fender |
| 5. Front fender | 10. Seatpost | 15. Motor |

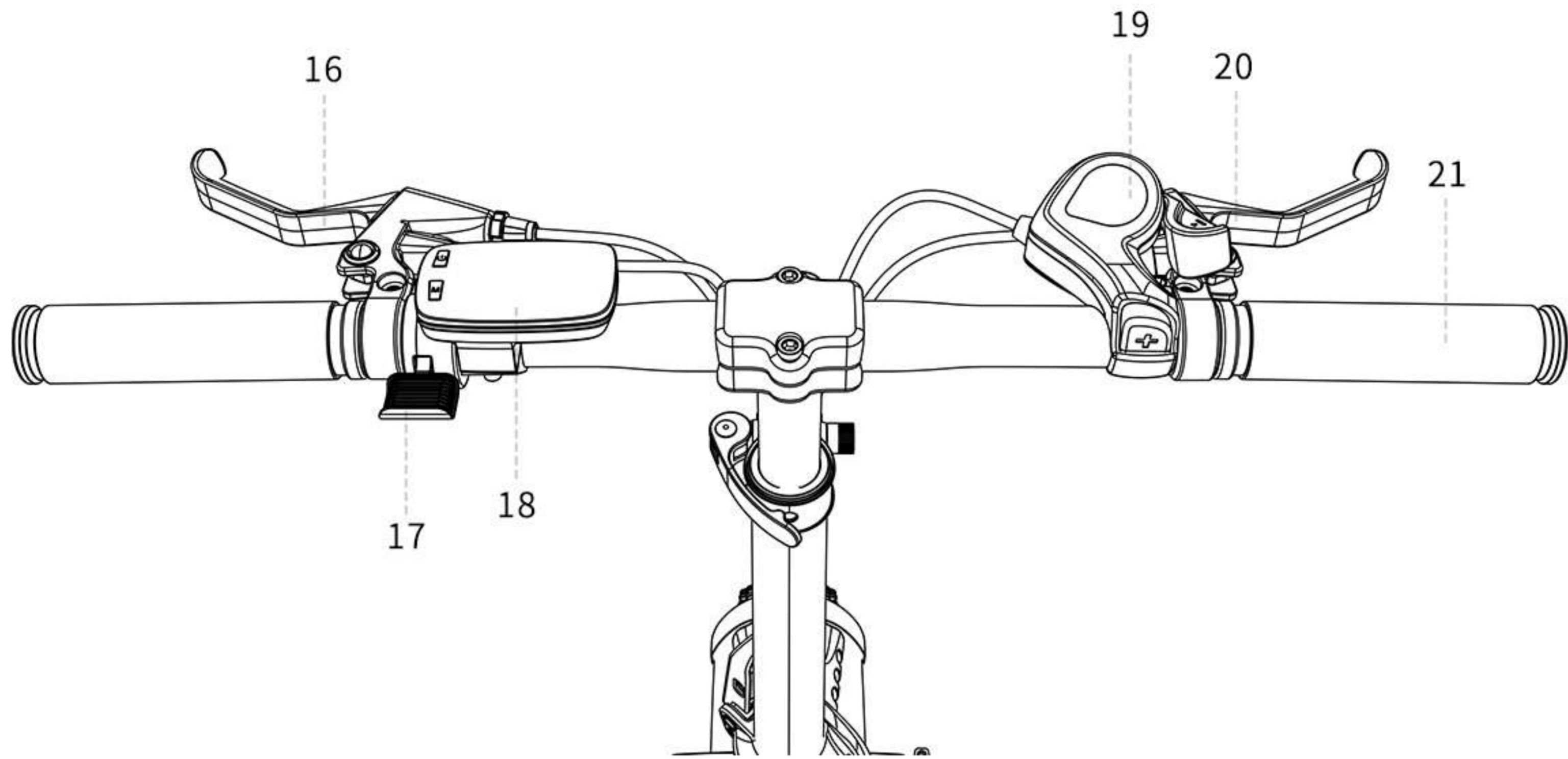

- | | | |
|-----------------------|-------------------|----------------------|
| 16. Front brake lever | 18. LED display | 20. Rear brake lever |
| 17. Thumb throttle | 19. Thumb shifter | 21. Handle |

INSTALLATION OF INTEGRAL BODY

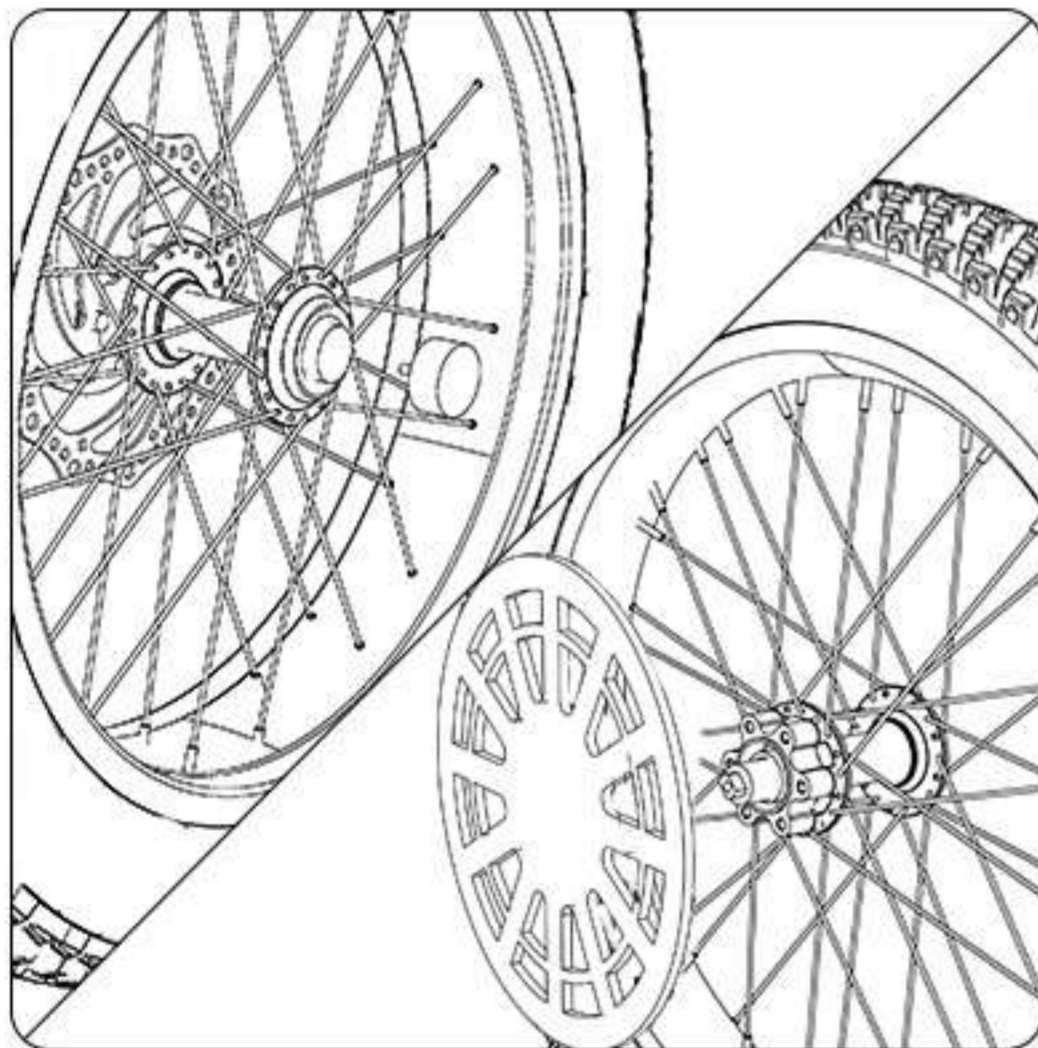

1. Remove the black dust cap and the plastic protector from the front wheel hub.

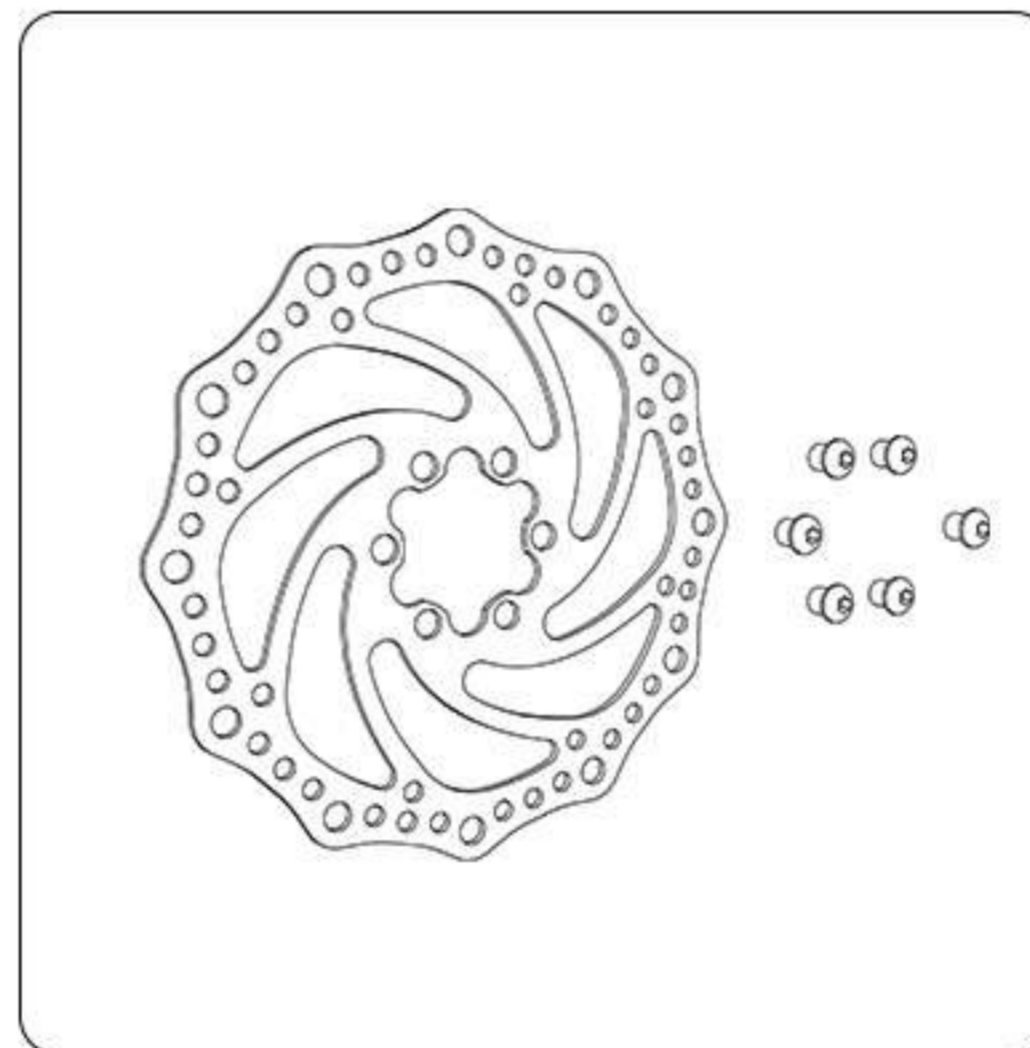

2. Find the rotor and its mounting hardware that came with your bike.

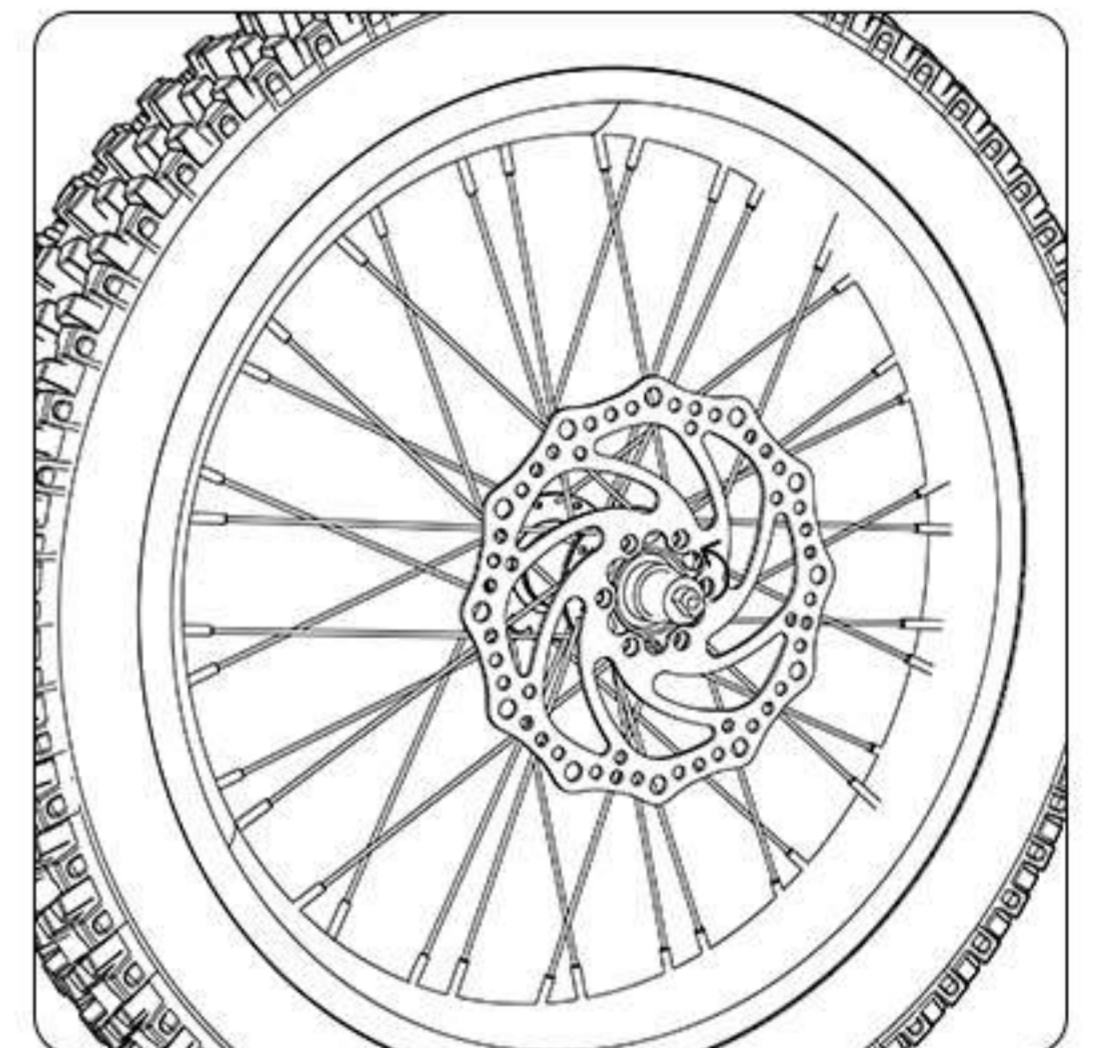

3. Find the rotor and its mounting hardware that came with your bike.

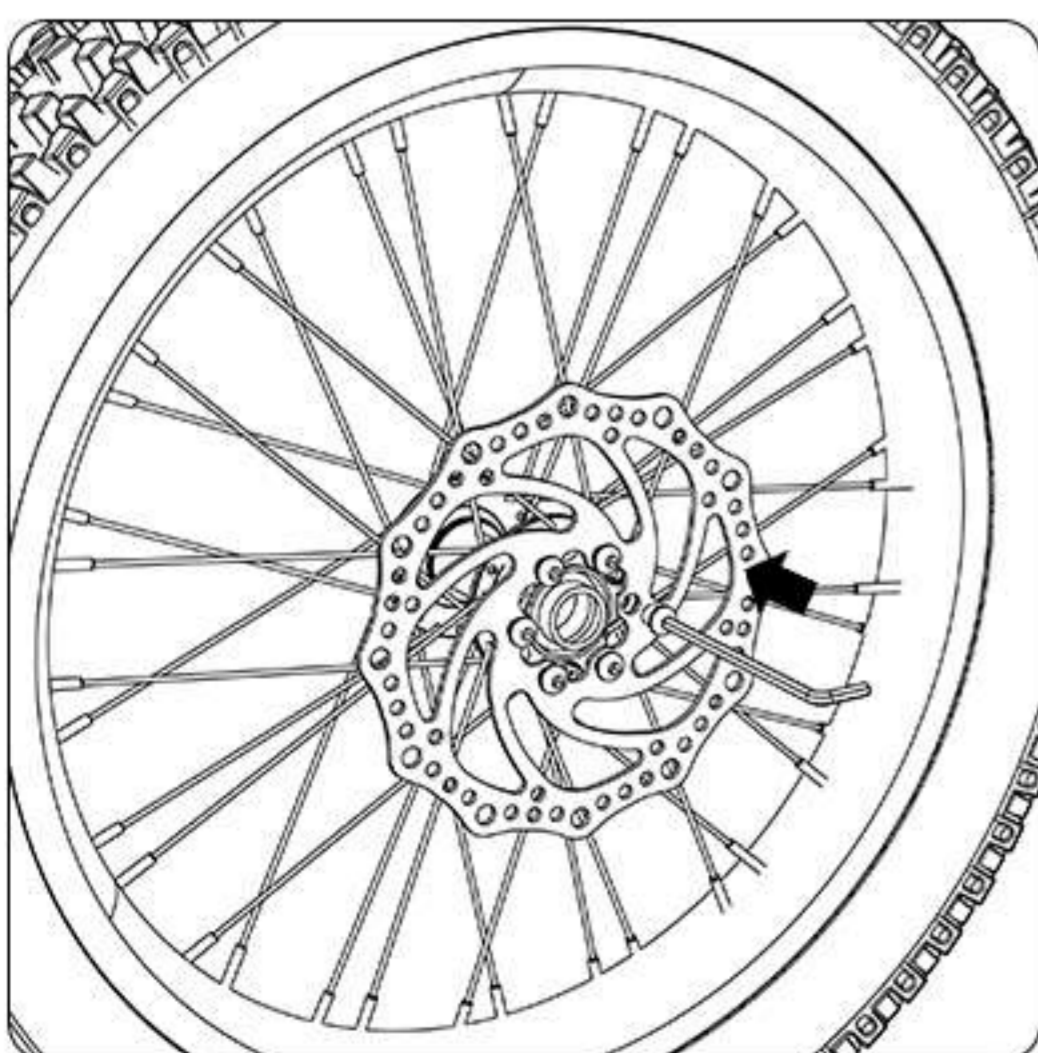

4. Use a 4mm Allen key to tighten every two bolts in a diagonal pattern.

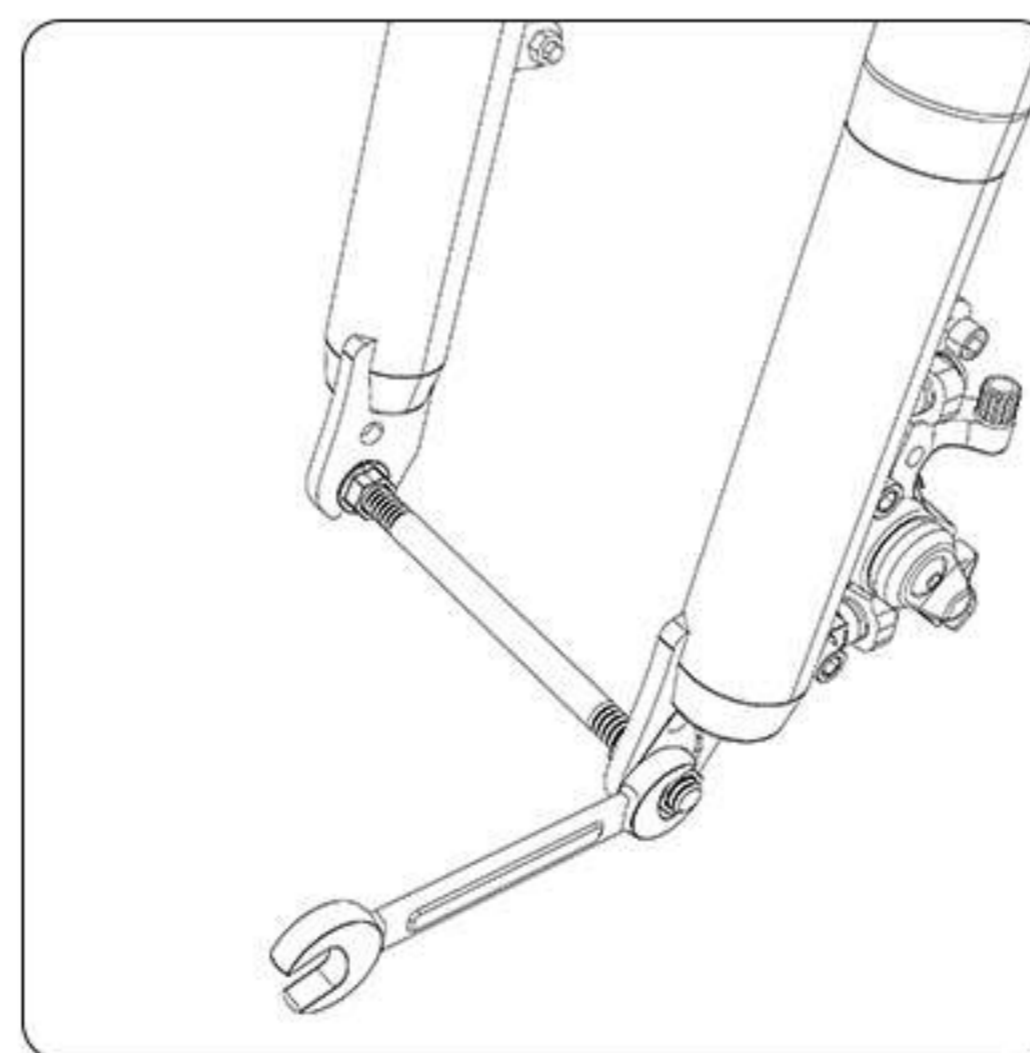

5. Take the fork dropout protector down by using a 18mm open-end wrench.

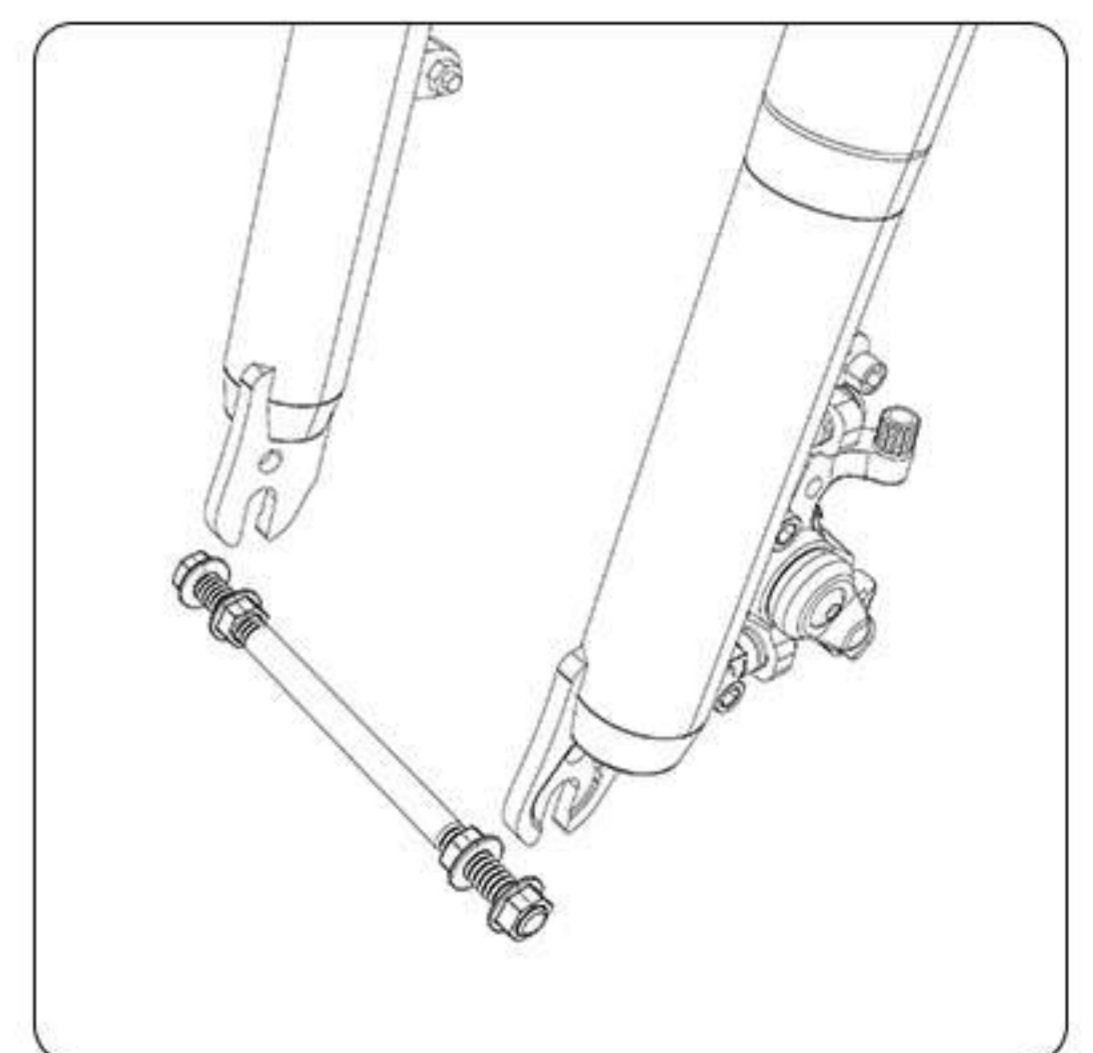

6. Tip: Thread in the two internal nuts toward the rod center and then unscrew the two external nuts outward.

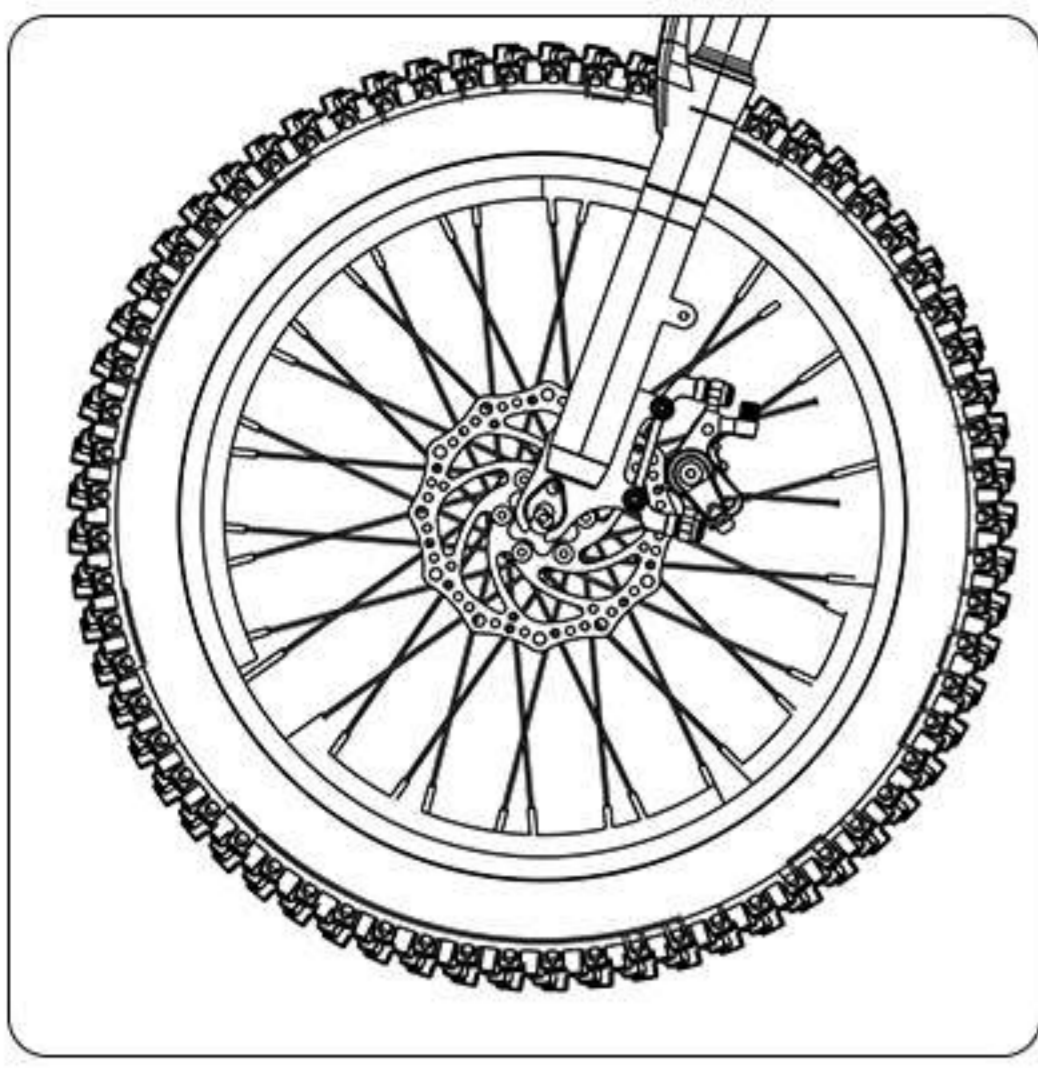

7. To install the front wheel, lift up the front of the bike carefully to place the C-shape dropouts of the fork onto the wheel axle.

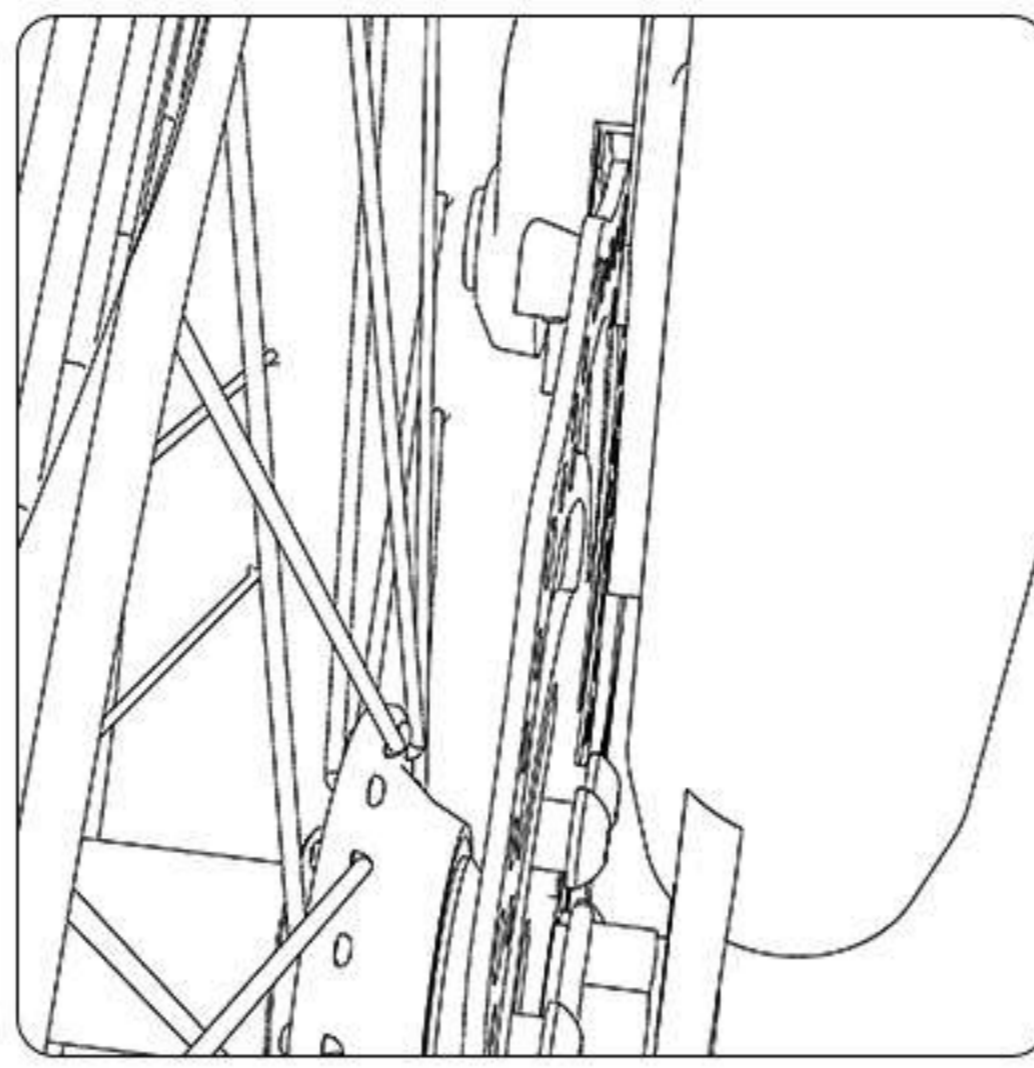

8. Take a look at the brake rotor and make sure that the rotor slides through in between the brake pads inside the caliper.

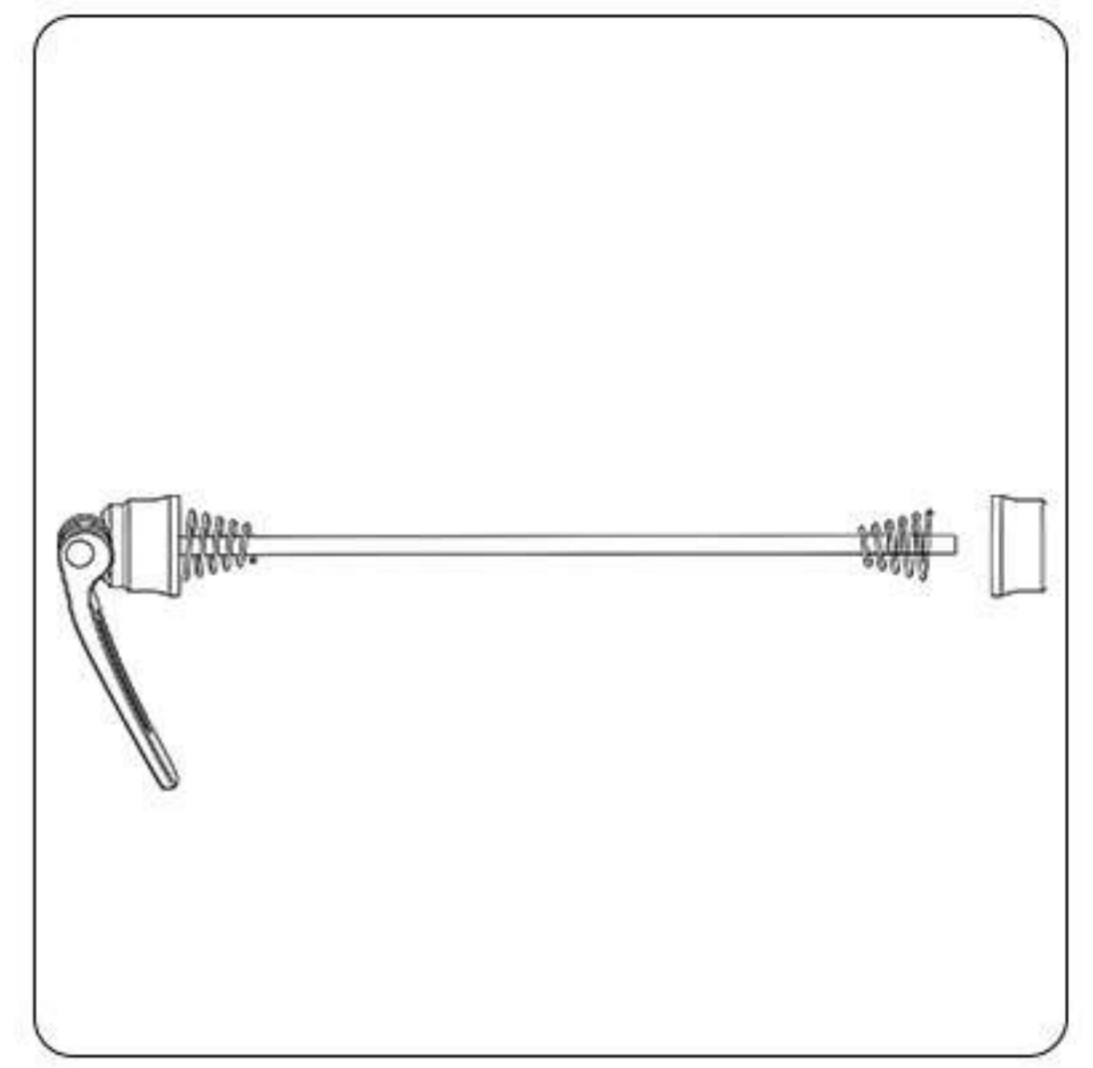

9. To install the quick-release skewer, unscrew the nut from one side to remove one conical spring.

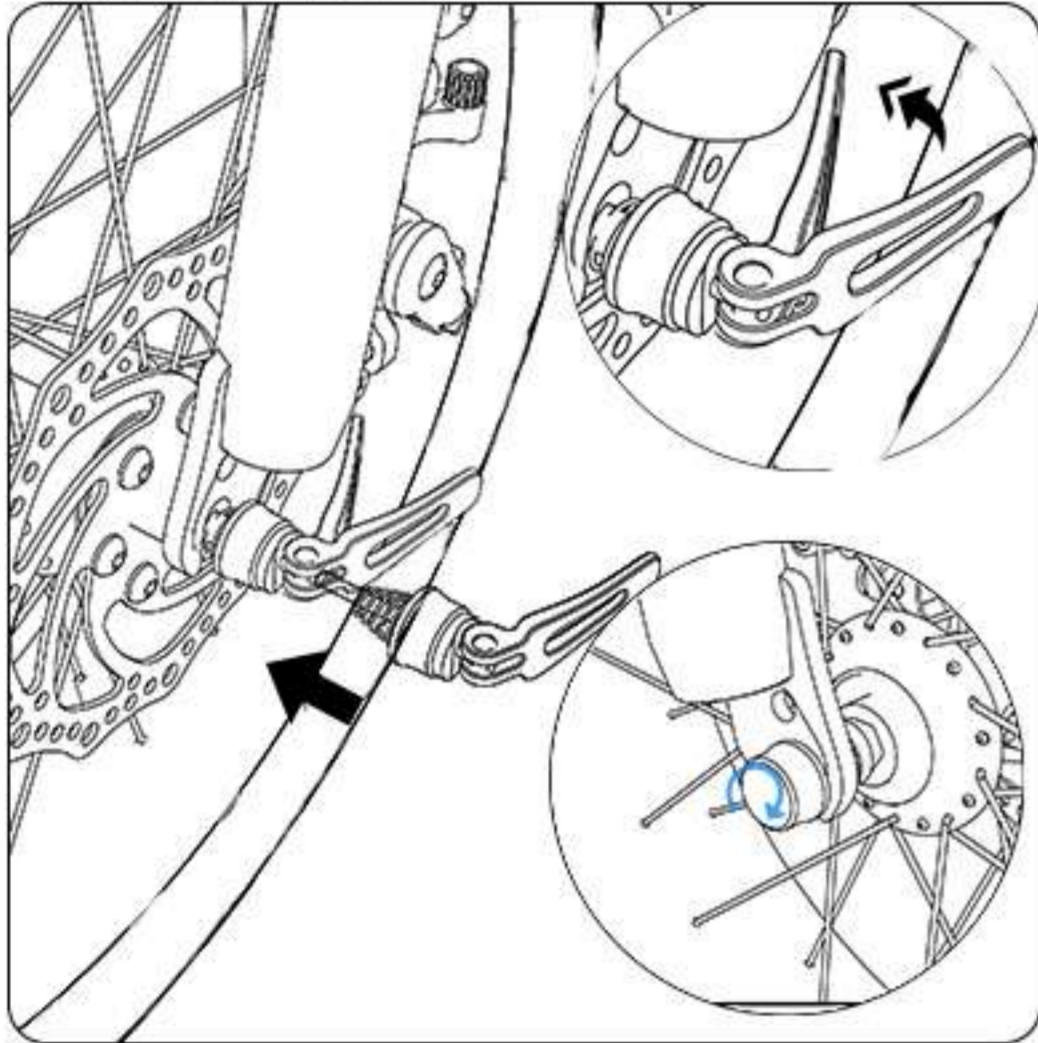

10. Install the conical spring with the narrow point in and then screw in the nut. Then properly close quick-release skewer lever.

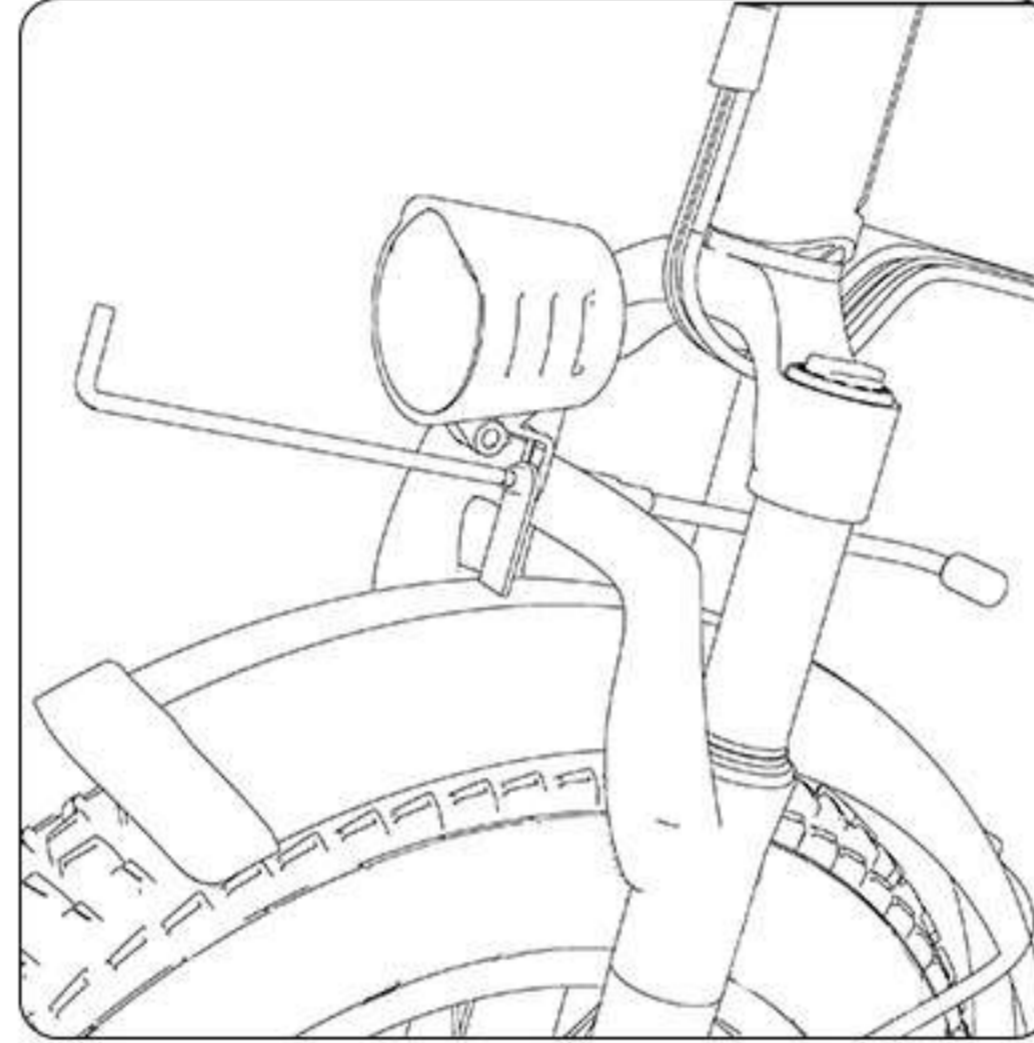

11. Pass the bolt through the headlight bracket, then through the L-shaped mounting bracket on the fender, and then attach them to the mounting hole on the top of the fork.

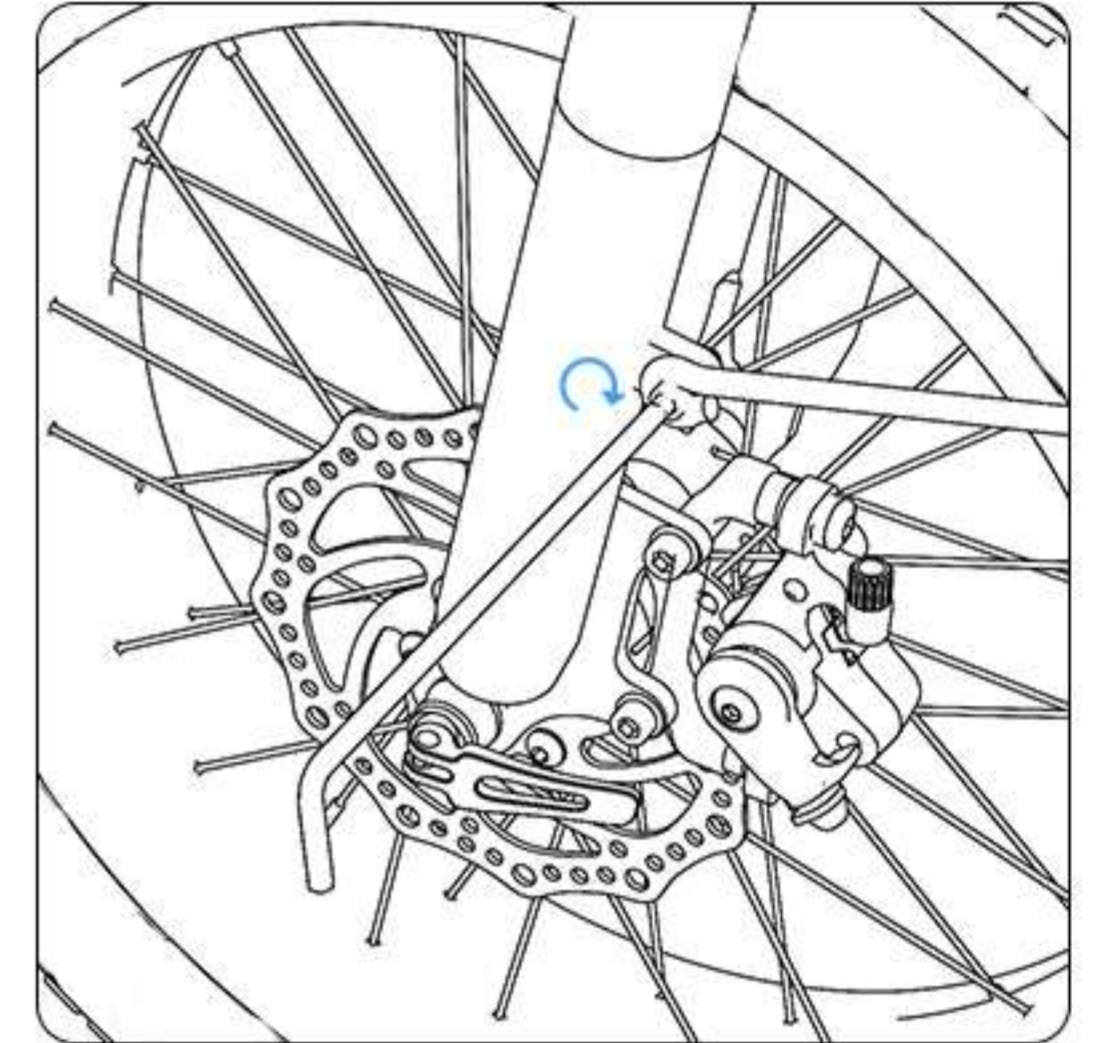

12. Pass the bolts through the steel spacer, then fender arm eyelets, and use the 5mm Allen key to thread in the bolt to attach the fender braces onto the bike.

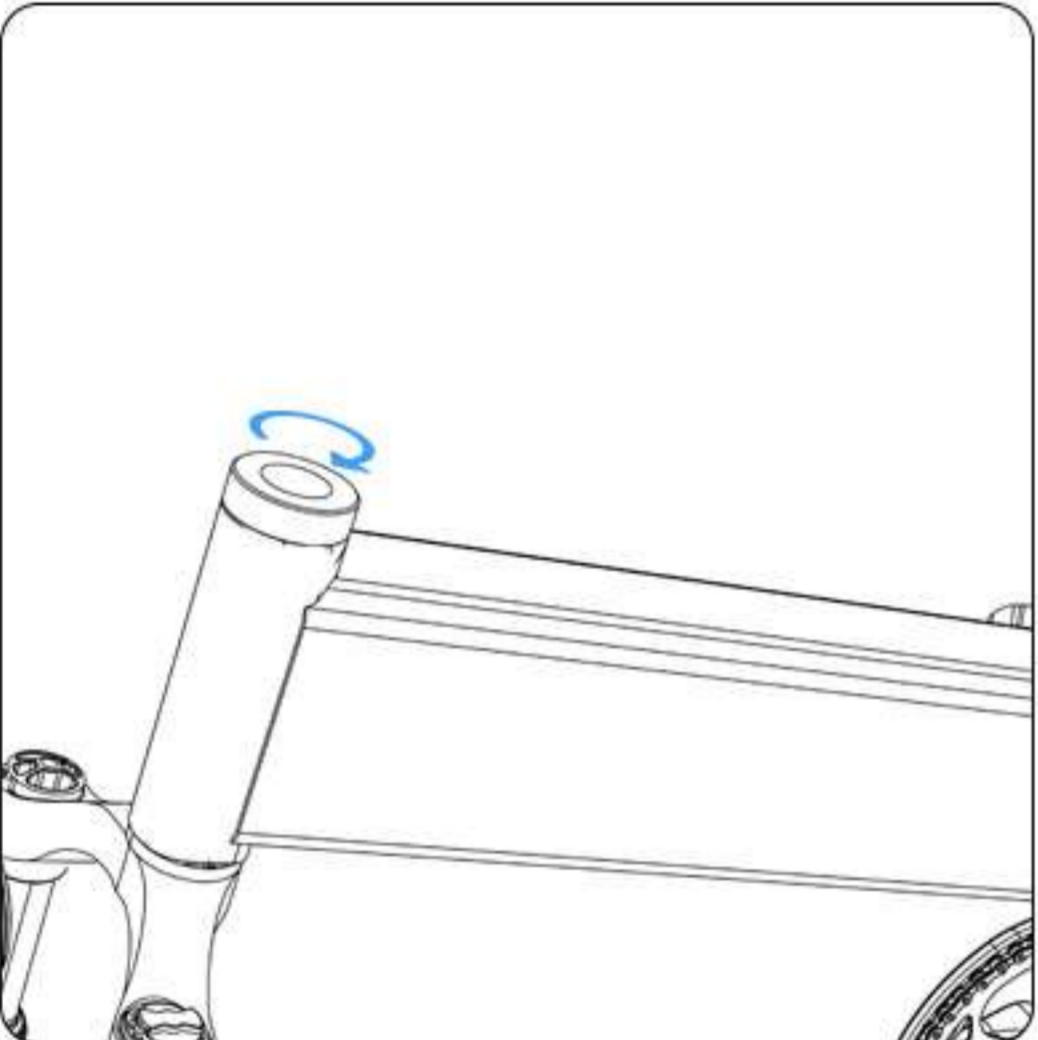

13. Tighten the headset cup by hand. Note that a loose headset might lead to a rattling noise during riding.

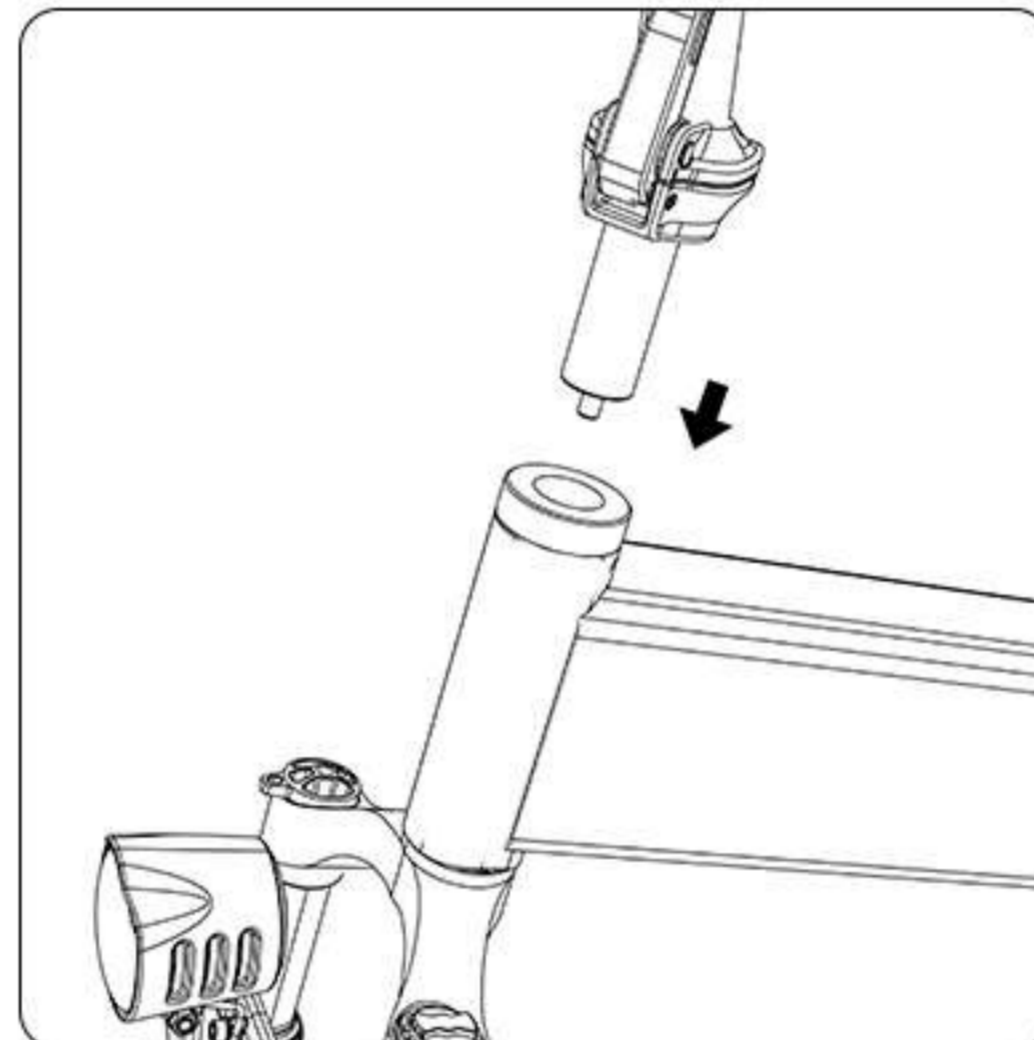

14. Locate the folding headset stem and slide it directly onto the head tube.

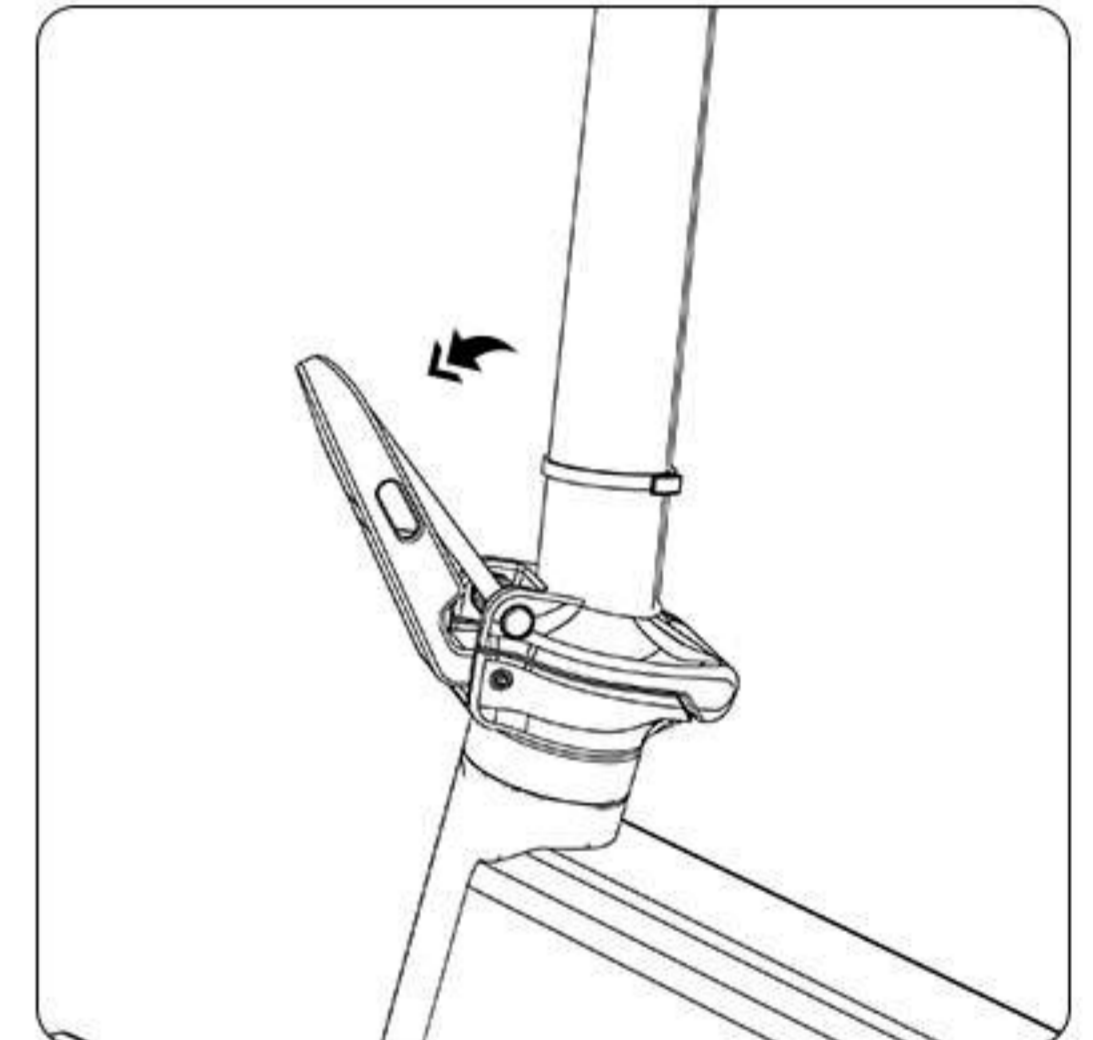

15. Tweak the safety collar to undo the stem hinge release lever.

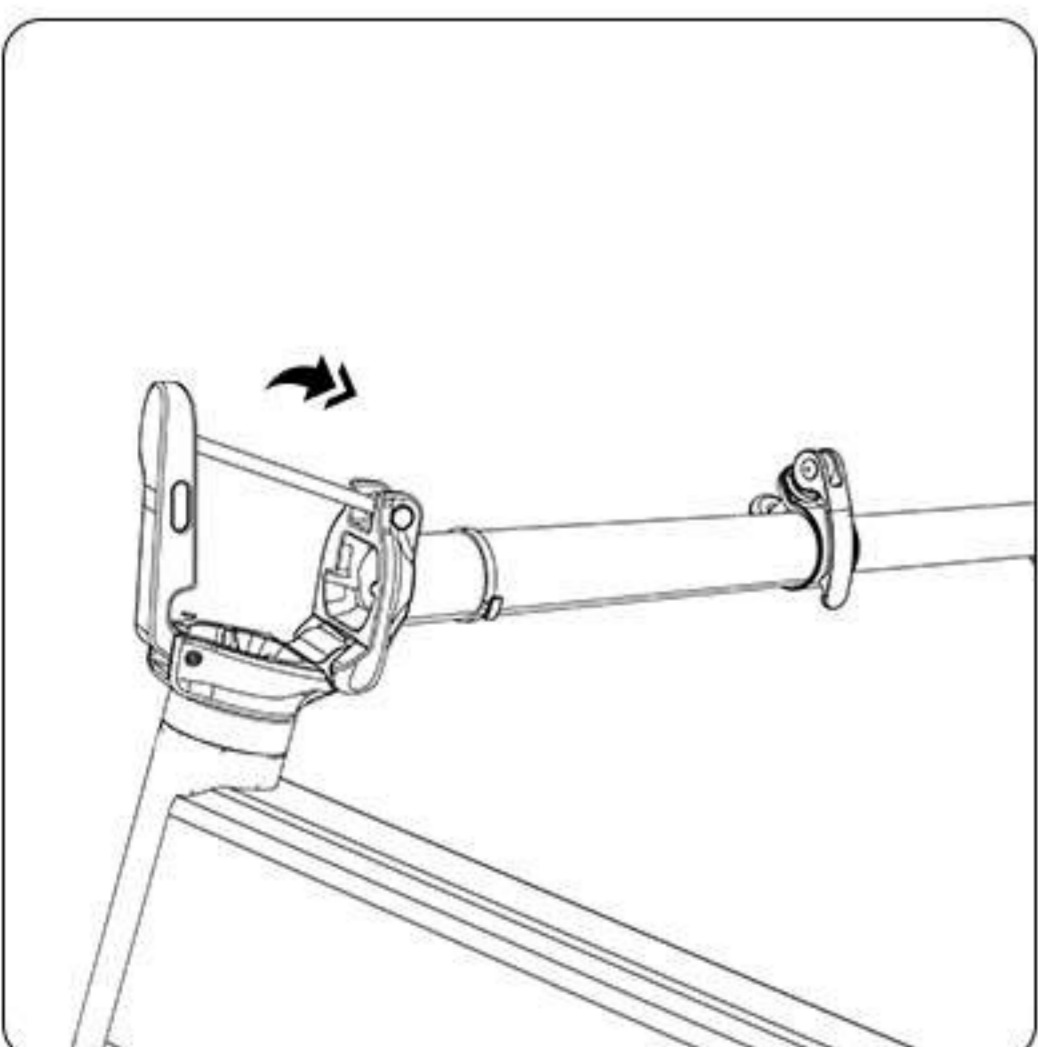

16. Carefully fold the headset stem up.

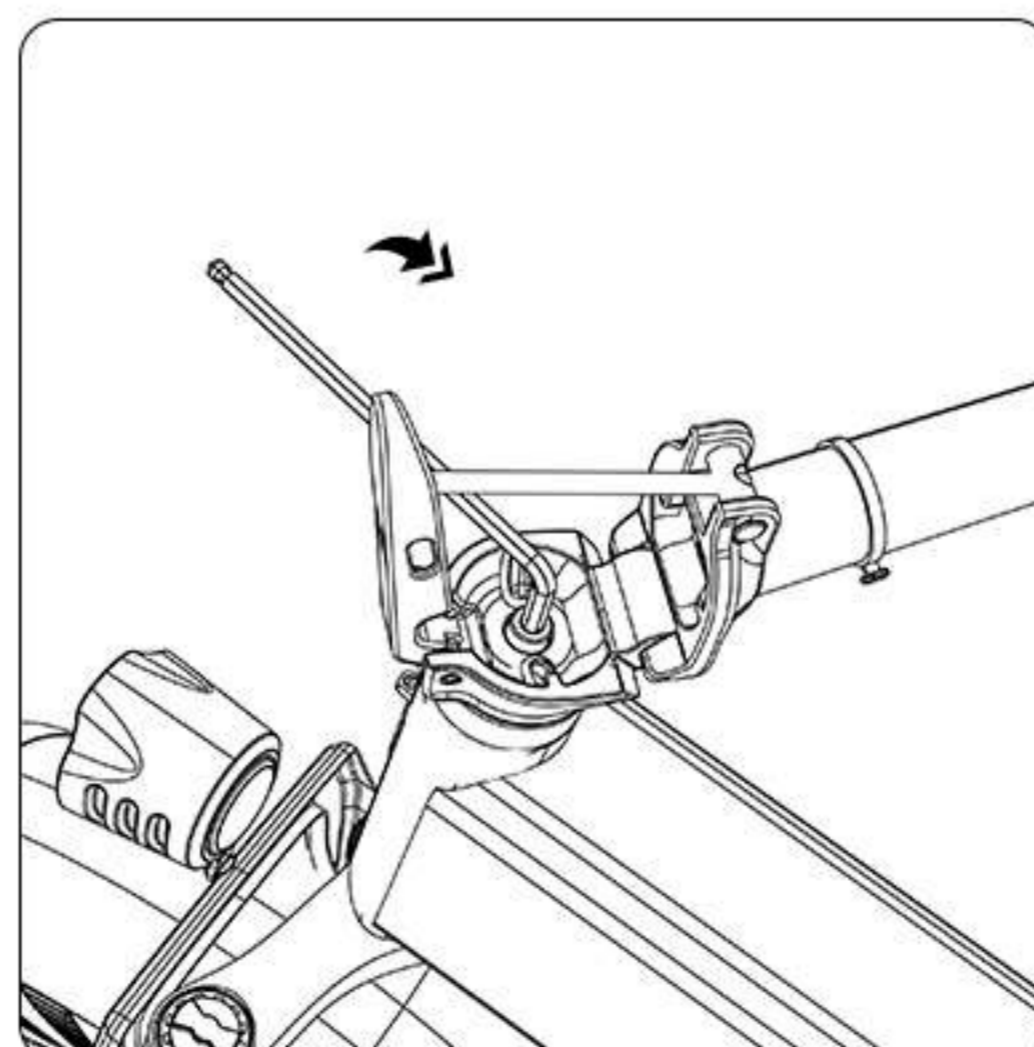

17. Thread in the nut right in the middle with 6mm Allen key but do not tighten it fully.

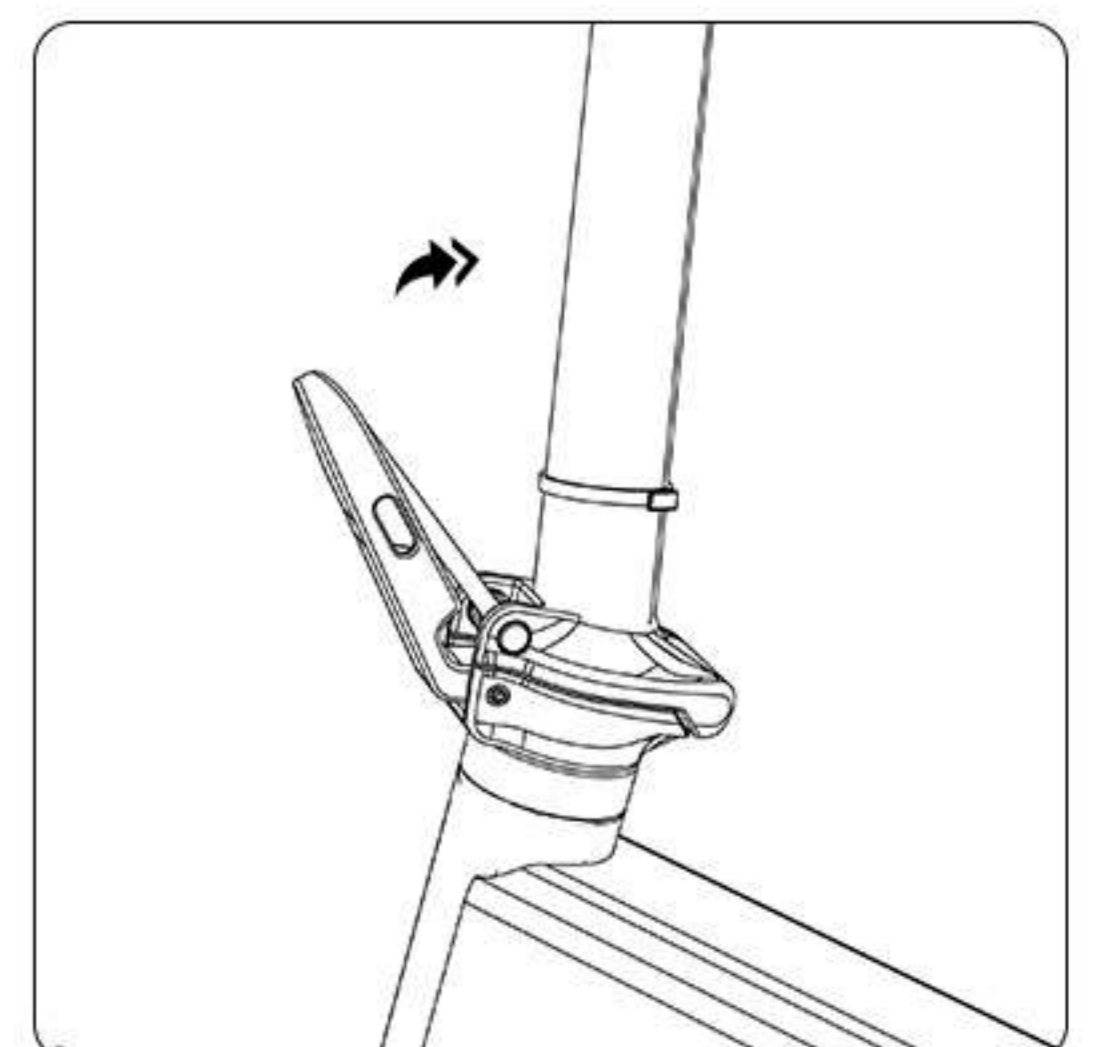

18. Lift the stem riser up and close the hinge release lever.



19. Check if the handlebar and front wheel are perfectly aligned.

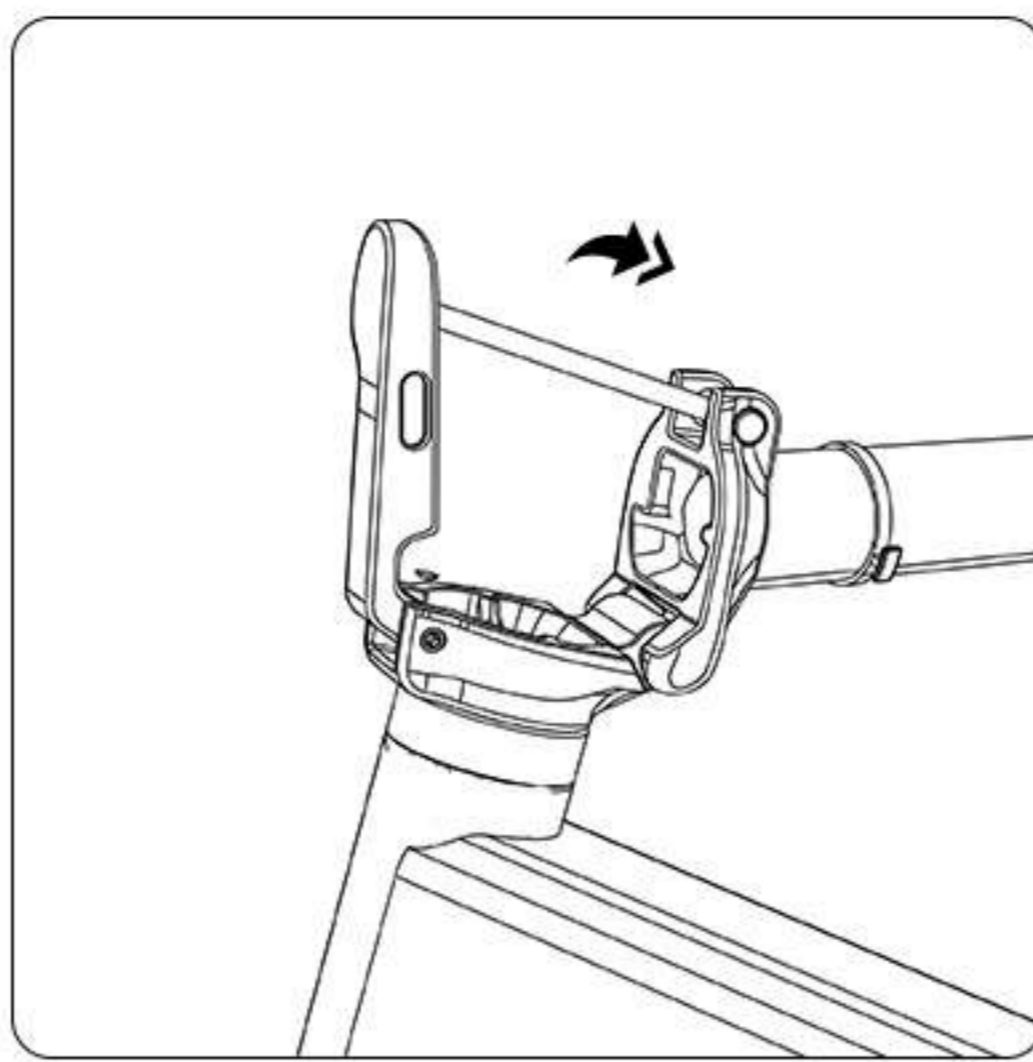

20. Fold the stem up again to fully tighten the nut inside.

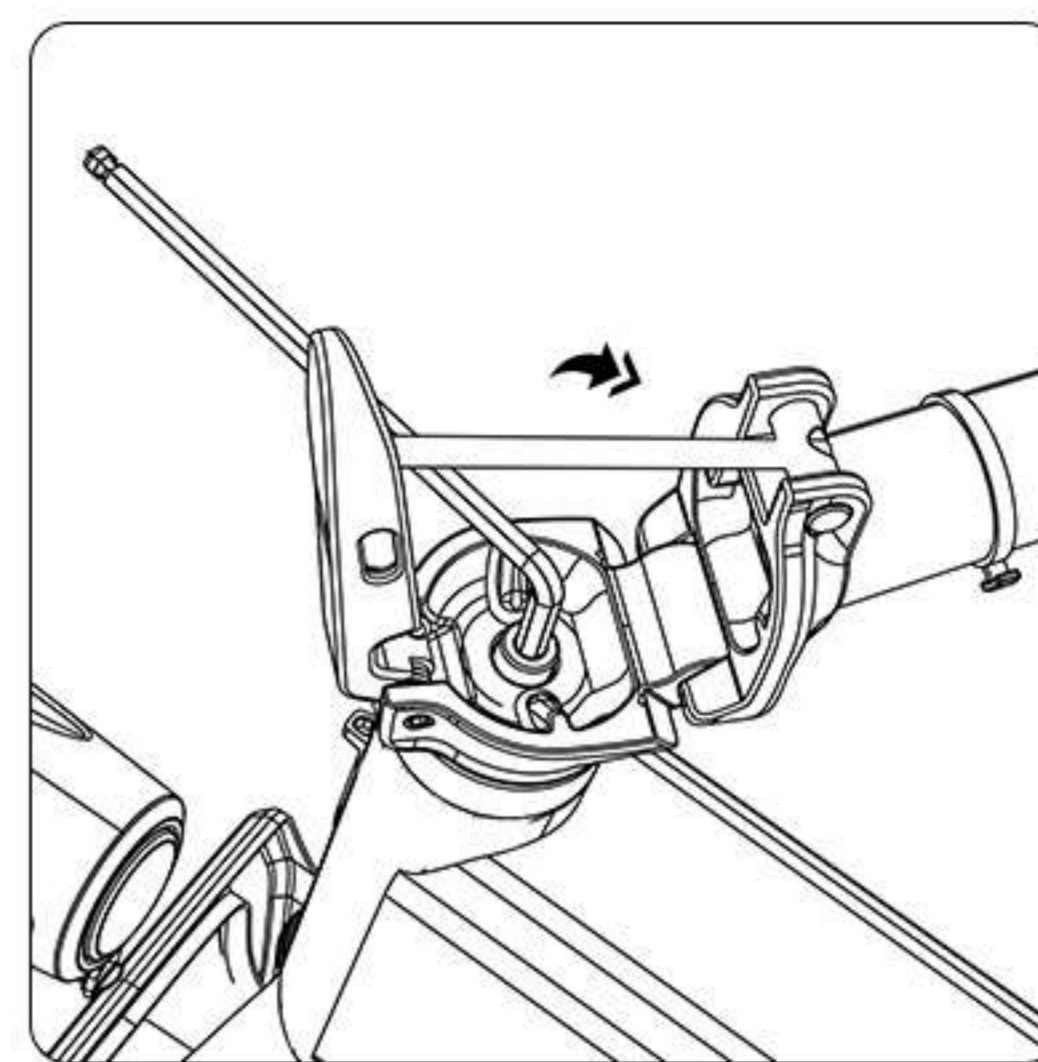

21. Clockwise rotate the Allen key to full tighten the nut.

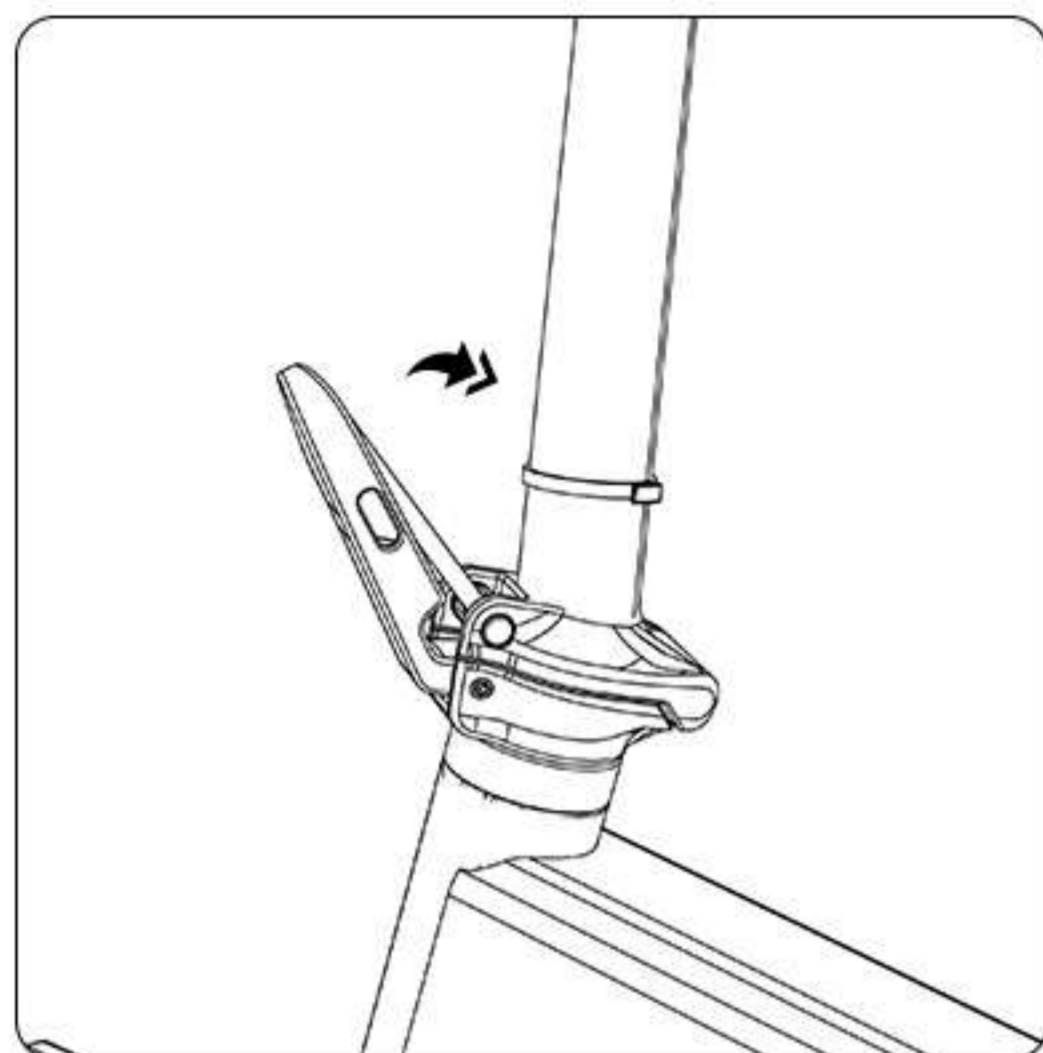

22. Close the stem riser folding mechanism.

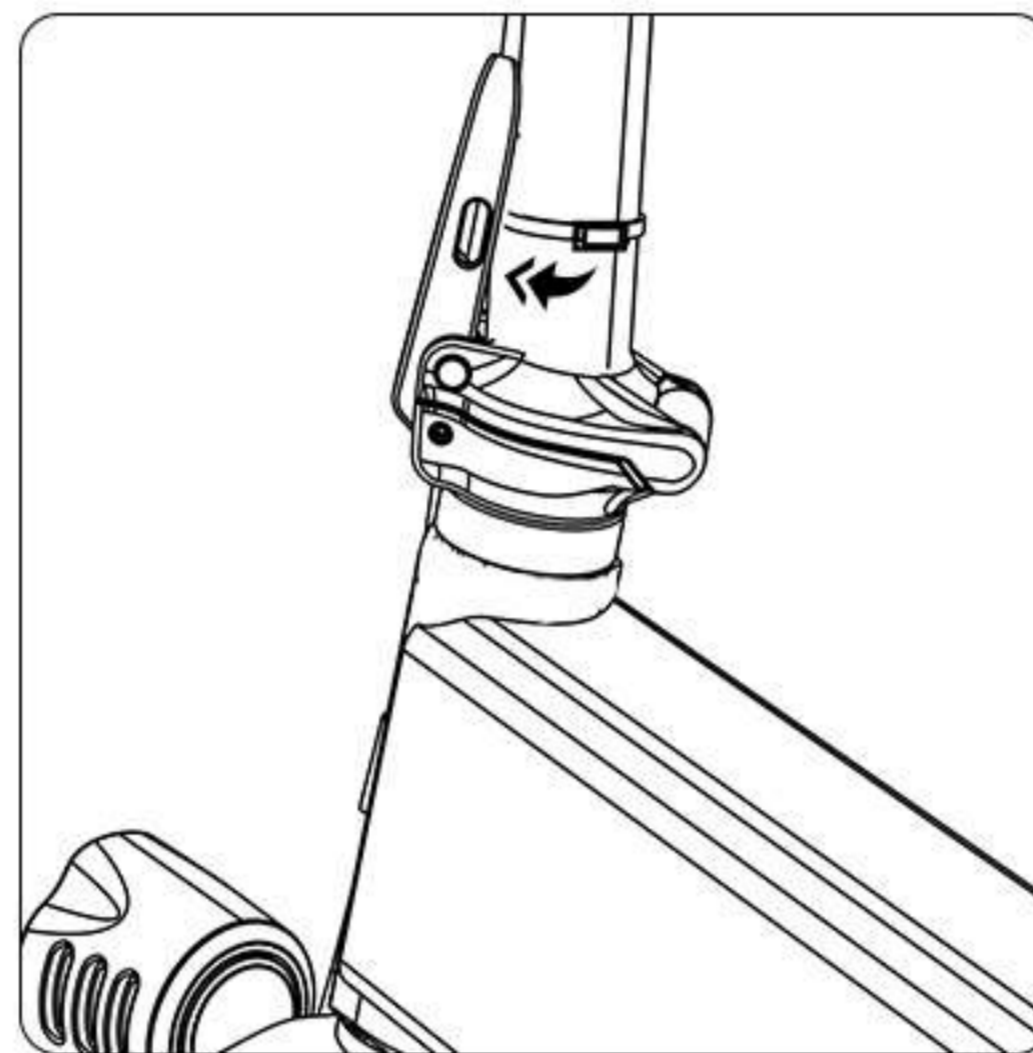

23. Clockwise tweak the safety collar to secure the lever in place.

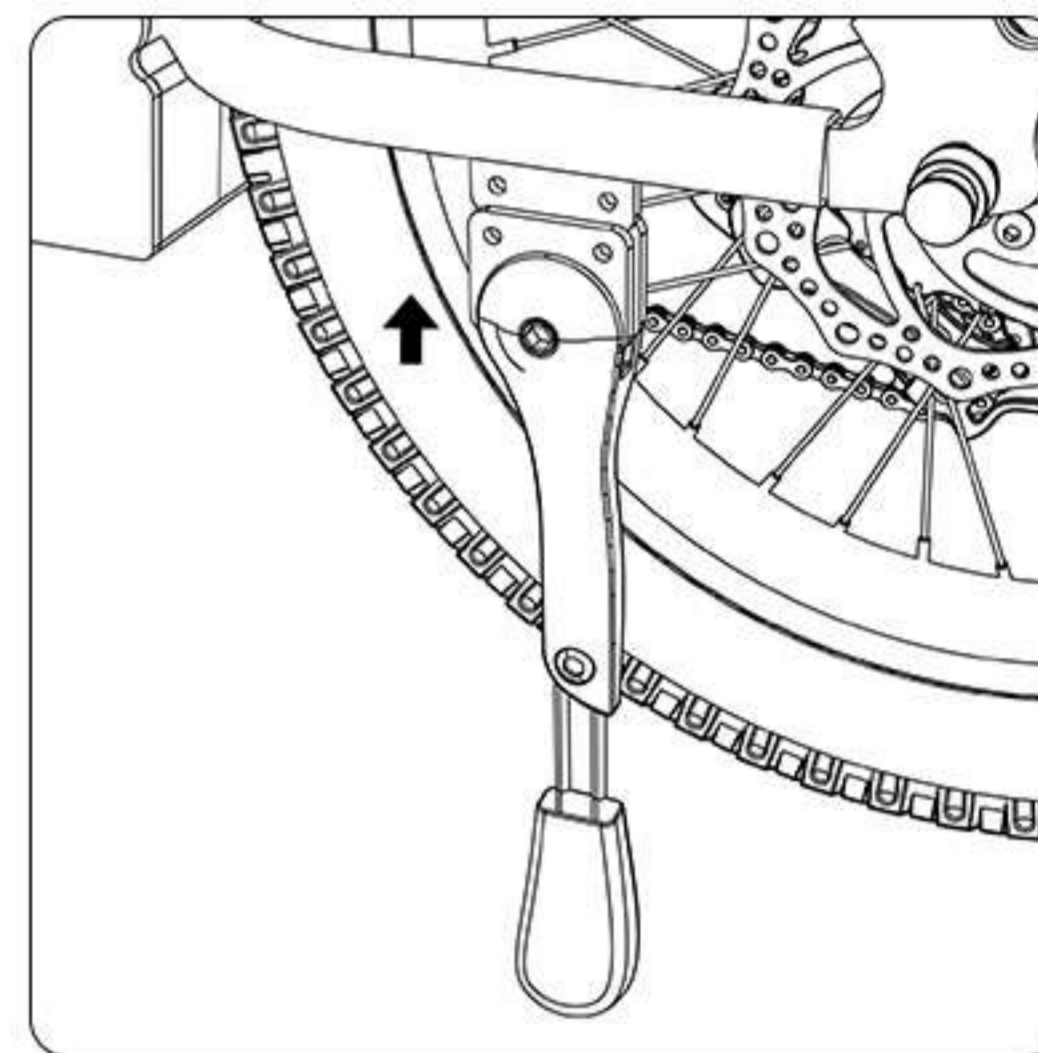

24. Attach the kickstand onto the bike mounting bracket.

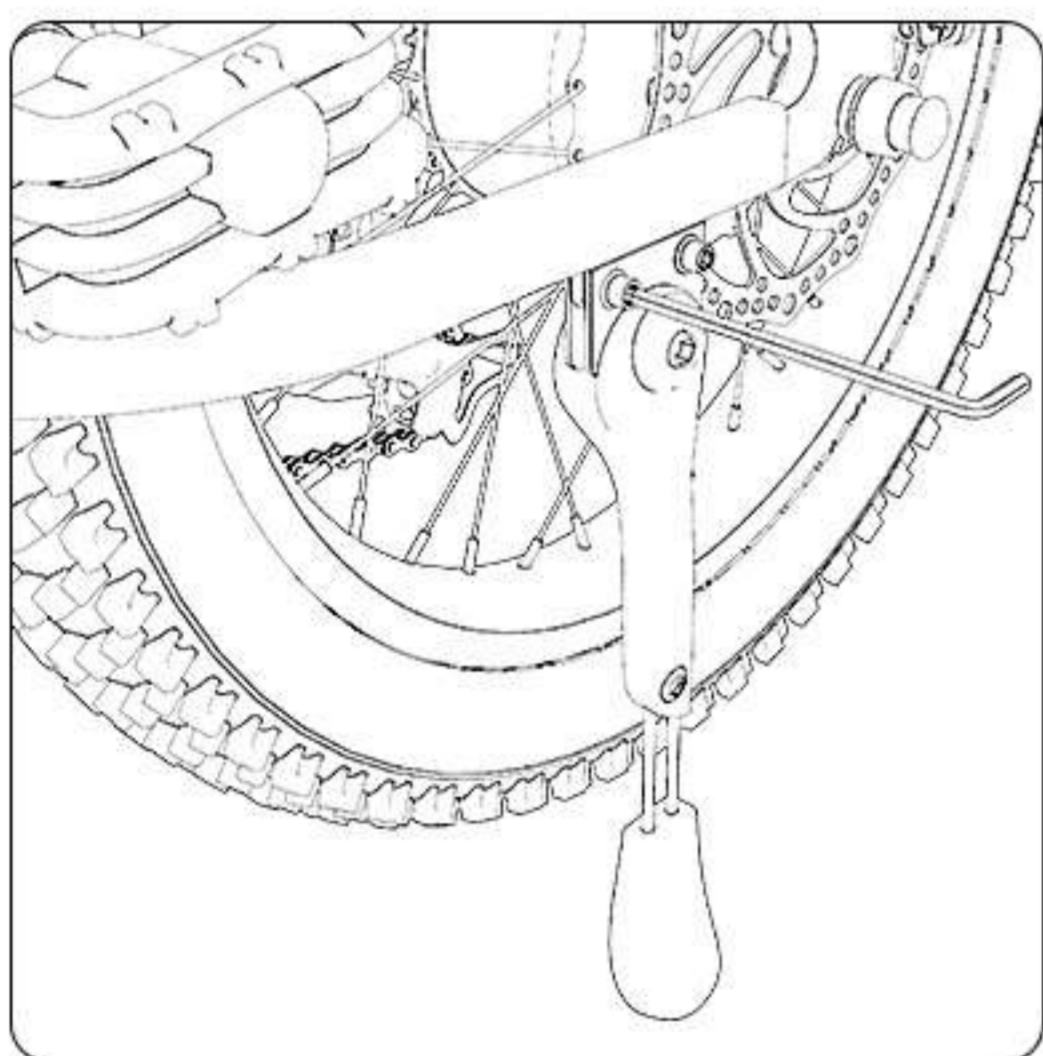

25. Entirely tighten up the bolts with a 5mm Allen key to ensure the kickstand will not wiggle or fall out.

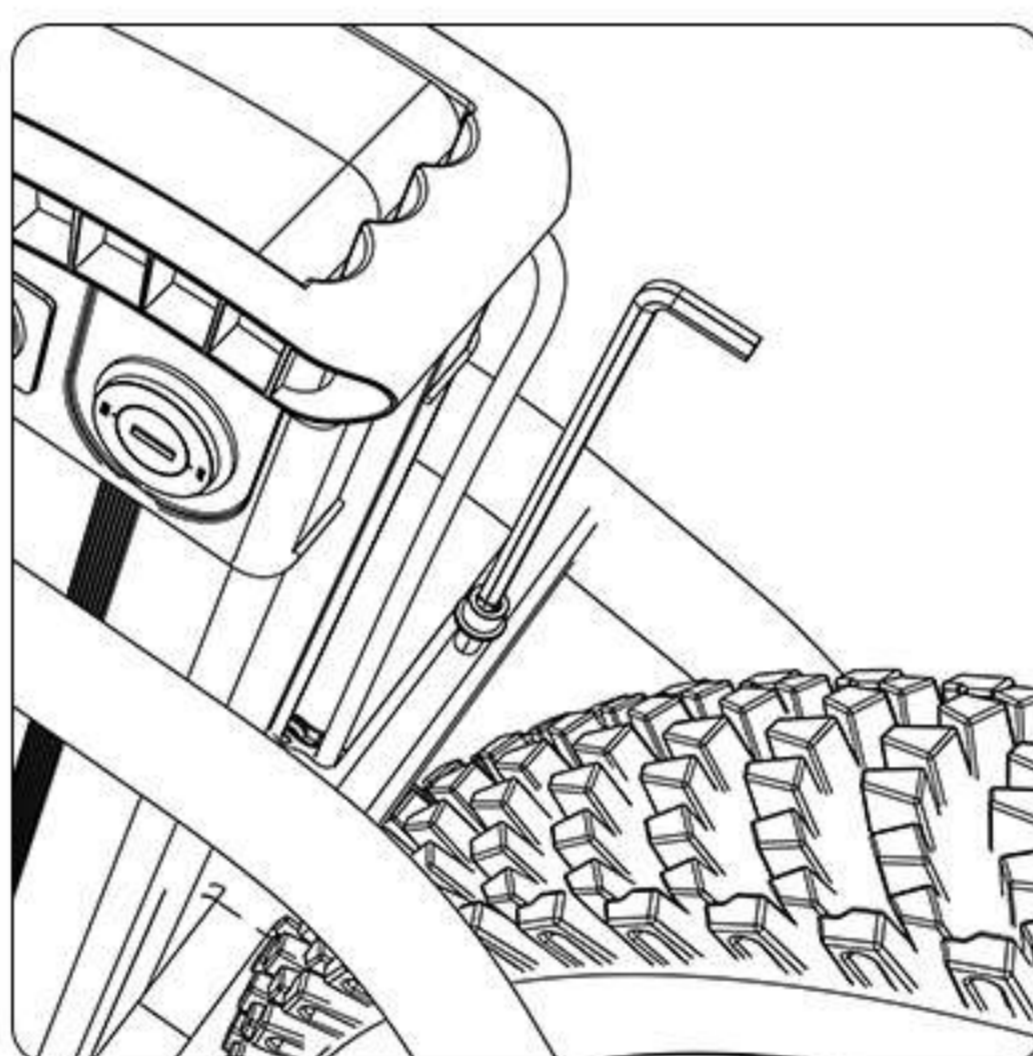

26. Use a 4mm Allen key to remove one bolt from the seat stay bridge.

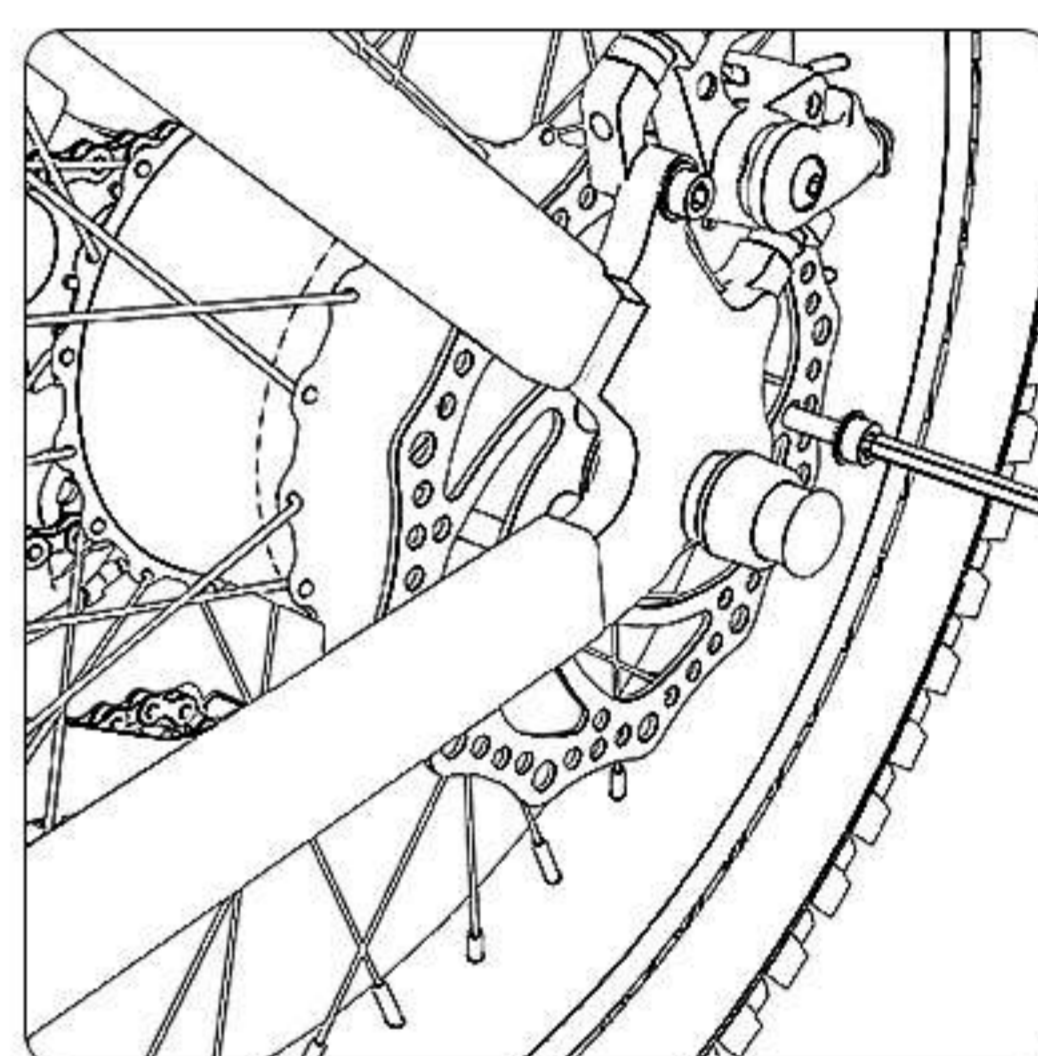

27. Remove two bolts from the rear ends of the seat stays.

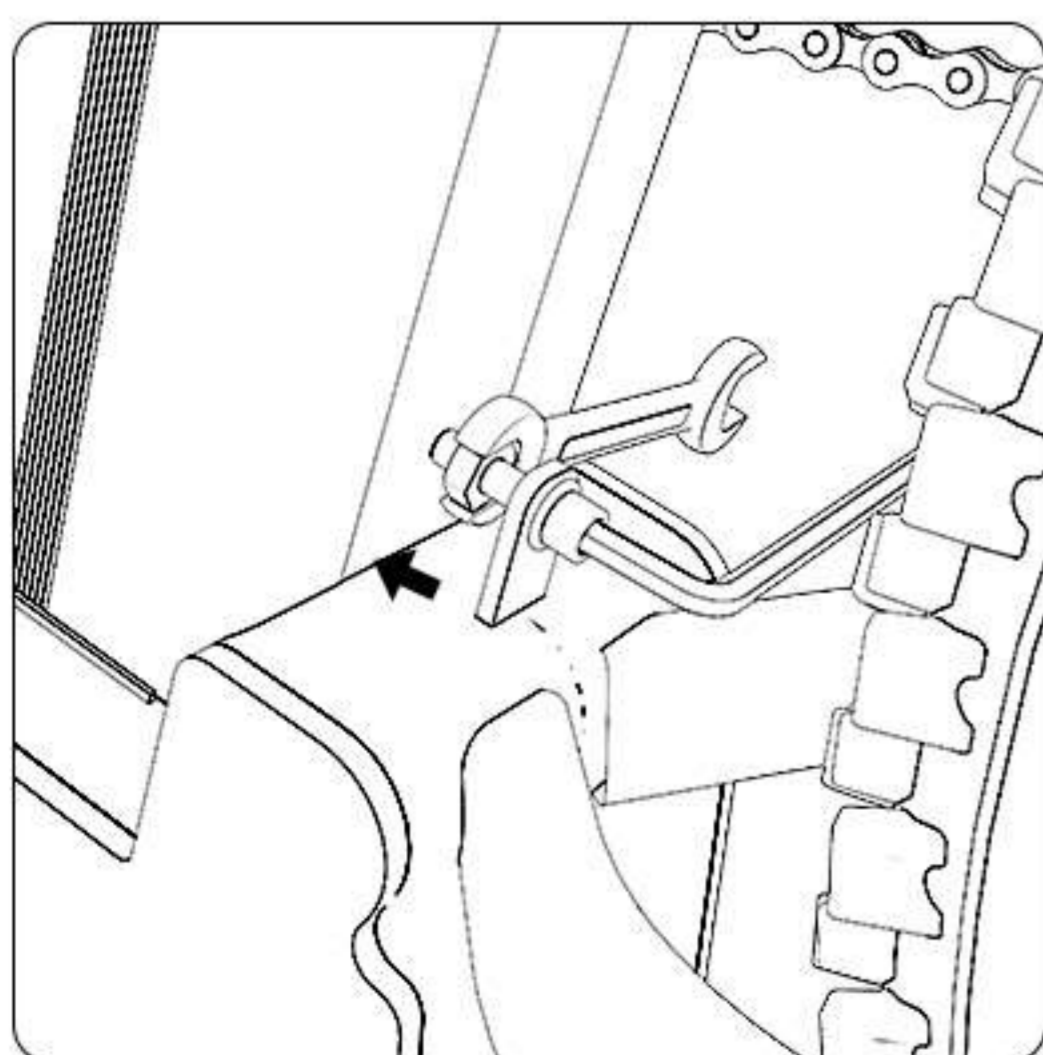

28. Remove a nut and a spacer from the chain stay by hand or with a wrench.

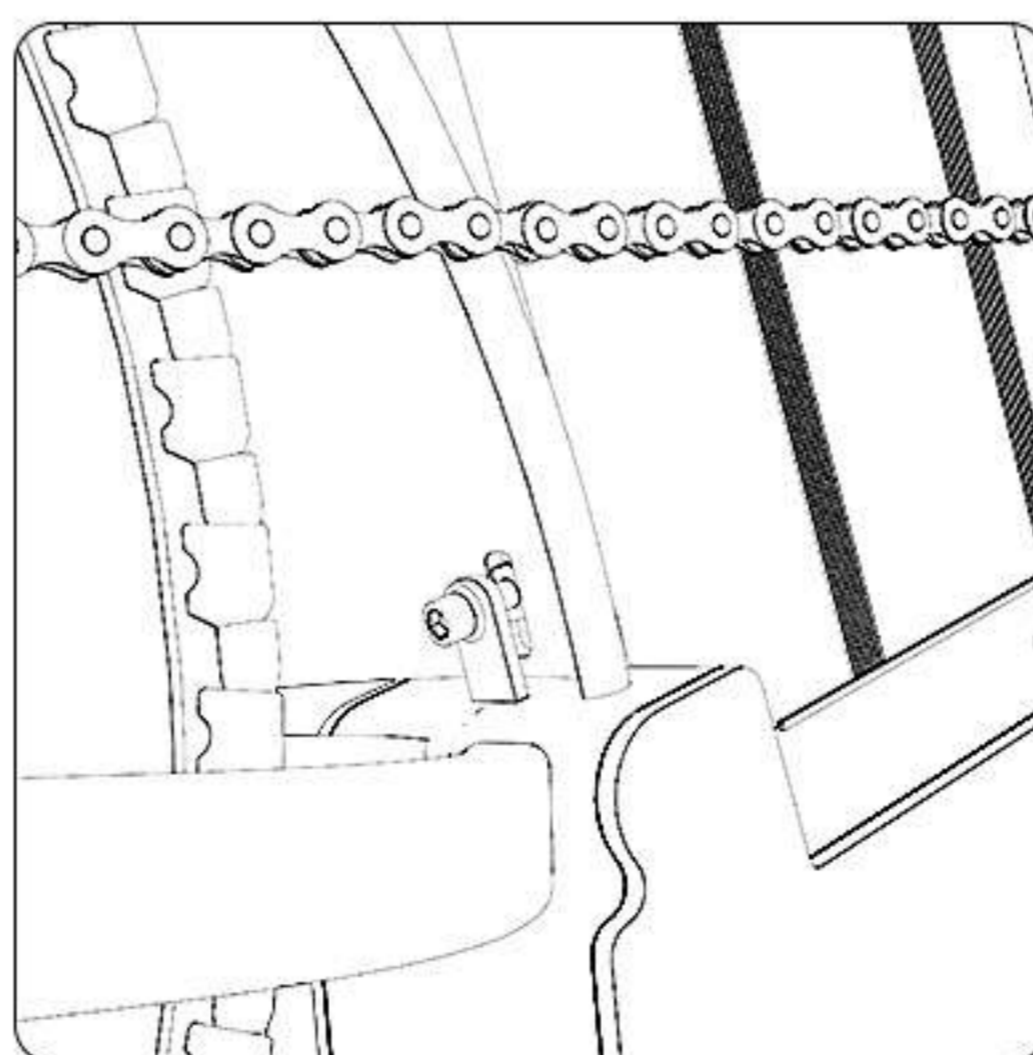

29. Place the rear fender onto the bike. Then attach the spacer, thread the nut onto the bolt by hand until you feel the thread click into place.

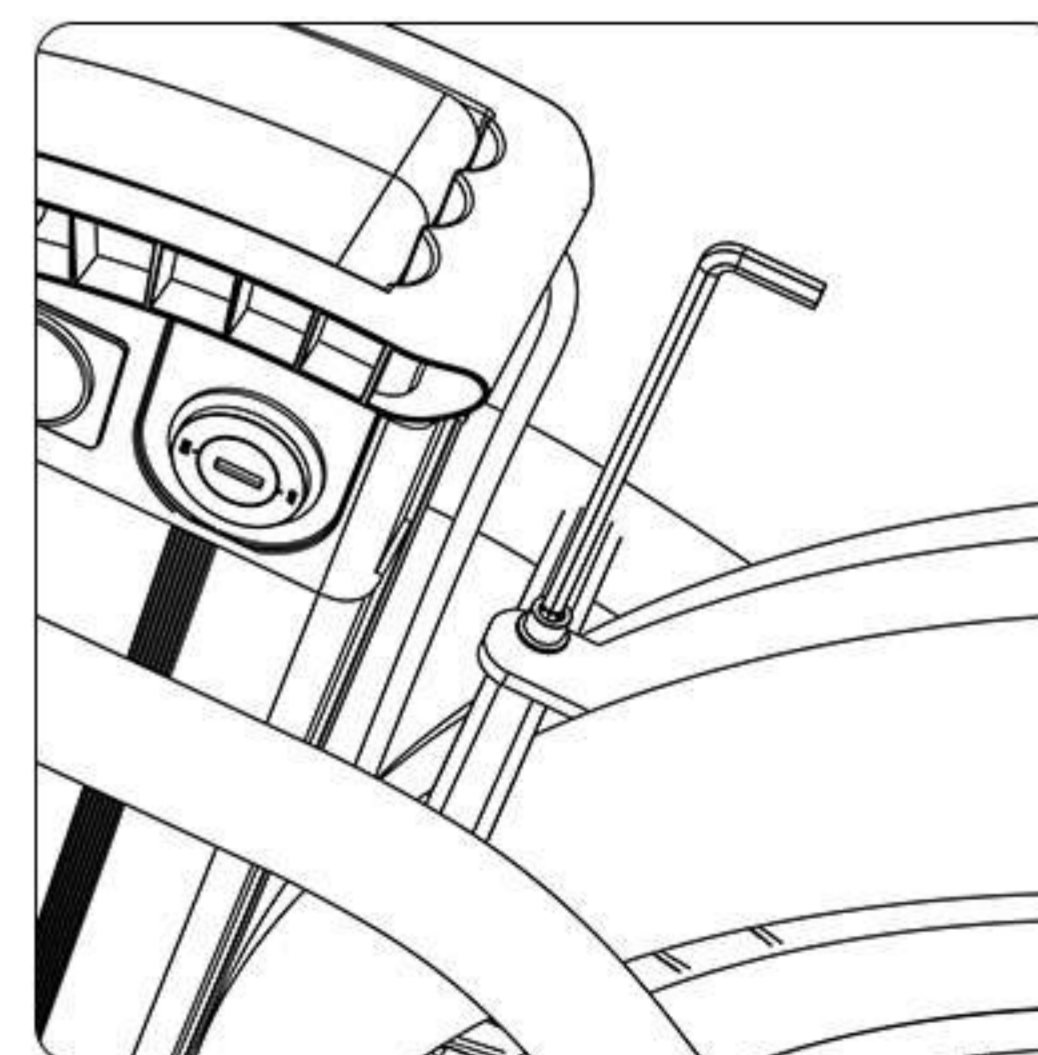

30. Pass the bolt through the L-shaped mounting bracket on the fender, attach it to the mounting hole on the seat stay bridge, then screw in the nut.

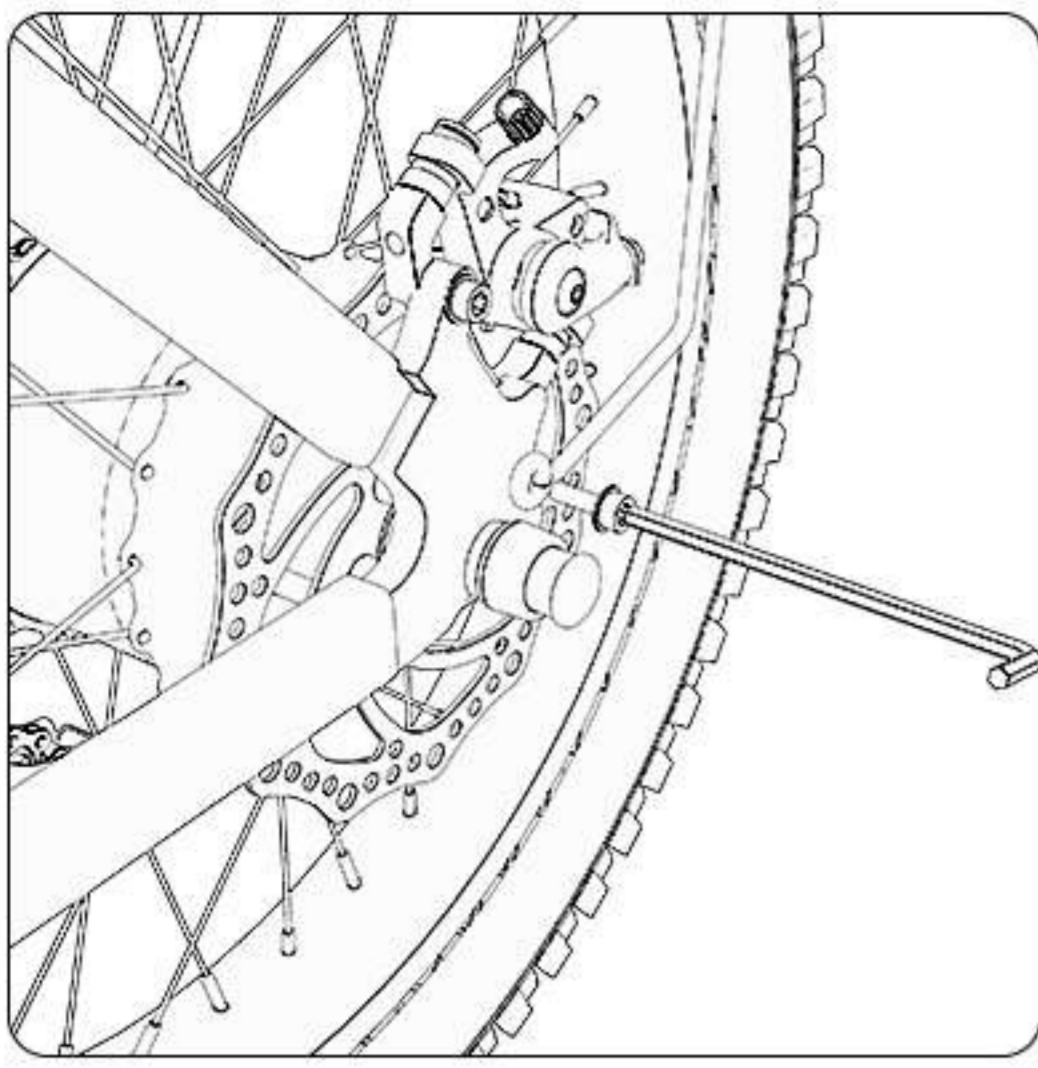

31. Pass the bolts through the eyelets on both braces of the fender, and then align them with the holes on the bike. Then have them fully tightened.

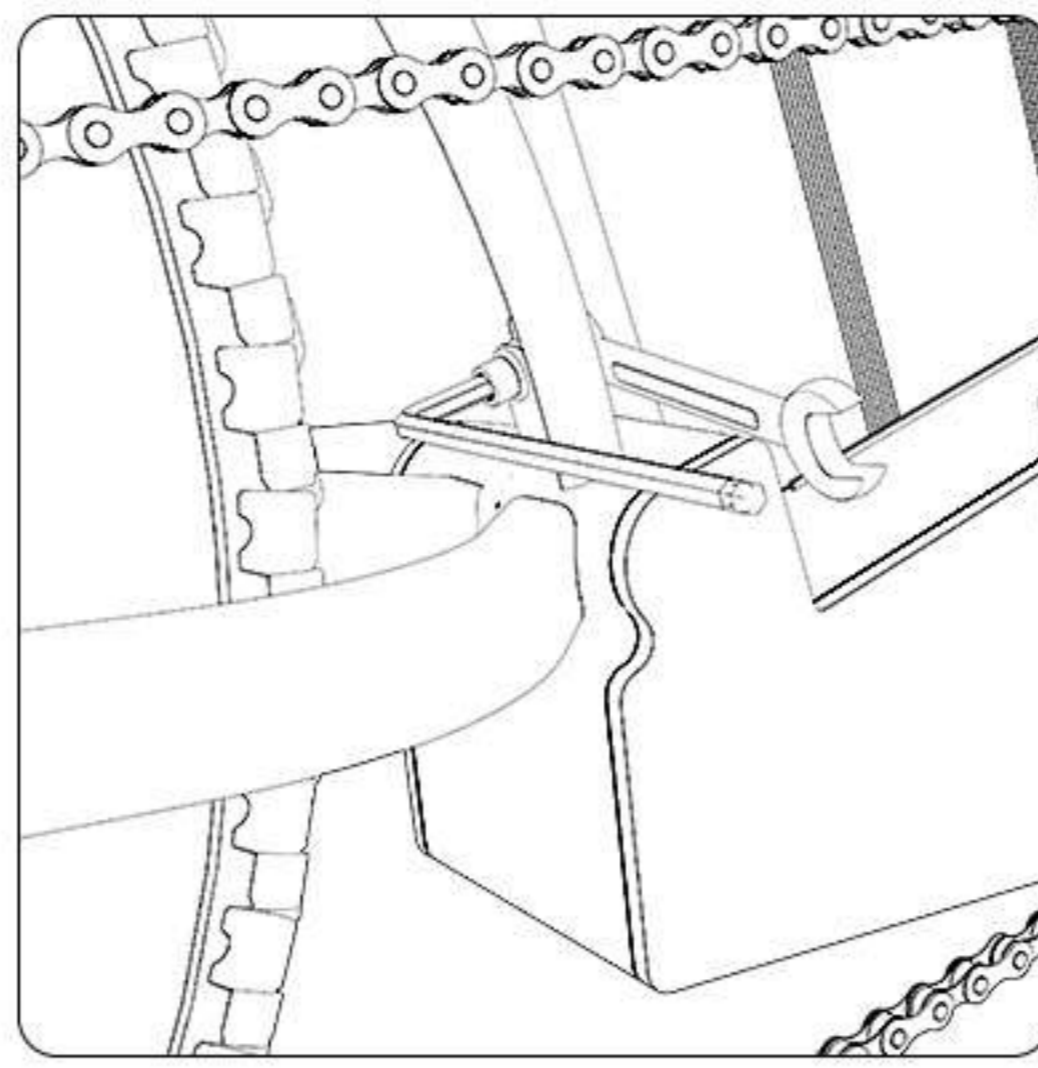

32. To fully tighten this nut, position an Allen key on the head of the bolt by one hand.

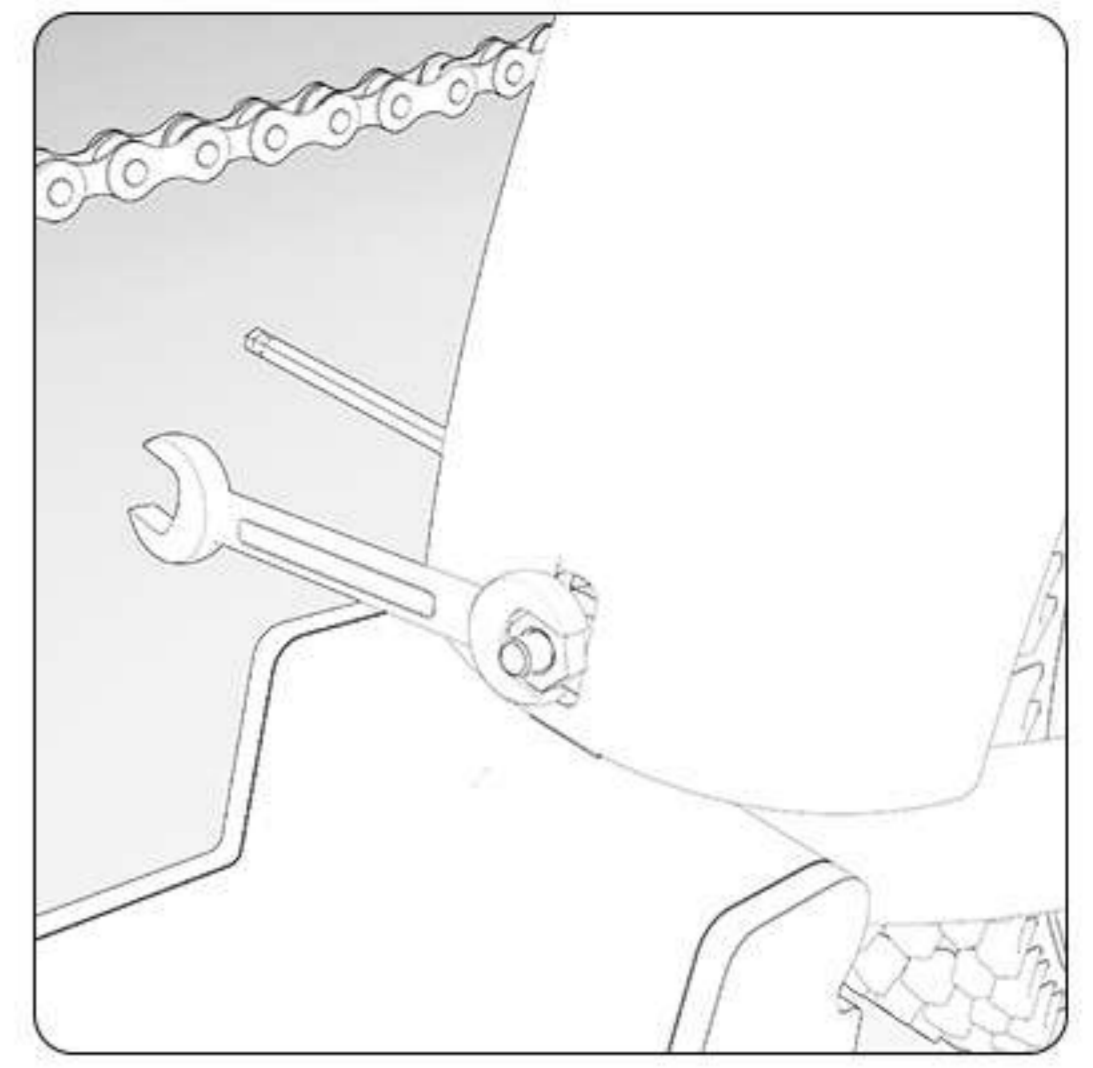

33. Use a wrench to turn the nut clockwise with the other hand until it no longer turns.

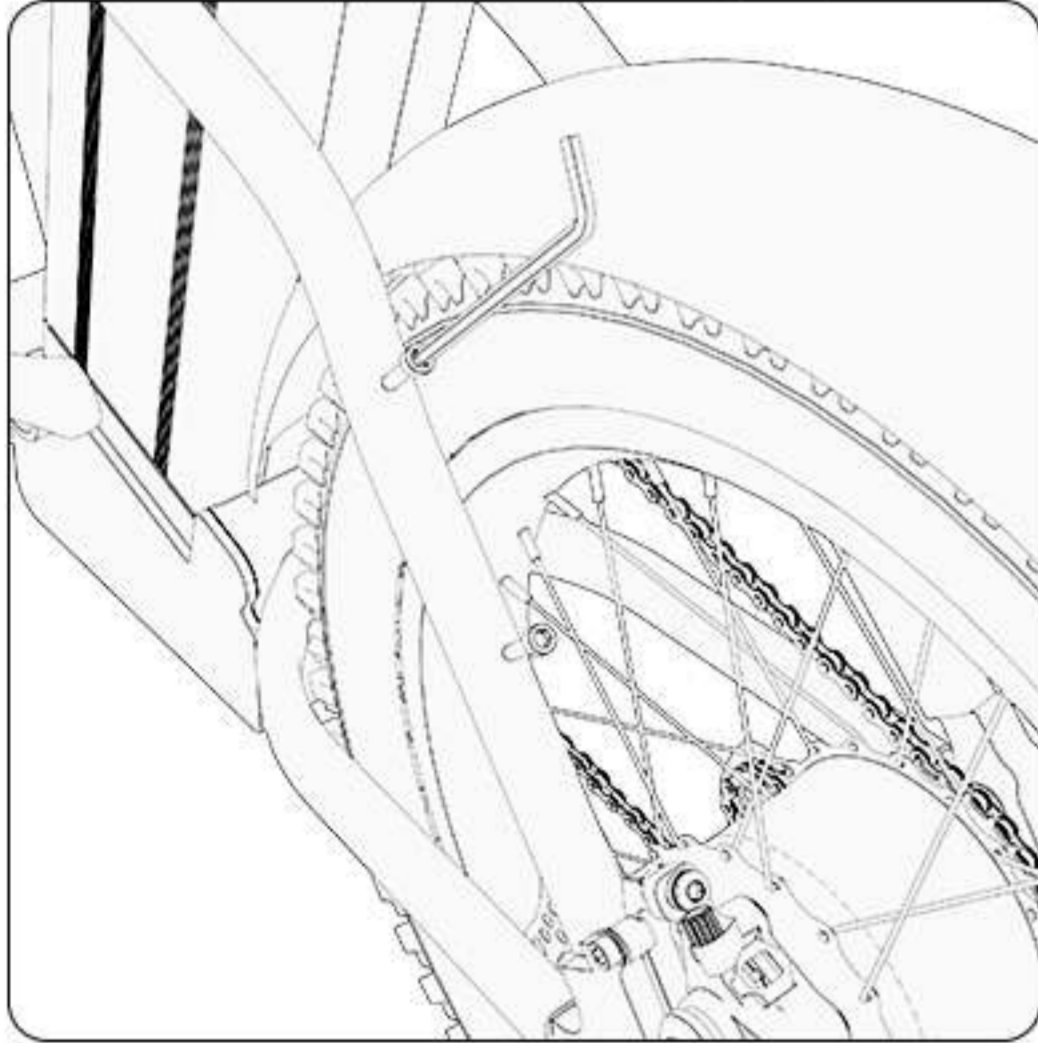

34. Remove the four bolts that are used to secure the struts of the rear rack on the seat stays with 4mm Allen key.

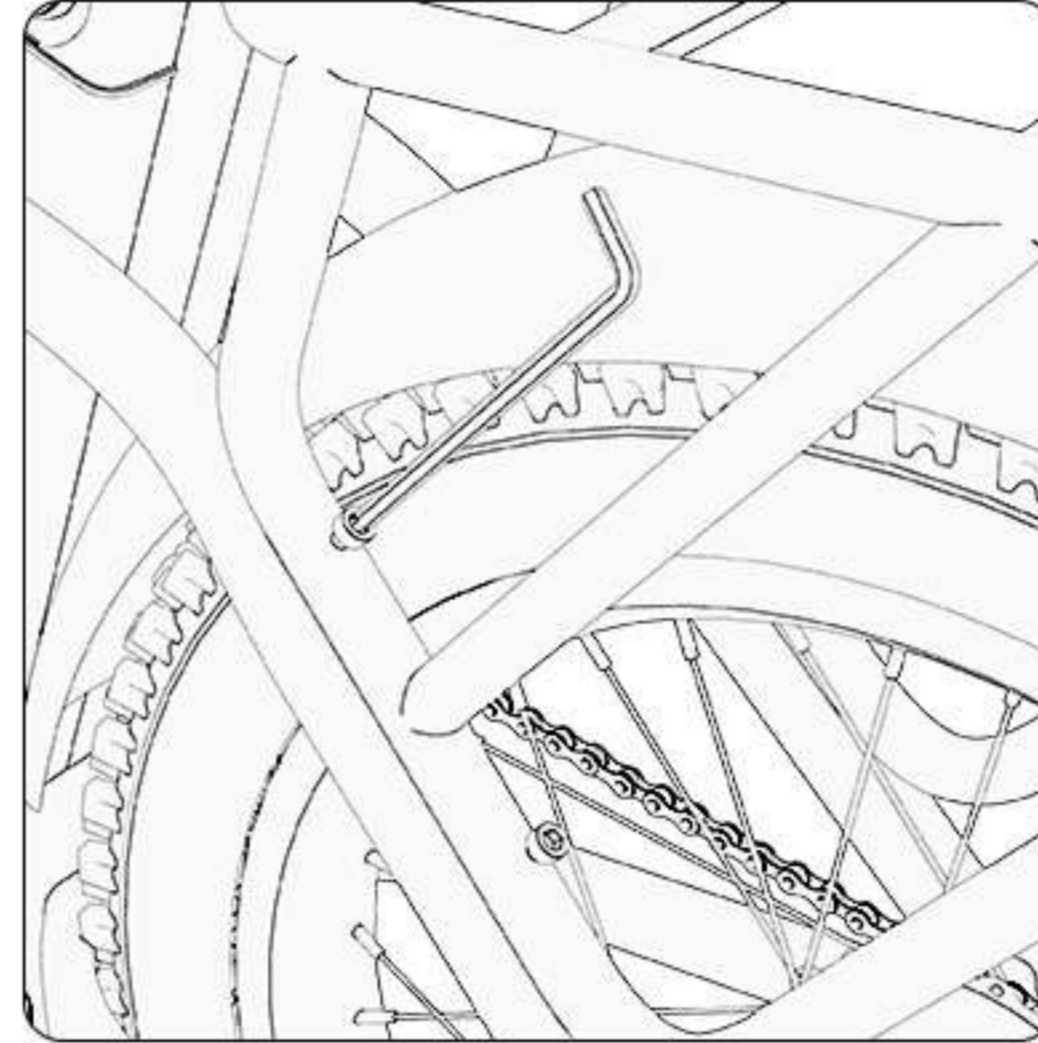

35. Place the rear rack over the bike and then tighten the struts at each side with bolts.

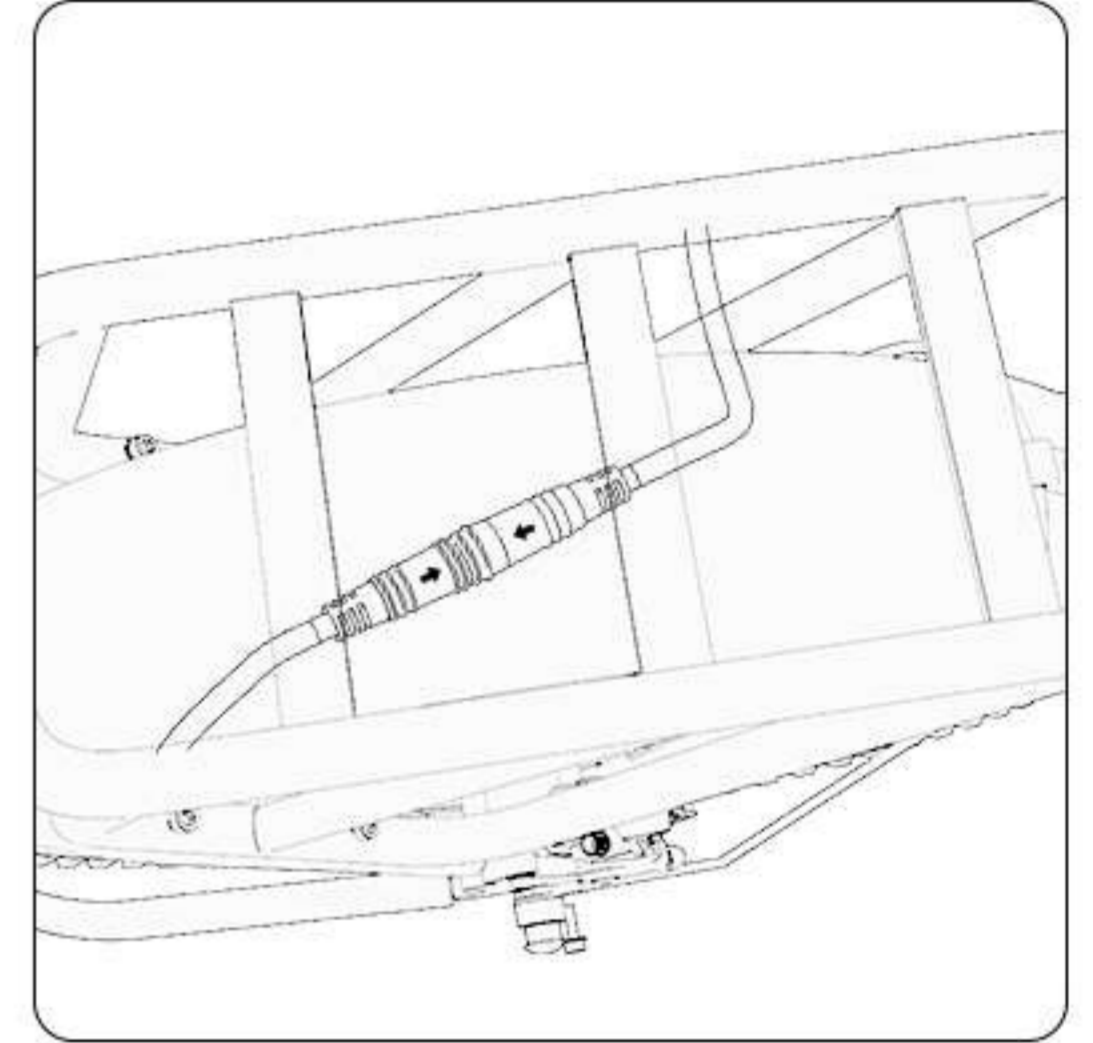

36. Plug in the taillight connector as per the directed arrow on it.

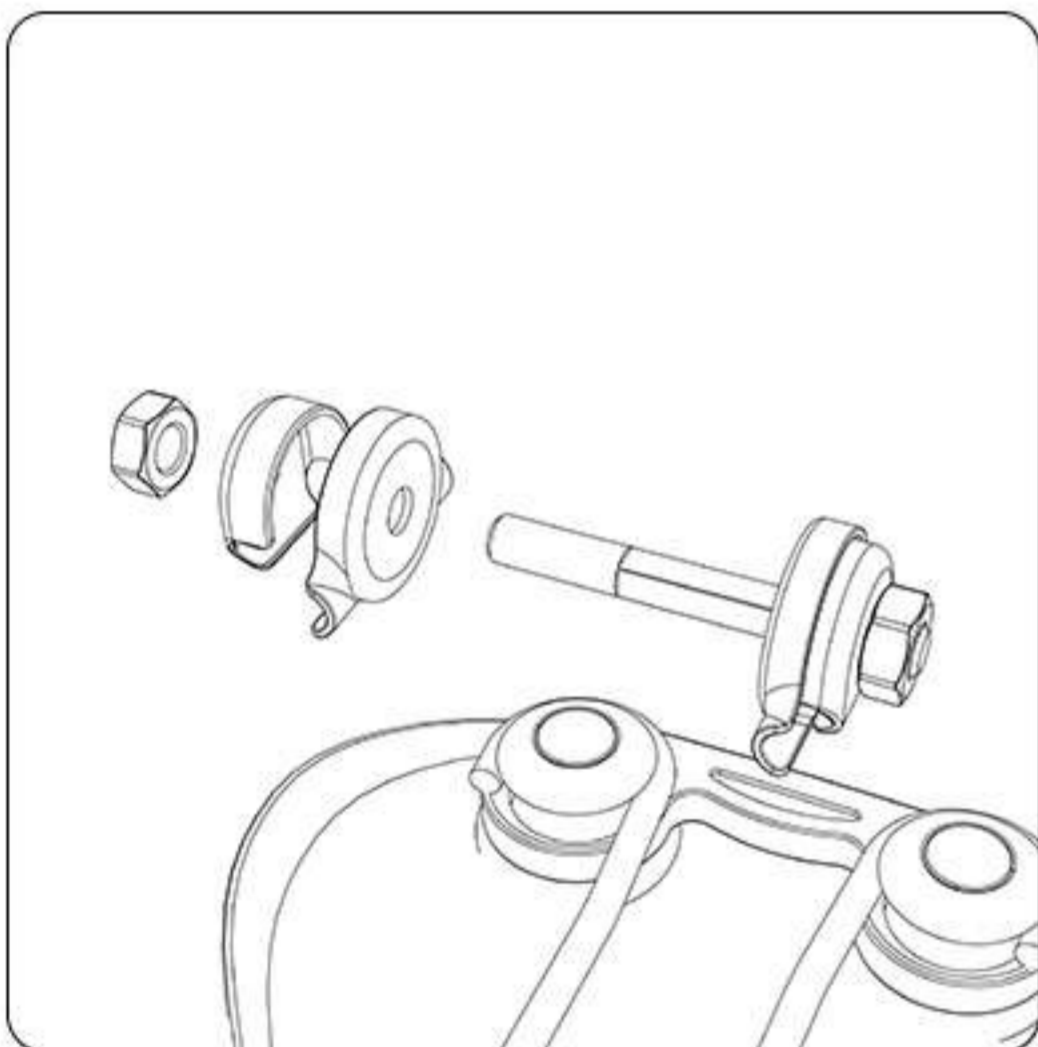

37. Locate the seat guts. On either side, remove one threaded nut and two metal pieces that are used to cradle and lock the seat rail.

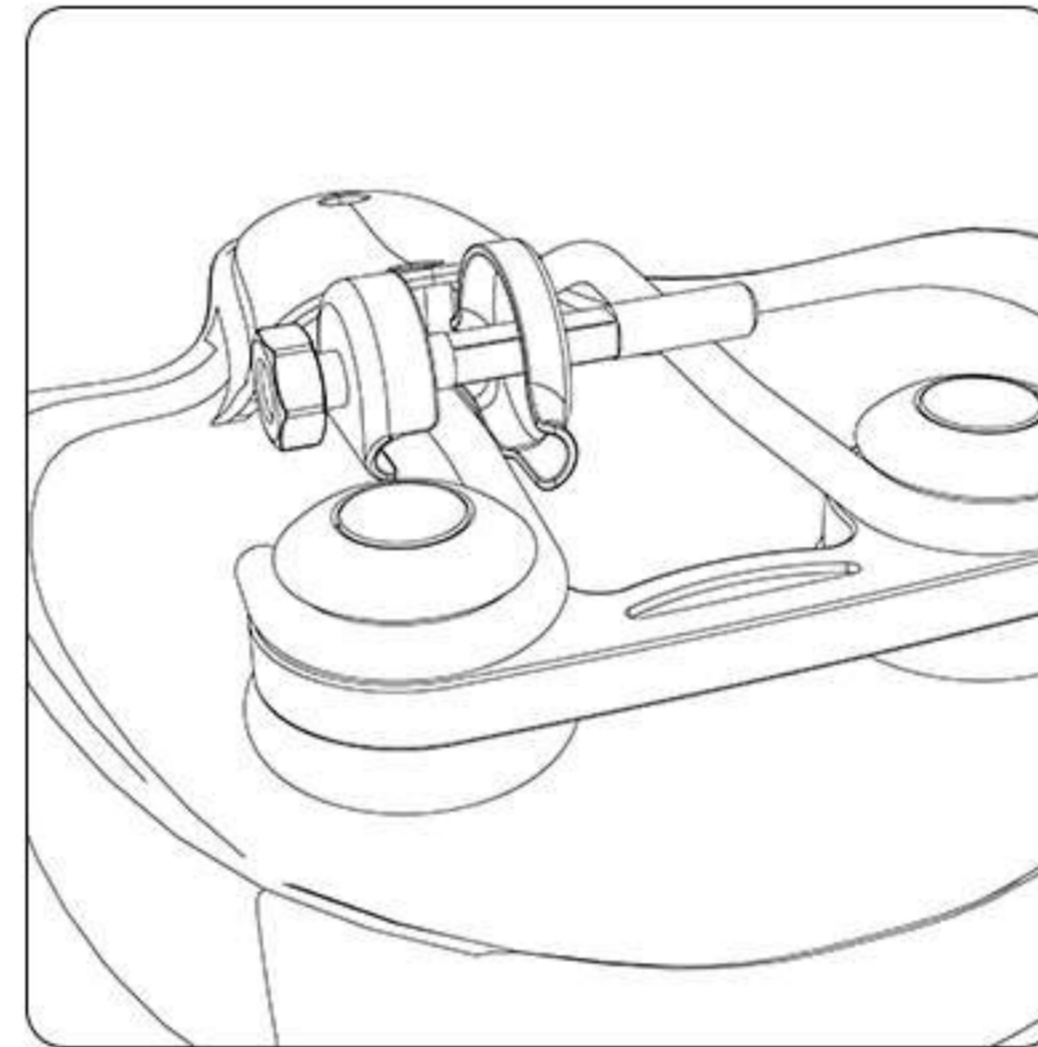

38. Attach the seat guts onto the back of the saddle.

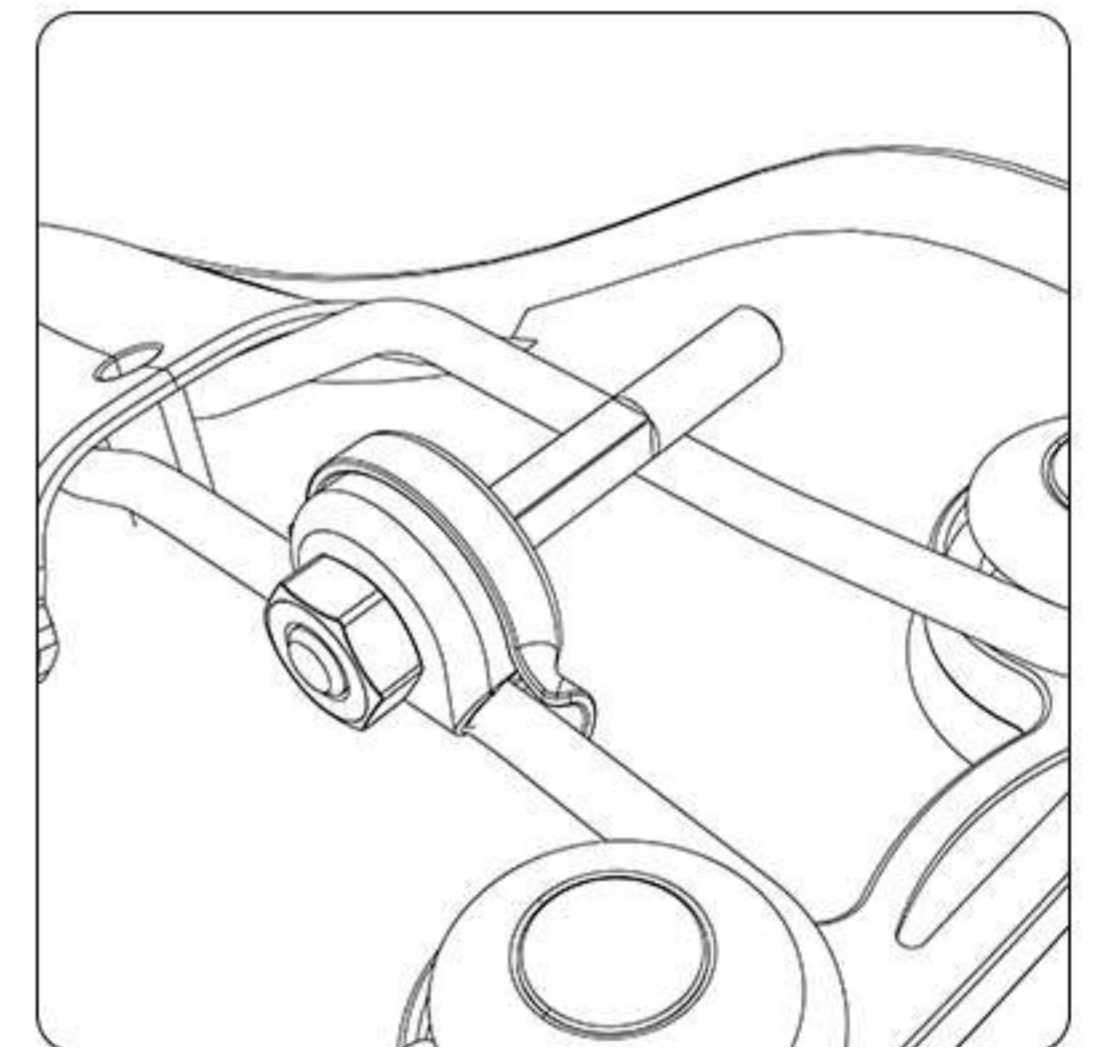

39. Clamp the seat rail with the two metal pieces left on the shaft. Then pass the shaft through the holes on top of the seat post.

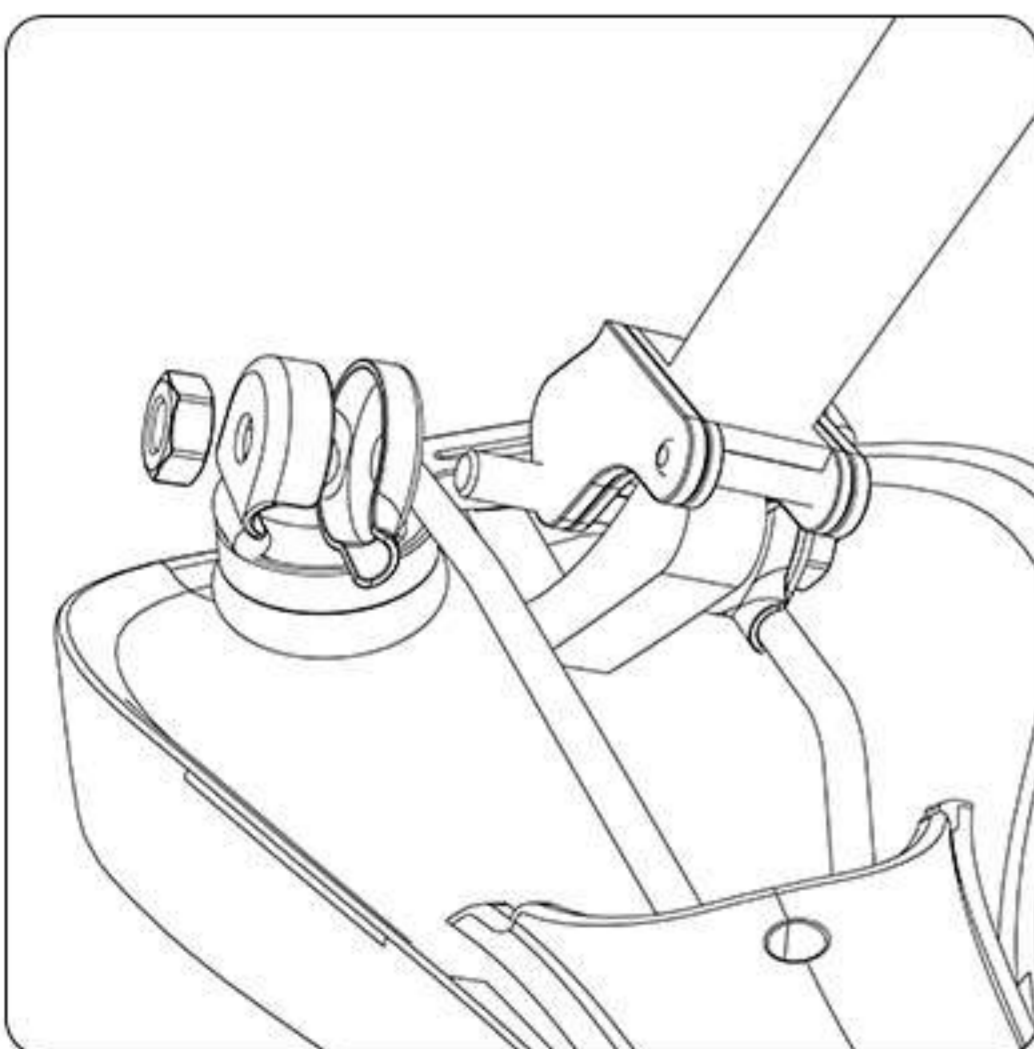

40. Gently tip the seat post to the side, then lay the metal piece on the seat rail, and slide the shaft through the metal piece with its serrated pattern pointed inside.

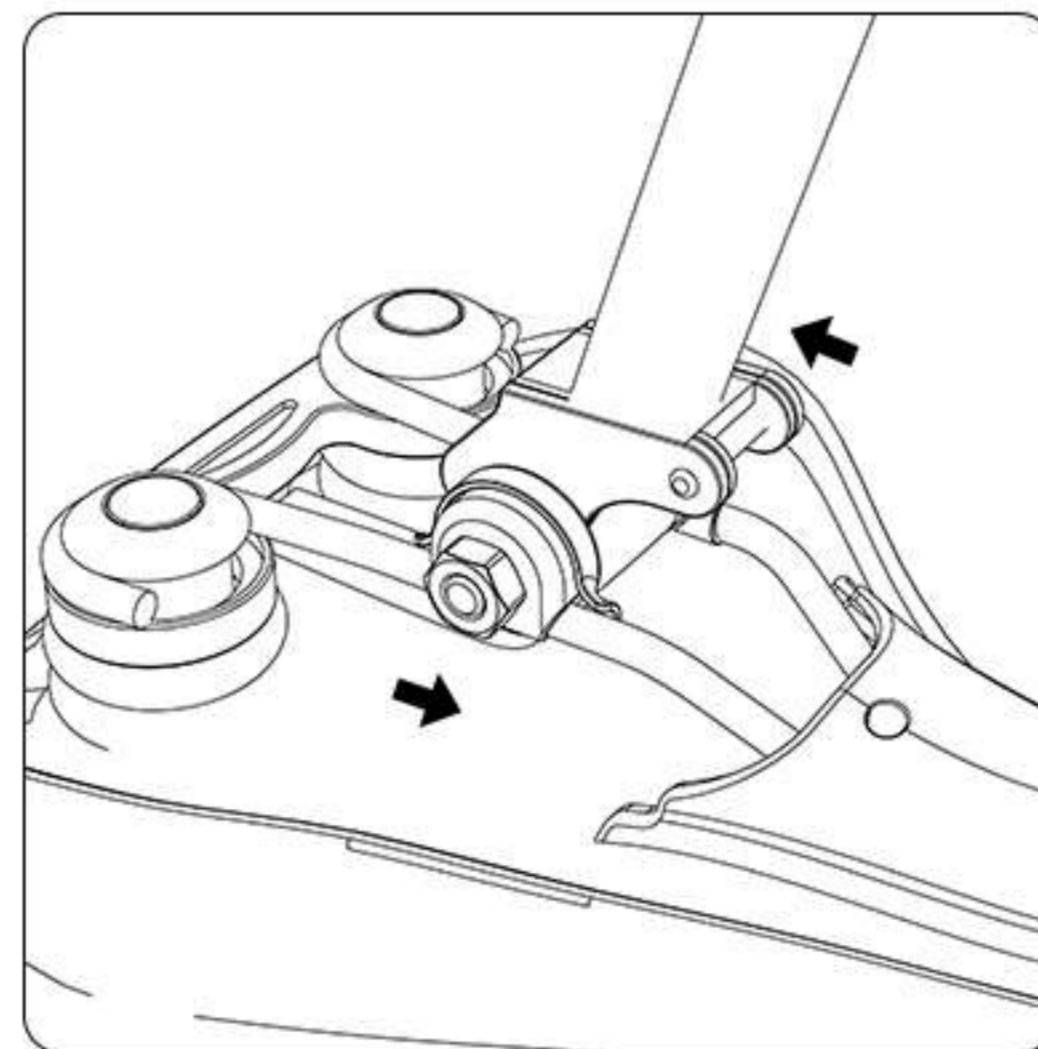

41. Attach the other metal piece to click into place, and thread in the nut by hand.

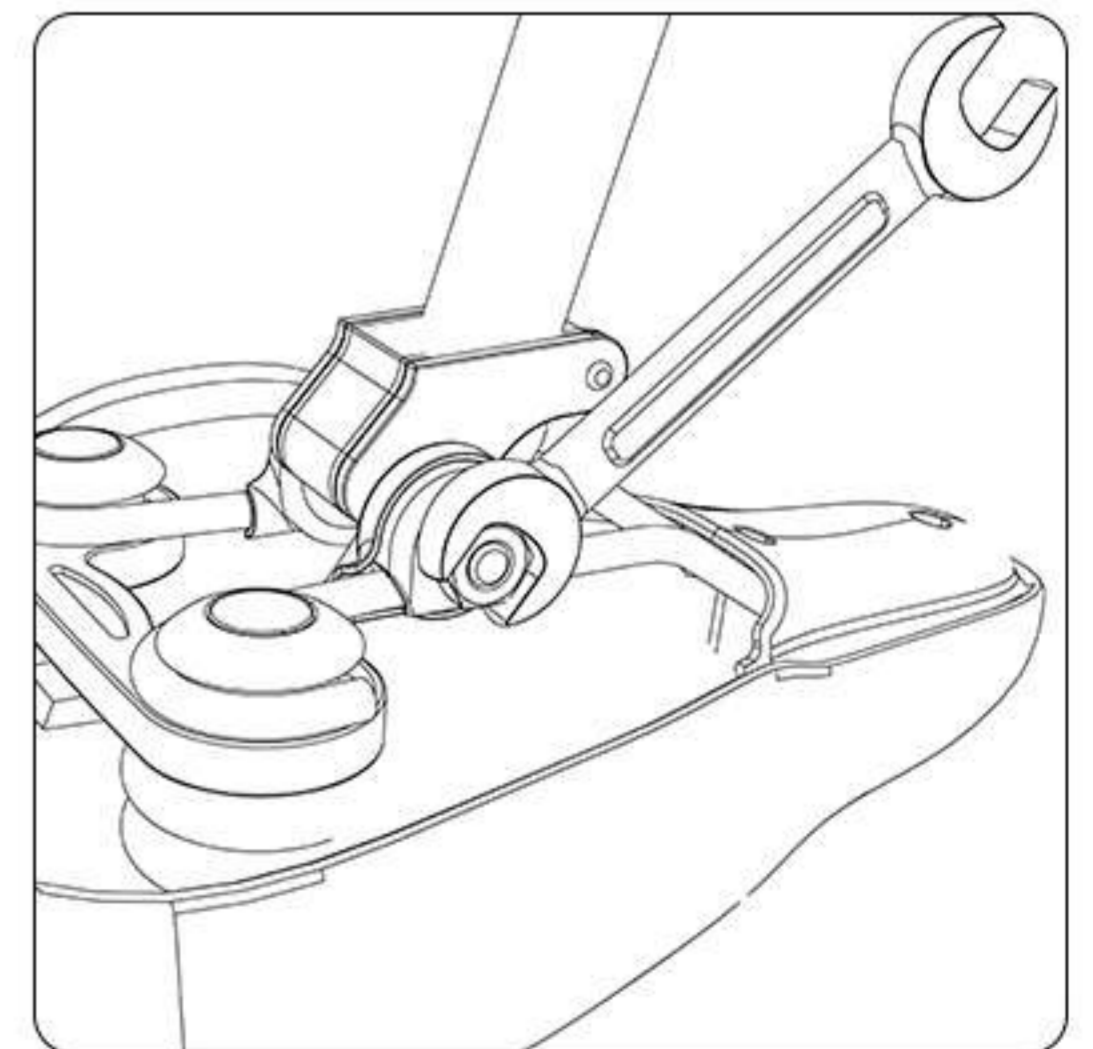

42. Slide the seat post to ensure your seat is in the correct forward position. Then full tighten the nuts up with a 14mm wrench.

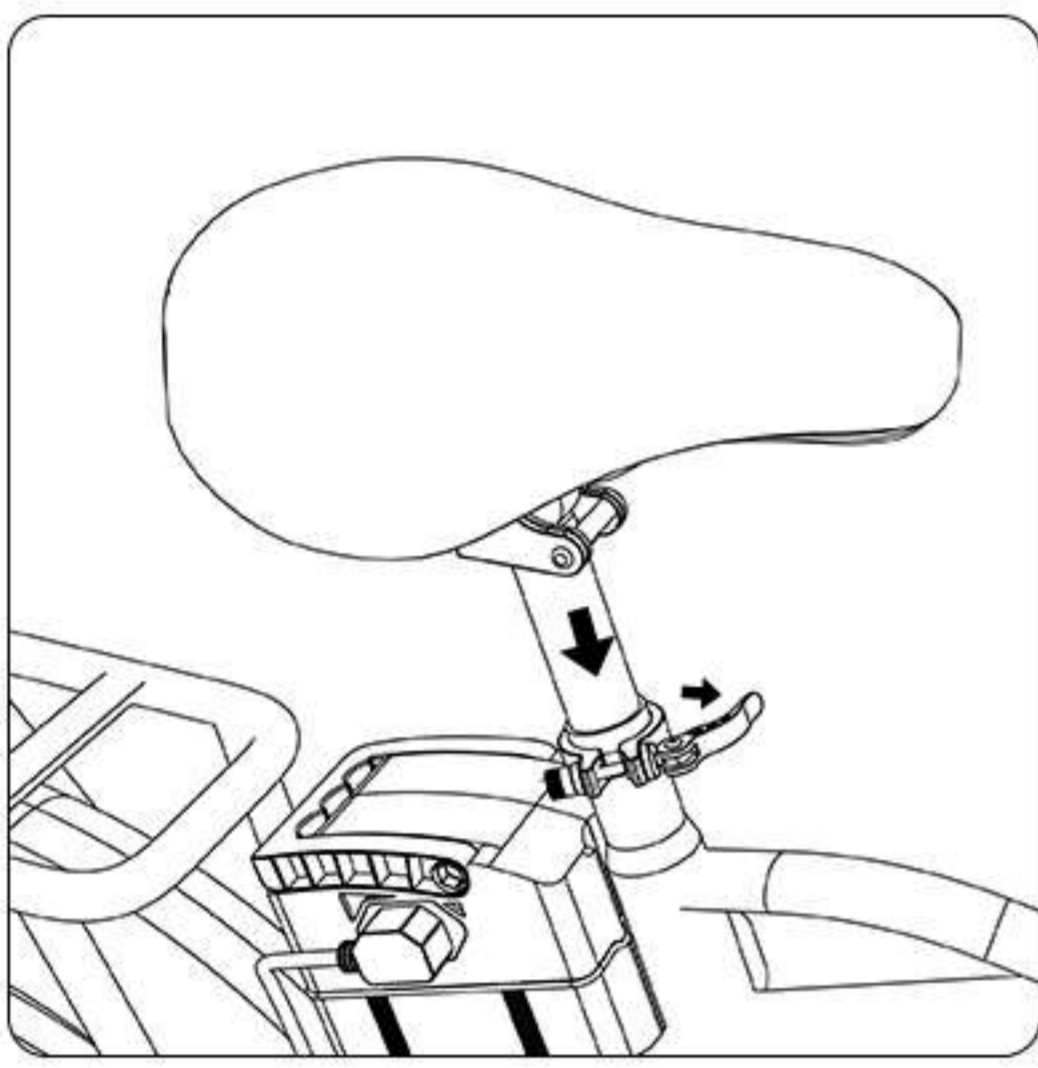

43. Release the quick-release seat post clamp to insert the seat post.

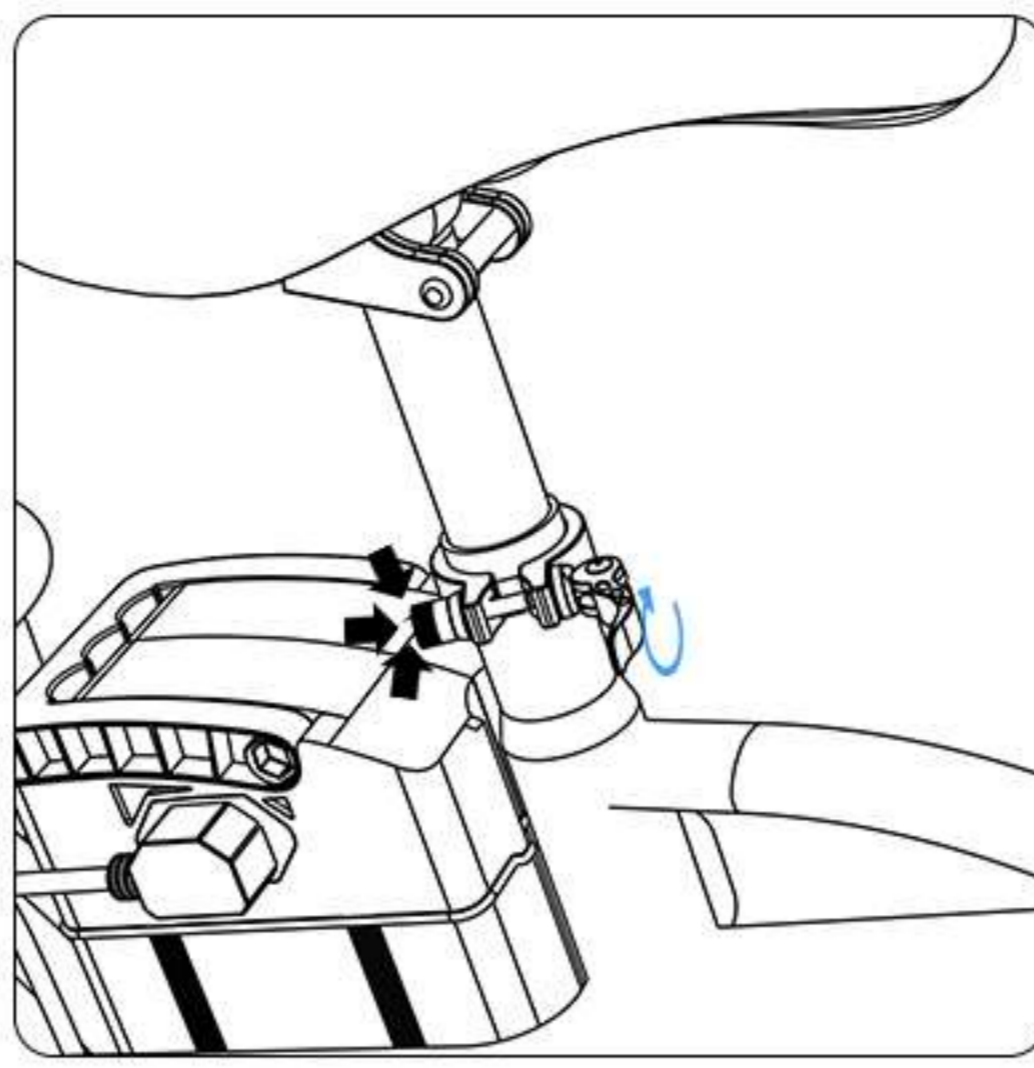

44. A quick fix for a slipping seat post is to rotate the quick-release lever in a clockwise direction. As it rotates, the adjusting nut should be kept still.

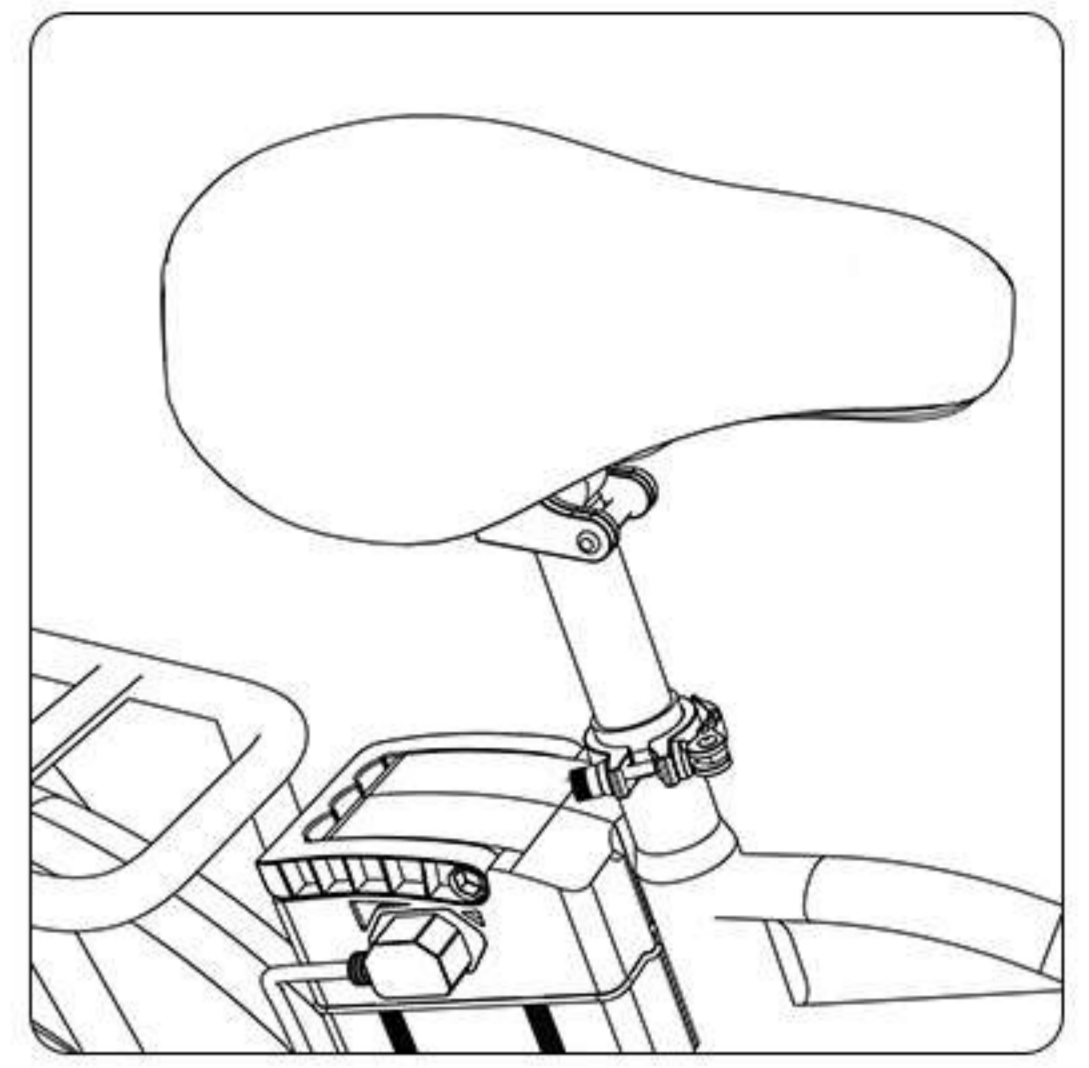

45. Raise or lower the seat post as needed, twist the saddle to a neutral position, and then fold the quick-release lever horizontally.

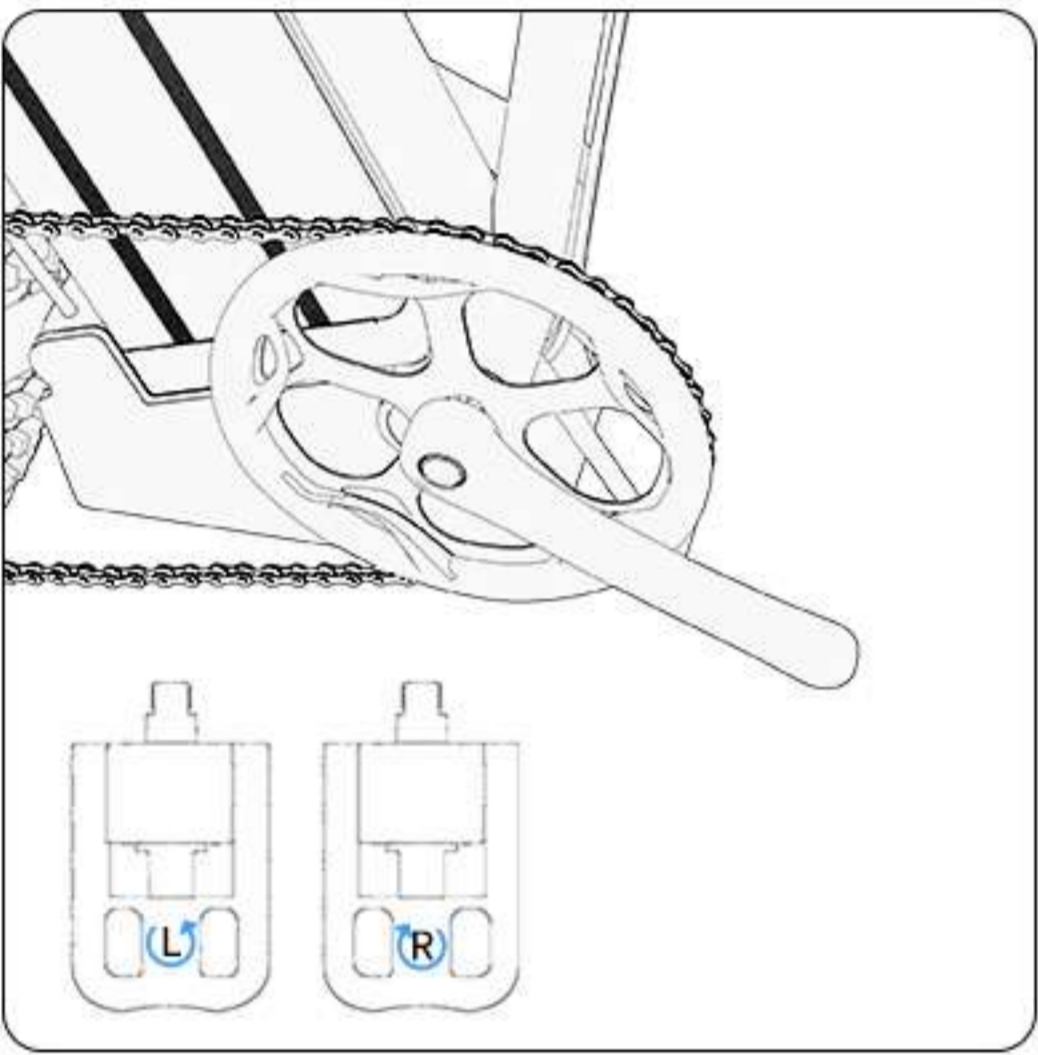

46. Note that the two pedals are oppositely threaded, so they should be tightened by turning in different directions.

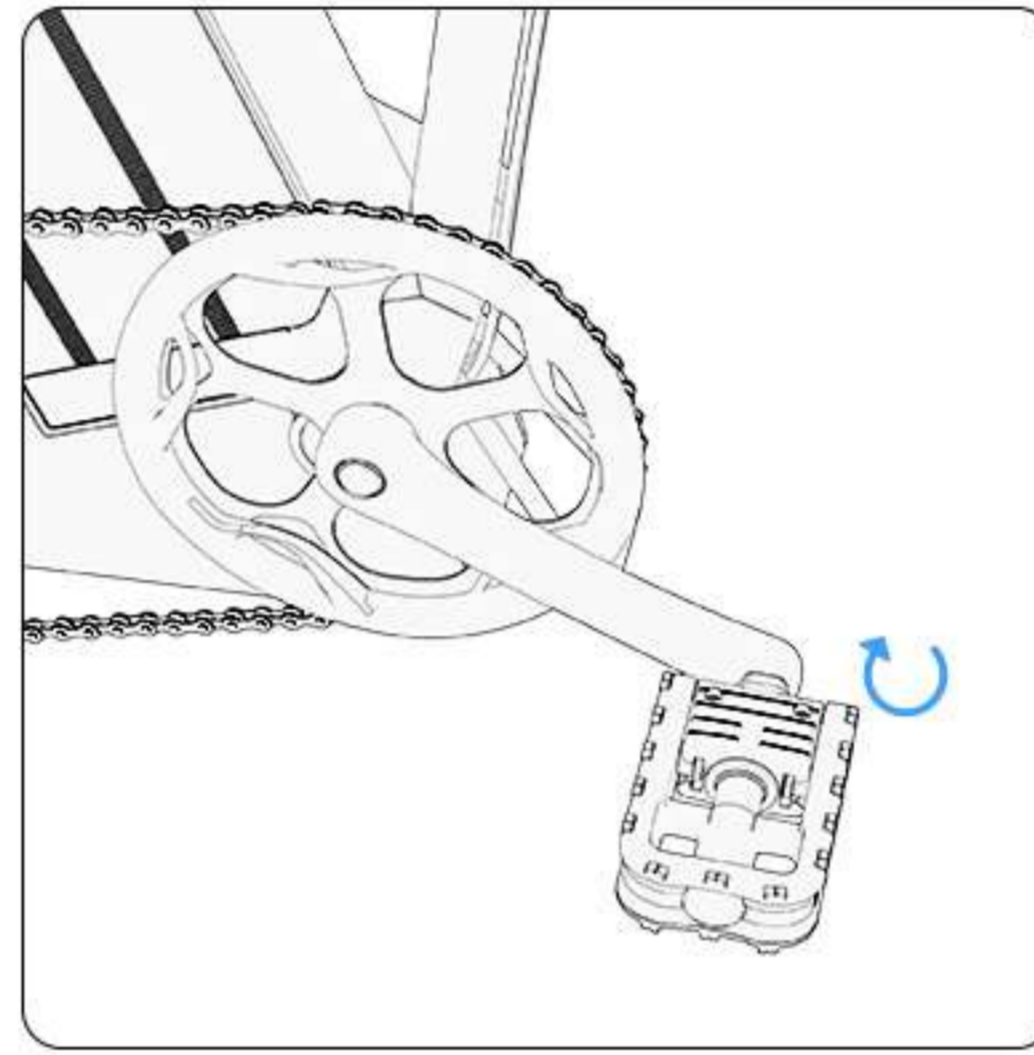

47. Install the right pedal onto the right-side crank arm by rotating it in a clockwise direction. Then use the 17mm wrench to tighten the right pedal.

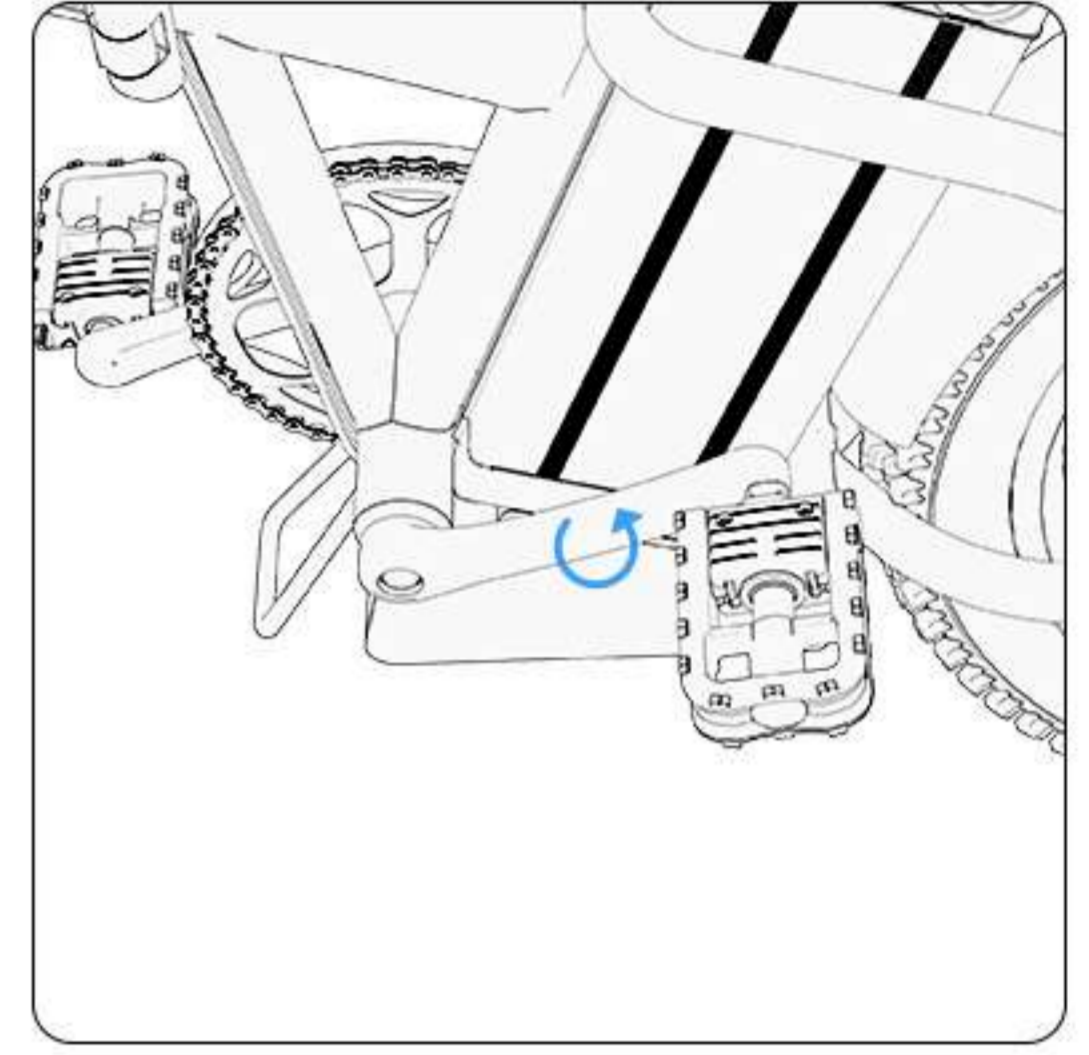

48. Counterclockwise rotate the pedal axle to attach it to the crank arm.

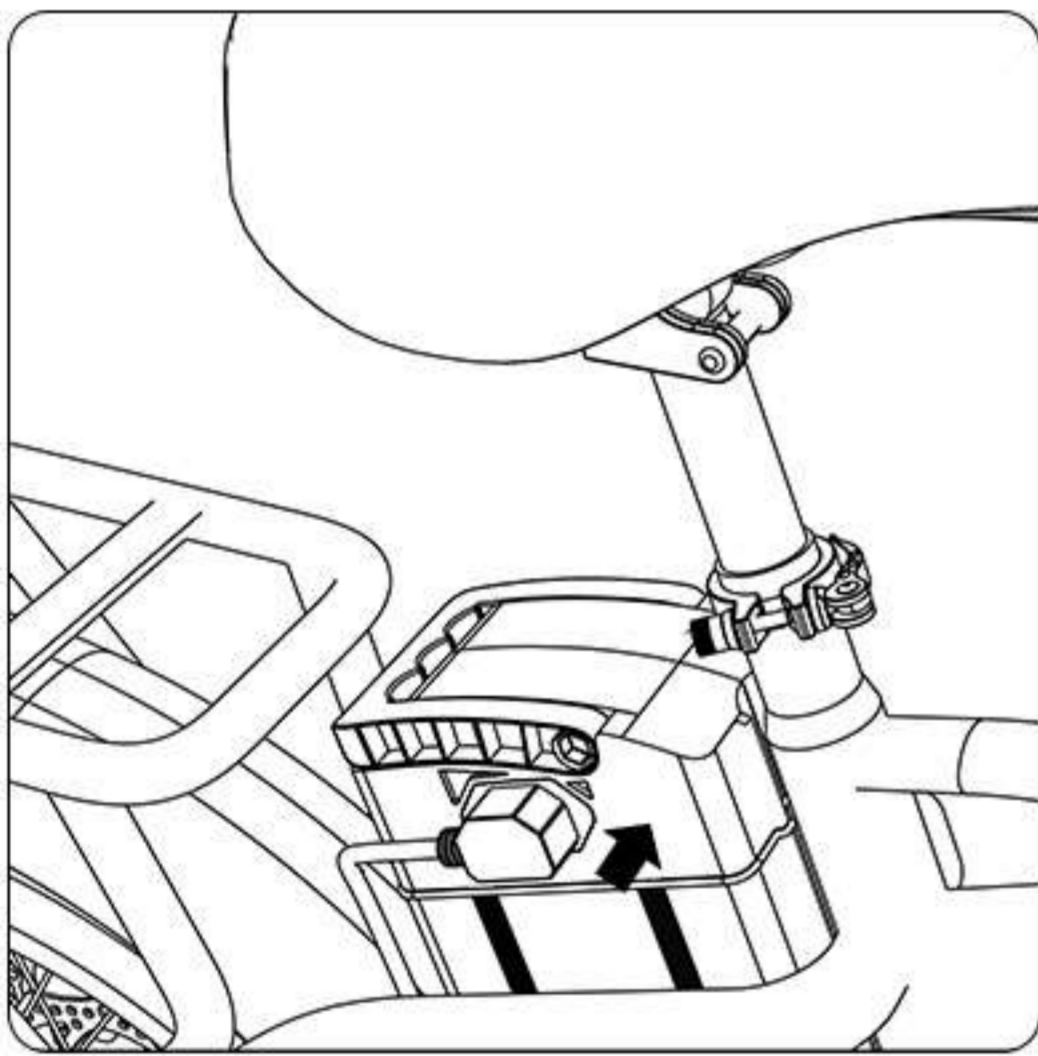

49. Locate the battery and plug in the 3-pin black plug.



Note: The recommended tire pressure range is 20-28PSI, with a peak pressure of 30PSI. you can choose the right tire pressure based on weight, terrain, and other factors.

FOLD YOUR BIKE UP

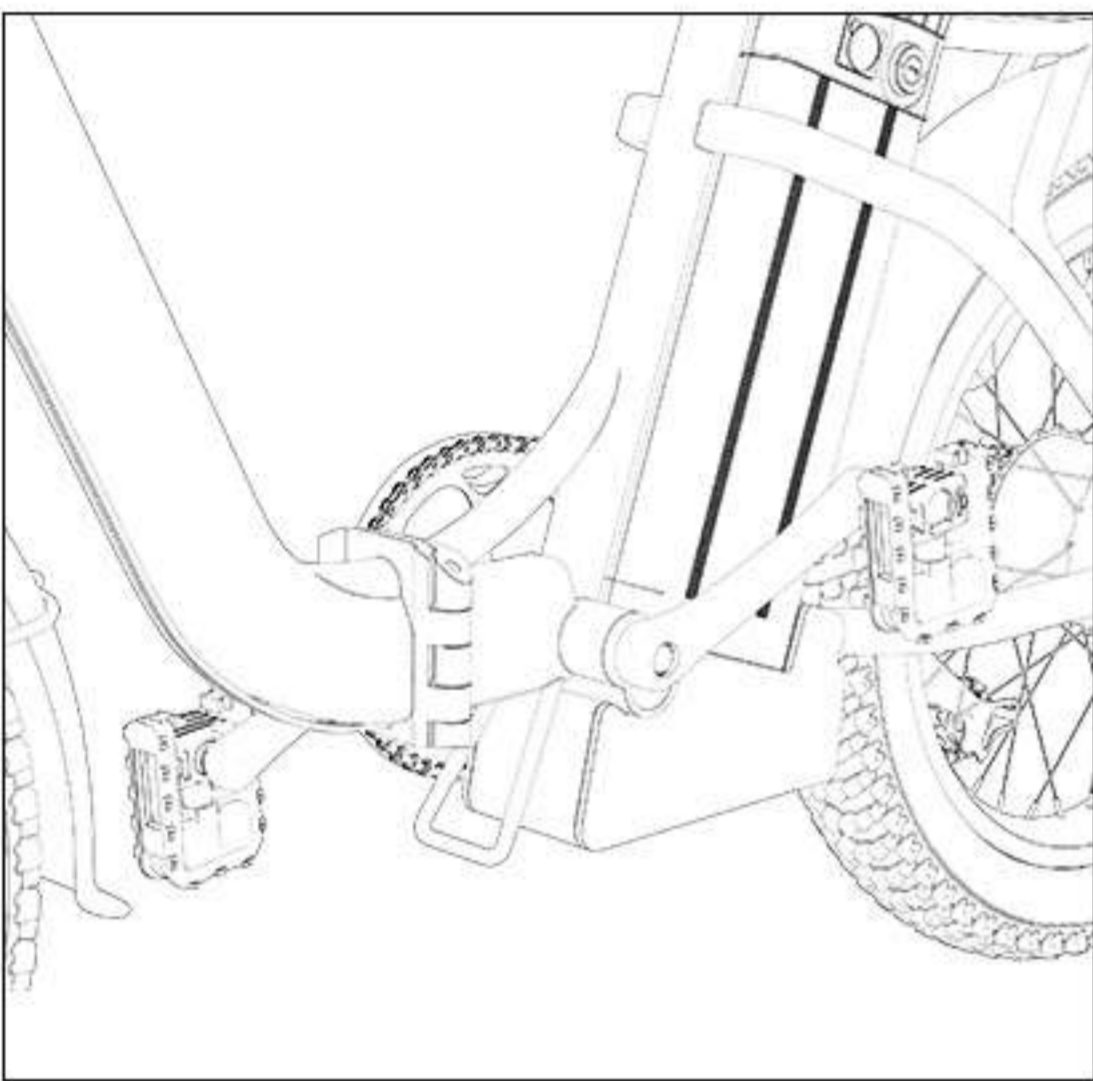
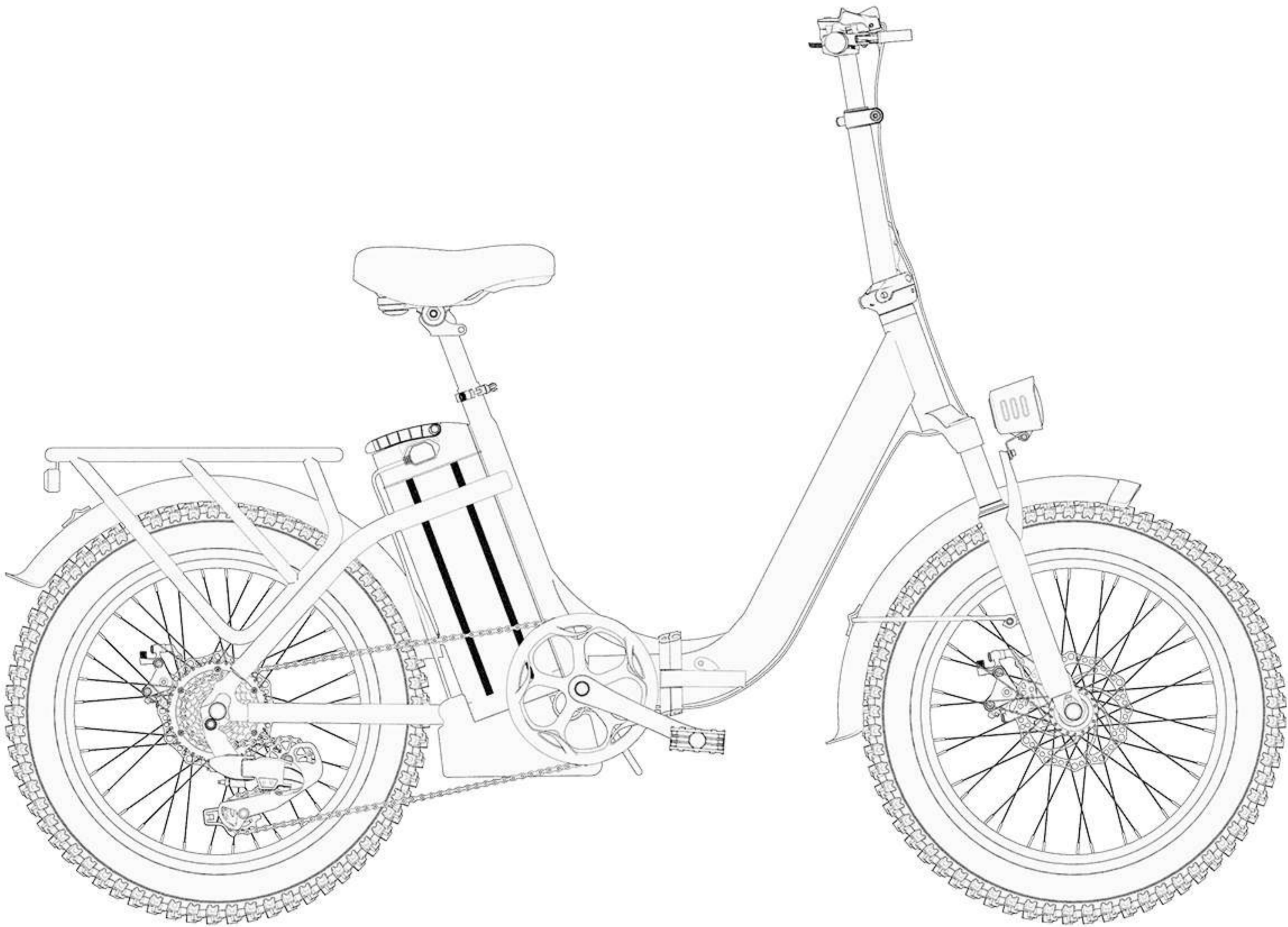

1. To fold the pedals, squeeze the pedal body (where the foot rest), and then fold them down.

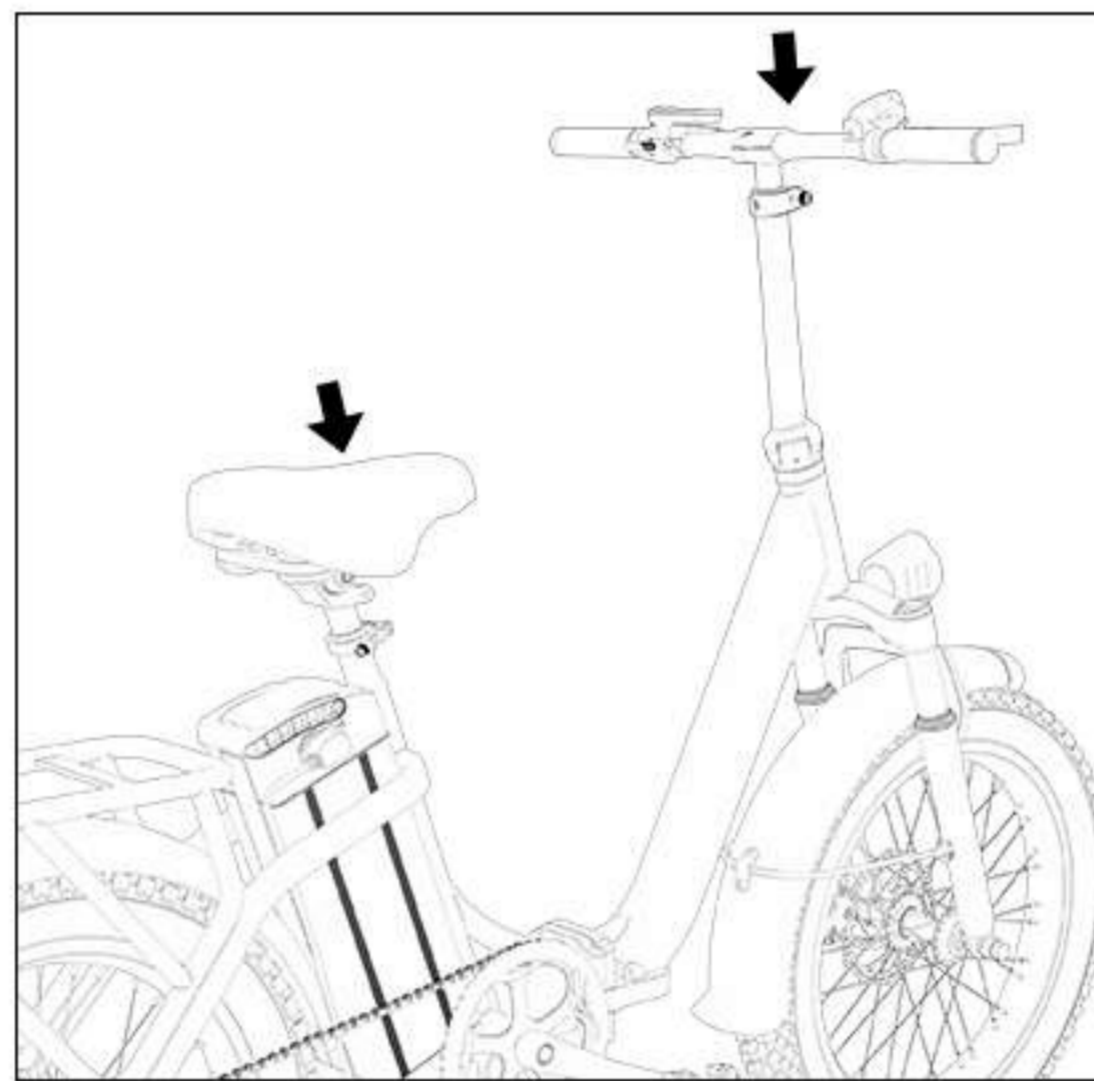

2. Release the quick-release clamps to adjust both the handlebar and seat height to the lowest.

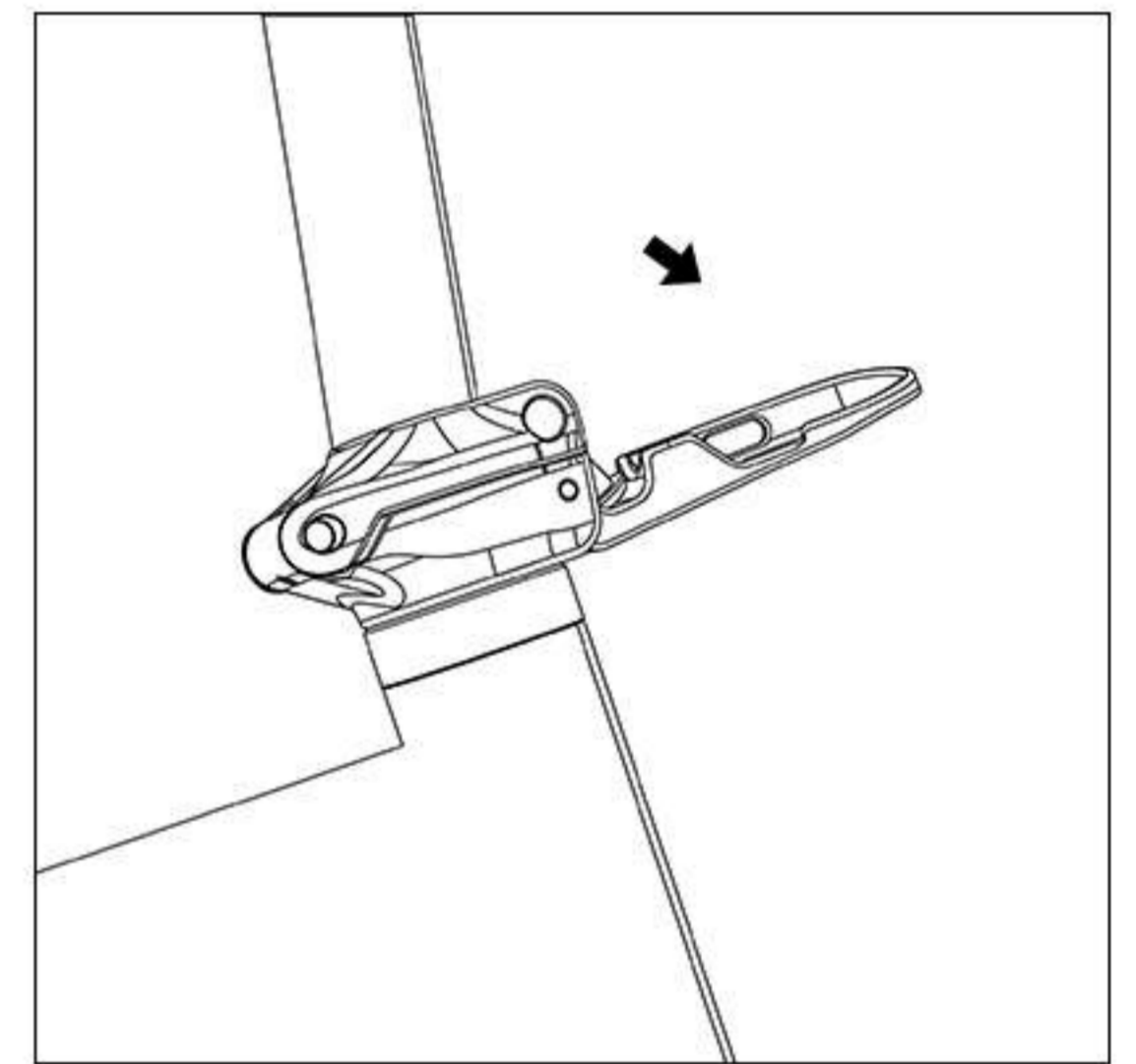

3. Anticlockwise tweak the safety collar and then unclamp the stem release lever.

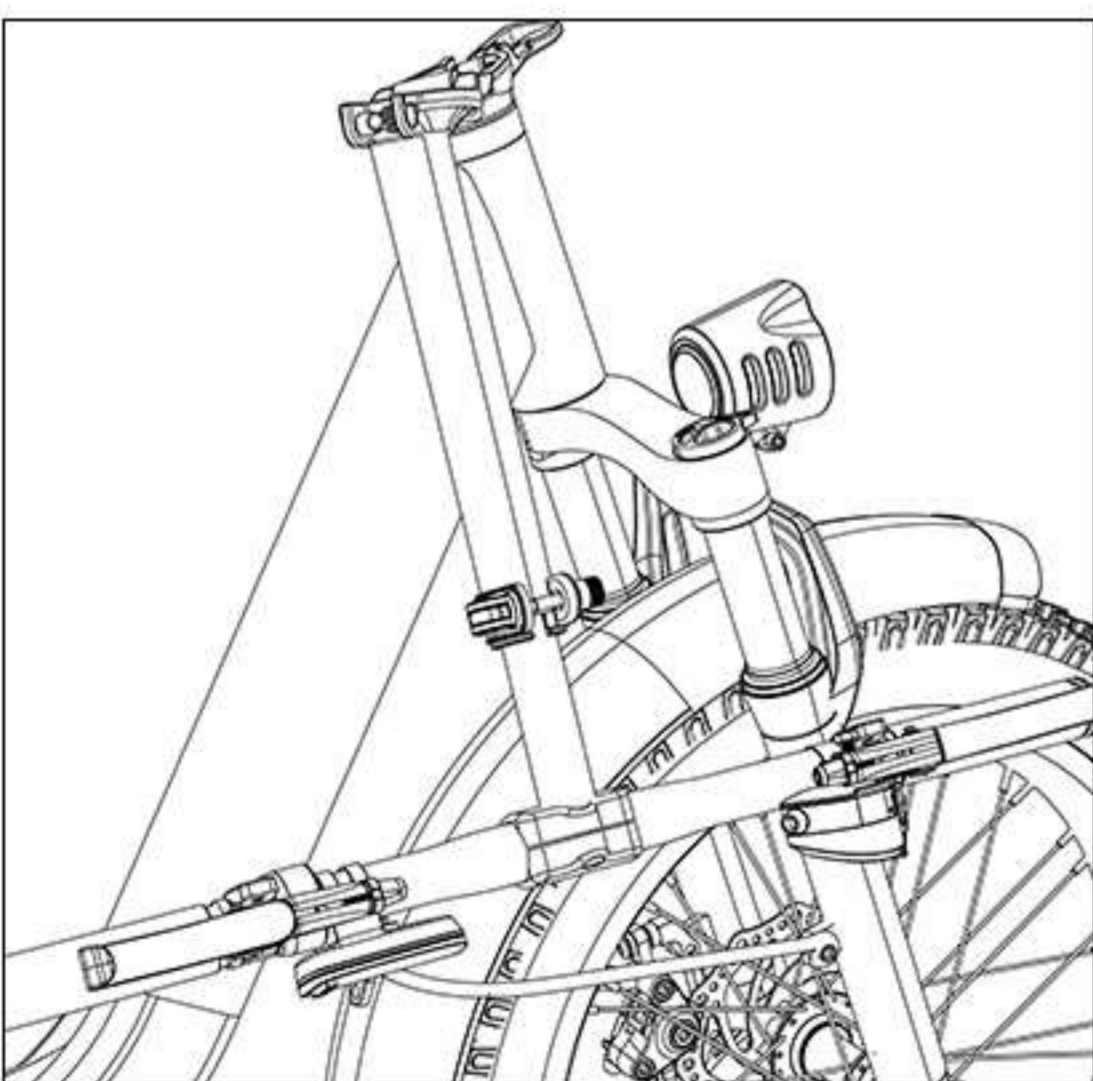

4. Then fold the folding stem up.

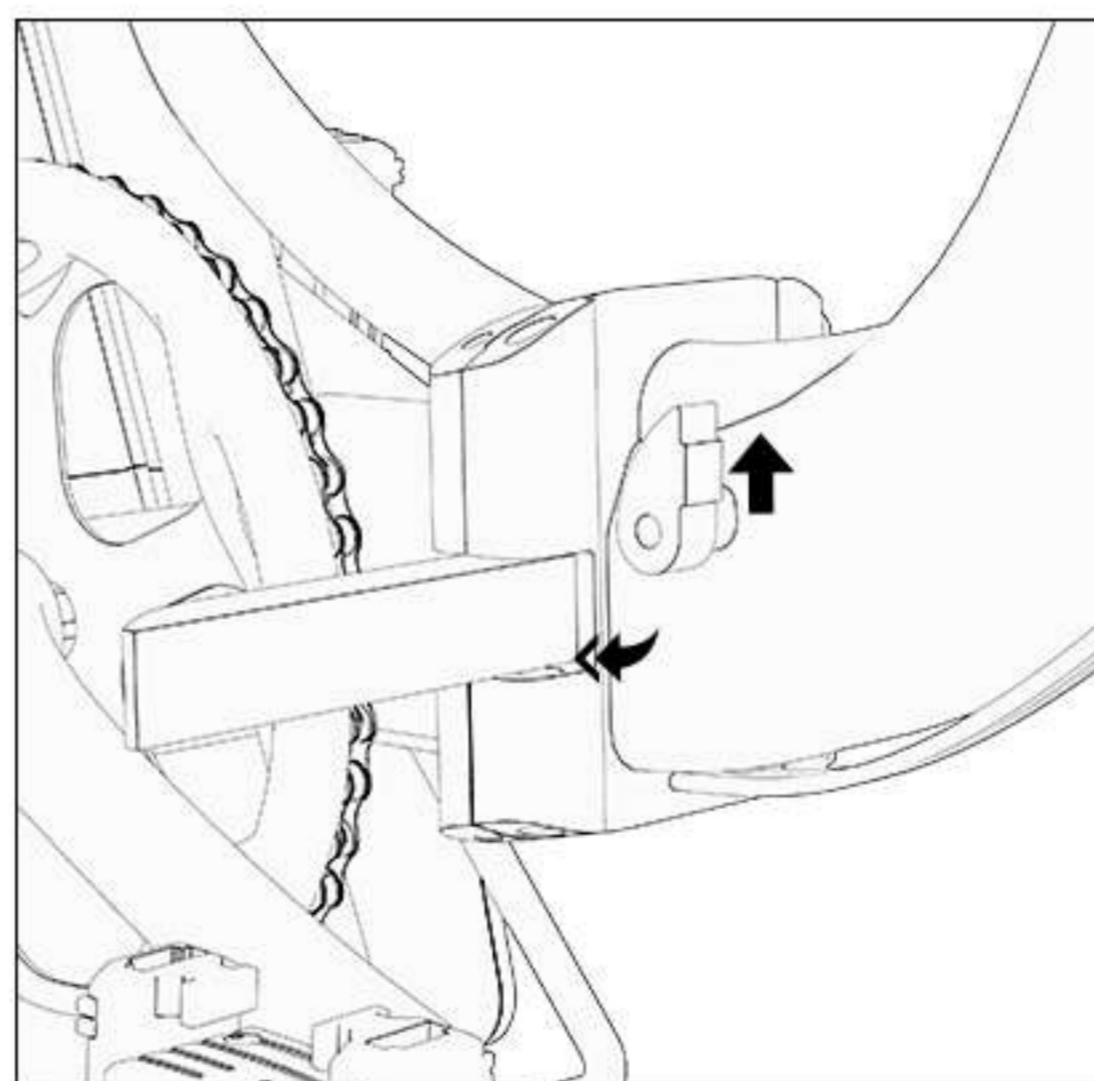

5. Open the small metal hook buckle to release the frame hinge lever. Then pull open the quick-release frame hinge lever to undo the frame hinge clamp.

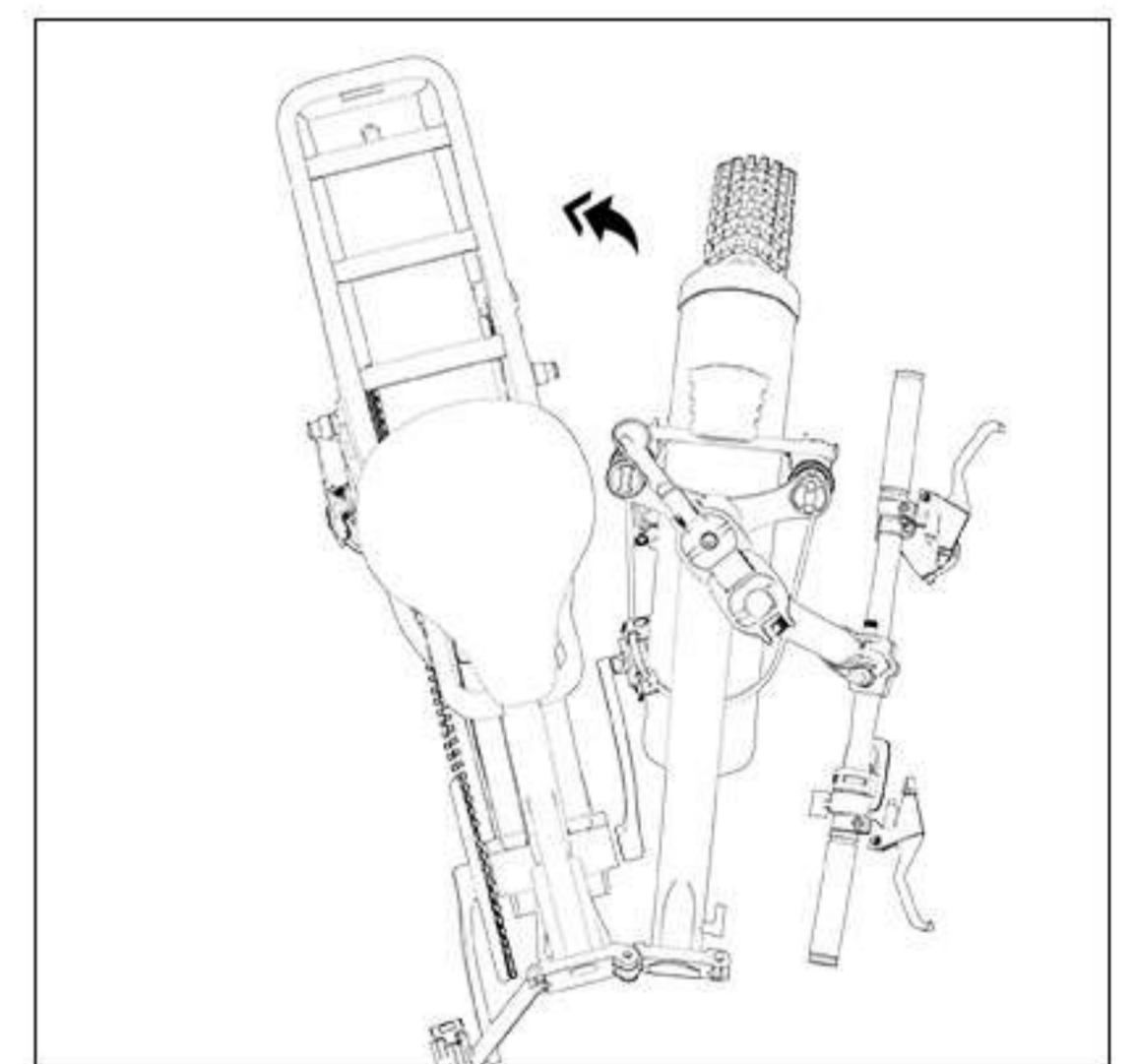

6. Release the kickstand. Grip the arc-shaped frame handle, and then slightly turn the front wheel to fold the mainframe.

REMOVE THE BATTERY

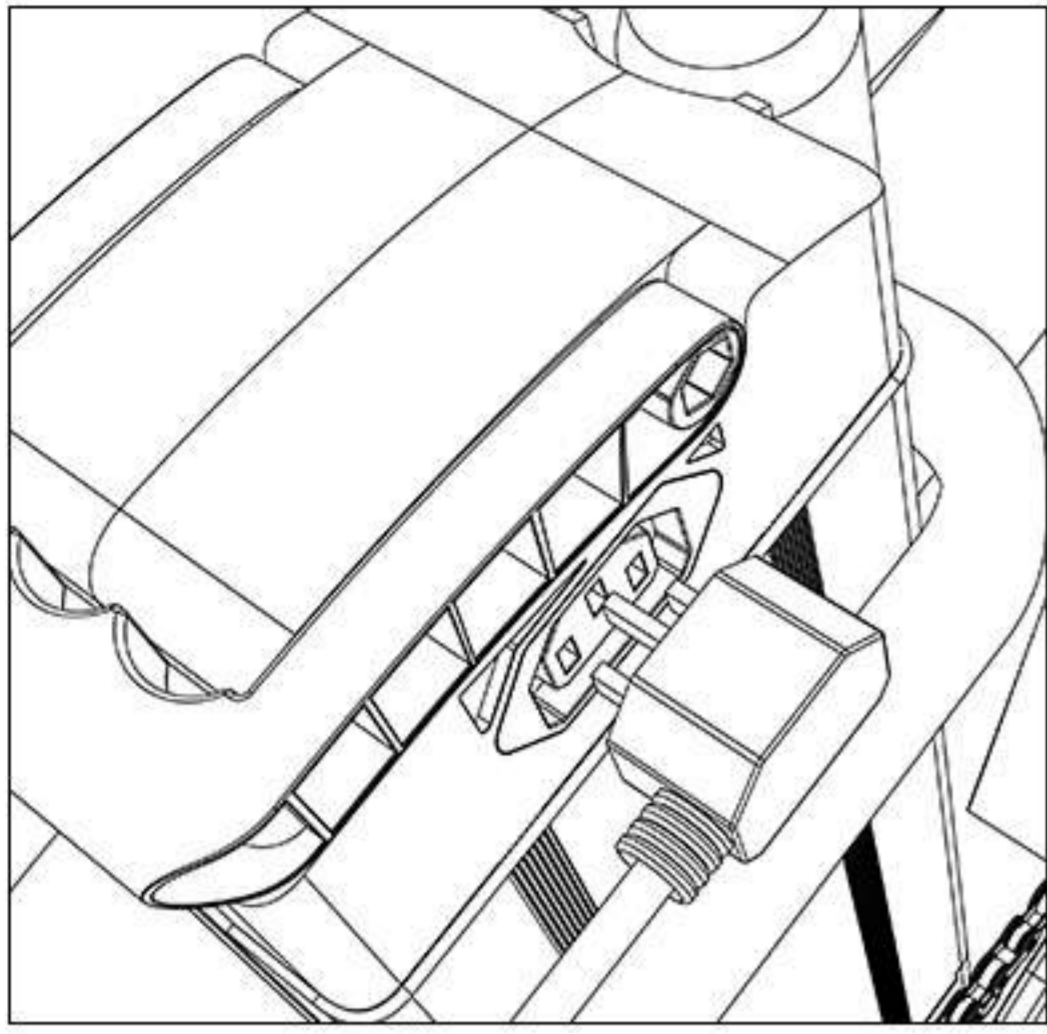

1. Unplug the power cord.

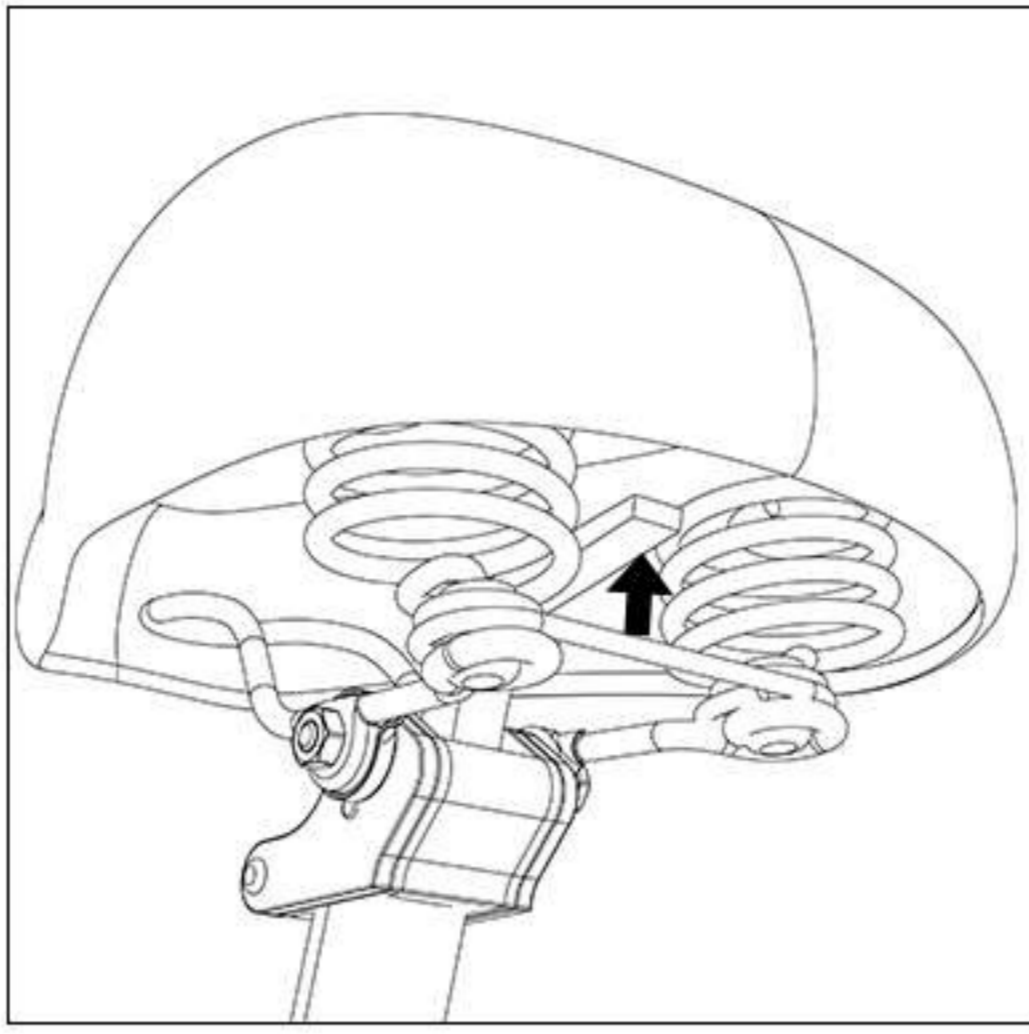

2. Pull the release lever underneath the saddle.

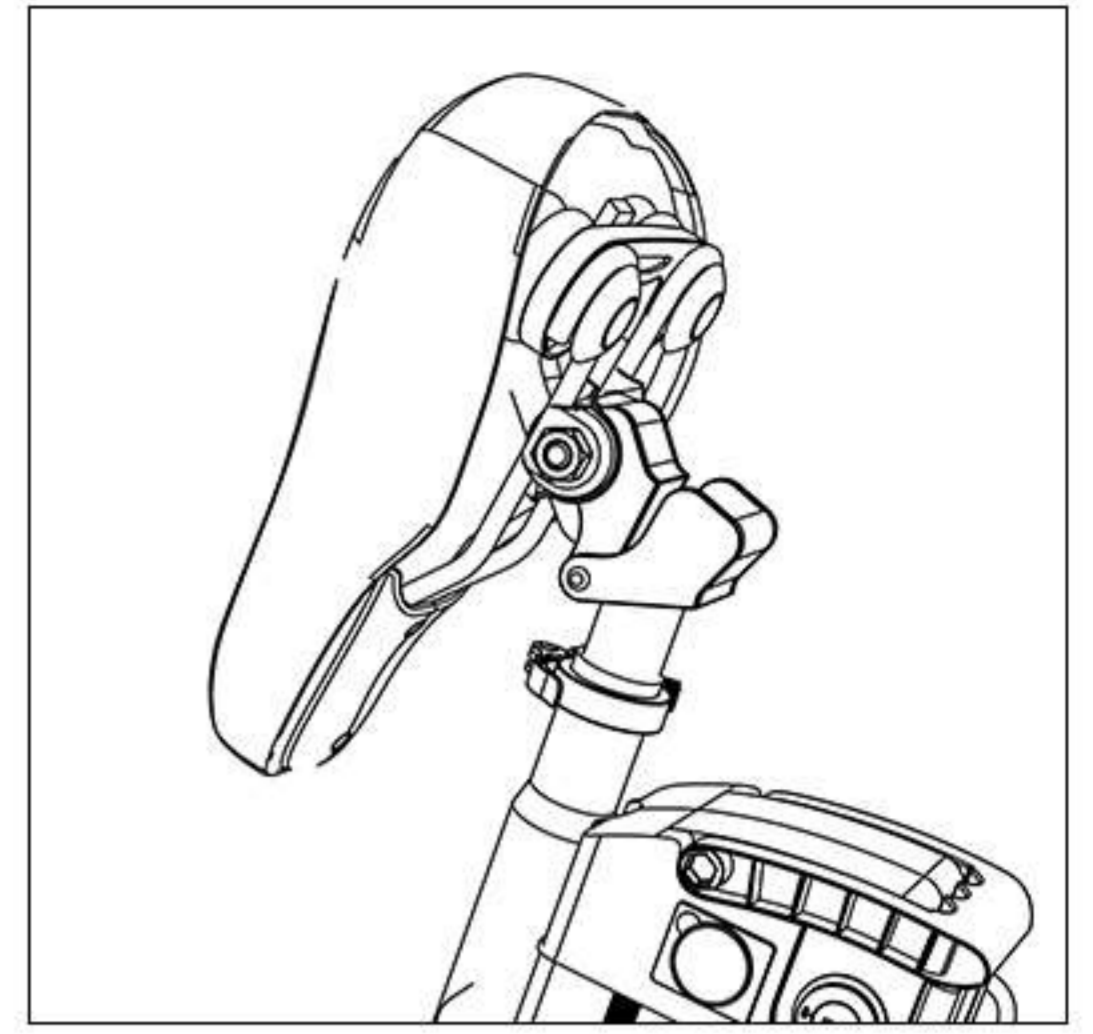

3. You'll be able to fold the saddle up.

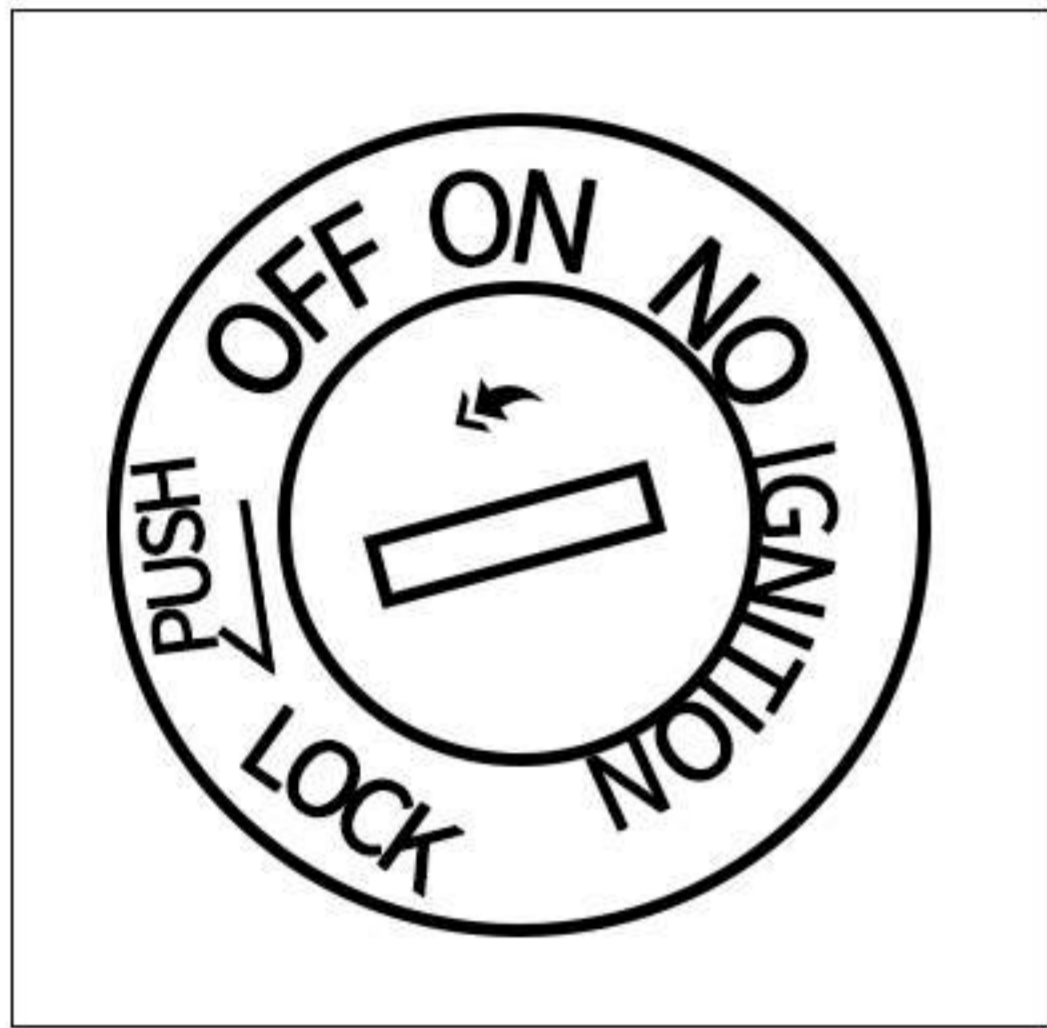

4. Anti-clockwise turn the key from the "ON" position to the "OFF", then push inward to reach the "UNLOCK" position.

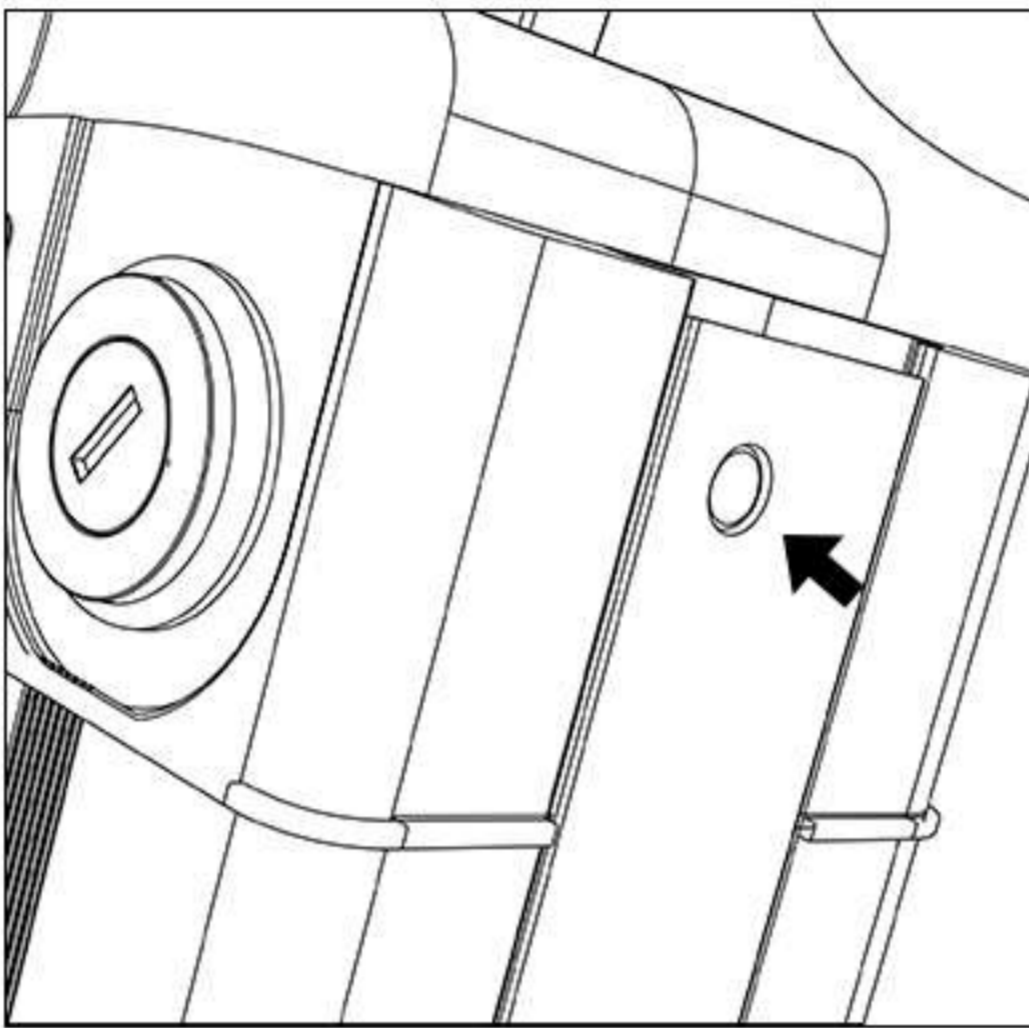

5. Once unlocked, the lock pin retracts into the battery.

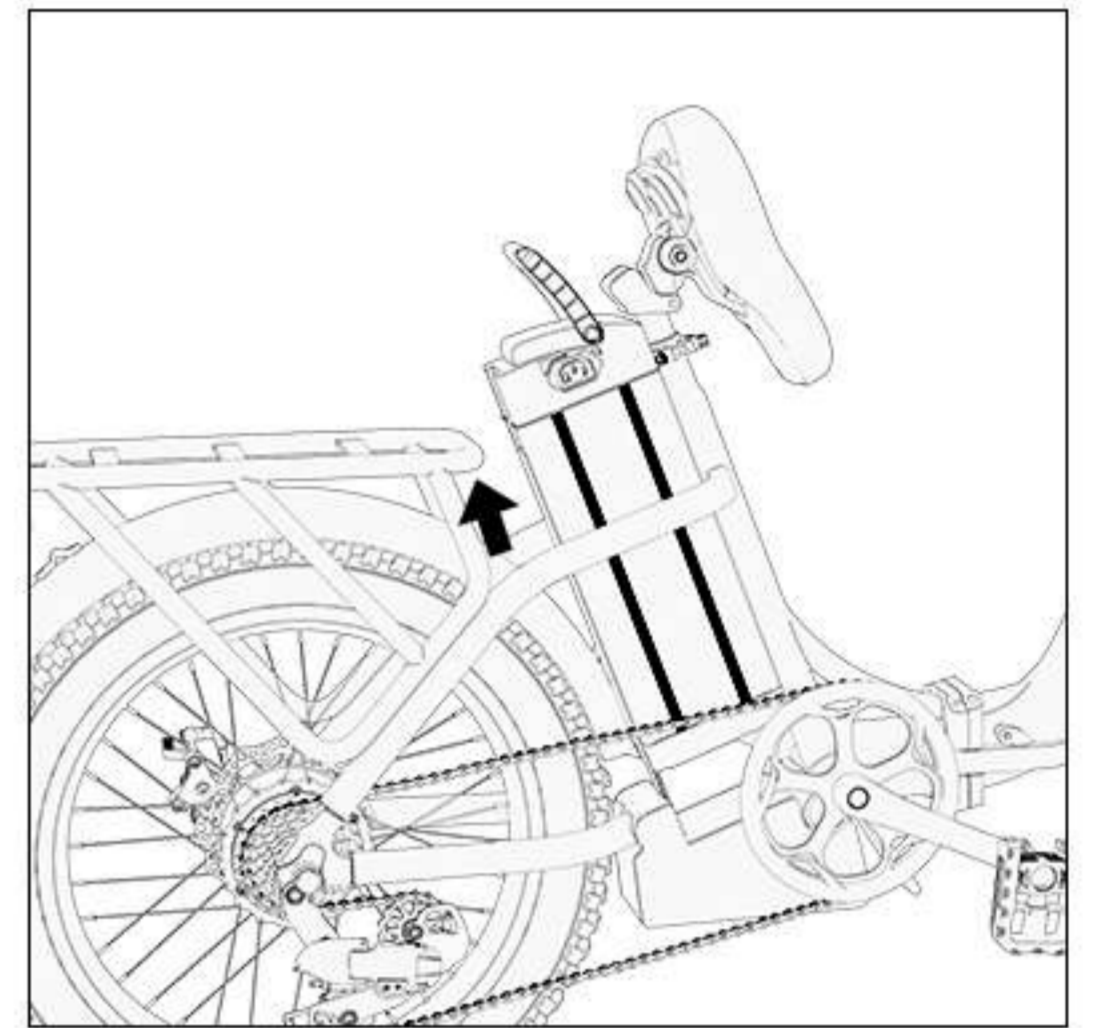

6. Vertically pull the pull ring mounted on the top of the battery to remove the battery from the sliding tracks.

INSTALLED BATTERIES

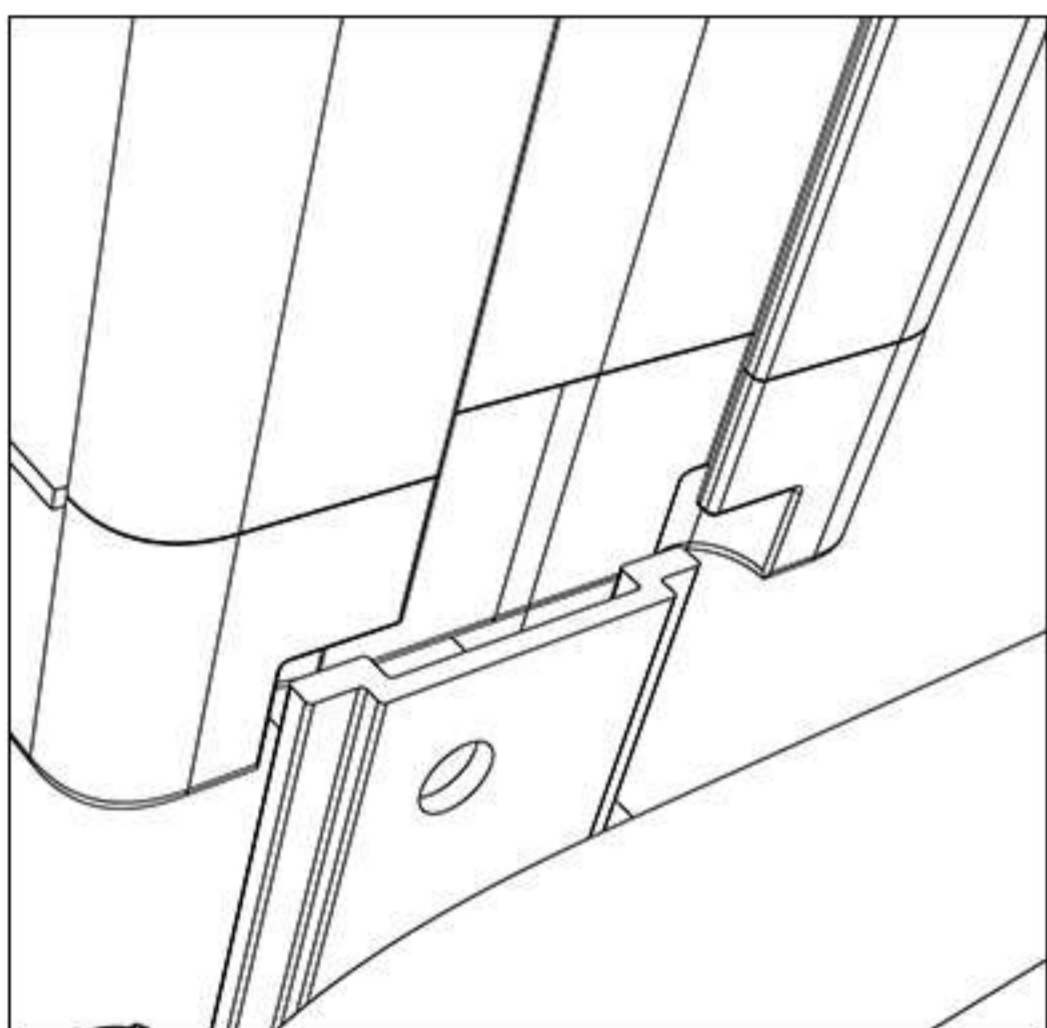

1. To install the battery, insert the sliding tracks into the grooves at the back of the battery.

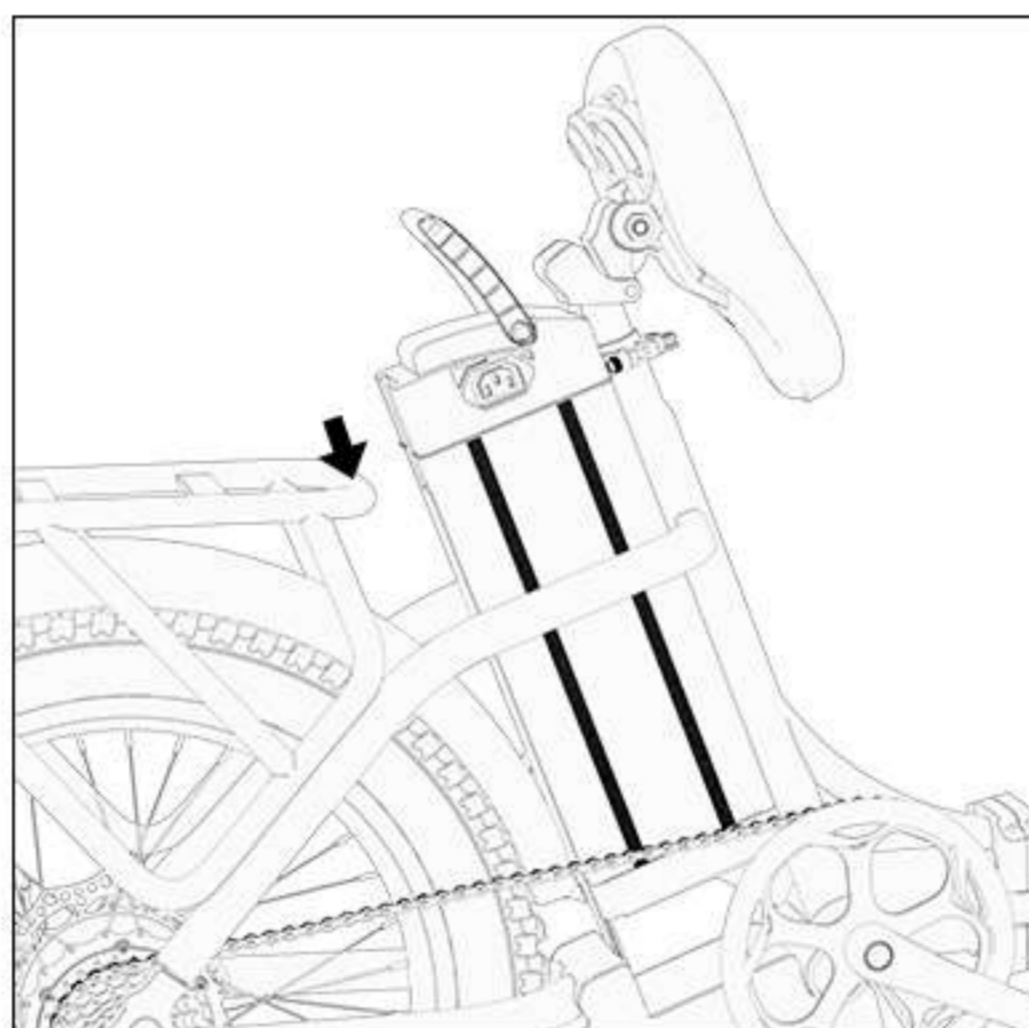

2. Slide the battery up and down to check whether it is placed correctly.



3. Insert the key, and turn it in a clockwise direction twice to lock the battery into place.

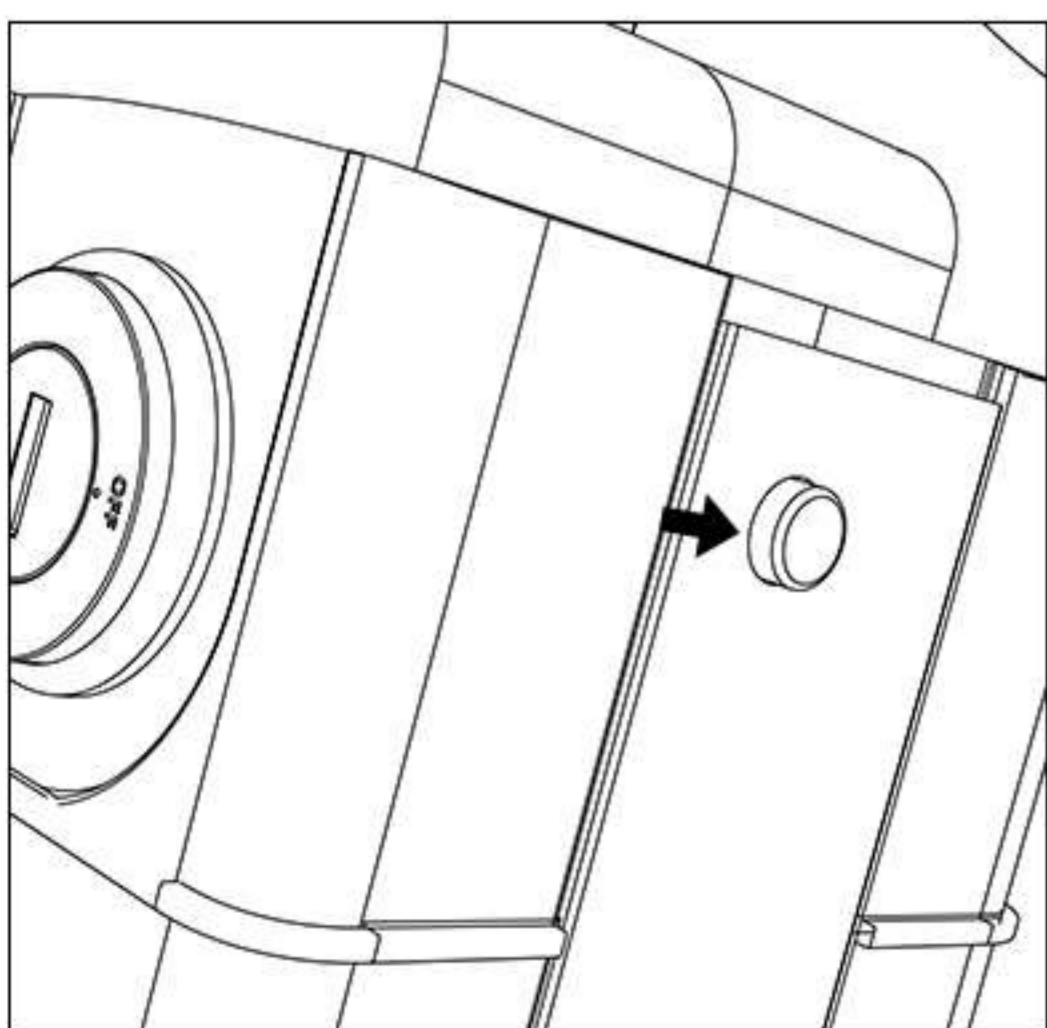

4. Once locked, the lock pin passes through the hole.

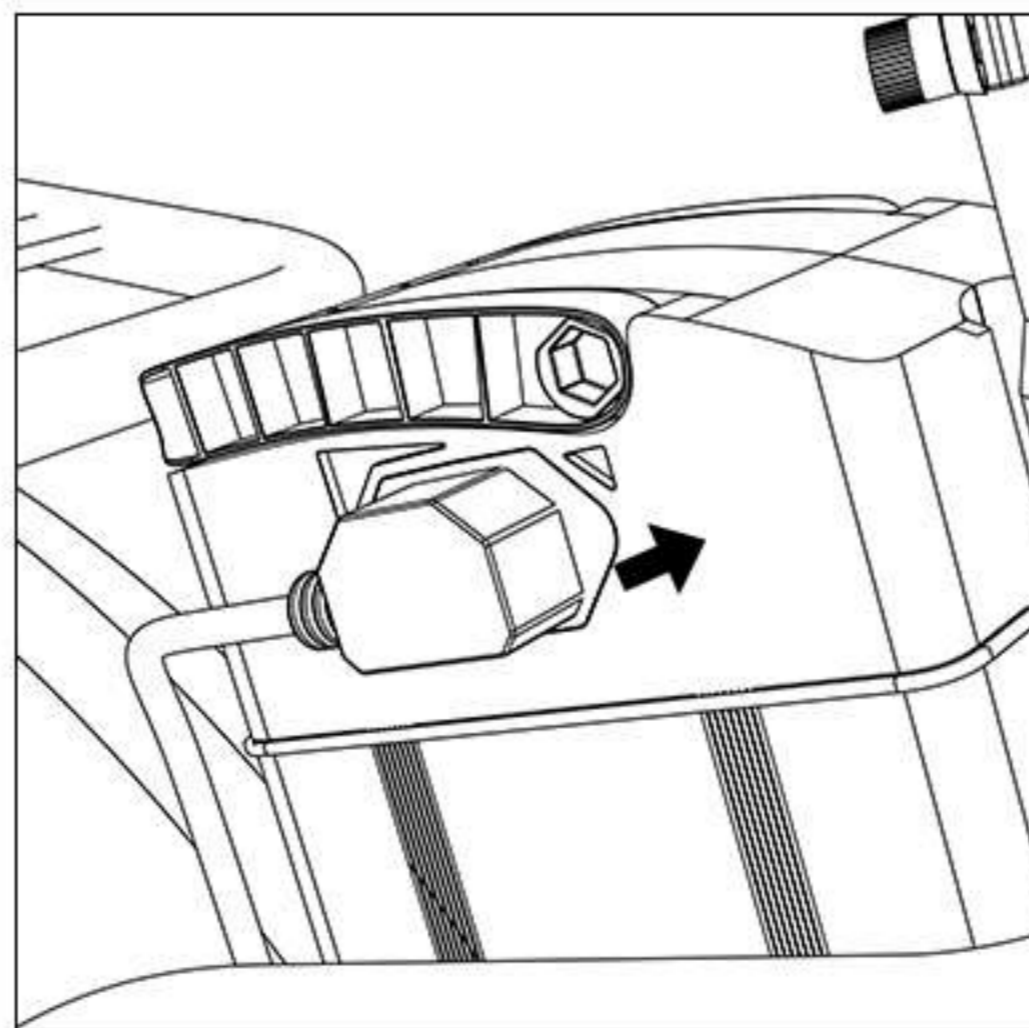

5. Then plug in the power cord.

HOW TO ADJUST THE SEAT HEIGHT

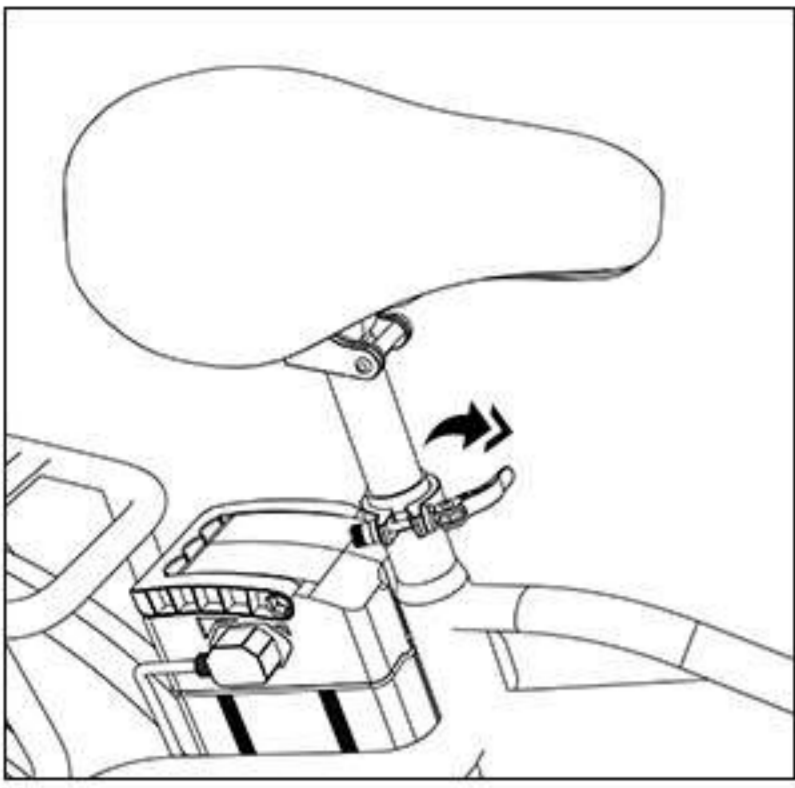

1. Release the quick-release seat post clamp.

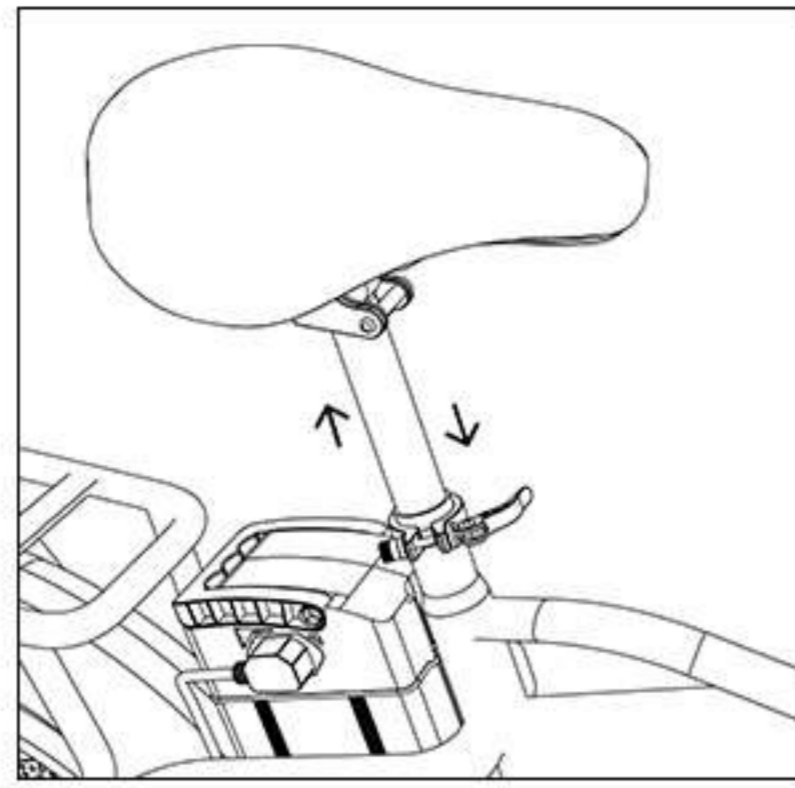

2. Raise or lower the seat post as needed.

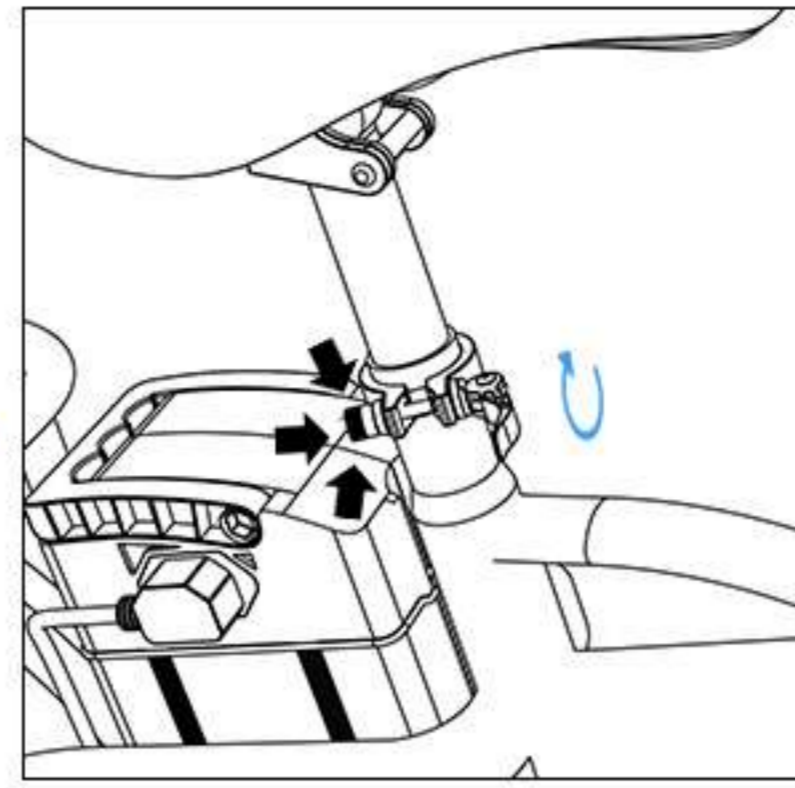

3. Clockwise rotate the quick-release lever with one hand holding the adjusting nut.

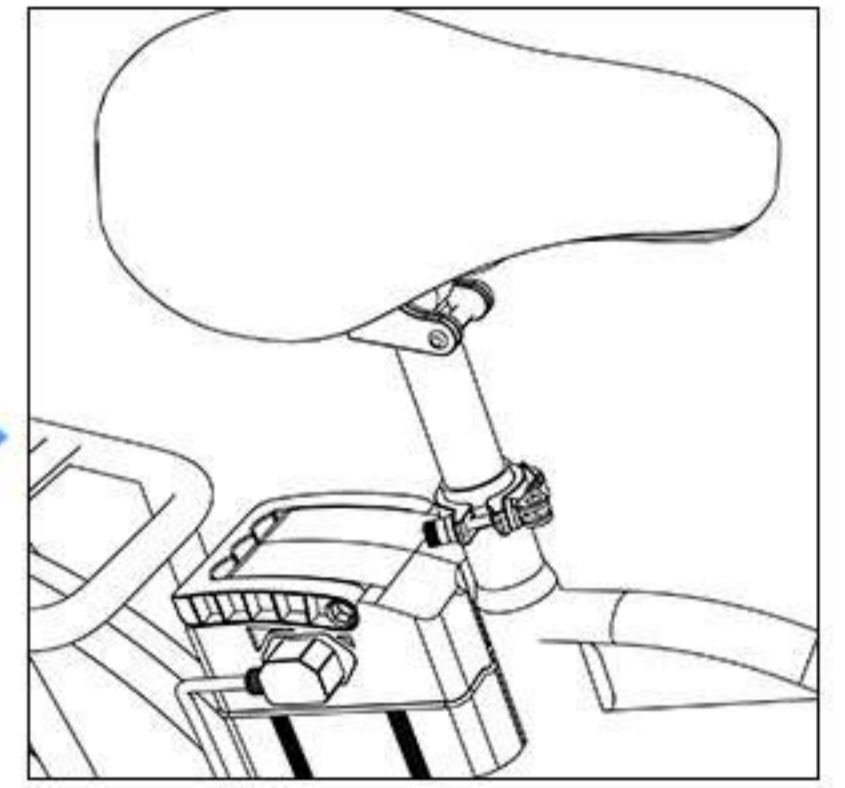

4. Close the lever to check whether the stem is securely locked in place.

HOW TO ADJUST THE HEIGHT OF THE HANDLEBAR

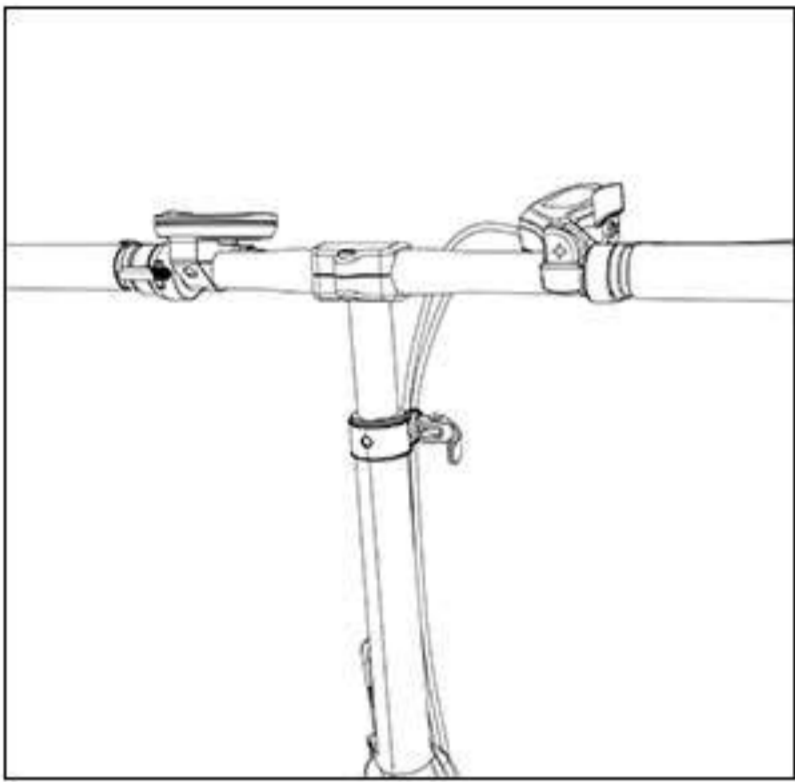

1. Open the quick-release lever.

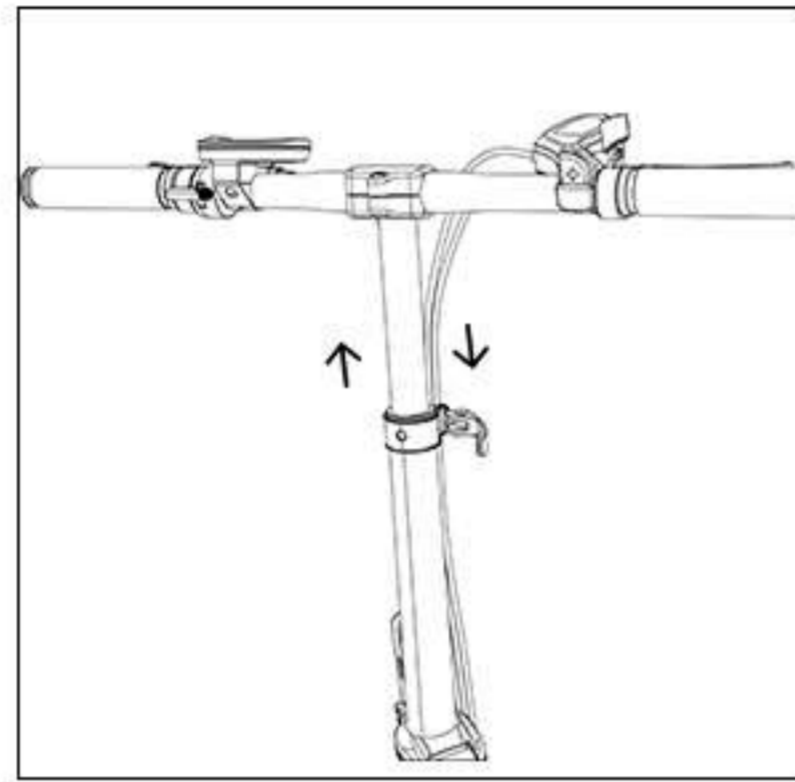

2. Telescope the stem for handlebar height adjustment.

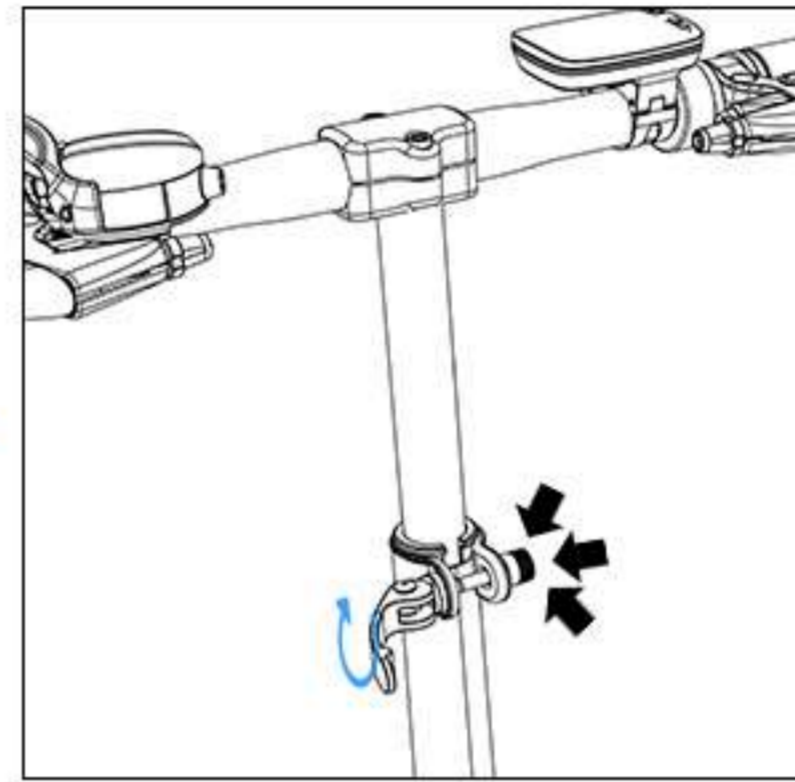

3. Clockwise rotate the quick-release lever with one hand holding the adjusting nut.

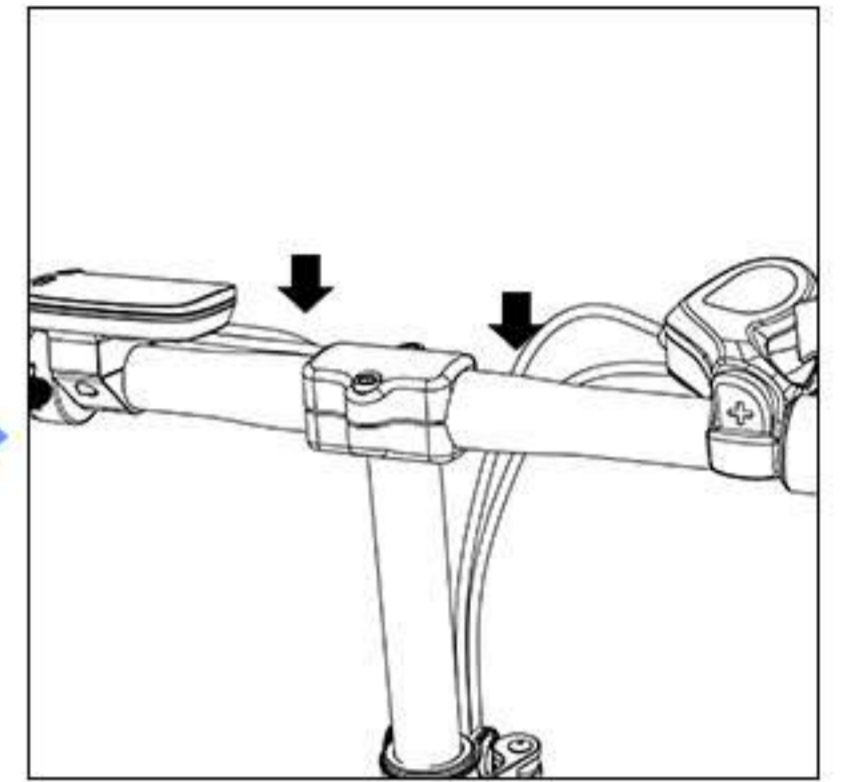

4. Close the lever to check whether the stem is securely locked in place.



Note: When adjusting the height of the seat and handle, the position of the dotted line marked on the body of the tube must not be exceeded

HOW TO CHARGE

SOHAMO provides you with both whole bike charging and external battery charging for your convenience to choose.

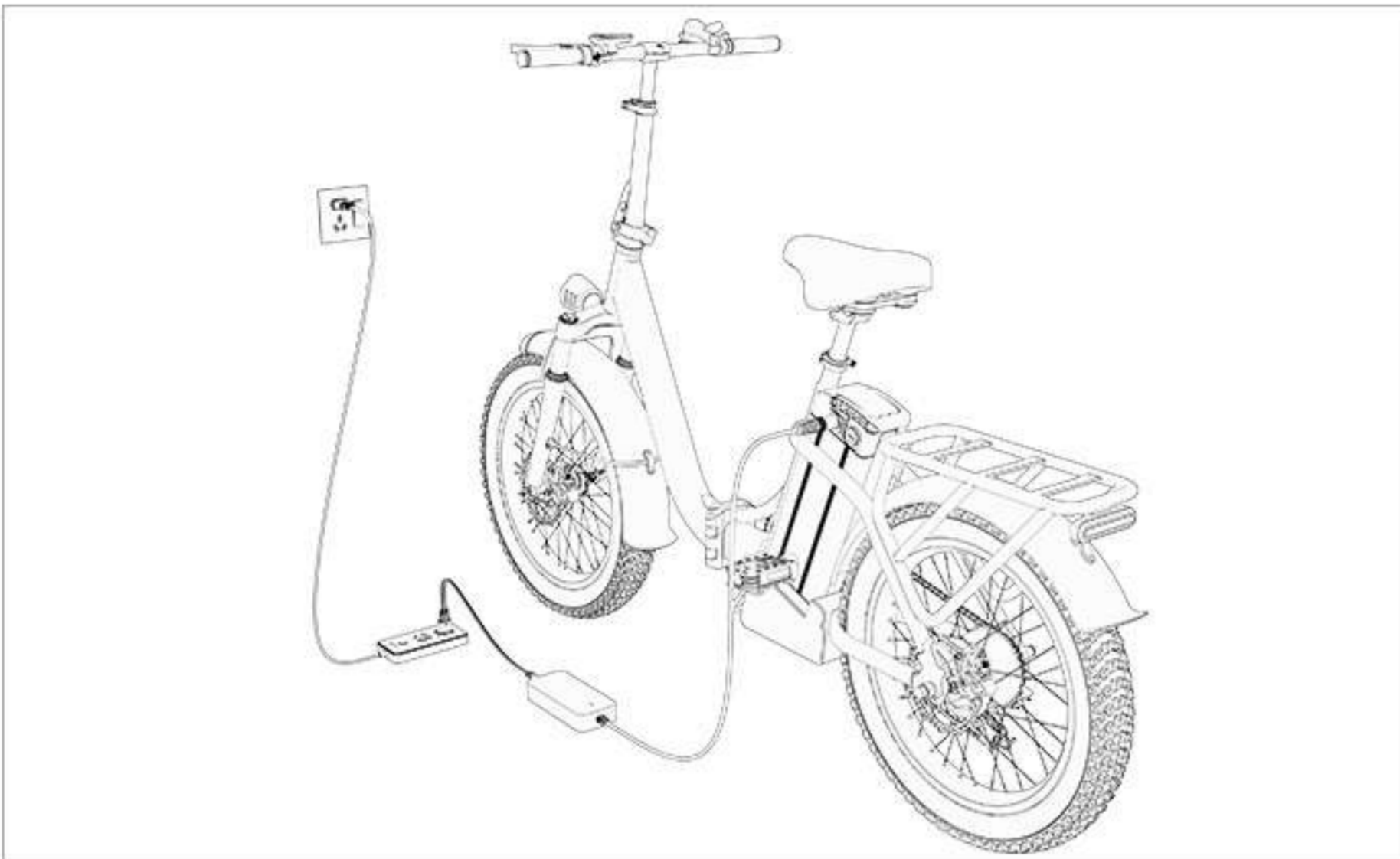

Whole bike charging mode:

You can plug the charging plug into the body charging port and charge the E-Bike directly.

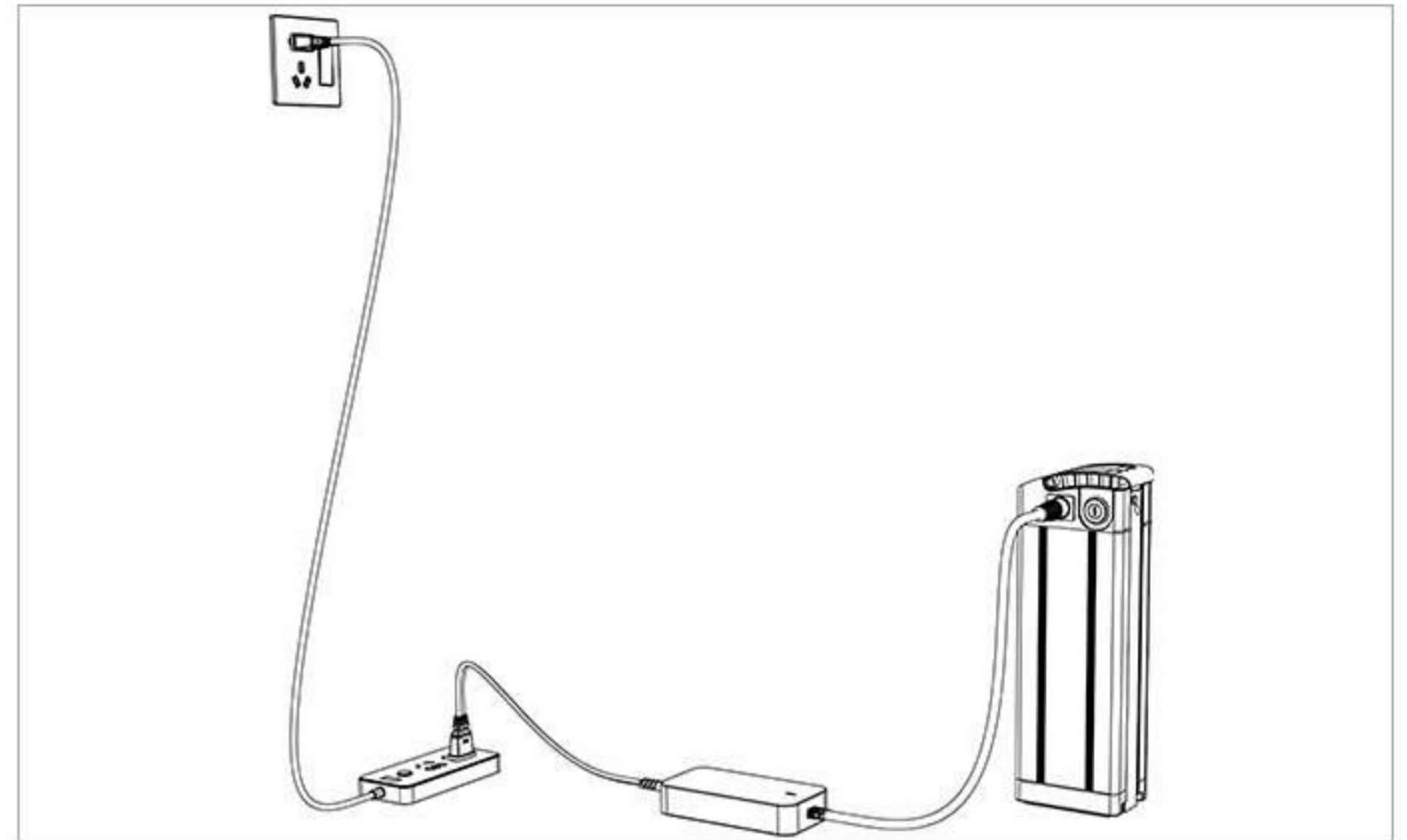

External charging mode:

Remove the battery and you can plug the charging plug into the battery charging port for external charging.



CHARGING SAFETY

- Do not use a charger other than SOHAMO to charge the E-Bike.
- When you receive the E-Bike, please charge the battery for the first time in time to ensure that the battery is fully charged when you ride it for the first time.
- Do not leave the battery unattended while charging.
- Avoid charging the battery at too high a temperature.
- Make sure there are no flammable objects around when charging.

Battery Safety:

- ⊘ If you find the battery is damaged, leaking, discolored, etc., please do not charge the battery.
- ⊘ When storing the battery, be sure to keep it away from heat sources and avoid direct sunlight.
- ⊘ Do not immerse the battery in any liquid.
- ⊘ Do not force the battery to remove, follow the instruction manual into the removal of the battery.
- ⊘ Battery charging time may increase depending on the time of use.
- ⊘ If the battery fails to charge, stop charging immediately.

Caution:

Be careful when charging, misuse will lead to property damage and personal injury

When your batteries are no longer in use, dispose of your batteries according to your local state regulations. Disposal regulations for lithium batteries vary from state to state, so it is important to know your local government's regulations. Lithium batteries should not be placed with regular trash.

INSTRUMENT INTRODUCTION

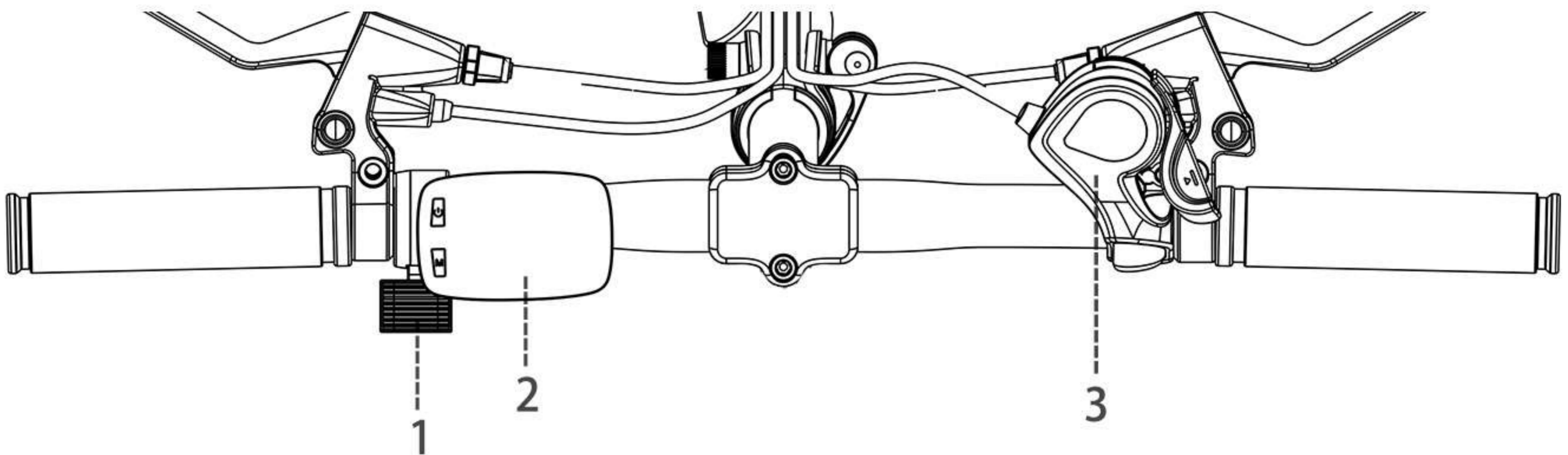

1. Thumb throttle

2. Display

3. Thumb shifter



Caution:

The display should be carefully protected from physical damages and scratches. For normal use, it is not recommended to modify the default parameters/menu that are not explained in this manual.

ON/OFF METER

Turn Your Bike On

1. Insert the battery key and turn it from the OFF position to the ON. It activates the battery to provide energy for the whole electrical system. (i.e. stand-by state)
2. Next, press and hold down the “POWER” button on the LED display to turn your bike on.

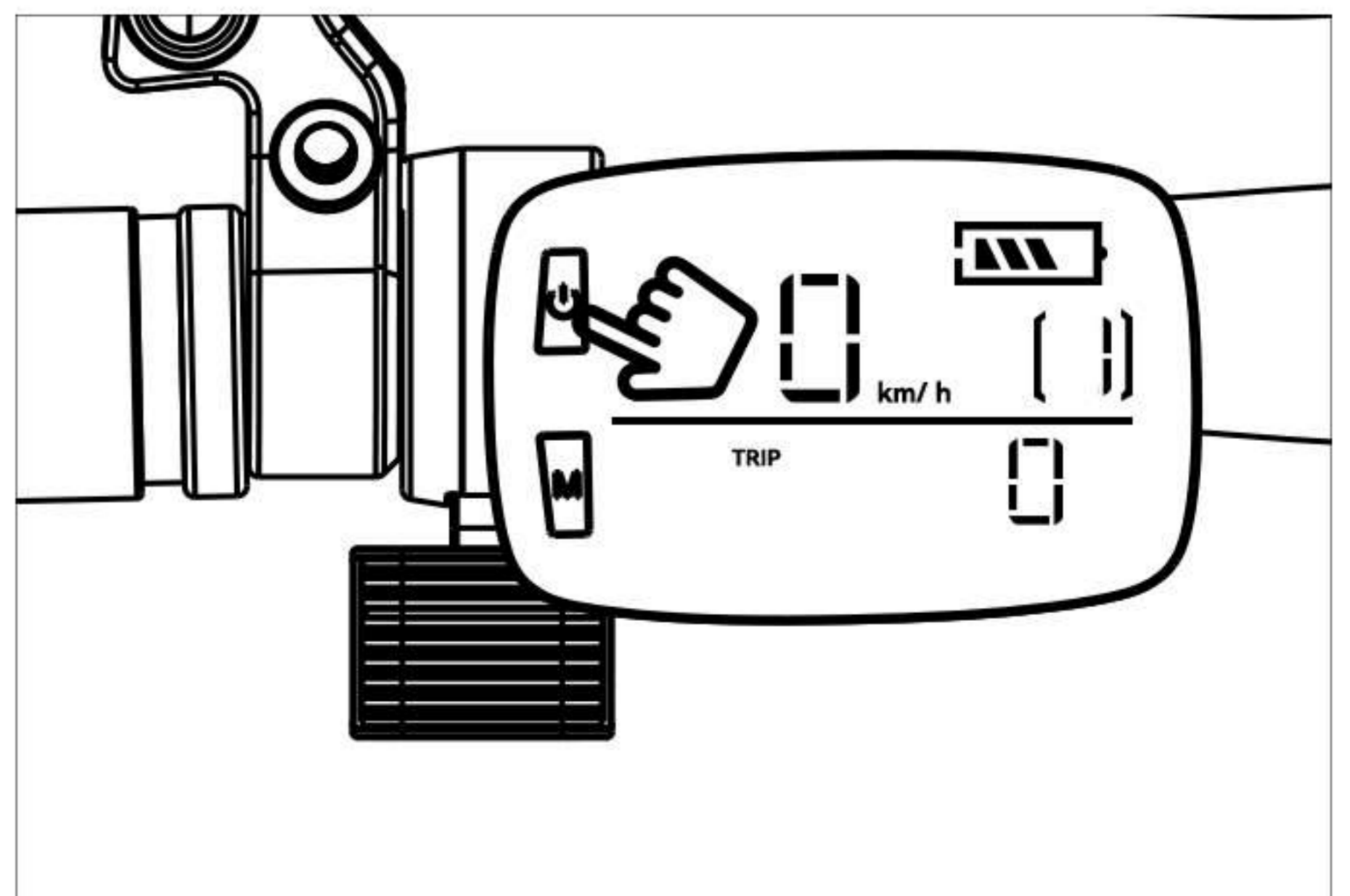

Turn Your Bike Off

1. Press and hold down the “POWER” button on the LED display to turn your bike on.
2. Then turn the battery key to the OFF position to power off the bike.

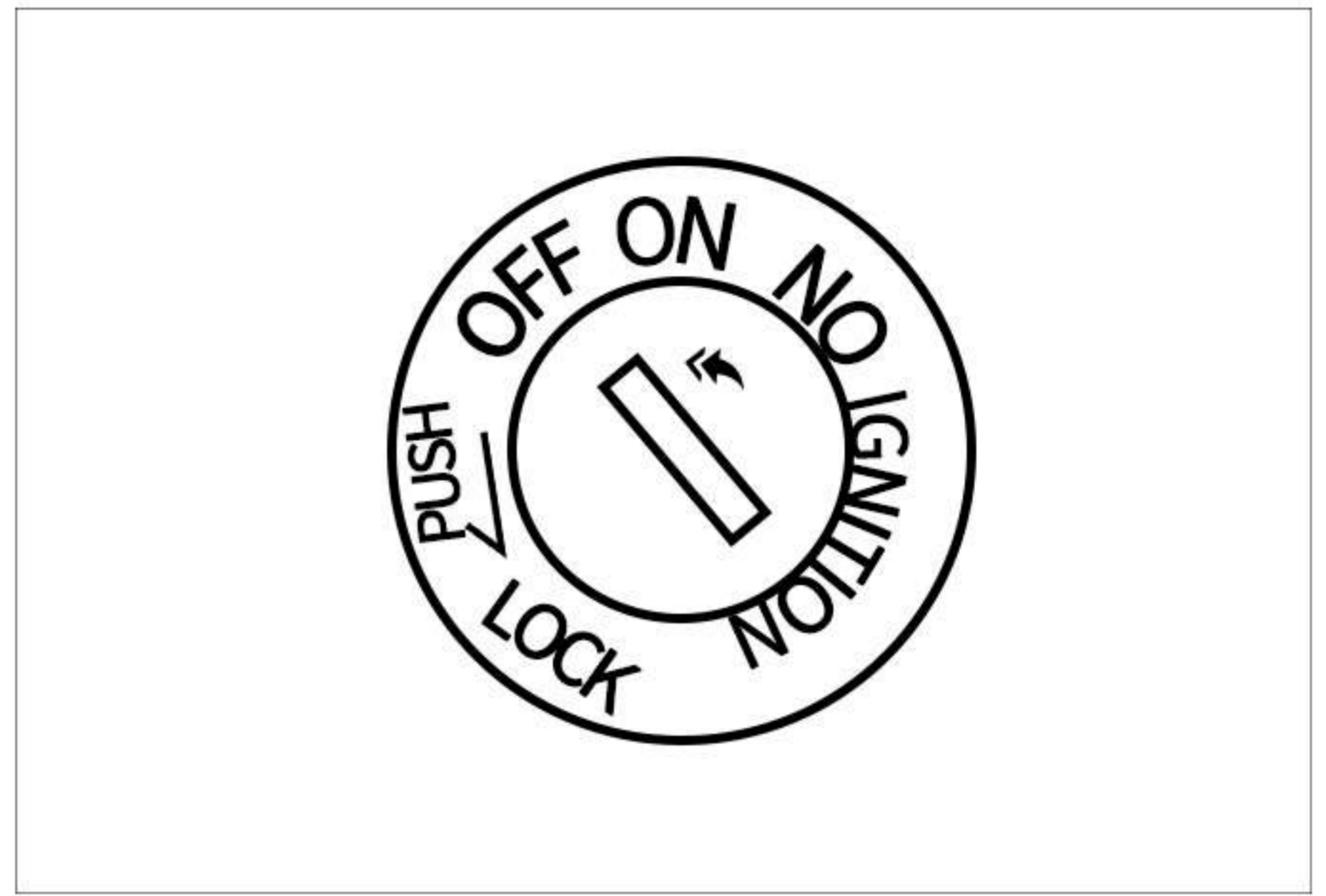
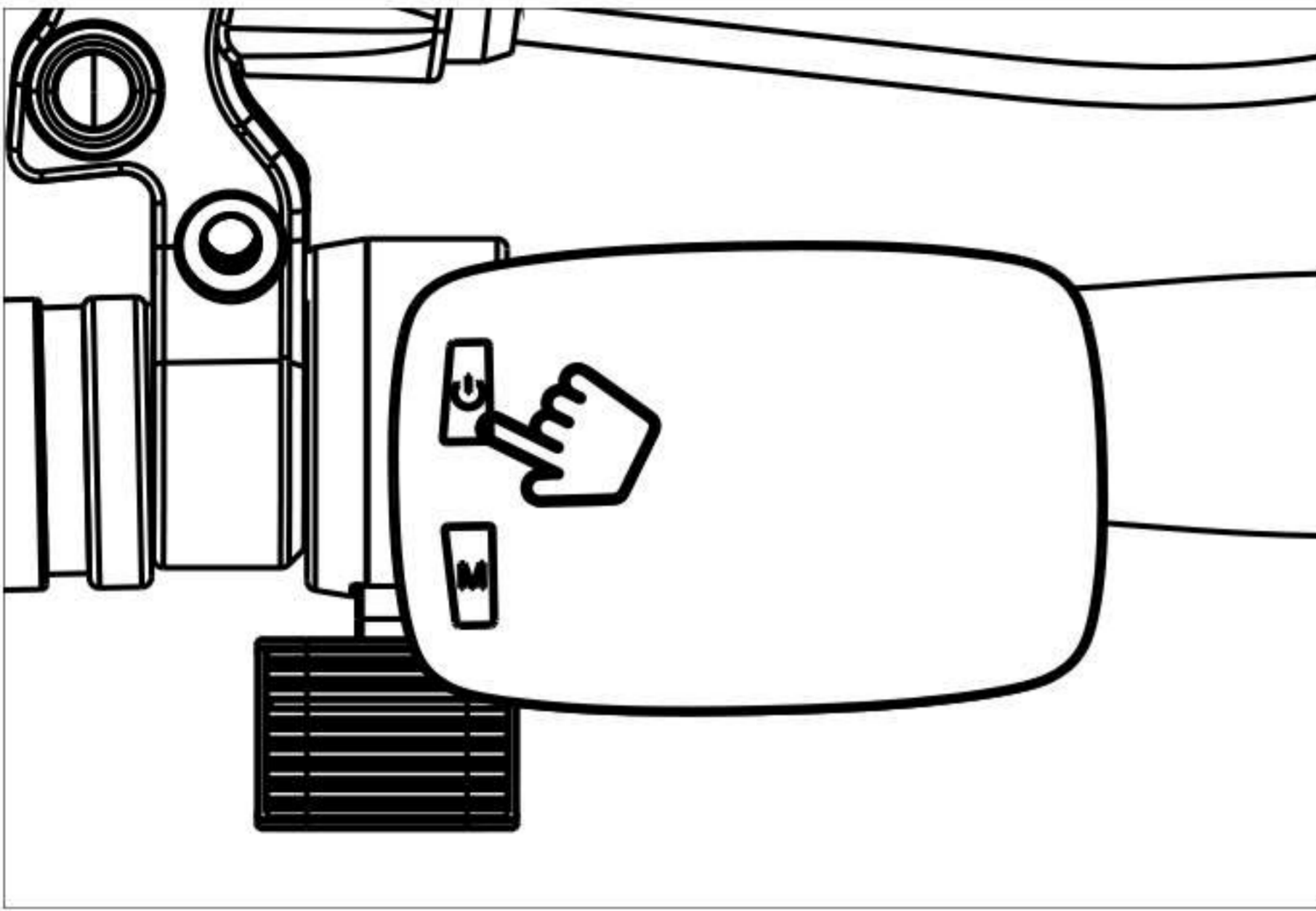

Note: That it is a normal phenomenon that the LCD display comes on and throws an "E" symbol when the battery key is turned to the "OFF" position.

INCREASE/DECREASE THE PAS LEVEL (PEDAL-ASSIST)

1. Tap the M (mode) button to toggle among the PAS levels.
2. By default, it shows Level 1 and there are six level options: Level 0, Level 1, Level 2, Level 3, level 4, and Level 5.
3. Level 0 indicates “without pedal assistance” .

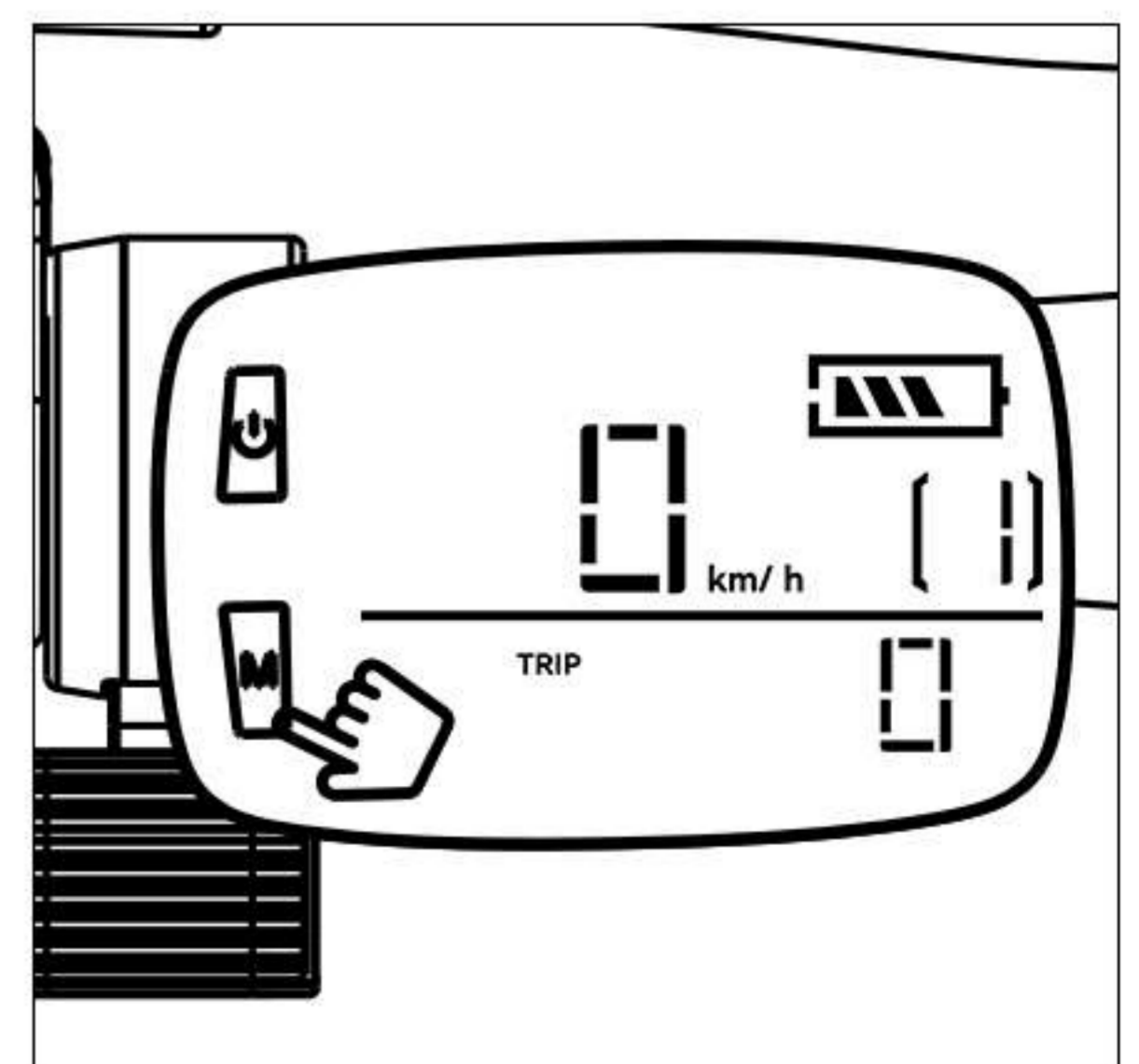
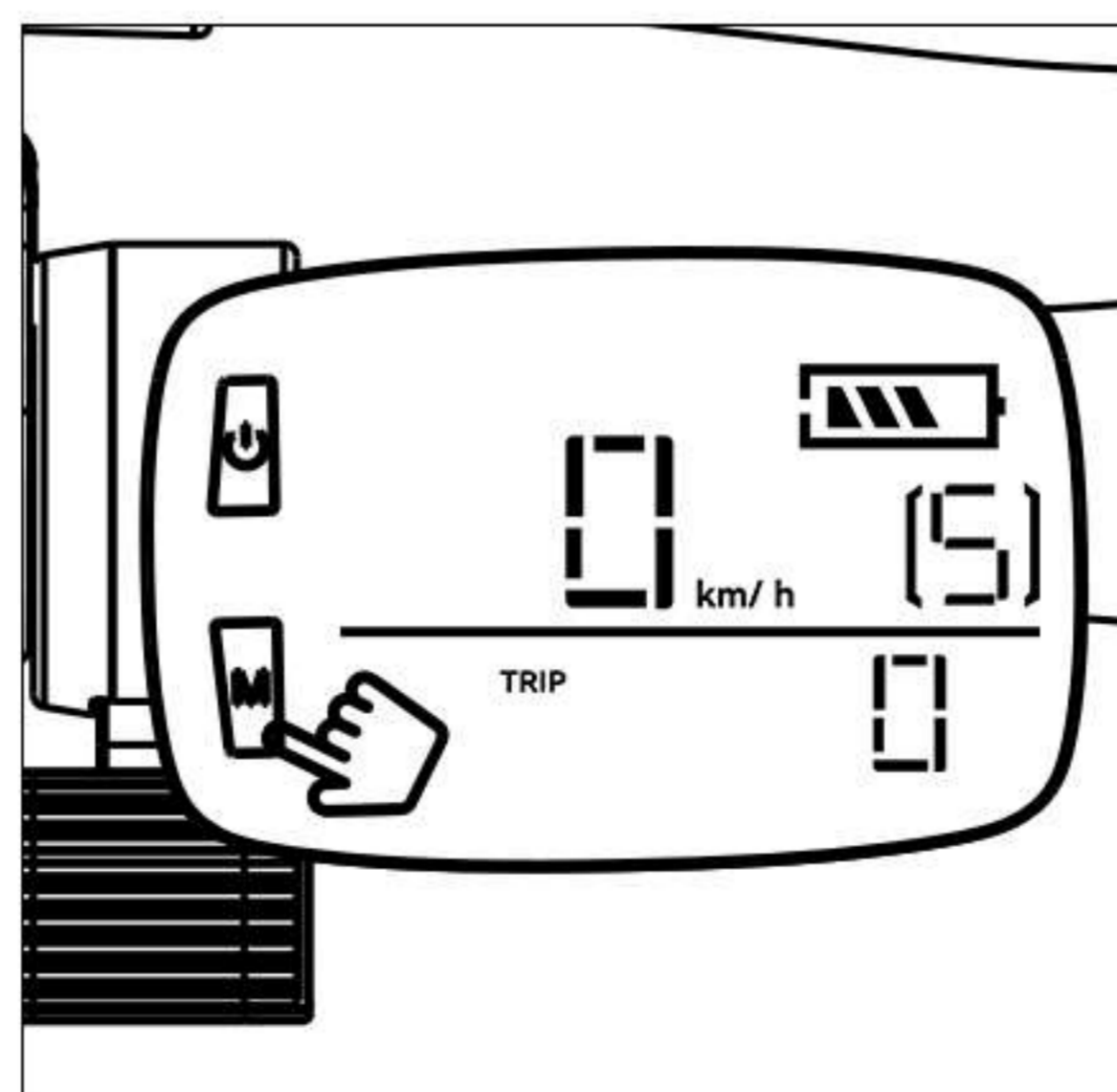
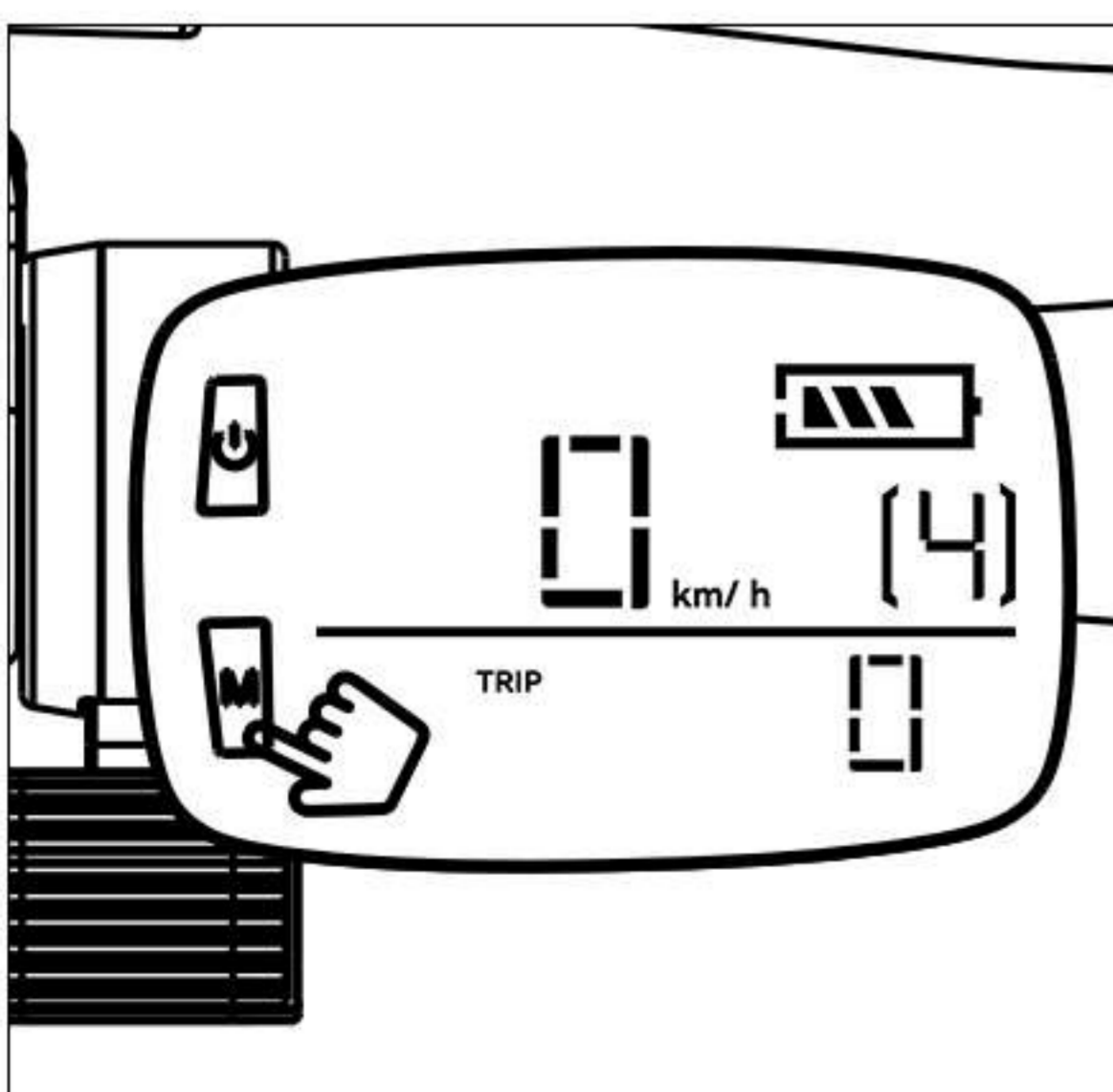
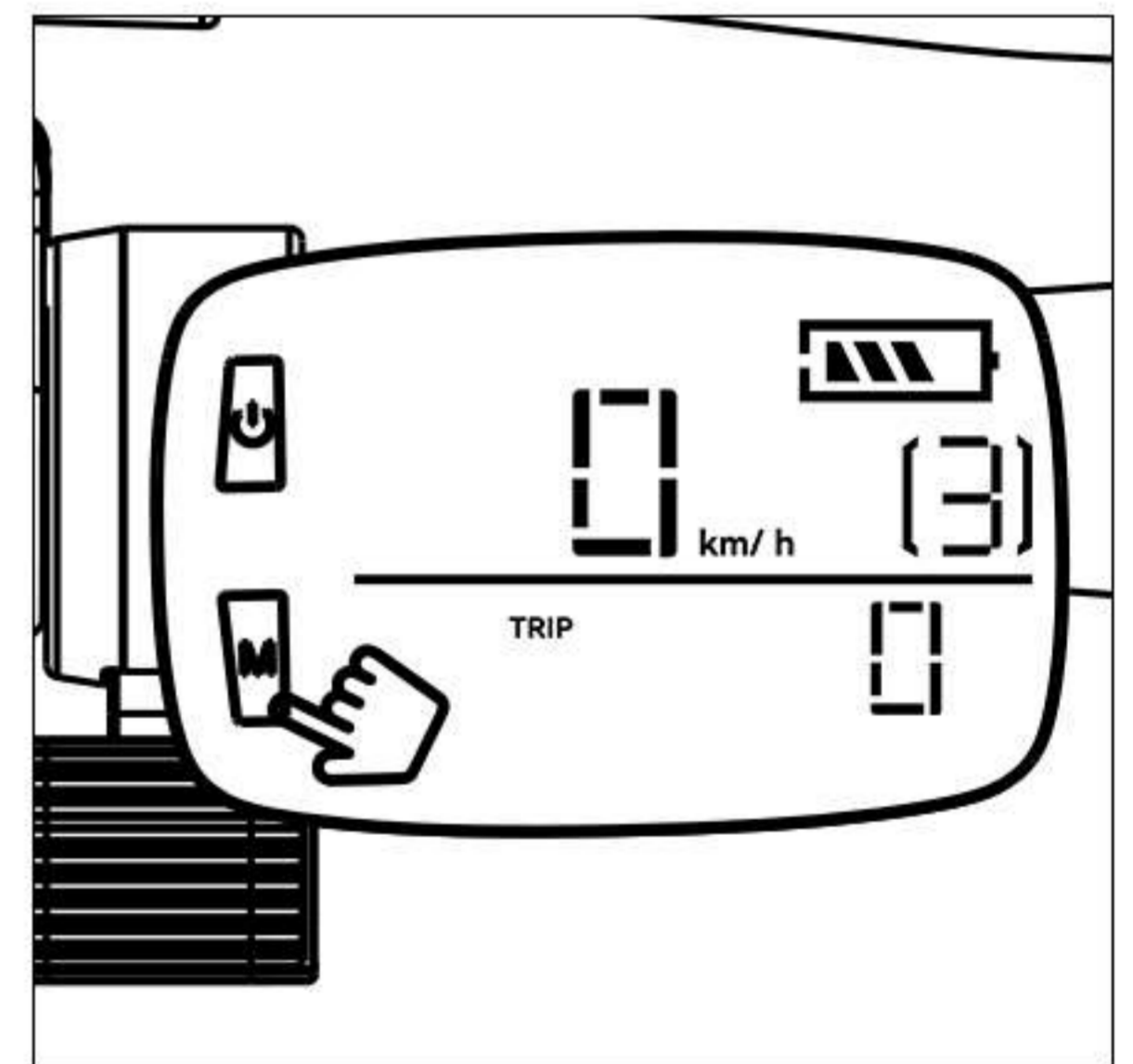
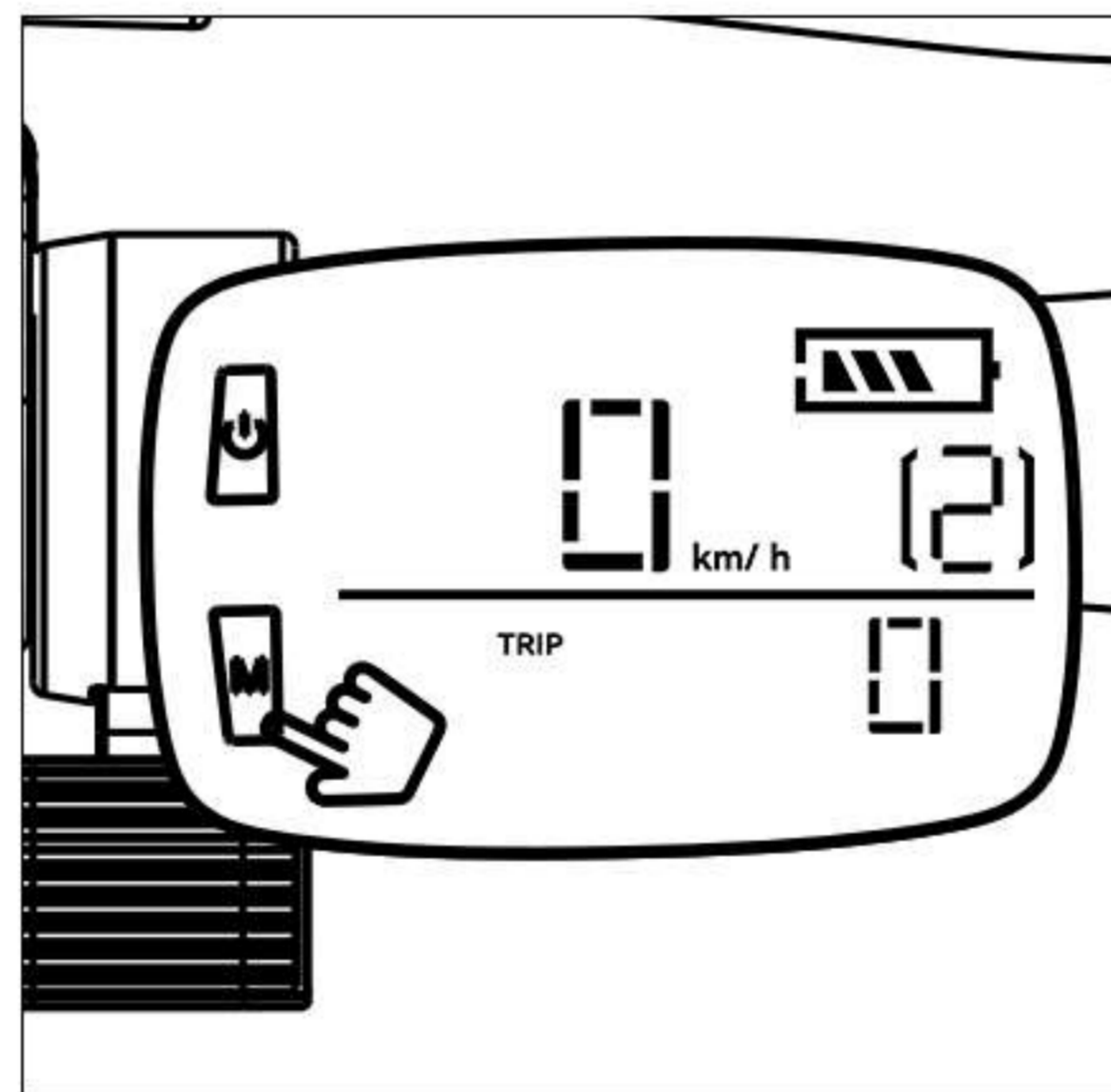
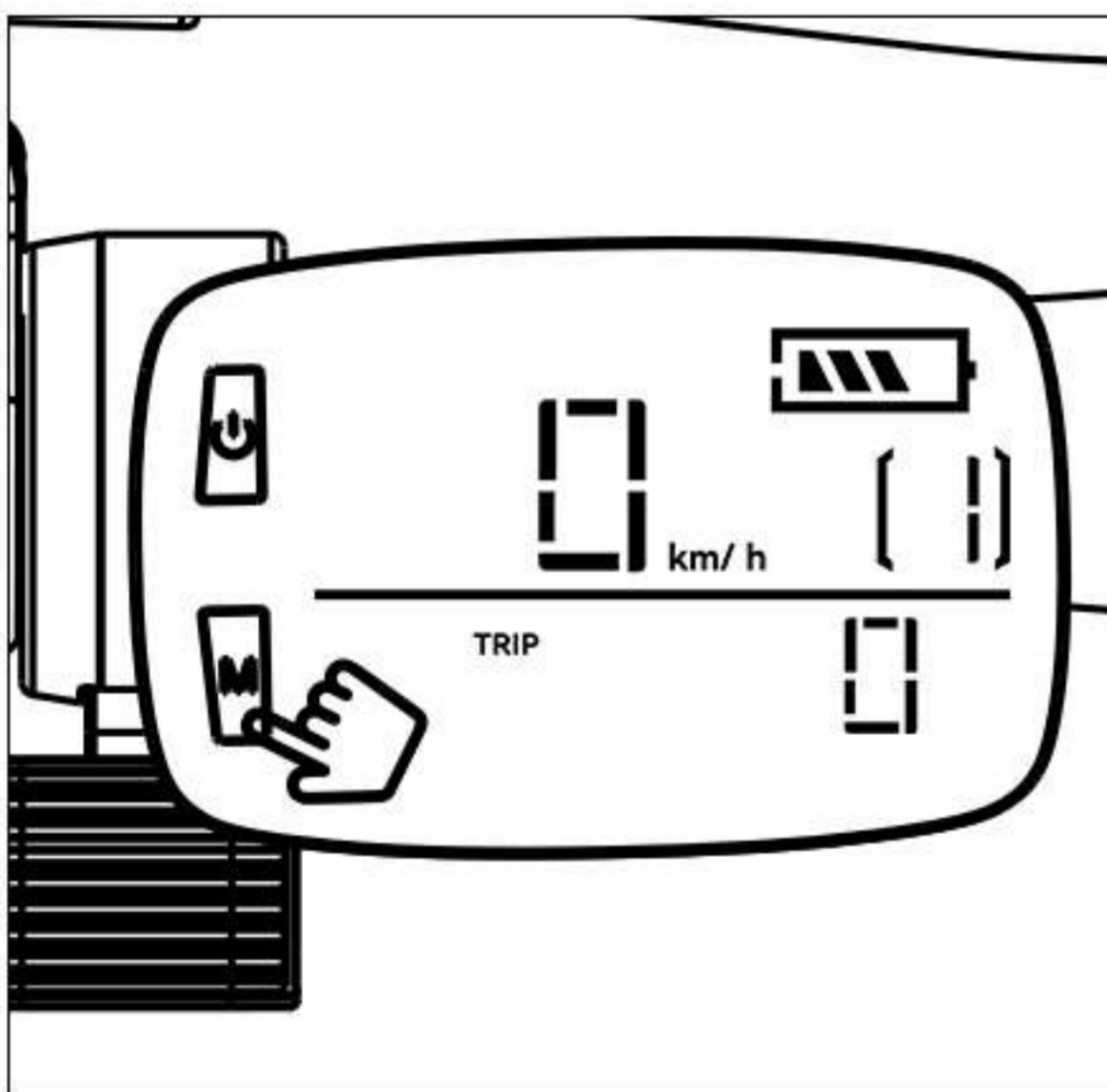

ADVANCED MENU [SPEED LIMITER]

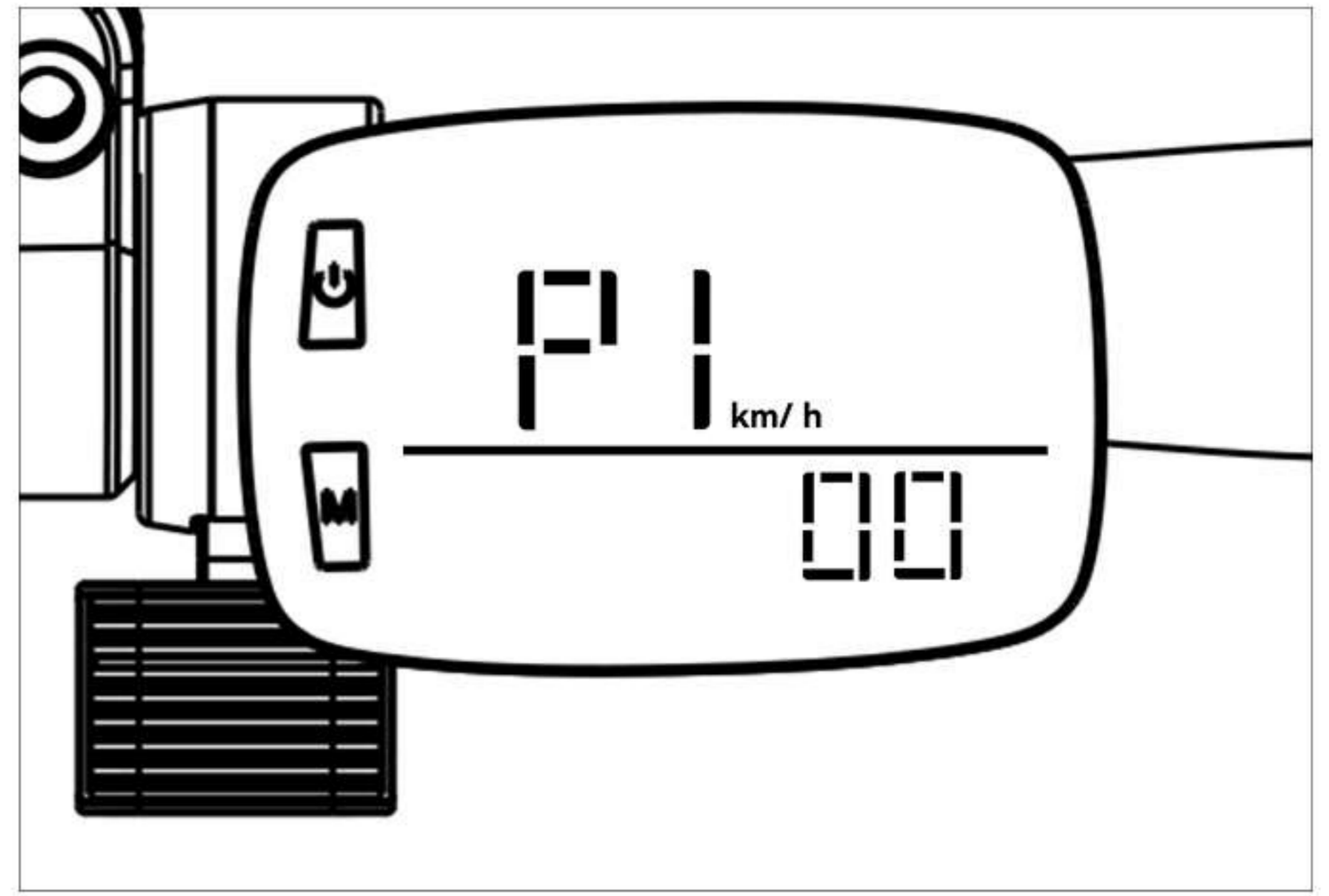
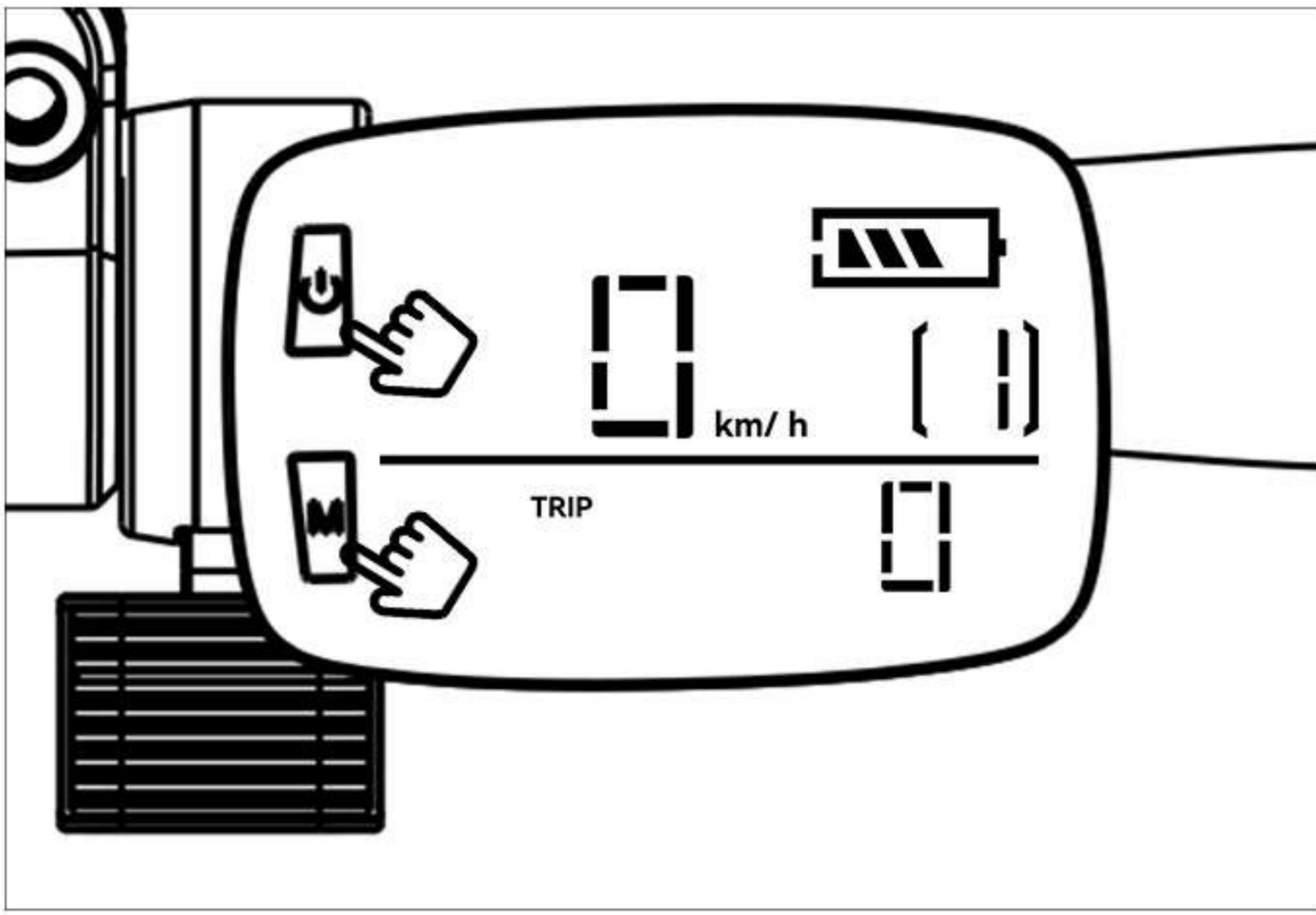

1. At the initial state, press and hold the POWER and M buttons at the same time to access the advance menu.

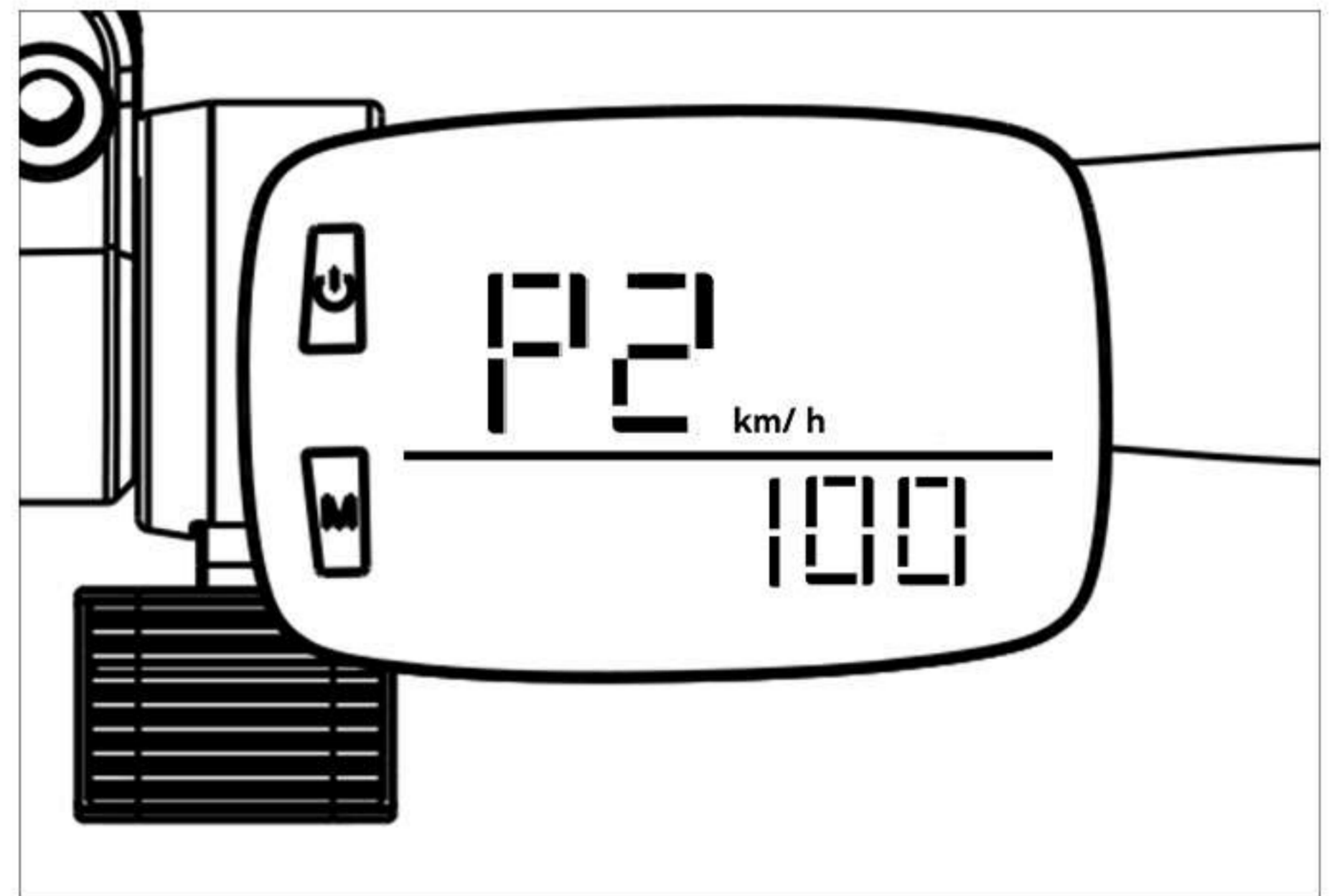
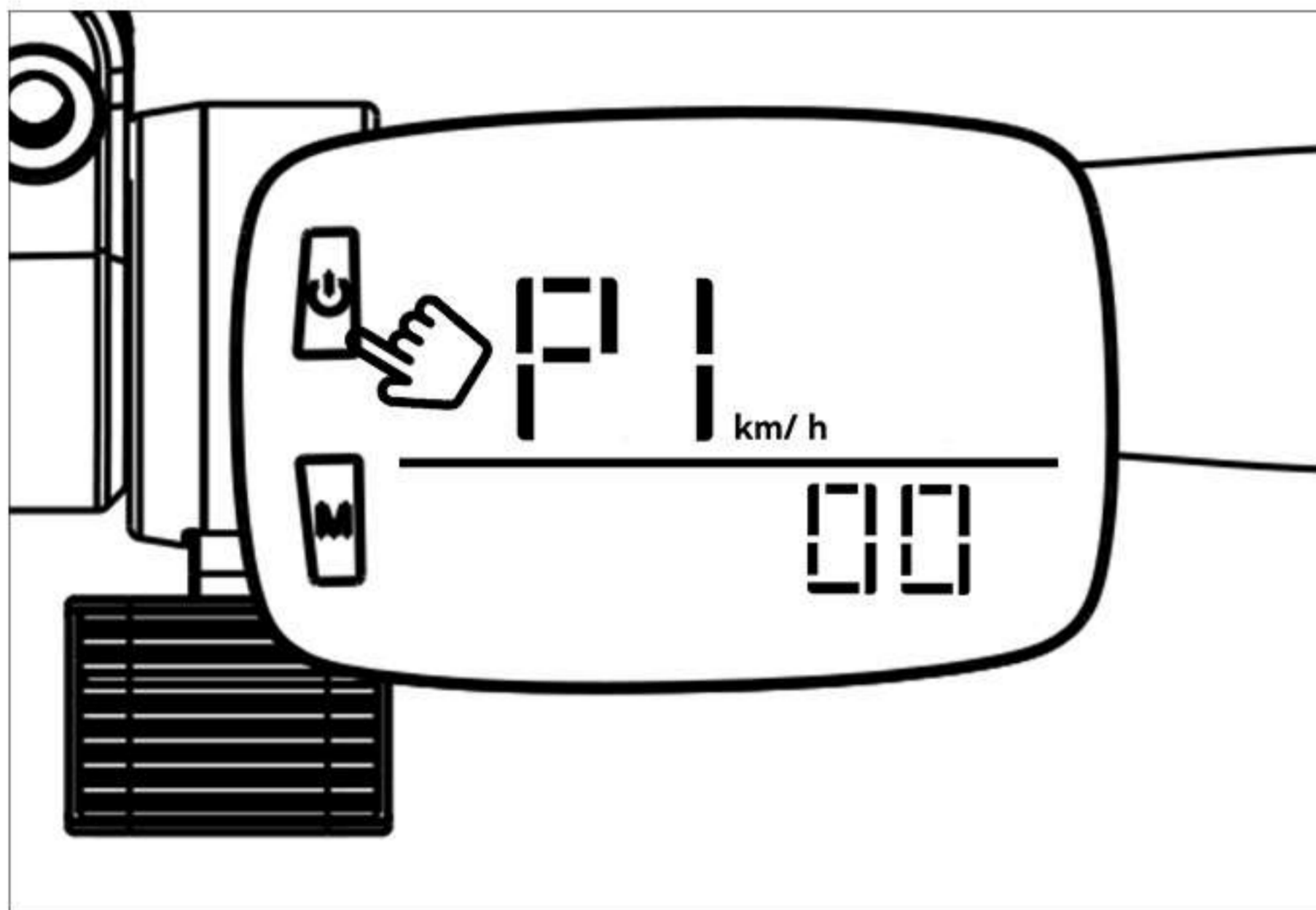

2. Press the POWER button to toggle between P1 (Imperial/Metric Mode), P2 (Speed Limiter).

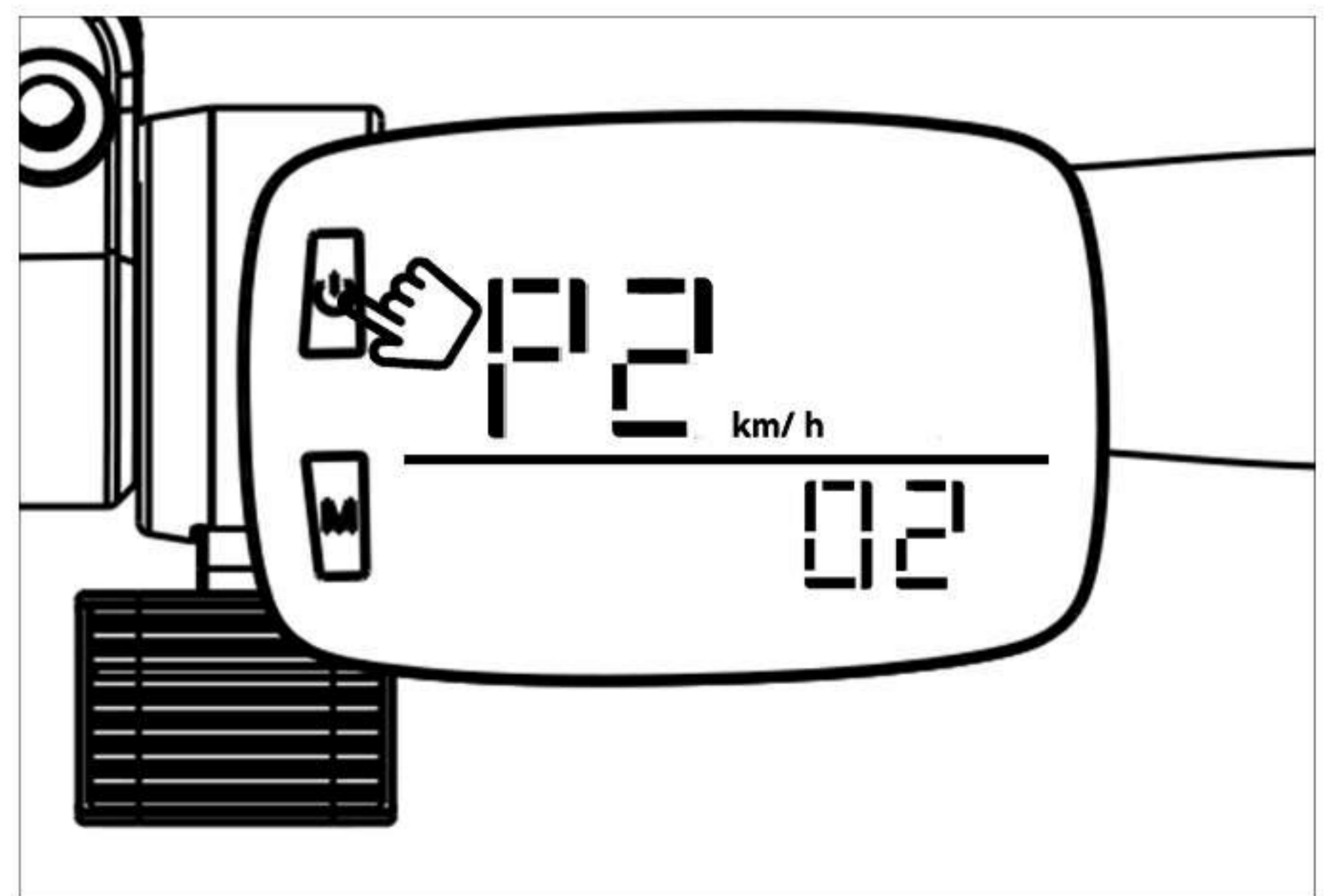
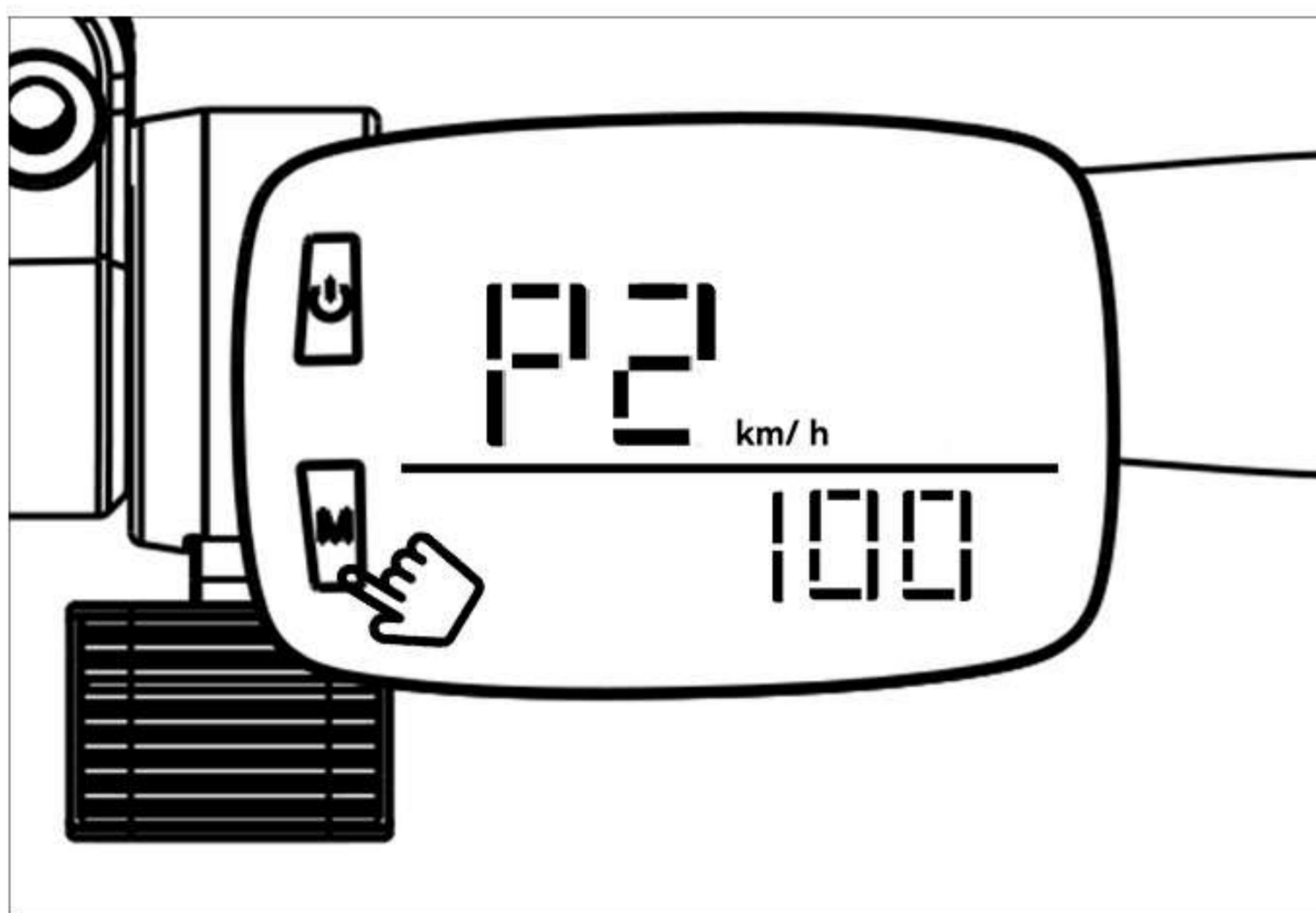

3. Press the M button to modify the selected option - P2 (Speed Limiter).

4. Tap the POWER button to change the parameters.

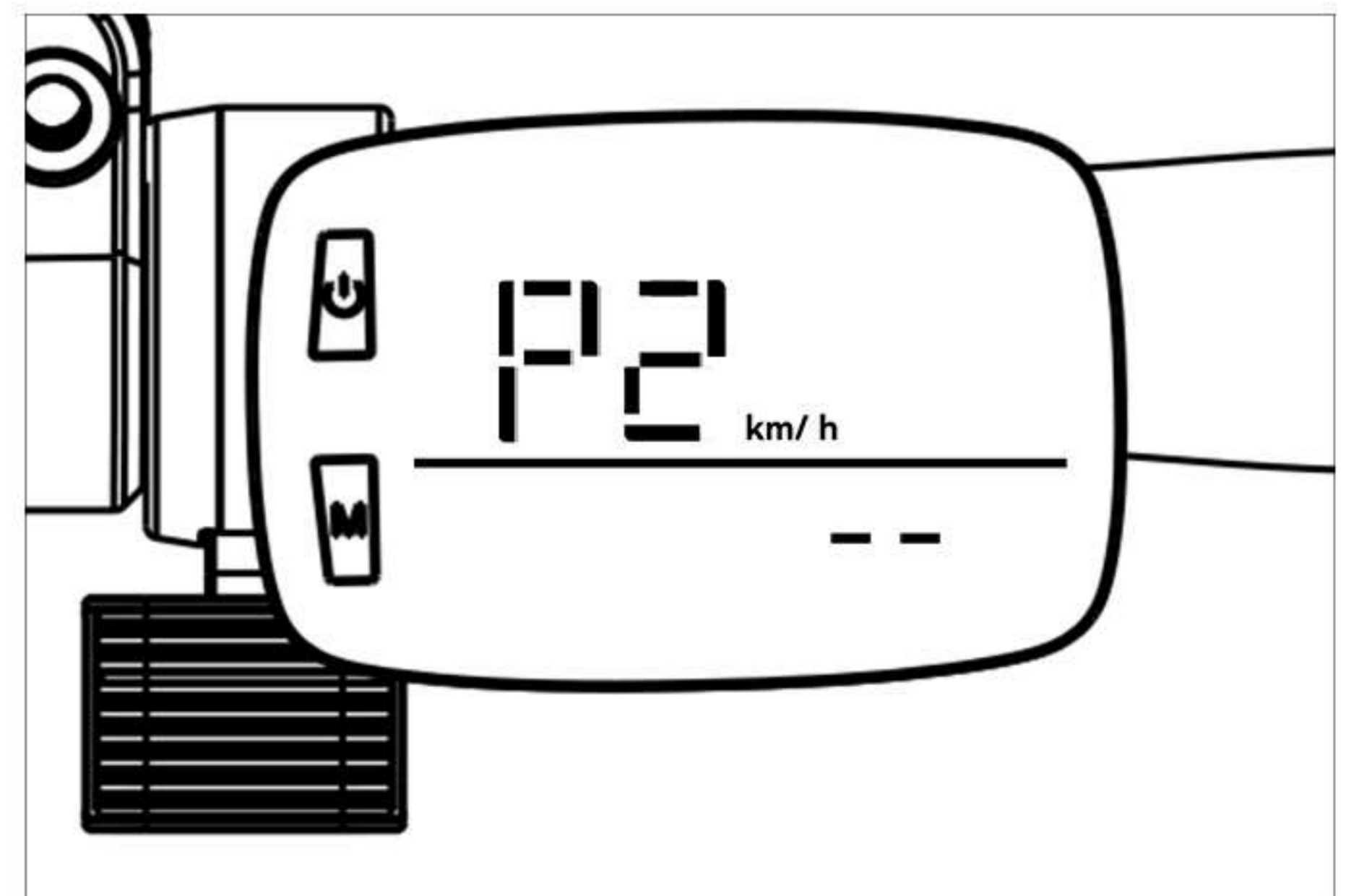
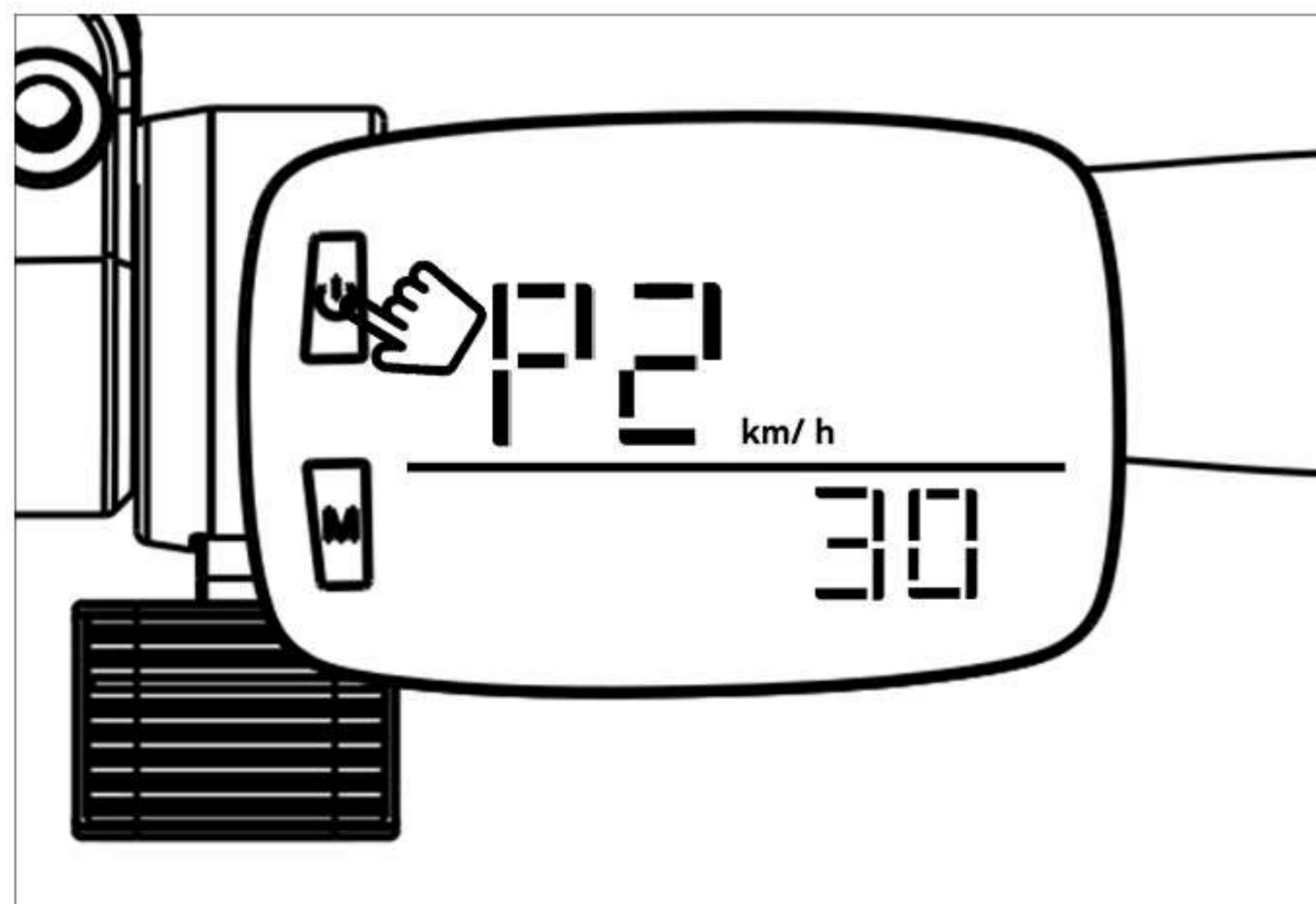

5. Press and hold the POWER button to save the settings.

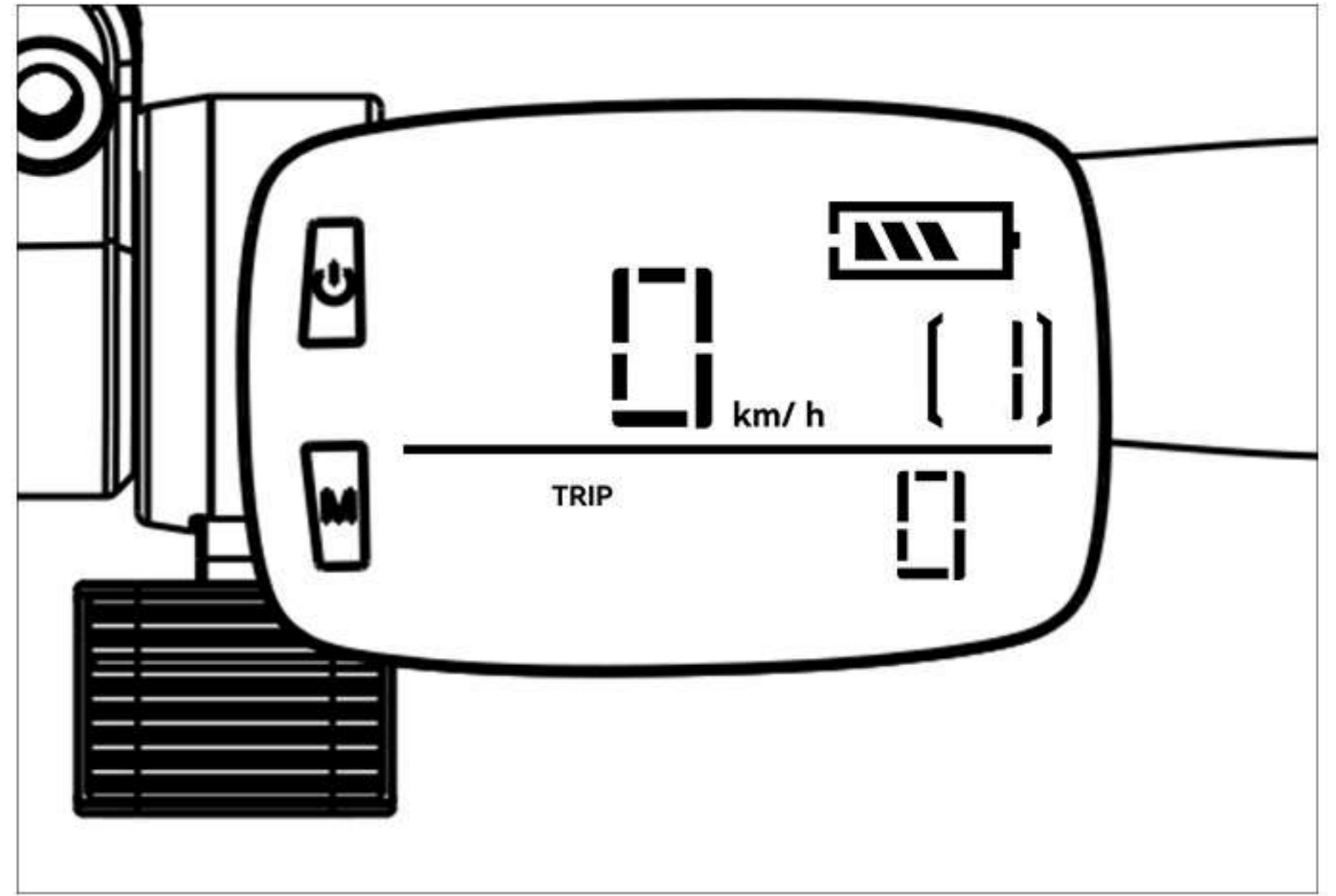
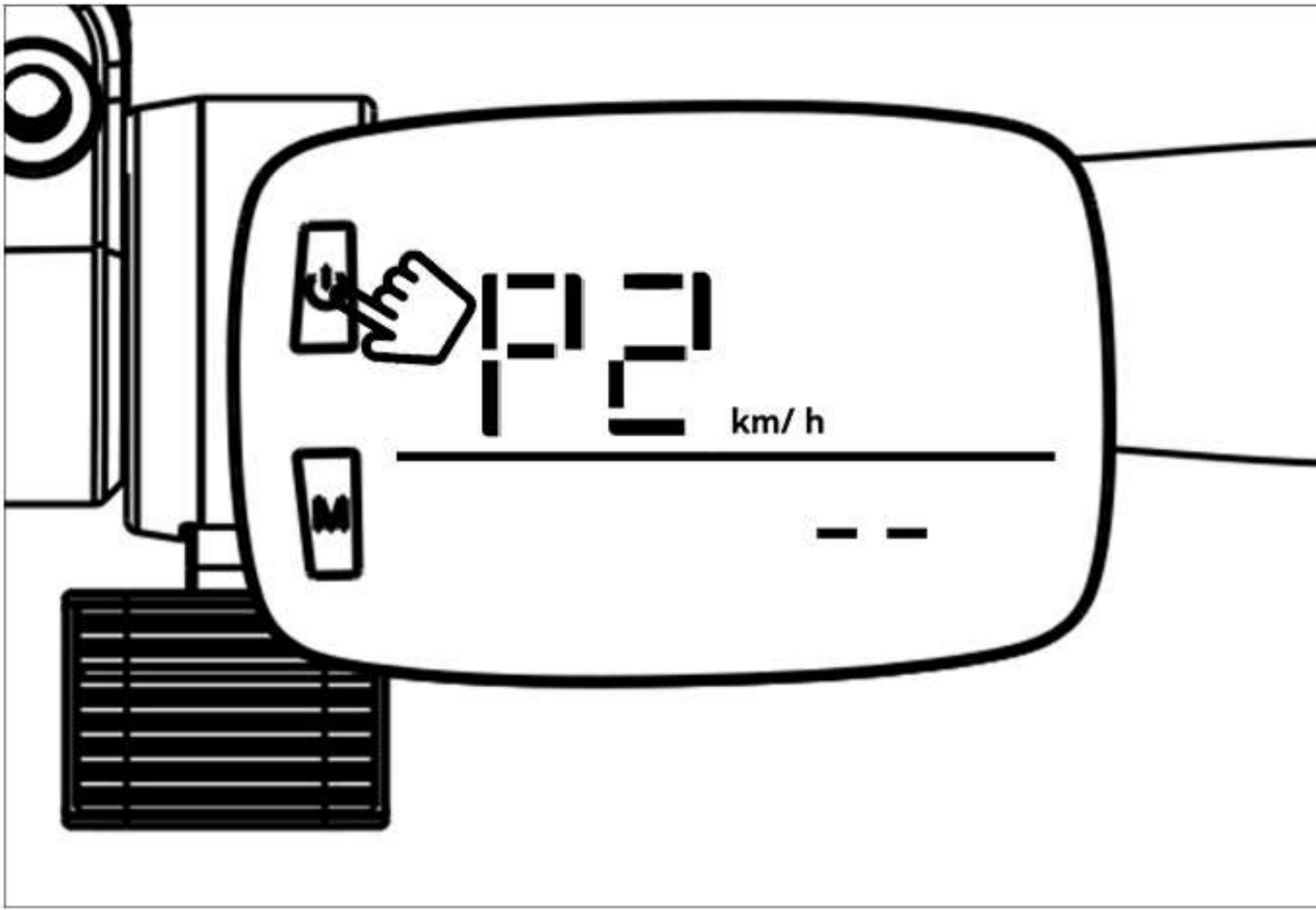

6. Press again to return to main screen.

OPTIONAL READOUT DISPLAY MENU

1. It shows trip meter by default. To toggle the display modes to odometer, press and hold the M button until it says "ODO"(odometer) on the screen.

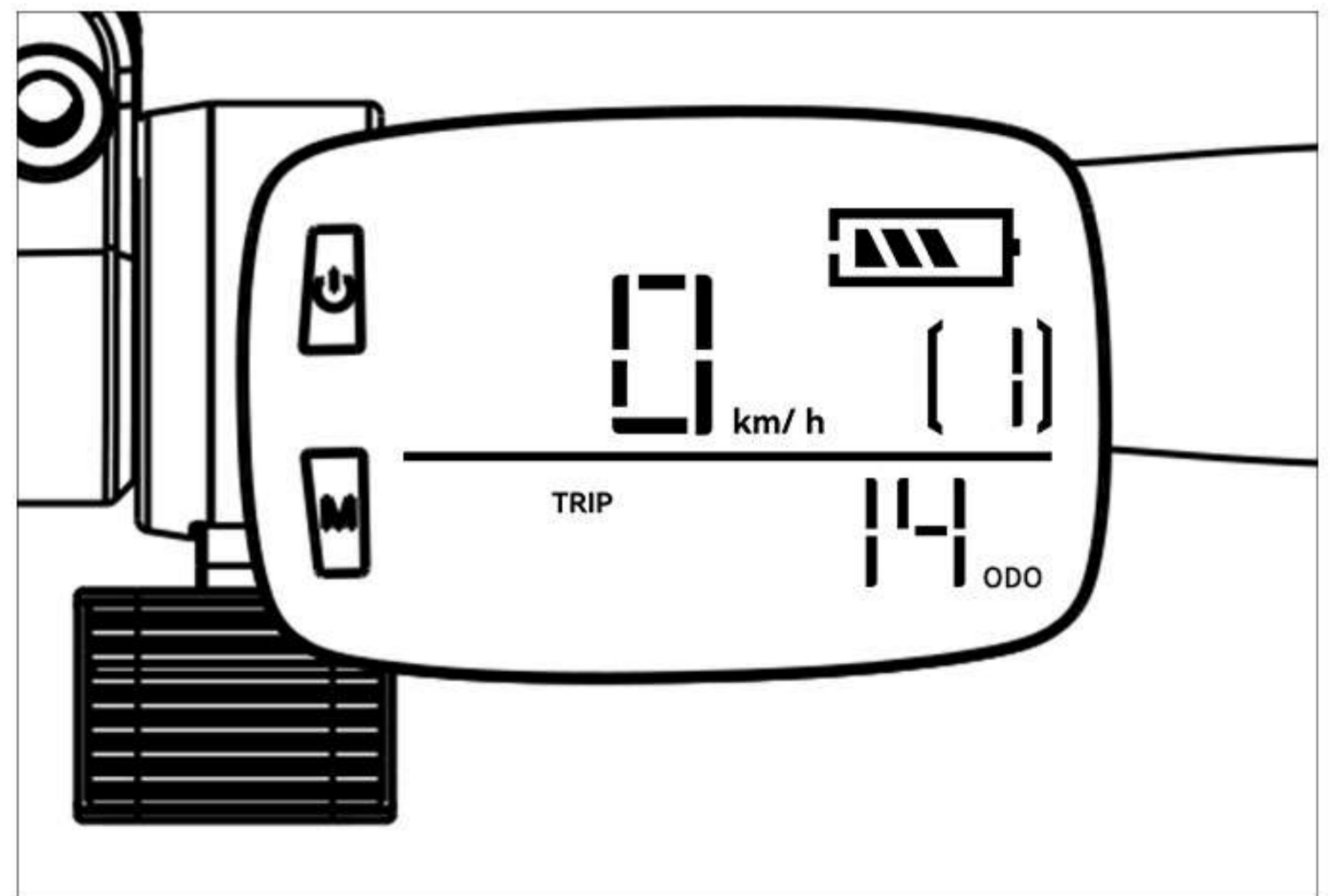
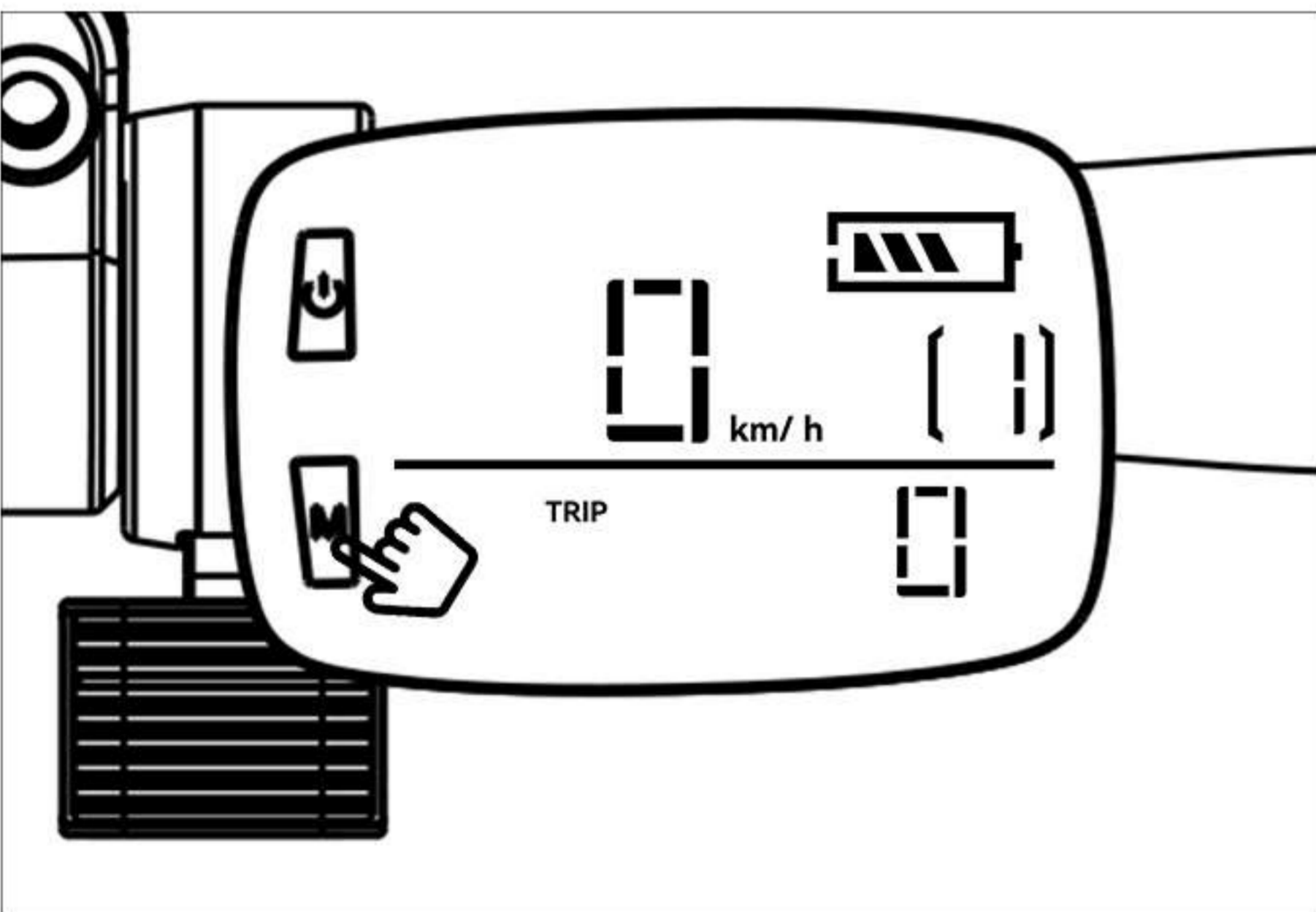

LIGHTING SYSTEM

1. Tap the POWER button to turn the headlight on / off.

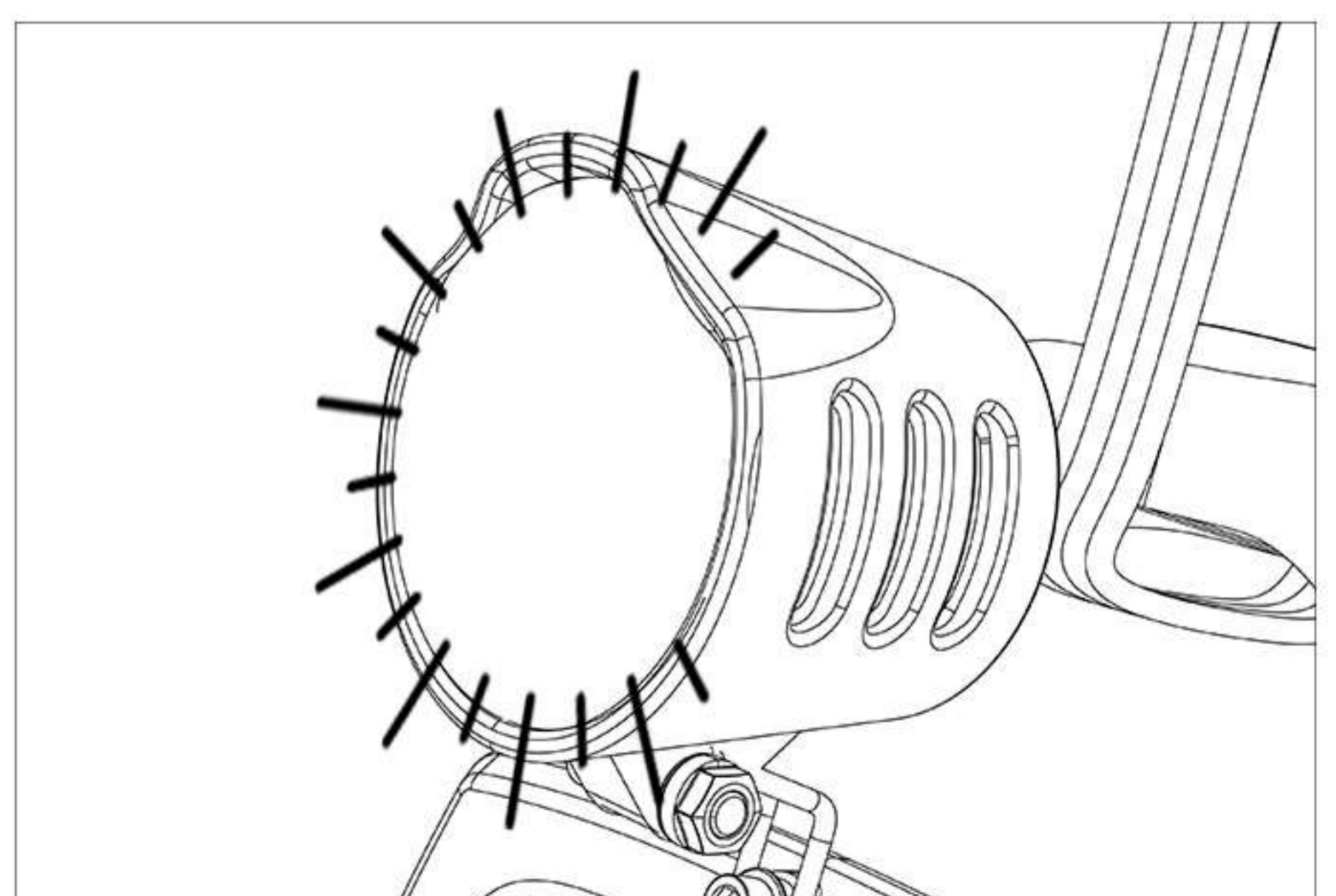
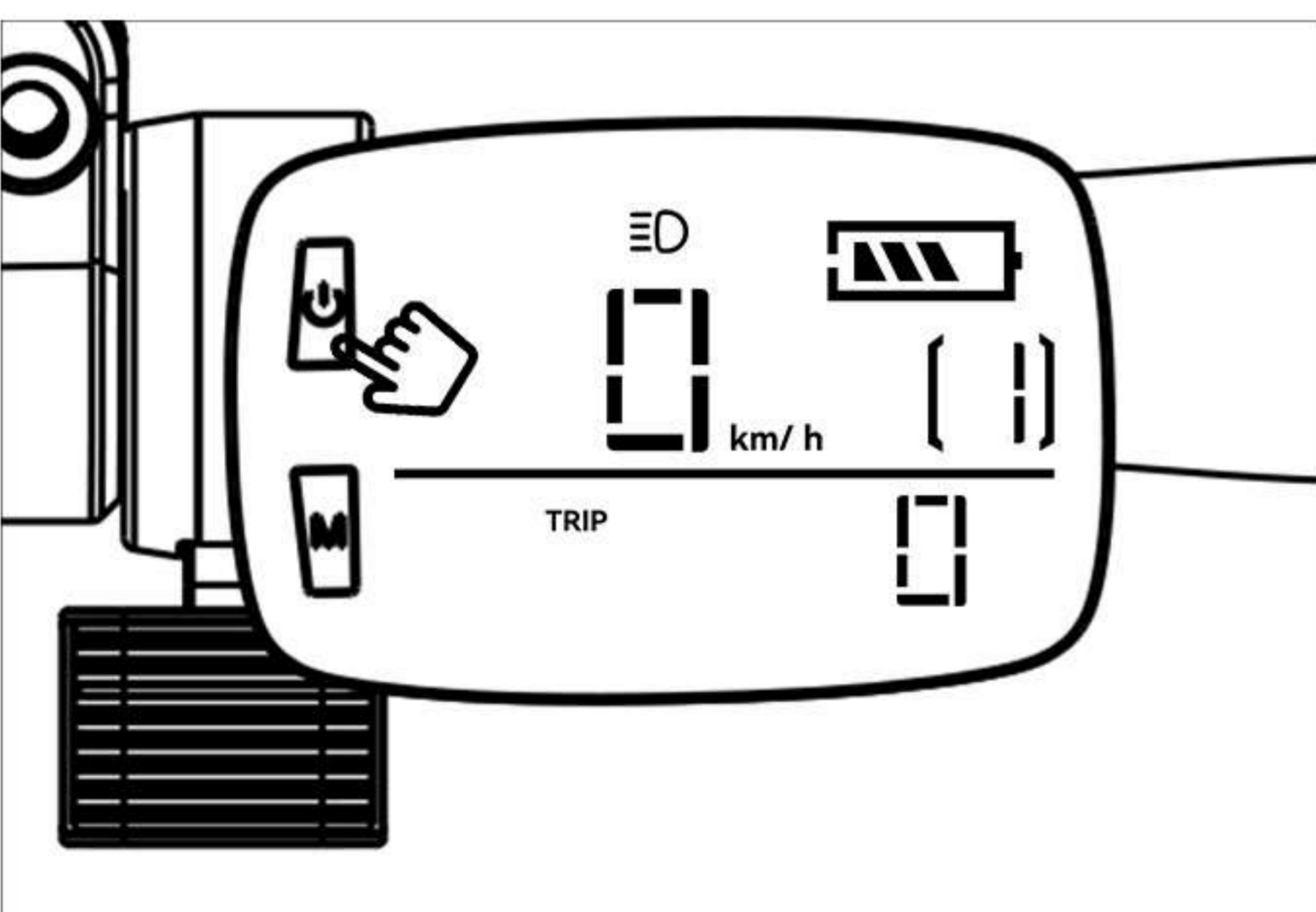

OPERATING SAFETY

Before riding the bike for the first time, ensure that you have read and understood this manual. Make sure you understand how to turn on and activate the pedal assist and throttle. When first riding the bike, take care to start slowly in a low level of pedal assist. Take your first ride in a safe area away from cars, other bikers, pedestrians, or other potentially dangerous obstacles. Only move up pedal assist levels when you feel comfortable and you have ample experience riding the bike. The higher pedal assist levels will accelerate you to higher speeds more quickly. Take care when riding the bike at any speed. Failure to adhere to warnings and guidelines in this manual can lead to serious harm, injury, or death. Damage sustained by the bike from failing to follow instructions, guidelines, and warnings in this manual is not covered under warranty. Do not lean on the bike when it is parked and the kickstand is in use.

Helmets and Local Laws

Always wear a helmet when riding your eBike. Ensure that the helmet fits your head and is securely tightened down. Before riding, read local laws and comply with all rules relating to cycling and eBiking in your area. If you attach a seat for children to the bike, they must also be wearing a properly fitted helmet at all times.

Pre-ride Safety Check and Inspection

Before each ride, make sure to inspect your eBike to ensure there are no loose fasteners or accessories. Make sure to specifically check that both the front and rear axles are secure. Also make sure both the handlebars and the handlebar stem are not loose. Check the tire pressure of both wheels before riding to ensure the tires are inflated to the recommended pressure printed on the side of the tire walls. Pull the brake levers to make sure your brakes are working properly and adjust if necessary. Ensure both your seatpost and handlebar stem are inserted past their minimum insertions points as indicated by the markings on them. Make

Riding in Wet Conditions

This electric bicycle can withstand light rain and small splashes, but is not designed to be subjected to inclement weather, extremely heavy showers, or submersion in water.

Note: Use caution when riding in wet conditions as it will take longer to use the brakes to slow down, and also when turning as the tires may slip. The electrical components on the bike are not waterproof. The entire bike has an IP rating of 65. Water damage is not covered under warranty.

Riding at Night

Riding at night comes with more risks than riding during the day due to decreased visibility so riders are encouraged to exercise increased caution. Before riding at night, make sure that reflectors are installed on your eBike. For increased visibility, also ensure the front headlight and rear tail light are turned on and adjusted such that other people on the road can see them clearly. Riders should wear bright colored clothing at

Max Weight

The bike can safely carry a total weight of 300 lbs. If the rear rack is attached to the bike, the max weight it can hold is 75 lbs. Therefore if you have a payload that is 40 lbs the maximum rider weight is 260lbs. Failure to adhere to these weight limits may invalidate your warranty, cause damage to the bike or rack, or cause serious injury to the rider. Note range and top speed will be affected by total weight being carried by the bike.

PRE-RIDE SAFETY CHECK

Ensure all components are properly secured before riding otherwise serious harm or death could occur. This includes but is not limited to: pedals, handlebars, handlebar clamp, cranks, seat, and seatpost clamp.

- Make sure you can't twist the seat or stem out of alignment by hand.
- Check to see if your saddle is positioned at the proper height. Sit on the saddle facing forward and place the ball of your foot on the pedal at its lowest point. Your leg should be mostly straight at this point with a slight bend at the knee. You should be able to pedal the bike without overextending your leg when the pedal is at its lowest point. Your legs may be overextended if it causes your hips to move side to side, which means the seat must be lowered. To start, adjust the saddle so your feet can still be placed firmly on the ground.

- To adjust your seat up or down, unlatch the seatpost clamp. Move the seat to the desired height and close the seatpost clamp. The open and closed positions of the seatpost clamp are shown below (open position on left, closed position on right). Handlebar Stem Seatpost
- Ensure both your seatpost and handlebar stem are inserted past their minimum insertion points as indicated by the markings on them. These markings are shown below. Failure to insert past the minimum insertion point will place undue stress on these components increasing the risk of sudden failure potentially resulting in harm, injury, or death.
- Check your seatpost clamp and handlebar stem quick releases torque. They should be tight enough so that they do not twist or fall down when the bike is in use. Unlatch the quick releases and tighten by turning the bolt clockwise. Make sure both quick releases are tightened to the torque listed in the Recommended Torque Values section of this manual. The page number of this section can be found by referring to the table of contents at the beginning of this manual.
- If you need to adjust the angle of your seat or the position of the seat on the rails, loosen the nuts on both sides of the seat, move the seat to the desired angle/position, then tighten the nuts. The nut's location is shown below.
- Ensure all cables and connectors at the front of the bike are securely connected or certain components may not work including the front light, the motor inhibitor switches, LCD display, and throttle. The motor inhibitor switches shut the motor off as soon as the rider hits the brakes. If these switches are not operational it will take longer to slow down which in some riding situations could cause injury or death to the rider. If you have installed any accessories make sure they do not interfere with all cables and connectors when turning the handlebars.

WARRANTY

All Bikes should be operated in accordance with the SOHAMO owner's manual provided with the bike. SOHAMO warrants to the original registered purchaser that bikes shall be free from all defects in material and workmanship for a period of 12 months from the date of shipment, when used in accordance with the owner's manual and for the purpose intended. All other obligations and conditions or liabilities, including obligations for consequential damages, are hereby excluded.

The warranty is nontransferrable and only applies to the original owner. This warranty gives you specific rights and purchasers may also have other rights, which may vary by location. Damage caused by failing to adhere to instructions and warnings issued by SOHAMO is not covered under warranty. Warranty parts will only be shipped within the continental United States. The warranty period of parts is as follows.

Warranty time is calculated from the sales date.

	Accessories	Three Packages	Three Guarantees Failure Type
Electrical parts	Motor	12 months	Free repair of failure within two years
	Controller	12 months	Performance failure
	lithium battery	12 months	Can't charge and discharge
	charger	12 months	Performance failure
	meter	12 months	Malfunction
	Turn handle	3 months	Malfunction
	Brake lever	3 months	No power-off function
	Booster	3 months	No induction capability
Structure	Frame	12 months	There are natural welding, desoldering, and fracture phenomena
	Front fork	12 months	
	Riser	12 months	
	handlebar	6 months	
	crank	6 months	

Accessories sold on sohamo.com are not covered under warranty (except in cases of shipping damages). Stolen bikes are not covered under warranty.

Necessary precautions must be taken to ensure the bike and battery are not exposed to severe weather conditions.

Exposure to very wet, hot, or cold conditions may void the warranty.

We will replace any parts deemed to have been damaged during shipping. Shipping damage must be reported to SOHAMO within 14 days of shipment arrival. This applies to all products including bikes and accessories. You will NOT be refunded as compensation for your time or efforts replacing damaged parts. Replacement parts will not be sent until photographic evidence has been provided to SOHAMO. SOHAMO may request additional documentation (such as video) to assist with accurately diagnosing the problem and processing the warranty claim. Most warranty parts are fulfilled 1-10 business days after the request is put into our system by a customer service representative. Warranty parts are sent using USPS First Class, FedEx Express, or FedEx Ground depending on the size of the part. Warranty parts will not be expedited. Items including the chain, tires, wheels, tubes, battery handle, brake pads, cables and housing, grips, and spokes are considered wear items.

These items wear down with normal use and are not covered under warranty. You are responsible for replacing and maintaining these wear items. Any unauthorized alterations or repairs are not covered and may void this warranty. For warranty services, please contact SOHAMO online support by email at support@sohamo.com. Bikes or parts returned without proper documentation may result in delayed service or denied warranty coverage. Warranty return shipping costs along with duties and taxes are the responsibility of the claimant.

ELECTRIC BIKE MAINTENANCE

Regular cleaning

Cleaning the bike often will help to keep dirt, dust, and debris from getting into the engine and messing with the motor. It also helps to keep all the mechanical parts moving properly without grinding against each other or blocking the chain. E-bikes should be washed once or twice per week.

When you clean your e-bike, do not use a pressurized hose or stream of water. This might compromise the integrity of the seals around electrical equipment and wear them down, eventually leading to exposed and wet electrical systems that will then malfunction. Instead, use a low-pressure water stream or a wet rag and dry the bike off once you're done washing it.

Lubrication

In order to keep all the mechanics in working order, you can apply lubrication on the major moving parts such as the chain. You should use a special cleaning solution to clean off the chain before applying a bike lubricant to it. This should ideally be done at least once a week if you use the bike often.

Check the bolts

Do a quick once-over and check for any loose screws, bolts, nuts, or anything else on the bike. If there is too much play in the bolts, tighten them up a little bit and see if you can identify the cause of the looseness. Don't tighten the bolts too far.

Tire pressure

You can check to see what the current pressure is in the tires by using a simple pressure gauge. If it's too low, or if the tires can visibly sink when you push your finger into them, you should get out your bike pump and inflate them properly to the pressure indicated on the tires.

Brake pads

Take a good look at the brake pads on your bike every few weeks to see how they are holding up. It's essential that you have effective brakes or else you could end up in a serious accident. Brake pads can easily and cheaply be replaced whenever necessary.

Waterproofing

The battery and motor of an e-bike are well sealed to prevent any water damage. That doesn't mean it's absolutely impossible for water to get in, but with a certain level of common sense and care, you won't need to worry. Things to avoid with an electric bike include using a jet wash and fully submerging the bike. No lake jumps then, sorry! The motor itself is in a factory-sealed unit and you should never attempt to take it apart for maintenance or to try and fix a problem.

Battery care

Charge the battery at room temperature in a dry location. To improve the lifespan of your battery, avoid leaving the battery fully charged or fully discharged for long periods of time. When the bike is out of use for an extended period, you can disconnect the battery. It will gradually lose charge, so still top it up every now and again. As we've already said, avoid storing the bike for long periods of time with no charge – maintaining 30 to 60 per cent charge is ideal for long-term storage, according to ebike systems manufacturer Bosch. Extreme heat and cold are the enemies of electric bike batteries. Store your ebike battery in a cool, dry place out of direct sunlight. During winter, and particularly if the temperature is below 0°C, charge and store the battery at room temperature, and re-insert the battery into the bike immediately before riding.

DISCLAIMER

Riding any kind of bicycle comes with inherent risks and dangers that cannot be predicted or avoided. These dangers could result in a serious accident, injury, or death of the rider. It is the sole responsibility of the rider to become properly educated and prepared to ride safely. Once in possession of the bike, SOHAMO strongly encourages and recommends that all customers have a certified and reputable bicycle mechanic complete a full inspection of each component on the bicycle to ensure it is safe for operation. SOHAMO makes no claims or guarantees that the brakes, battery, frame, motor, motor controller, LCD display, electrical cables, electrical cable housings, fasteners, grips, fork, stem, shifters, headset, seatpost, seatpost clamp, handlebar stem clamp, saddle, wheel hubs, handlebars, spokes, rims, tires, tubes, derailleur, freewheel, cassette, throttle, kickstand, lights, reflectors, hardware, bottom bracket, or any other part or accessory, will be properly secured and adjusted upon arrival. Before every ride fully inspect your bicycle to ensure everything is secured and adjusted properly. Under no circumstances is SOHAMO responsible for any damage resulting from damaged, defective, or improperly secured parts. This includes, but is not limited to, damage to personal property, personal injury, or death.